

MX.COM, INC. Mixed Signal ICs

DATA BULLETIN

CMX631A Low Voltage SPM Detector

ADVANCE INFORMATION

Features

- Detects 12 or 16kHz SPM Frequencies
- Tone Follower and Packet Mode Outputs
- High Speech-Band Rejection Properties
- Low Power Operation (3.0V < 1.0mA)

Applications

- Call Charge Applications on PABX Line Cards
- Complex and/or Simple telephone Systems
- Remote Telephone Applications

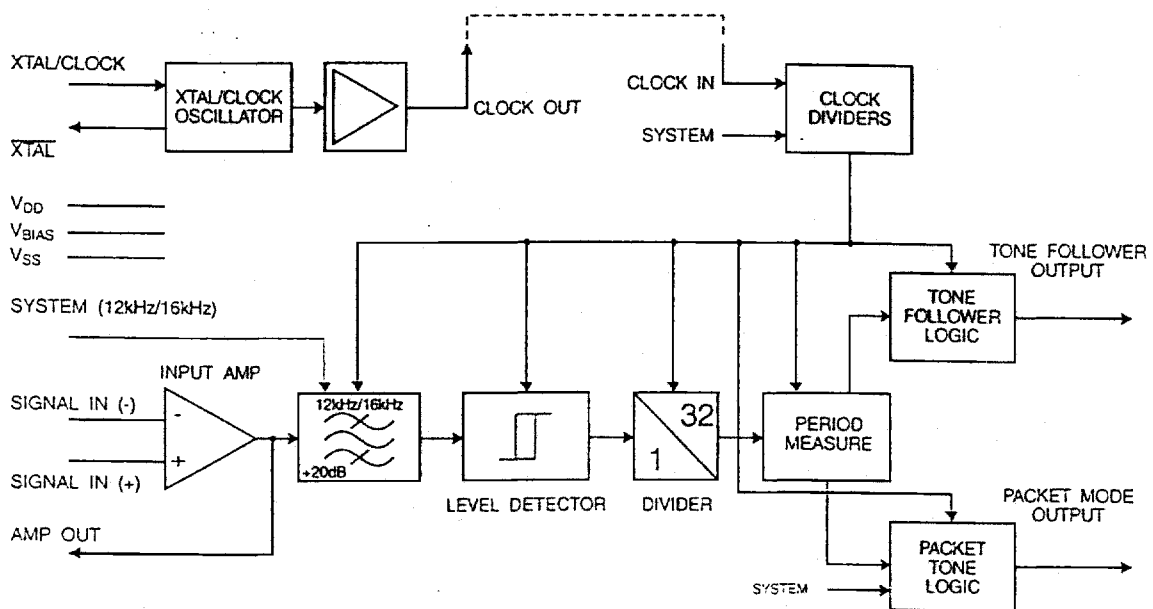

The MX631 is a low-power, system-selectable Subscriber Pulse Metering (SPM) detector that indicates the presence of both 12kHz or 16kHz telephone call-charge frequencies on a telephone line.

Deriving its input directly from the telephone line, input amplitude/sensitivities are component adjustable to the user's national 'Must/Must-Not Decode' specifications via an on-chip input amplifier. The 12kHz and 16kHz frequency limits are accurately defined by the use of an external 3.579545MHz telephone-system Xtal or clock-pulse input.

The MX631 demonstrates exceptional 12kHz and 16kHz performance in the presence of both voice and noise. This device may operate from either a single or differential analog signal input, from which two individual logic outputs will be produced; a Tone Follower Output or a Packet Mode Output.

This system (12kHz/16kHz) selectable integrated circuit, requires a 3.0V to 5.0V power supply, which may be line-powered is available in the following packages: 24-pin TSSOP (CMX631AE2), 24-pin SSOP (CMX631AD5), 16-pin SOIC (CMX631AD4), and 16-pin PDIP (CMX631AP3).

MXCT500003

CONTENTS

Section	Page
1. Block Diagram	3
2. Signal List	4
3. External Components	5
4. General Description	6
4.1 Tone Follower Mode	6
4.2 Packet Mode	6
4.3 Sensitivity Setting	6
4.3.1 Input Gain Calculation	6
4.3.2 Input Gain Components	8
4.4 'Must'/'Must Not' Decode Frequencies	8
5. Applications	8
5.1 Input Configurations	8
5.1.1 Protection Against High Voltages	8
5.1.2 Aliasing	9
6. Performance Specification	9
6.1 Electrical Specifications	9
6.1.1 Absolute Maximum Ratings	9
6.1.2 Operating Limits	9
6.1.3 Operating Characteristics	10
6.2 Packages	11

MX•COM, Inc. reserves the right to change specifications at any time and without notice.

1. Block Diagram

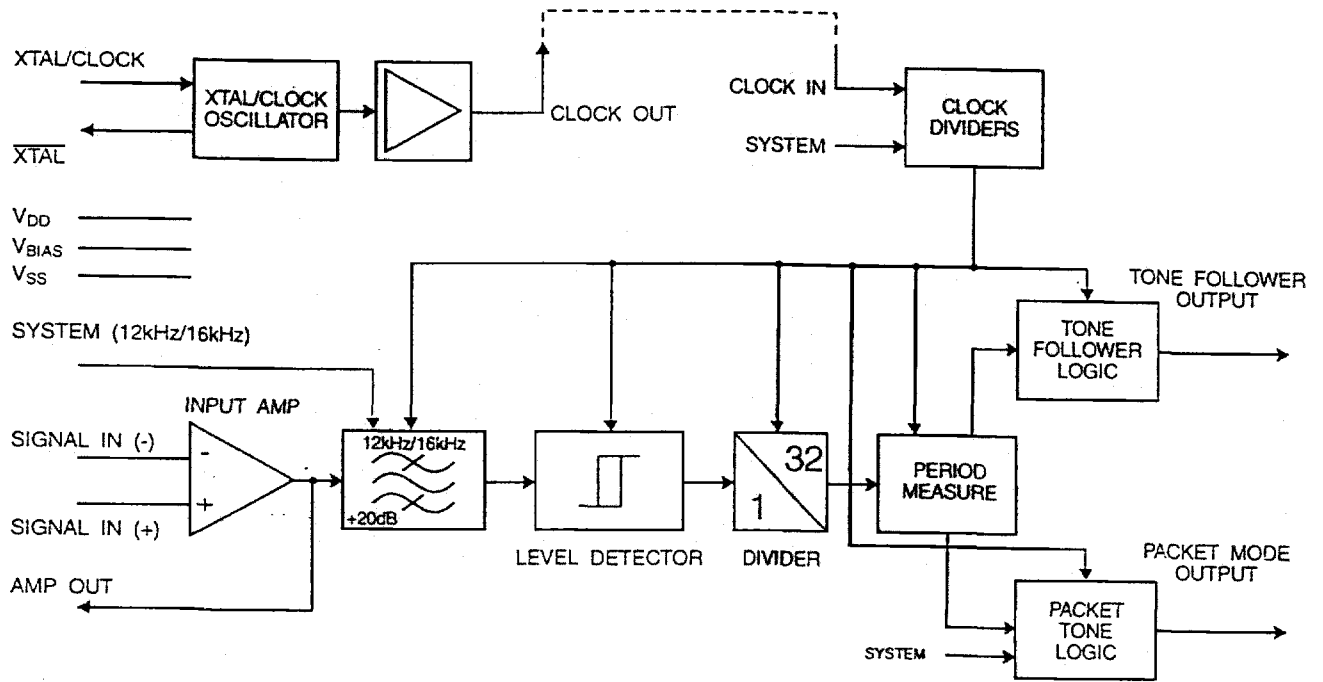

Figure 1: Block Diagram

2. Signal List

Packages		Signal		Description
D5/E2	D4/P3	Name	Type	
1	1	Xtal/Clock	input	The input to the on-chip clock oscillator; for use with a 3.579545MHz Xtal in conjunction with the Xtal output; circuit components are on-chip. When using a Xtal input, the Clock Out pin should be connected directly to the Clock In pin. If a clock pulse input is used at the Clock In pin, this (Xtal/Clock) pin must be connected directly to V _{DD} . See Figure 2 and Section 3.
4	2	XTAL	output	The output of the on-chip clock oscillator inverter.
5	3	Clock Out	output	The buffered output of the on-chip-clock oscillator inverter. If a Xtal input is used, this output should be connected directly to the Clock In pin.
6	4	Clock In	input	The 3.579545 clock pulse input to the internal clock dividers. If an externally generated clock pulse is used, the Xtal/Clock input pin should be connected to V _{DD} . Reference Section 3.
8	7	V _{BIAS}	power	The output of the on-chip analog bias circuitry. Held internally at V _{DD} /2, this pin should be bypassed to V _{SS} . See Figure 2.
12	8	V _{SS}	power	Negative supply (GND).
13	9	Signal In +	input	The positive input to the input gain adjusting signal amplifier. Reference Section 4.3 and 4.4.
17	10	Signal In -	input	The negative input to the input gain adjusting signal amplifier. Reference Section 4.3 and 4.4.
18	11	Amp Out	input	The output of the input gain adjusting signal amplifier. Reference Section 4.3 and 4.4.
19	13	Tone Follower Mode	output	This output provides a logic 0 for the period of a detected tone and a logic 1 for a NOTONE detection. See Section 4.1 and Figure 3.
20	14	Packet Mode	output	This output provides a logic 0 for a detected tone and a logic 1 for NOTONE detection and will ignore a small fluctuation or fade during the tone signal. See Section 4.2 and Figure 3.
21	15	System	input	This logic input selects the device operation to either 12kHz (logic 1) or 16kHz (logic 0) SPM systems. This input has an internal 1M Ω pull-up resistor (12kHz).
24	16	V _{DD}	power	Positive supply. A single, stable power supply is required. Critical levels and voltages within the CMX631A are dependent upon this supply. This pin should be bypassed to V _{SS} by a capacitor mounted close to the pin. Note: If this device is line powered, the resulting power supply must be stable. See Section 5.1.1.
2,3,7,9,10 11,14,15 16,22,23	5,6,12	N/C		No internal connection; leave open circuit.

Table 1: Signal List

3. External Components

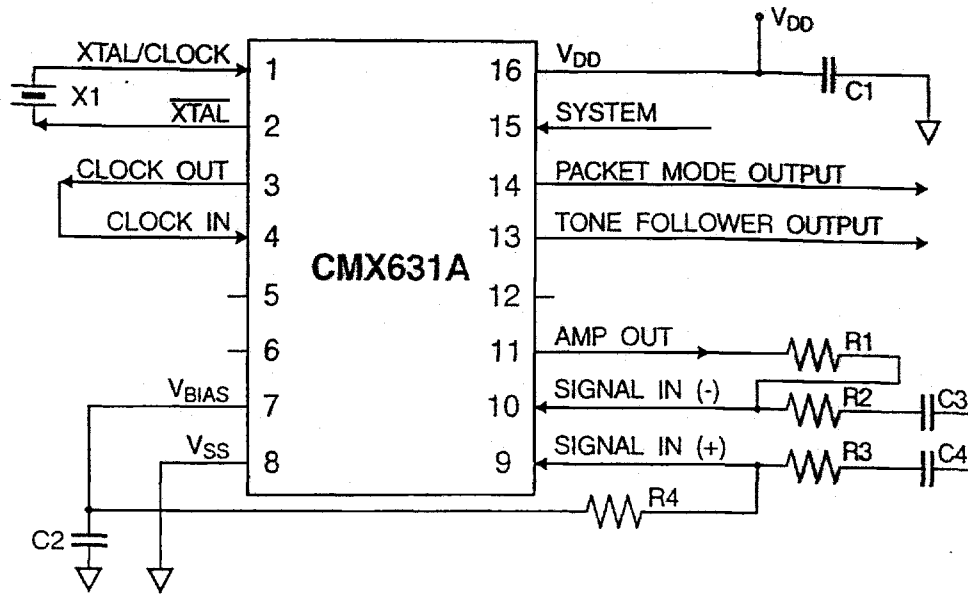

Figure 2: Recommended External Components

R1	Note 1	$R_{FEEDBACK}$	
R2	Note 1	$R_{IN(-)}$	
R3	Note 1	$R_{IN(+)}$	
R4	Note 1	R_{BIAS}	
C1		1.0 μ F	$\pm 20\%$
C2		1.0 μ F	$\pm 20\%$
C3		$C_{IN(-)}$	
C4		$C_{IN(+)}$	
X1	Note 2, 3, 4	3.579545MHz	

Table 2: Recommended External Components

Recommended External Component Notes:

1. When calculating input gain components, for correct operation R1 and R4 should **always** be $\geq 100k\Omega$.
2. For best results, a crystal oscillator design should drive the clock inverter input with signal levels of at least 40% of V_{DD} , peak to peak. Tuning fork crystals generally cannot meet this requirement. To obtain crystal oscillator design assistance, consult your crystal manufacturer.
3. The on-chip crystal circuitry includes a feedback resistor (nominally 2M Ω) between pins 1 & 2 and load capacitors on pins 1 & 2 (nominally 10pF each, excluding package and board parasitics).
4. When using an external clock input, X1 should be removed, Pin 1 (Xtal/Clock) should be tied to V_{DD} , the Clock In and Clock Out jumper should be removed, and the external clock signal applied to Clock In.

4. General Description

4.1 Tone Follower Mode

The Tone Follower Output Mode will respond and/or de-respond when a signal is detected or a NOTONE, by providing a Logic level output. When a signal has been detected, a Logic 0 is provided at the output for the duration of the valid signal. When a NOTONE or invalid decode is detected a Logic 1 is provided at the output until a valid signal is available. See Figure 3.

4.2 Packet Mode

The Packet (Cumulative Tone) Mode Output will respond and/or de-respond after a cumulative 40ms of good tone (or NOTONE) in any 48ms period by providing a Logic level output. See Figure 3

This process does ignore the small fluctuations or fades of a valid frequency input. During a 40ms toneburst, no tone interruption (small fluctuation or fade) is allowed during this period for the signal to be considered valid. If a 45ms toneburst occurs, then a 2ms interruption is allowed, and the signal is still considered valid. For NOTONE, there must be 40ms of continuous no tone or for a 45ms period, there may be 2ms of tone and the NOTONE still be valid. For a valid detect of tone the output provides a Logic 0. For the valid detect of NOTONE, the output provides a Logic 1.

This output is available for μ Processor 'Wake-Up', Minimum Tone detection, NOTONE indication, or transient avoidance.

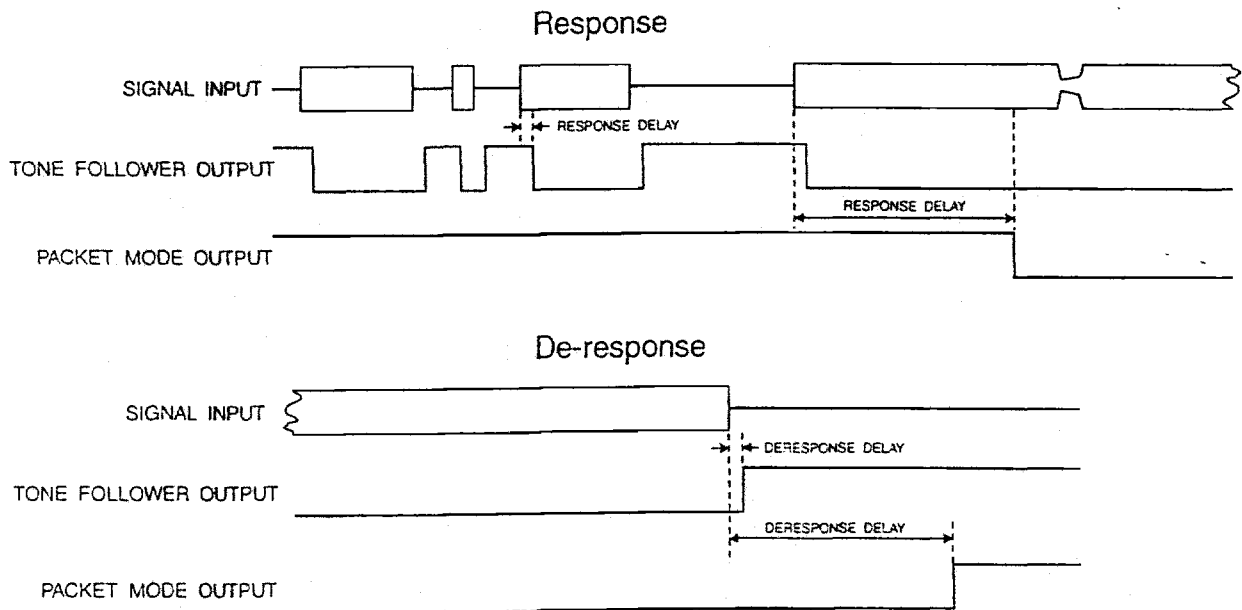

Figure 3: Tone Follower and Packet Mode Outputs

4.3 Sensitivity Setting

The CMX631A input sensitivity can be accurately adjusted and set to support many national 12kHz and 16kHz SPM specifications.

4.3.1 Input Gain Calculation

The input amplifier, with external circuitry, is used to set the sensitivity of the CMX631A to conform to the user's national level specification with regard to 'Must' and 'Must-Not' decode signal levels.

With reference to the graph in Figure 4, the following steps will assist in the determination of the required gain/attenuation.

1. Draw two horizontal lines from the Y-axis [Signal Level (dB)] in Figure 4. The upper line represents the required 'Must' decode level. The lower line represents the required 'Must-Not' decode level
2. Mark the intersection of the upper horizontal line and the upper sloping line; drop a vertical line from this point to the X-axis [Amplifier Gain (dB)]. The point where the vertical line meets the X-axis indicates the minimum Input Amp gain required for reliable decoding of valid signals

3. Mark the intersection of the lower horizontal line and the lower sloping line; drop a vertical line from this point to the X-axis. The point where the vertical line meets the X-axis will indicate the maximum allowable Input Amp gain. Input signals at or below the 'Must-Not' decode level will not be detected as long as the amplifier gain is no higher than this level.

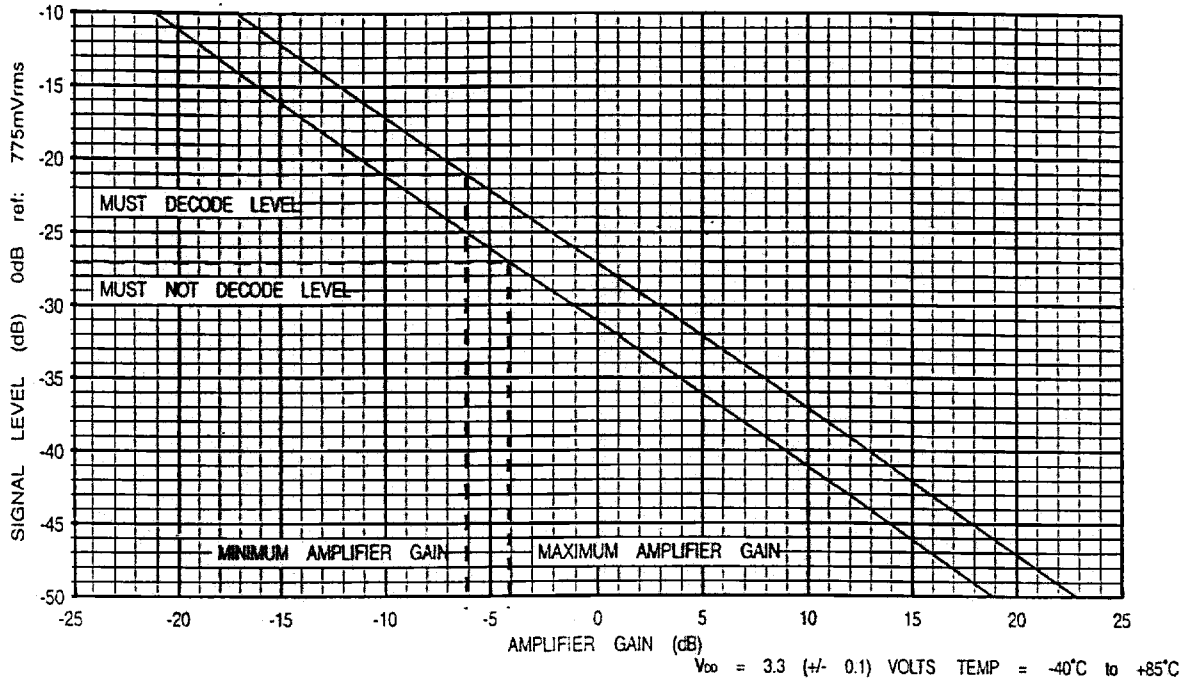

Figure 4: Input Gain Calculation Graph for $V_{DD} = 3.3V$

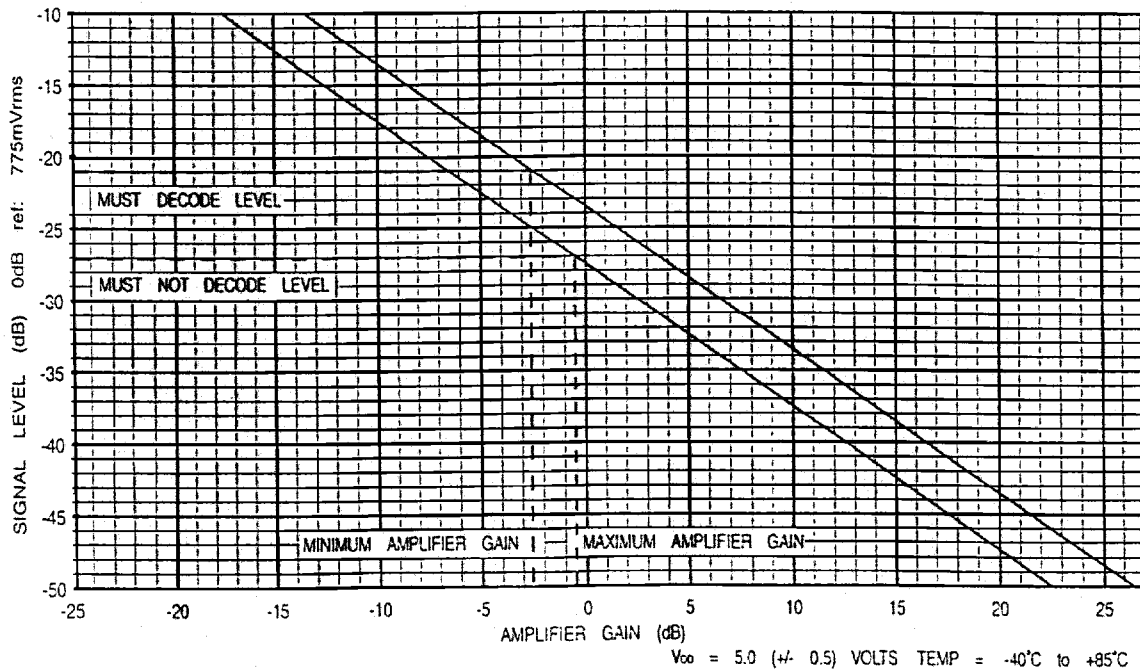

Figure 5: Input Gain Calculation Graph for $V_{DD} = 5.0V$

4.3.2 Input Gain Components

Reference the gain components found in Table 2 and Figure 2. The user should calculate and select external components (R1/R3/C3 and R2/R4/C4) to provide amplifier gain within the limits obtained in Steps 2 and 3.

Component tolerances should not move the gain-figure outside these limits. The graph in Figure 4 is for the calculation of input gain components for a CMX631A using a V_{DD} of 3.3 (± 0.1) or V_{DD} of 5.0 (± 0.5).

4.4 'Must'/'Must Not' Decode Frequencies

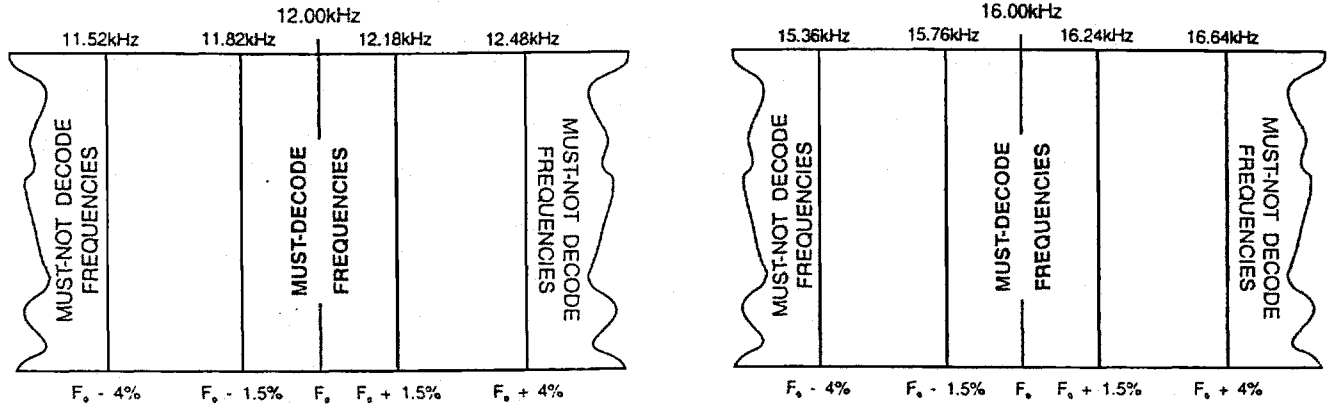

Figure 6: 'Must'/'Must Not' Decode Frequencies

5. Applications

5.1 Input Configurations

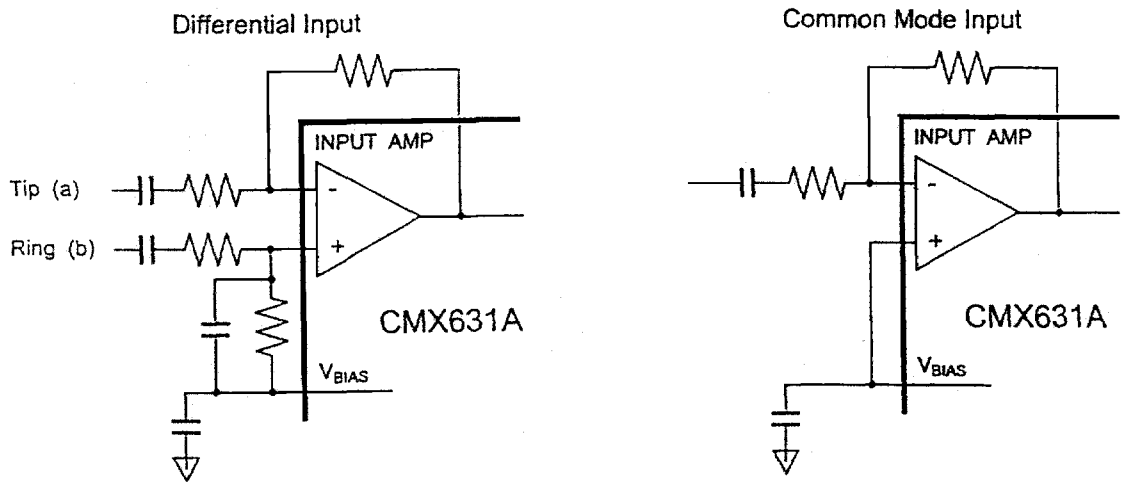

Figure 7: Input Configurations

5.1.1 Protection Against High Voltages

Telephone systems may have high DC and AC voltages present on the line. If the CMX631A is a part of host equipment that has its own signal input protection circuitry, there will be no need for further protection as long as the voltage on any pin is limited to within $V_{DD} + 0.3V$ and $V_{SS} - 0.3V$.

If the host system does not have input protection, or there are signals present outside the device's specified limits, the CMX631A will require protection diodes at its signal inputs (+ and -). The breakdown voltage of capacitors and the peak inverse voltage of the diodes must be sufficient to withstand the sum of the DC voltages plus all expected signal peaks.

5.1.2 Aliasing

Due to the sampling nature of switched-capacitor filters used in the CMX631A, high frequency noise or unwanted signals can alias into the passband, disrupting detection. External components must be chosen carefully to avoid alias effects.

Possible Alias Frequencies:

$$12\text{kHz Mode} = 52\text{kHz}$$

$$16\text{kHz Mode} = 69\text{kHz}$$

If other filtering in the system has not attenuated these alias frequencies, capacitors should be employed across resistors R3, R4, R7 and R8 to provide anti-alias filtering.

The low-pass cutoff frequency should be chosen to be approximately 20kHz to 25kHz for a 12kHz system, or 25kHz to 30kHz for a 16kHz system.

$$\text{i.e. } C = \frac{1}{2 \times \pi \times f_0 \times R3}$$

When anti-alias capacitors are used, an allowance must be made for reduced gain at the SPM frequency (12kHz or 16kHz).

6. Performance Specification

6.1 Electrical Specifications

6.1.1 Absolute Maximum Ratings

Exceeding the maximum rating can result in device damage.

Parameter	Min.	Typ.	Max.	Unit
Supply Voltage ($V_{DD}-V_{SS}$)	-0.3		7.0	V
Voltage on any pin to V_{SS}	-0.3		($V_{DD} + 0.3$)	V
Current				
V_{DD}	-30		30	mA
V_{SS}	-30		30	mA
Any other pin	-20		20	mA
D4 / P3 Packages				
Total allowable device dissipation at $T_{AMB} 25^{\circ}\text{C}$			800	mW
Derating above $T_{AMB} 25^{\circ}\text{C}$			10	mW/ $^{\circ}\text{C}$ above $T_{AMB} 25^{\circ}\text{C}$
Operating Temperature	-40		85	$^{\circ}\text{C}$
Storage Temperature	-40		85	$^{\circ}\text{C}$
D5 / E2 Packages				
Total allowable device dissipation at $T_{AMB} 25^{\circ}\text{C}$			550	mW
Derating above $T_{AMB} 25^{\circ}\text{C}$			9	mW/ $^{\circ}\text{C}$ above $T_{AMB} 25^{\circ}\text{C}$
Operating Temperature	-40		85	$^{\circ}\text{C}$
Storage Temperature	-40		85	$^{\circ}\text{C}$

6.1.2 Operating Limits

Correct Operation of the device outside these limits is not implied.

Parameter	Min.	Typ.	Max.	Unit
Supply Voltage (V_{DD})	3.0	3.3/5.0	5.5	V
Operating Temperature	-40		85	$^{\circ}\text{C}$
Xtal/Clock Frequency	3.558918		3.589368	MHz

6.1.3 Operating Characteristics

All device characteristics are measured under the following conditions unless otherwise specified:

$V_{DD} = 3.3V$ to $5.0V$ @ $T_{OP} = \text{Ambient}$

Audio Level 0dB (ref.) = $775mV_{RMS}$; Noise Bandwidth = 50kHz

Xtal/Clock Frequency = 3.579545MHz, System Setting = 12kHz or 16kHz

	Notes	Min.	Typ.	Max.	Units
Supply Current					
$V_{DD} = 3.3V$				1.0	mA
$V_{DD} = 5.0V$				2.0	mA
Logic Inputs/Outputs					
Input Logic '1'		70			% V_{DD}
Input Logic '0'				30	% V_{DD}
Output Logic '1'		90			% V_{DD}
Output Logic '0'				10	% V_{DD}
Xtal/Clock or Clock In Frequency		3.558918		3.589368	MHz
External Clock Pulse Width					
High		100			ns
Low		100			ns
Input Amplifier					
D. C. Gain		60.0			dB
Bandwidth (-3dB)			100		Hz
Input Impedance		1.0			$M\Omega$
Logic Impedances					
Input					
System		0.7		3.8	$M\Omega$
Clock In		10.0			$M\Omega$
Output			14.0	30.0	$k\Omega$
Overall Performance					
12kHz Detect Bandwidth	1	11.820		12.180	kHz
12kHz Not-detect Frequencies (Below 12kHz)	1			11.520	kHz
12kHz Not-detect Frequencies (Above 12kHz)	1	12.480			kHz
16kHz Detect Bandwidth	1	15.760		16.240	kHz
16kHz Upper Decode Band Edge (Below 16kHz)	1			15.360	kHz
16kHz Lower Decode Band Edge (Above 16kHz)	1	16.640			kHz
Sensitivity	2	7.8	10.0	15.5	mV_{P-P}
Tone Operating Characteristics					
Signal-to-Noise Requirements (Amp Input)	3, 4, 5, 6	22.0	20.0		dB
Signal-to-Voice Requirements (Amp Input)	3, 4, 5, 7	-36.0	-40.0		dB
Signal-to-Voice Requirements (Amp Output)	5, 6	-25.0		-29.0	dB
Tone Follower Mode	1, 8				
Response and De-Response Time				10.0	ms
Packet Mode	1, 8				
Response and De-Response Time		40.0		48.0	ms

Table 3: Operating Characteristics

Operating Characteristics Notes:

1. With adherence to Signal-to-Voice and Signal-to-Noise specifications.
2. With Input Amp gain setting: 15.5dB_{MIN}/18.0dB_{MIN}.
3. Common Mode SPM and balanced voice signal.
4. Immune to false responses.
5. Immune to false de-responses.
6. With SPM and voice signal amplitudes balanced. To avoid false de-responses due to saturation, the peak to peak voice+noise level at the output of the Input Amp (12/16kHz Filter Input) should be no greater than the dynamic range of the device.
7. Maximum voice frequencies = 3.4kHz.
8. Response, De-Response, and Power-up Response timing.

6.2 Packages

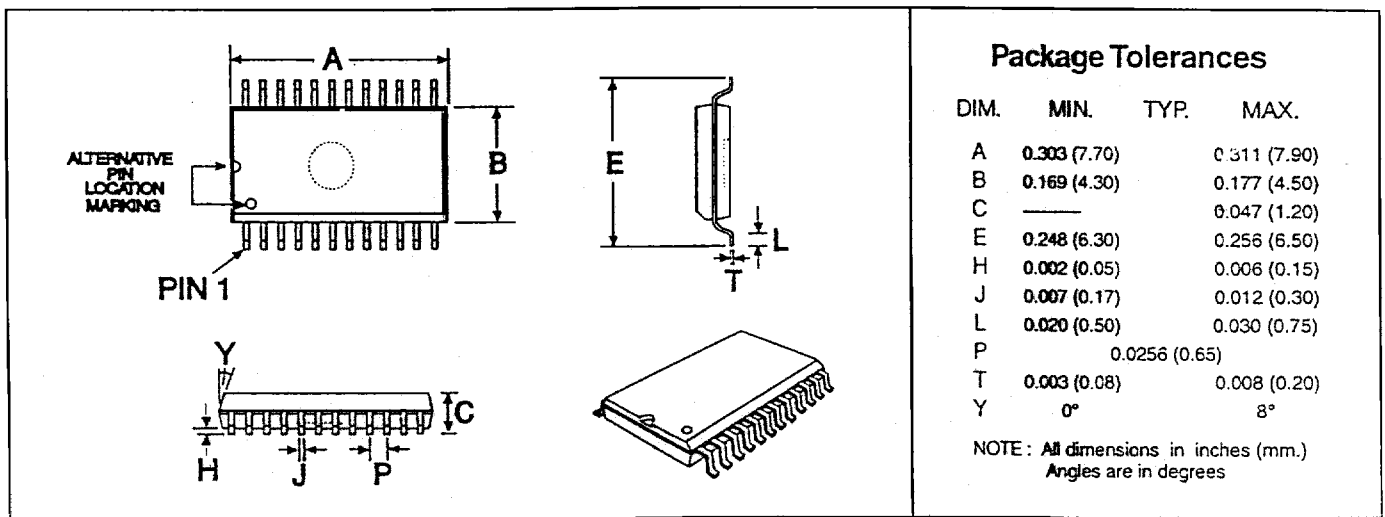

Figure 8: 24-pin TSSOP Mechanical Outline: order as part no. CMX631AE2

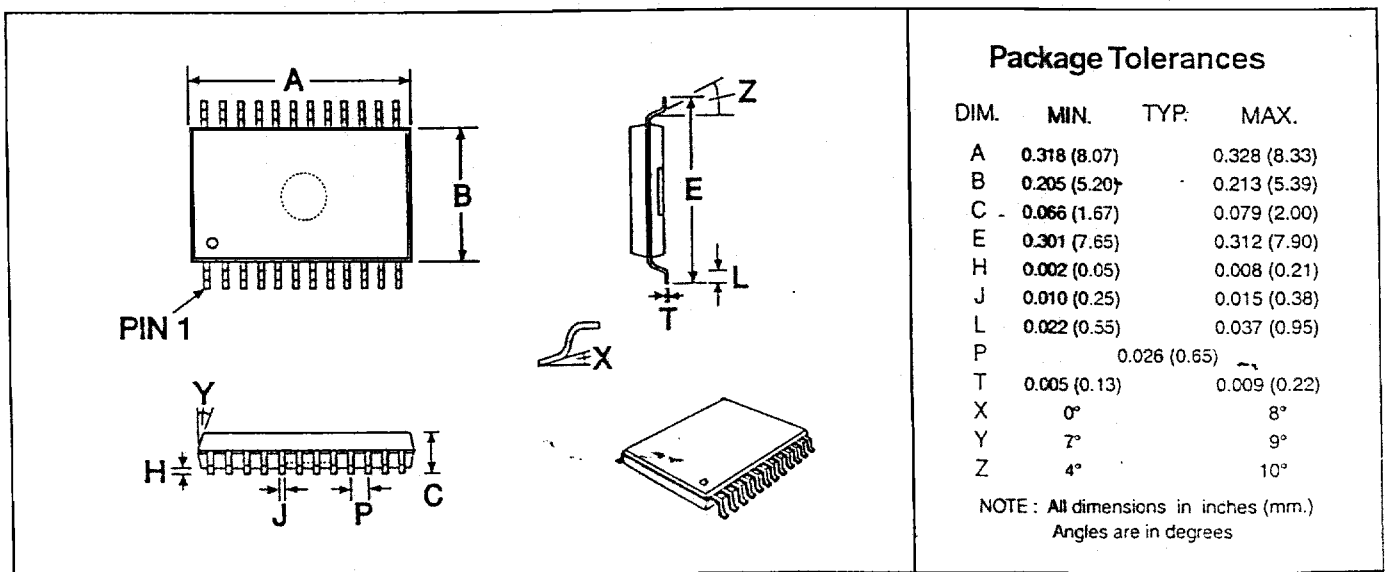

Figure 9: 24-pin SSOP Mechanical Outline: order as part no. CMX631AD5

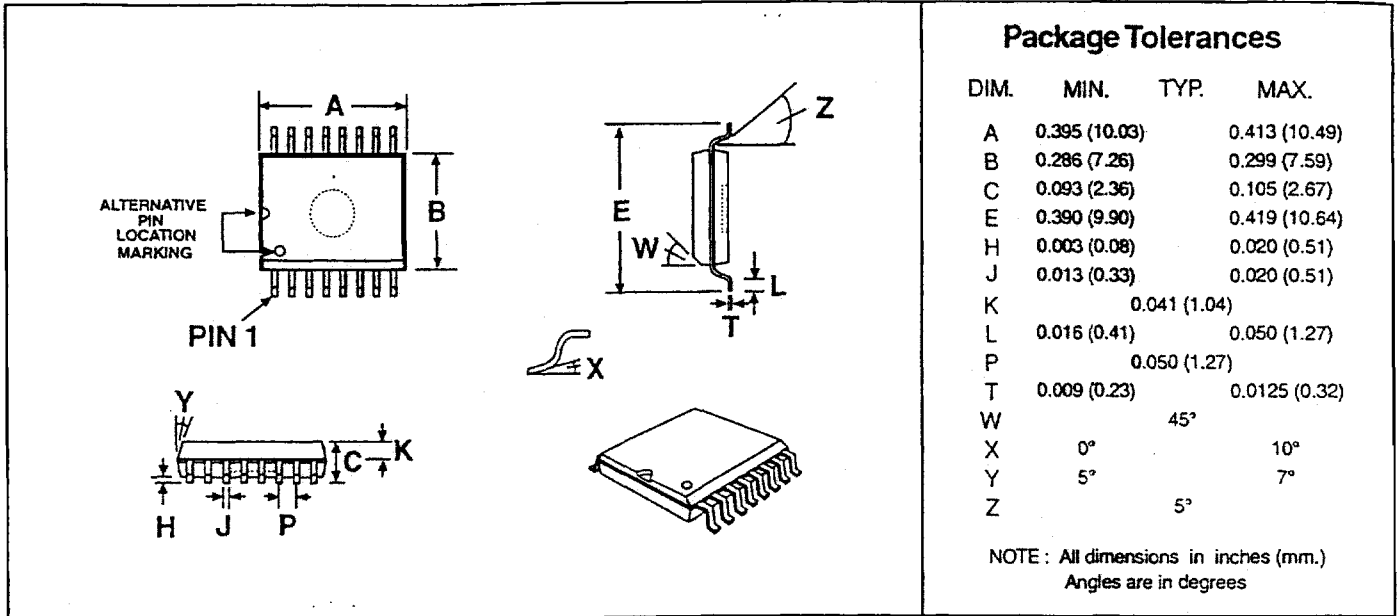

Figure 10: 16-pin SOIC Mechanical Outline: order as part no. CMX631AD4

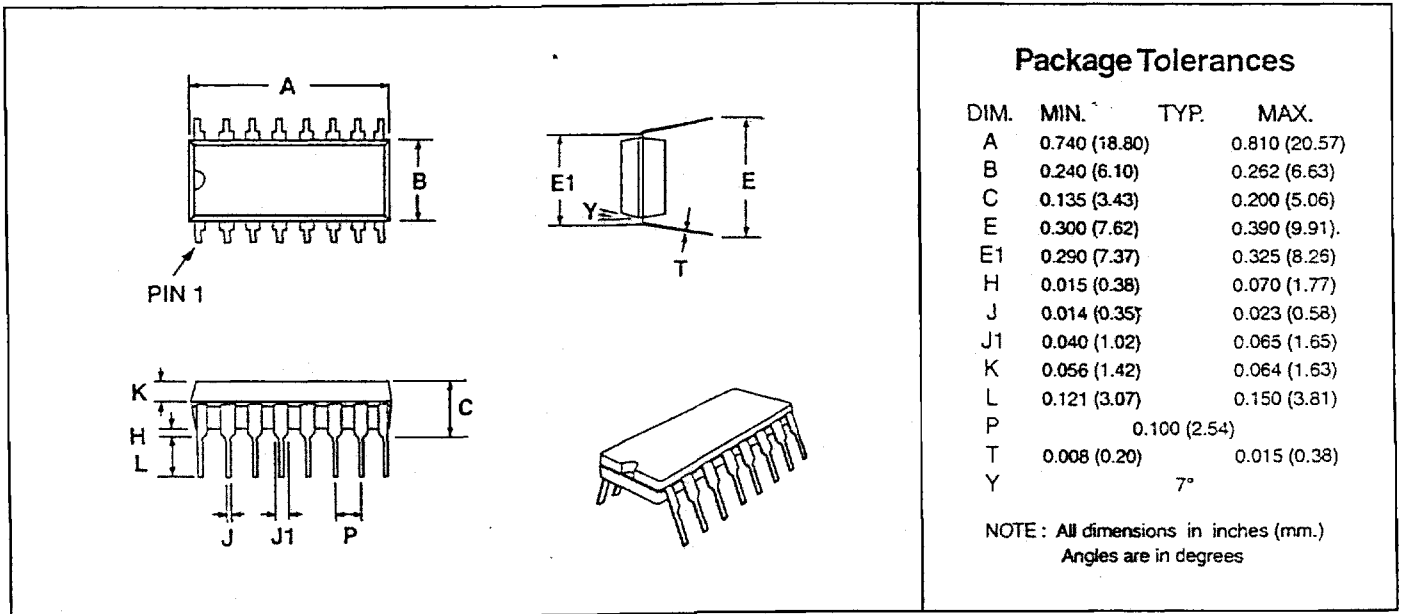

Figure 11: 16-pin PDIP Mechanical Outline: order as part no. CMX631AP3