



PRELIMINARY

CYM74BP54
CYM74P54/55
CYM74SP54/55

Intel® 82430NX Chipset
Level II Cache Module Family

Features

- Pin-compatible secondary cache module family
- Asynchronous (CYM74BP54), synchronous pipelined (CYM74P54, CYM74P55), or synchronous (CYM74SP54, CYM74SP55) configurations with presence and configuration detect pins
- Ideal for Intel® P54C-based systems with the 82430NX (Neptune) chipset
- Operates at 60 and 66 MHz
- Uses cost-effective CMOS asynchronous SRAMs or high-performance synchronous SRAMs
- 160-position Burndy DIMM CELP2X80SC3Z48 connector
- 3.3V inputs/outputs

Functional Description

This family of secondary cache modules is designed for Intel P54C systems with the 82430NX (Neptune) chipset.

CYM74BP54 is an asynchronous 256-Kbyte cache module that provides a low-cost, high-performance solution with in-

dustrial standard 5V SRAMs and 3.3V level translators for CPU bus speeds up to 66 MHz. The CYM74BP54 is organized as 32K by 64-bits.

The synchronous modules are available with low-cost synchronous pipelined RAMs or higher performance synchronous burst RAMs. The synchronous pipelined modules are based on a 16Kx64 RAM. The CYM74P54 is a 256-KB module while the CYM74P55 is a 512-KB module. Both are modules without byte parity.

The CYM74SP54 and CYM74SP55 are synchronous burst cache modules that provide zero wait-state performance at a bus speed of 66 MHz. The CYM74SP54 is a 256-Kbyte cache module with byte parity. The CYM74SP55 is a 512-Kbyte cache module with byte parity.

Multiple ground pins and on-board decoupling capacitors ensure high performance with maximum noise immunity.

All components on the cache modules are surface mounted on a multi-layer epoxy laminate (multifunctional) substrate. The contact pins are plated with 150 micro-inches of nickel covered by 10 micro-inches of gold flash.

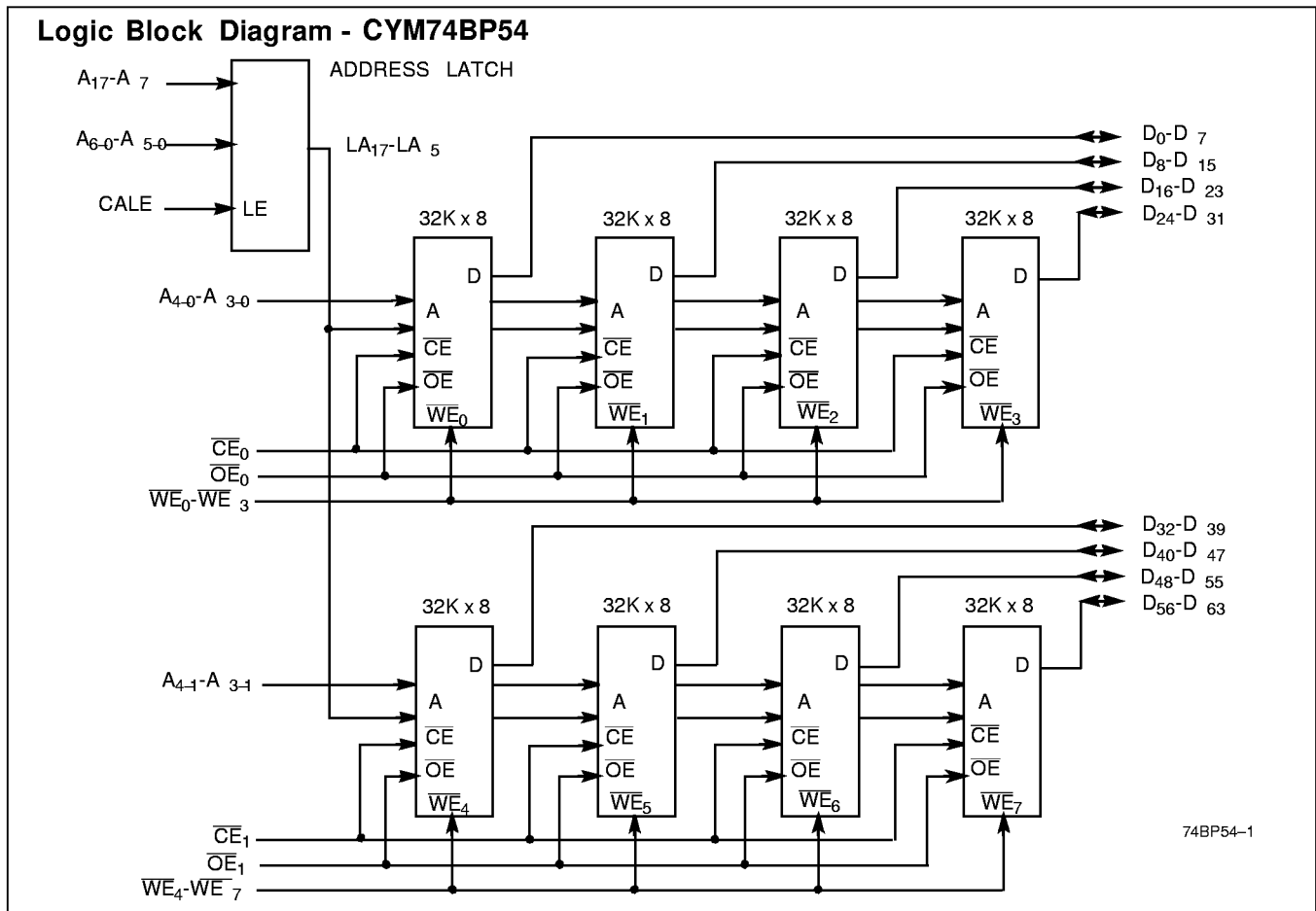

Intel is a registered trademark of Intel Corporation.



PRELIMINARY

CYM74BP54
CYM74P54/55
CYM74SP54/55

Block Diagram: 5V to 3.3V Level Conversion (CYM74BP54)

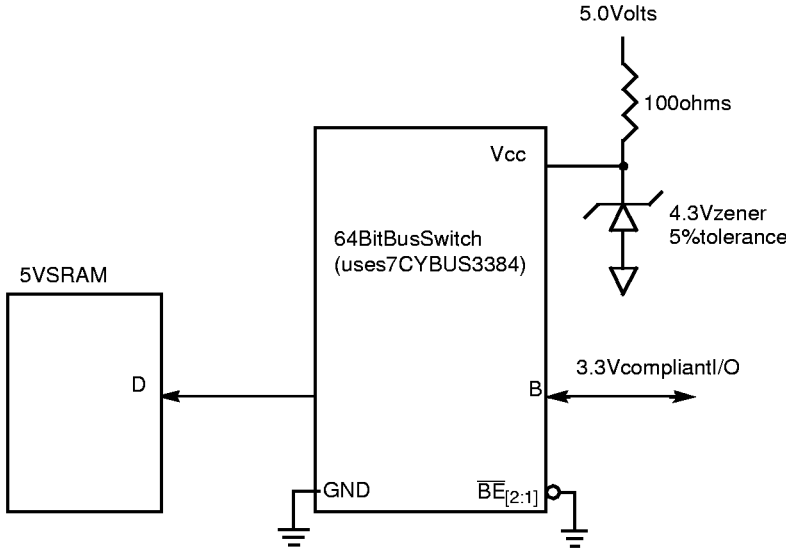

74BP54-2

Logic Block Diagram - CYM74P54, CYM74P55

	PD ₂	PD ₁	PD ₀
CYM74P54	TBD	TBD	TBD
CYM74P55	TBD	TBD	TBD

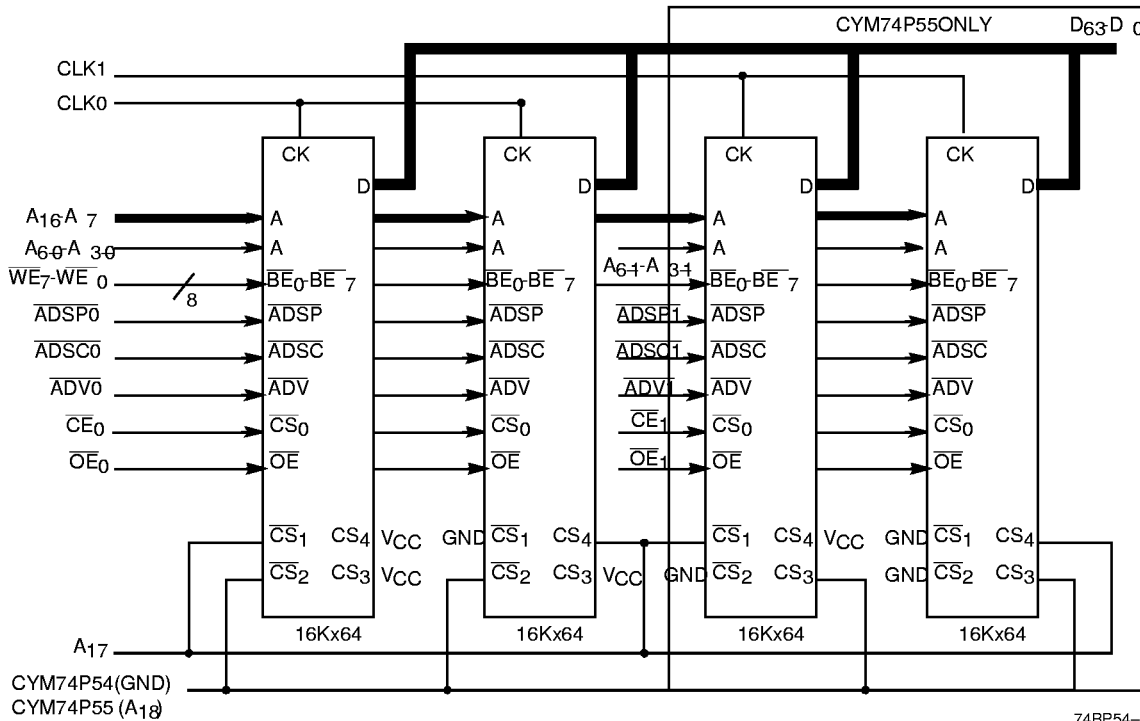

74BP54-3

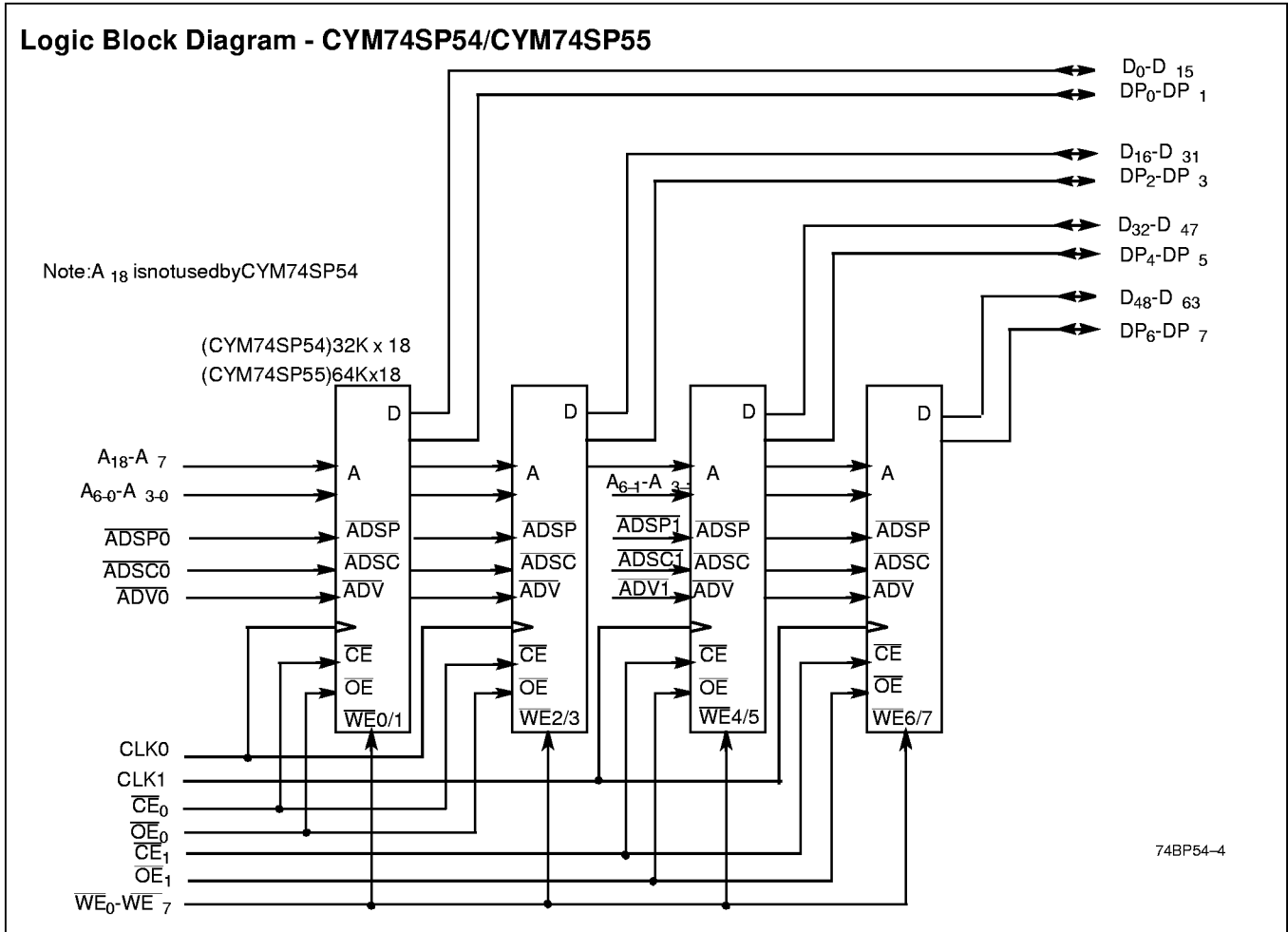

Selection Guide

Part Number	Asynchronous Cache Modules	
	CYM74BP54-60	CYM74BP54-66
Cache Size (KB)	256	
System Clock (MHz)	60	66
RAM Speed	t _{AA} =15 ns	t _{AA} =12 ns

Part Number	Synchronous Pipelined Cache Modules			
	CYM74P54-60	CYM74P54-66	CYM74P55-60	CYM74P55-66
Cache Size (KB)	256		512	
System Clock (MHz)	60	66	60	66
RAM Speed	t _{CDV} =10.5 ns	t _{CDV} =8.5 ns	t _{CDV} =10.5 ns	t _{CDV} =8.5 ns

Part Number	Synchronous Burst Cache Modules			
	CYM74SP54-60	CYM74SP54-66	CYM74SP55-60	CYM74SP55-66
Cache Size (KB)	256		512	
System Clock (MHz)	60	66	60	66
RAM Speed	t _{CDV} =10.5 ns	t _{CDV} =8.5 ns	t _{CDV} =10.5 ns	t _{CDV} =8.5 ns



Pin Configuration

Dual Read-Out SIMM (DIMM)

Top View

GND	81	1	GND
D ₆₃	82	2	D ₆₂
V _{CC}	83	3	NC (74BP54) / V _{CCQ} (74P5X, 74SP5X)
D ₆₁	84	4	D ₆₀
V _{CC}	85	5	NC (74BP54) / V _{CCQ} (74P5X, 74SP5X)
D ₅₉	86	6	D ₅₈
D ₅₇	87	7	D ₅₆
GND	88	8	GND
(74P5X, 74SP5X) DP ₇ / (74BP54) NC	89	9	NC (74BP54) / DP ₆ (74P5X, 74SP5X)
D ₅₅	90	10	D ₅₄
D ₅₃	91	11	D ₅₂
D ₅₁	92	12	D ₅₀
GND	93	13	GND
D ₄₉	94	14	D ₄₈
D ₄₇	95	15	D ₄₆
D ₄₅	96	16	D ₄₄
D ₄₃	97	17	D ₄₂
GND	98	18	GND
D ₄₁	99	19	D ₄₀
(74P5X, 74SP5X) DP ₅ / (74BP54) NC	100	20	NC (74BP54) / DP ₄ (74P5X, 74SP5X)
D ₃₉	101	21	D ₃₈
D ₃₇	102	22	D ₃₆
D ₃₅	103	23	D ₃₄
GND	104	24	GND
D ₃₃	105	25	D ₃₂
D ₃₁	106	26	D ₃₀
D ₂₉	107	27	D ₂₈
D ₂₇	108	28	D ₂₆
D ₂₅	109	29	D ₂₄
GND	110	30	GND
(74P5X, 74SP5X) DP ₃ / (74BP54) NC	111	31	NC (74BP54) / DP ₂ (74P5X, 74SP5X)
D ₂₃	112	32	D ₂₂
D ₂₁	113	33	D ₂₀
V _{CC}	114	34	NC (74BP54) / V _{CCQ} (74P5X, 74SP5X)
D ₁₉	115	35	D ₁₈
GND	116	36	GND
D ₁₇	117	37	D ₁₆
V _{CC}	118	38	NC (74BP54) / V _{CCQ} (74P5X, 74SP5X)
D ₁₅	119	39	D ₁₄
D ₁₃	120	40	D ₁₂
GND	121	41	GND
D ₁₁	122	42	D ₁₀
V _{CC}	123	43	NC (74BP54) / V _{CCQ} (74P5X, 74SP5X)
D ₉	124	44	D ₈
(74P5X, 74SP5X) DP ₁ / (74BP54) NC	125	45	NC (74BP54) / DP ₀ (74P5X, 74SP5X)
V _{CC}	126	46	NC (74BP54) / V _{CCQ} (74P5X, 74SP5X)
D ₇	127	47	D ₆
D ₅	128	48	D ₄
D ₃	129	49	D ₂
D ₁	130	50	D ₀
GND	131	51	GND
A ₃₋₁	132	52	A ₃₋₀
A ₄₋₁	133	53	A ₄₋₀
(74P5X, 74SP5X) A ₅₋₁ / (74BP54) NC	134	54	A ₅₋₀
(74P5X, 74SP5X) A ₆₋₁ / (74BP54) NC	135	55	A ₆₋₀
A ₇	136	56	A ₈
GND	137	57	GND
A ₉	138	58	A ₁₀
A ₁₁	139	59	A ₁₂
A ₁₃	140	60	A ₁₄
A ₁₅	141	61	A ₁₆
A ₁₇	142	62	NC (74BP54, 74SP54) / GND (74P54) / A ₁₈ (74P55, 74SP55)
GND	143	63	GND
(Reserved A ₁₉) NC	144	64	PD ₀
PD ₁	145	65	PD ₂
(74P5X, 74SP5X) CLK ₀ / (74BP54) NC	146	66	NC (74BP54, 74P54) / CLK ₁ (74P55, 74SP5X)
(Reserved CLK ₂) NC	147	67	NC (Reserved CLK ₃)
GND	148	68	GND
WE ₇	149	69	WE ₆
WE ₅	150	70	WE ₄
WE ₃	151	71	WE ₂
WE ₁	152	72	WE ₀
GND	153	73	GND
(74P55, 74SP5X) $\overline{\text{ADSC}}_1$ / (74BP54, 74P54) NC	154	74	CALE (74BP54) / $\overline{\text{ADSC}}_0$ (74P5X, 74SP5X)
CE ₁	155	75	CE ₀
(74P55, 74SP5X) $\overline{\text{ADV}}_1$ / (74BP54, 74P54) NC	156	76	NC (74BP54) / $\overline{\text{ADV}}_0$ (74P5X, 74SP5X)
OE ₁	157	77	OE ₀
V _{CC}	158	78	NC (74BP54) / V _{CCQ} (74P5X, 74SP5X)
(74P55, 74SP5X) $\overline{\text{ADSP}}_1$ / (74BP54, 74P54) NC	159	79	NC (74BP54) / $\overline{\text{ADSP}}_0$ (74P5X, 74SP5X)
GND	160	80	GND

74BP54-5



Pin Definitions

Common Signals	Description
V _{CC}	5V Supply
GND	Ground
A ₇ –A ₁₉	Addresses from processor
A ₃₋₀ , A ₄₋₀	Lower address from chipset, identical to the bank1 addresses
A ₃₋₁ , A ₄₋₁	Lower address from chipset, identical to the bank0 addresses, A ₃₋₁ , A ₄₋₁ not used on CYM74P54
A ₅₋₀ , A ₆₋₀	Lower address from processor (CYM74P5X, CYM74SP5X- identical to the bank1 addresses)
CE ₀ , CE ₁	Chip Enable (same signal), CE ₁ not used on CYM74P54
OE ₀ , OE ₁	Output Enable (same signal), OE ₁ not used on CYM74P54
WE ₀ , WE ₁ , WE ₂ , WE ₃ WE ₄ , WE ₅ , WE ₆ , WE ₇	Byte Write Enables
PD ₀ –PD ₂	Presence Detect pins
D ₀ –D ₆₃	Data lines from processor
NC	Signal not connected on module.
CYM74BP54 Only Signals	Description
CALE	Latch Enable
CYM74P5X, CYM74SP5X Signals	Description
V _{CCQ}	3.3V Supply
DP ₀ –DP ₇	Data Parity lines (Optional)
ADSP ₀ , ADSP ₁	Processor Address Strobe, ADSP ₁ not used on CYM74P54
ADSC ₀ , ADSC ₁	Cache Controller Address Strobe, ADSC ₁ not used on CYM74P54
ADV ₀ , ADV ₁	Burst Address Advance, ADV ₁ not used on CYM74P54
A ₅₋₁ , A ₆₋₁	Lower address from processor, identical to the bank0 addresses, A ₅₋₁ , A ₆₋₁ not used on CYM74P54
CLK0, CLK1, CLK2, CLK3	Clock signals (each should be given own clk driver); CLK0 used on CYM74P5X, CYM74SP5X; CLK1 not used on CYM74P54; CLK2 and CLK3 are RSVD

Presence Detect Pins

	PD ₂	PD ₁	PD ₀
Asynchronous – CYM74BP54	NC	GND	NC
Synchronous Pipelined – CYM74P54	TBD	TBD	TBD
Synchronous Pipelined – CYM74P55	TBD	TBD	TBD
Synchronous Burst – CYM74SP54	GND	GND	NC
Synchronous Burst – CYM74SP55	GND	GND	GND



Maximum Ratings

(Above which the useful life may be impaired. For user guidelines, not tested.)

Storage Temperature -55°C to +125°C
 Ambient Temperature
 with Power Applied -0°C to +70°C
 3.3V Supply Voltage to Ground Potential..... -0.5V to +5.25V
 5V Supply Voltage to Ground Potential..... -0.5V to +5.25V
 DC Voltage Applied to Outputs
 in High Z State -0.5V to +4.6V
 DC Input Voltage..... -0.5V to +4.6V

Output Current into Outputs (LOW)..... 20 mA

Operating Range

Range	Ambient Temperature	V _{CC}	V _{CCQ}
Commercial (CYM74BP54)	0°C to +70°C	5V ± 5%	N/A
Commercial (CYM74P5X, CYM74SP5X)	0°C to +70°C	5V ± 5%	5V ± 5% 3.3V + 10% - 5%

Electrical Characteristics Over the Operating Range

Parameter	Description	Test Condition	Min.	Max.	Unit
V _{IH}	Input HIGH Voltage		2.2		V
V _{IL}	Input LOW Voltage	CYM74BP54	-0.5	0.8	V
V _{IL}	Input LOW Voltage	CYM74P5X, CYM74SP5X	-0.3	0.8	V
V _{OH}	Output HIGH Voltage	V _{CC} =Min., I _{OH} = -4 mA	2.4		V
V _{OL}	Output LOW Voltage	V _{CC} =Min., I _{OL} = 8 mA		0.4	V
I _{CC} (74BP54)	V _{CC} Operating Supply Current	V _{CC} =Max., I _{OUT} =0 mA, f=f _{MAX} =1/t _{RC}		1700	mA
I _{CC} (74P54)	V _{CC} Operating Supply Current	V _{CC} =Max., I _{OUT} =0 mA, f=f _{MAX} =1/t _{RC}		TBD	mA
I _{CC} (74P55)	V _{CC} Operating Supply Current	V _{CC} =Max., I _{OUT} =0 mA, f=f _{MAX} =1/t _{RC}		TBD	mA
I _{CC} (74SP54)	V _{CC} Operating Supply Current	V _{CC} =Max., I _{OUT} =0 mA, f=f _{MAX} =1/t _{RC}		1100	mA
I _{CC} (74SP55)	V _{CC} Operating Supply Current	V _{CC} =Max., I _{OUT} =0 mA, f=f _{MAX} =1/t _{RC}		1400	mA

Ordering Information

Speed (MHz)	Ordering Code	Package Name	Package Type	Description	Operating Range
60	CYM74BP54PM-60	PM36	160-Pin Dual-Readout SIMM	Asynchronous 256KB	Commercial
	CYM74P54PM-60	TBD	160-Pin Dual-Readout SIMM	Synch Pipelined 256KB	
	CYM74P55PM-60	TBD	160-Pin Dual-Readout SIMM	Synch Pipelined 512KB	
	CYM74SP54PM-60	PM26	160-Pin Dual-Readout SIMM	Synch Burst 256KB	
	CYM74SP55PM-60	PM26	160-Pin Dual-Readout SIMM	Synch Burst 512KB	
66	CYM74BP54PM-66	PM36	160-Pin Dual-Readout SIMM	Asynchronous 256KB	Commercial
	CYM74P54PM-66	TBD	160-Pin Dual-Readout SIMM	Synch Pipelined 256KB	
	CYM74P55PM-66	TBD	160-Pin Dual-Readout SIMM	Synch Pipelined 512KB	
	CYM74SP54PM-66	PM26	160-Pin Dual-Readout SIMM	Synch Burst 256KB	
	CYM74SP55PM-66	PM26	160-Pin Dual-Readout SIMM	Synch Burst 512KB	

Document #: 38-M-00070-B



PRELIMINARY

CYM74BP54
CYM74P54/55
CYM74SP54/55

Package Diagrams

160-Pin Dual-Readout SIMM PM26

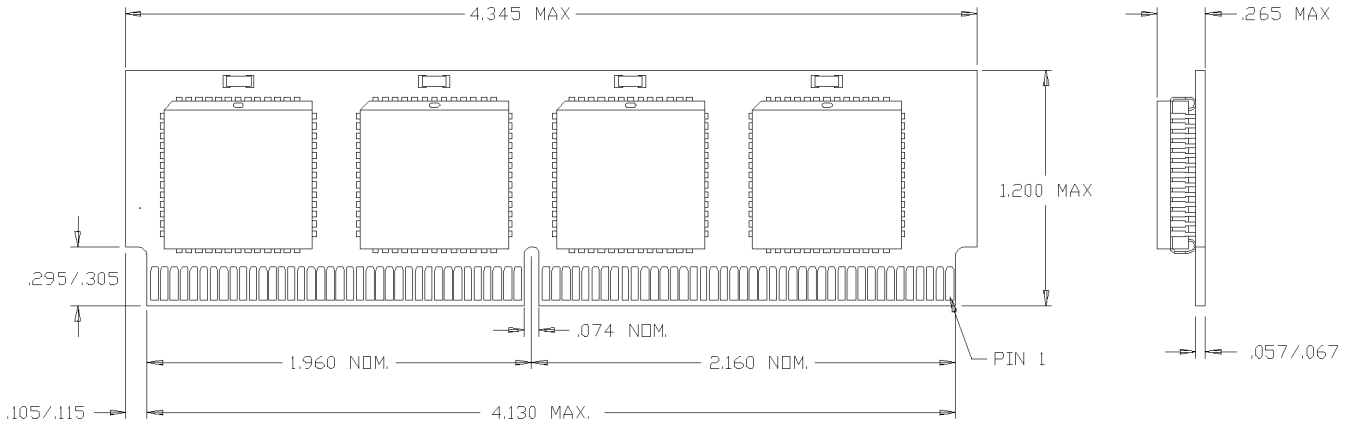

160-Pin Dual Readout SIMM PM36

