

# DATA SHEET

## **TDA9814T**

Multistandard VIF-PLL with QSS-IF  
and dual FM-PLL/AM demodulator

Product specification  
Supersedes data of 1995 Oct 03  
File under Integrated Circuits, IC02

1998 Feb 09

## Multistandard VIF-PLL with QSS-IF and dual FM-PLL/AM demodulator

## TDA9814T

### FEATURES

- 5 V supply voltage
- Gain controlled wide band VIF-amplifier (AC-coupled)
- True synchronous demodulation with active carrier regeneration (very linear demodulation, good intermodulation figures, reduced harmonics, excellent pulse response)
- Robustness for over-modulation better than 105% due to gated phase detector at L/L accent standard
- VCO frequency switchable between L and L accent (alignment external) picture carrier frequency
- Separate video amplifier for sound trap buffering with high video bandwidth
- VIF-AGC detector for gain control, operating as peak sync detector for B/G and peak white detector for L (optional external AGC); signal controlled reaction time for L
- Tuner AGC with adjustable takeover point (TOP)
- AFC detector without extra reference circuit
- AC-coupled limiter amplifier for sound intercarrier signal
- Two alignment-free FM-PLL demodulators with high linearity
- SIF input for single reference QSS mode (PLL controlled); SIF AGC detector for gain controlled SIF amplifier; single reference QSS mixer able to operate in high performance single reference QSS mode
- AM demodulator without extra reference circuit
- Stabilizer circuit for ripple rejection and to achieve constant output signals
- ESD protection for all pins.

### GENERAL DESCRIPTION

The TDA9814T is an integrated circuit for multistandard vision IF signal processing and sound AM and dual FM demodulation, with single reference QSS-IF in TV and VCR sets.

### ORDERING INFORMATION

TYPE NUMBER	PACKAGE		
	NAME	DESCRIPTION	VERSION
TDA9814T	SO28	plastic small outline package; 28 leads; body width 7.5 mm	SOT136-1

# Multistandard VIF-PLL with QSS-IF and dual FM-PLL/AM demodulator

TDA9814T

## QUICK REFERENCE DATA

SYMBOL	PARAMETER	CONDITIONS	MIN.	TYP.	MAX.	UNIT
$V_P$	supply voltage		4.5	5	5.5	V
$I_P$	supply current		93	109	125	mA
$V_{i\text{ VIF(rms)}}$	vision IF input signal voltage sensitivity (RMS value)	-1 dB video at output	-	60	100	$\mu\text{V}$
$V_{o\text{ CVBS(p-p)}}$	CVBS output signal voltage (peak-to-peak value)		1.7	2.0	2.3	V
$B_{-3}$	-3 dB video bandwidth on pin 8	B/G and L standard; $C_L < 20\text{ pF}$ ; $R_L > 1\text{ k}\Omega$ ; AC load	7	8	-	MHz
S/N (W)	weighted signal-to-noise ratio for video		56	60	-	dB
$IM_{\alpha 1.1}$	intermodulation attenuation at 'blue'	$f = 1.1\text{ MHz}$	58	64	-	dB
$IM_{\alpha 3.3}$	intermodulation attenuation at 'blue'	$f = 3.3\text{ MHz}$	58	64	-	dB
$\alpha_{H(\text{sup})}$	suppression of harmonics in video signal		35	40	-	dB
$V_{i\text{ SIF(rms)}}$	sound IF input signal voltage sensitivity (RMS value)	-3 dB at intercarrier output	-	30	70	$\mu\text{V}$
$V_{o(\text{rms})}$	audio output signal voltage for FM (RMS value)	B/G standard; 54% modulation	-	0.5	-	V
	audio output signal voltage for AM (RMS value)	L standard; 54% modulation	-	0.5	-	V
THD	total harmonic distortion	54% modulation				
	FM		-	0.15	0.5	%
	AM		-	0.5	1.0	%
S/N (W)	weighted signal-to-noise ratio	54% modulation				
	FM		-	60	-	dB
	AM		47	53	-	dB

Multistandard VIF-PLL with QSS-IF  
and dual FM-PLL/AM demodulator

TDA9814T

BLOCK DIAGRAM

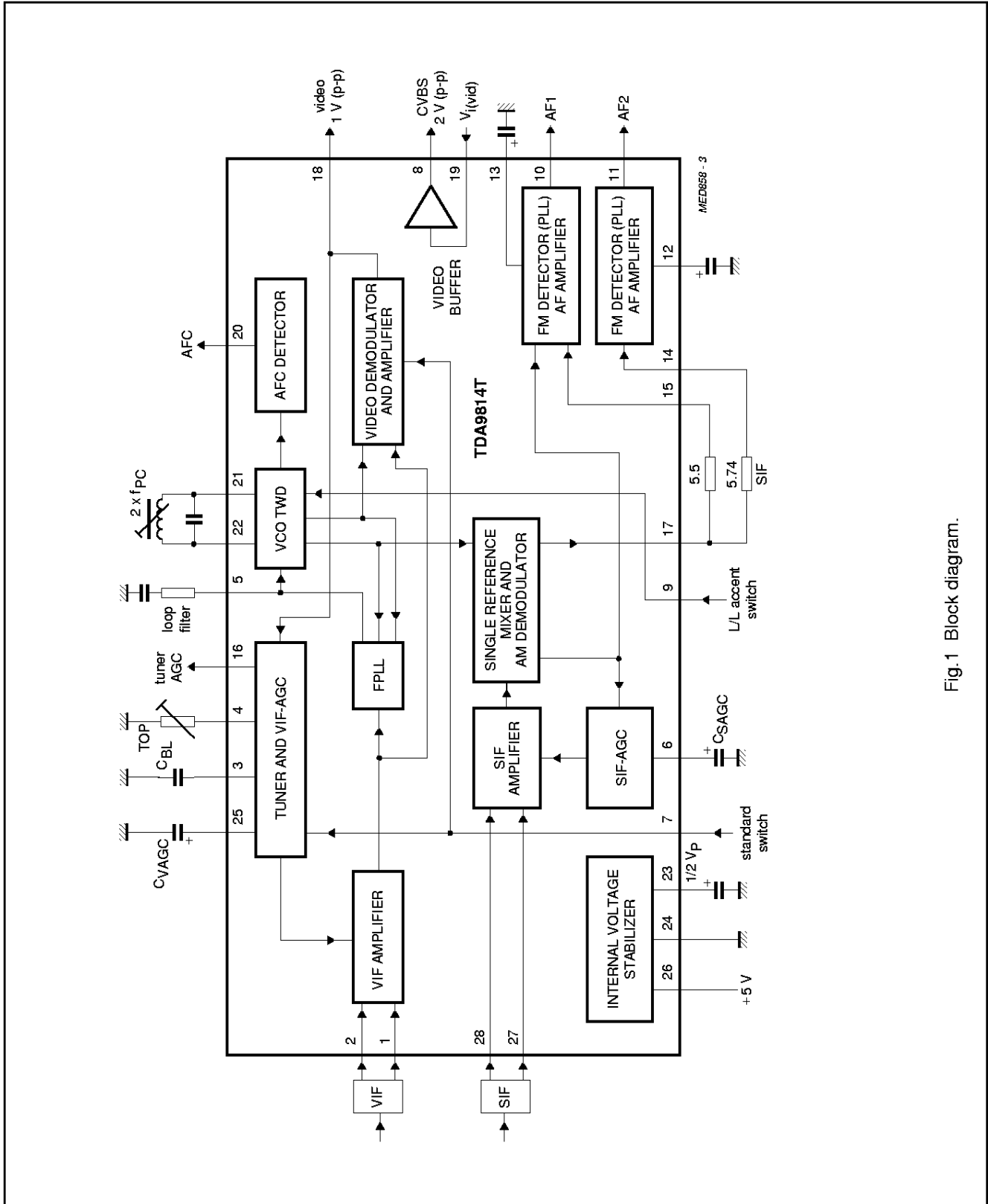

Fig.1 Block diagram.

Multistandard VIF-PLL with QSS-IF  
and dual FM-PLL/AM demodulator

TDA9814T

PINNING

SYMBOL	PIN	DESCRIPTION
$V_{i\ VIF1}$	1	VIF differential input signal voltage 1
$V_{i\ VIF2}$	2	VIF differential input signal voltage 2
$C_{BL}$	3	black level detector
TADJ	4	tuner AGC takeover adjust (TOP)
$T_{PLL}$	5	PLL loop filter
$C_{SAGC}$	6	SIF AGC capacitor
STD	7	standard switch
$V_{o\ CVBS}$	8	CVBS output signal voltage
LSWI	9	L/L accent switch
$V_{o\ AF1}$	10	audio voltage frequency output 1
$V_{o\ AF2}$	11	audio voltage frequency output 2
$C_{DEC2}$	12	decoupling capacitor 2
$C_{DEC1}$	13	decoupling capacitor 1
$V_{i\ FM2}$	14	sound intercarrier input voltage 2
$V_{i\ FM1}$	15	sound intercarrier input voltage 1
TAGC	16	tuner AGC output
$V_{o\ QSS}$	17	single reference QSS output voltage
$V_{o(vid)}$	18	composite video output voltage
$V_{i(vid)}$	19	video buffer input voltage
AFC	20	AFC output
VCO1	21	VCO1 reference circuit for $2f_{PC}$
VCO2	22	VCO2 reference circuit for $2f_{PC}$
$C_{ref}$	23	$\frac{1}{2}V_P$ reference capacitor
GND	24	ground
$C_{VAGC}$	25	VIF-AGC capacitor
$V_P$	26	supply voltage
$V_{i\ SIF1}$	27	SIF differential input signal voltage 1
$V_{i\ SIF2}$	28	SIF differential input signal voltage 2

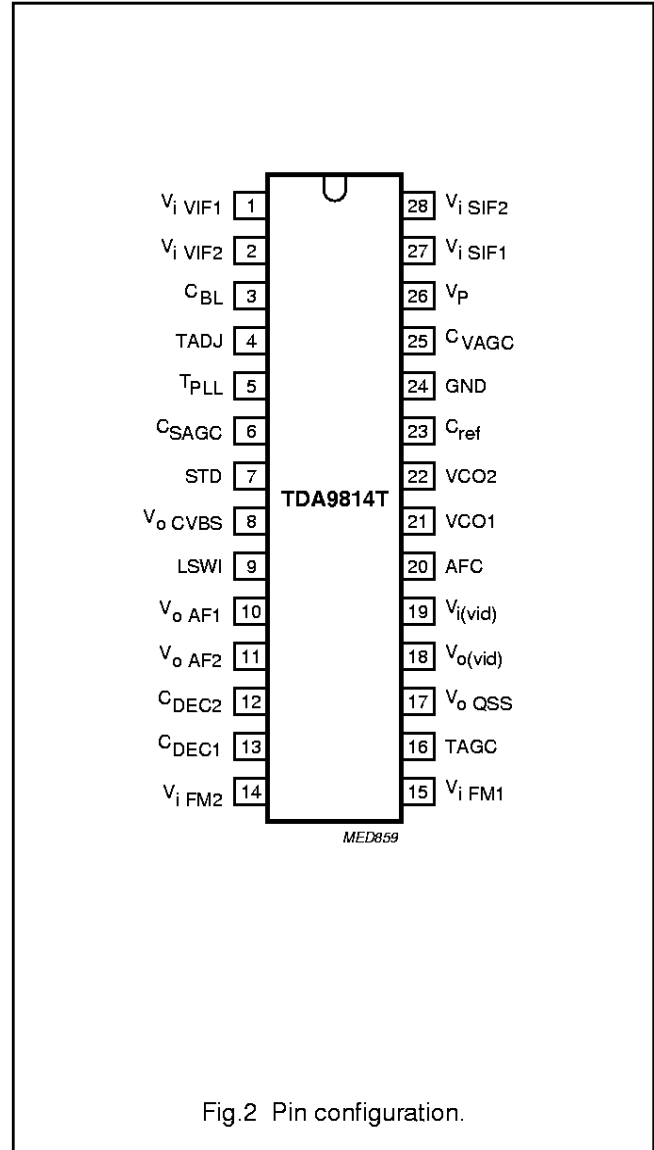

Fig.2 Pin configuration.

## Multistandard VIF-PLL with QSS-IF and dual FM-PLL/AM demodulator

TDA9814T

### FUNCTIONAL DESCRIPTION

The integrated circuit comprises the functional blocks as shown in Fig. 1:

- Vision IF amplifier
- Tuner and VIF-AGC
- Frequency Phase Locked Loop detector (FPLL)
- VCO, Travelling Wave Divider (TWD) and AFC
- Video demodulator and amplifier
- Video buffer
- SIF amplifier and AGC
- Single reference QSS mixer
- AM demodulator
- FM-PLL demodulator
- Internal voltage stabilizer and  $\frac{1}{2}V_P$ -reference.

#### Vision IF amplifier

The vision IF amplifier consists of three AC-coupled differential amplifier stages. Each differential stage comprises a feedback network controlled by emitter degeneration.

#### Tuner and VIF-AGC

The AGC capacitor voltage is transferred to an internal IF control signal, and is fed to the tuner AGC to generate the tuner AGC output current (open-collector output). The tuner AGC takeover point can be adjusted. This allows the tuner and the SAW filter to be matched to achieve the optimum IF input level.

The AGC detector charges/discharges the AGC capacitor to the required voltage for setting of VIF and tuner gain in order to keep the video signal at a constant level. Therefore for negative video modulation the sync level and for positive video modulation the peak white level of the video signal is detected. In order to reduce the reaction time for positive modulation, where a very large time constant is needed, an additional level detector increases the discharging current of the AGC capacitor (fast mode) in the event of a decreasing VIF amplitude step. The additional level information is given by the black level detector voltage.

#### Frequency Phase Locked Loop detector (FPLL)

The VIF-amplifier output signal is fed into a frequency detector and into a phase detector via a limiting amplifier. During acquisition the frequency detector produces a DC current proportional to the frequency difference between the input and the VCO signal. After frequency lock-in the phase detector produces a DC current proportional to the phase difference between the VCO and the input signal. The DC current of either frequency detector or phase detector is converted into a DC voltage via the loop filter, which controls the VCO frequency. In the event of positive modulated signals the phase detector is gated by composite sync in order to avoid signal distortion for overmodulated VIF signals.

#### VCO, Travelling Wave Divider (TWD) and AFC

The VCO operates with a resonance circuit (with L and C in parallel) at double the PC frequency. The VCO is controlled by two integrated variable capacitors. The control voltage required to tune the VCO from its free-running frequency to actually double the PC frequency is generated by the frequency-phase detector (FPLL) and fed via the loop filter to the first variable capacitor. This control voltage is amplified and additionally converted into a current which represents the AFC output signal. The VCO centre frequency can be decreased (required for L accent standard) by activating an additional internal capacitor. This is achieved by using the L accent switch. In this event the second variable capacitor can be controlled by a variable resistor at the L accent switch for setting the VCO centre frequency to the required L accent value. At centre frequency the AFC output current is equal to zero.

The oscillator signal is divided-by-two with a TWD which generates two differential output signals with a 90 degree phase difference independent of the frequency.

## Multistandard VIF-PLL with QSS-IF and dual FM-PLL/AM demodulator

TDA9814T

### Video demodulator and amplifier

The video demodulator is realized by a multiplier which is designed for low distortion and large bandwidth. The vision IF input signal is multiplied with the 'in phase' signal of the travelling wave divider output. In the demodulator stage the video signal polarity can be switched in accordance with the TV standard.

The demodulator output signal is fed via an integrated low-pass filter for attenuation of the carrier harmonics to the video amplifier. The video amplifier is realized by an operational amplifier with internal feedback and high bandwidth. A low-pass filter is integrated to achieve an attenuation of the carrier harmonics for B/G and L standard. The standard dependent level shift in this stage delivers the same sync level for positive and negative modulation. The video output signal is 1 V (p-p) for nominal vision IF modulation.

### Video buffer

For an easy adaption of the sound traps an operational amplifier with internal feedback is used in the event of B/G and L standard. This amplifier is featured with a high bandwidth and 7 dB gain. The input impedance is adapted for operating in combination with ceramic sound traps. The output stage delivers a nominal 2 V (p-p) positive video signal. Noise clipping is provided.

### SIF amplifier and AGC

The sound IF amplifier consists of two AC-coupled differential amplifier stages. Each differential stage comprises a controlled feedback network provided by emitter degeneration.

The SIF AGC detector is related to the SIF input signals (average level of AM or FM carriers) and controls the SIF amplifier to provide a constant SIF signal to the AM demodulator and single reference QSS mixer. The SIF AGC reaction time is set to 'slow' for nominal video conditions. But with a decreasing VIF amplitude step the SIF AGC is set to 'fast' mode controlled by the VIF-AGC detector. In FM mode this reaction time is also set to 'fast' controlled by the standard switch.

### Single reference QSS mixer

The single reference QSS mixer is realized by a multiplier. The SIF amplifier output signal is fed to the single reference QSS mixer and converted to intercarrier frequency by the regenerated picture carrier (VCO). The mixer output signal is fed via a high-pass for attenuation of the video signal components to the output pin 17. With this system a high performance hi-fi stereo sound processing can be achieved.

### AM demodulator

The AM demodulator is realized by a multiplier. The modulated SIF amplifier output signal is multiplied in phase with the limited (AM is removed) SIF amplifier output signal. The demodulator output signal is fed via an integrated low-pass filter for attenuation of the carrier harmonics to the AF amplifier.

### FM-PLL demodulator

Each FM-PLL demodulator consists of a limiter, an FM-PLL and an AF amplifier. The limiter provides the amplification and limitation of the FM sound intercarrier signal before demodulation. The result is high sensitivity and AM suppression. The amplifier consists of 7 stages which are internally AC-coupled in order to minimize the DC offset and to save pins for DC decoupling.

The second limiter is extended with an additional level detector consisting of a rectifier and a comparator. By means of this the AF2 signal is set to mute and the PLL VCO is switched off, if the intercarrier signal at pin 14 is below 1 mV (RMS) in order to avoid false identification of a stereo decoder. Note that noise at pin 14 disables the mute state (at low SIF input signal), but this will not lead to false identification. This 'auto-mute' function can be disabled by connecting a 5.6 k $\Omega$  resistor from pin 14 to  $V_P$  (see Fig.13).

Furthermore the AF output signals can be muted by connecting a resistor between the limiter inputs pin 14 or pin 15 and ground.

## Multistandard VIF-PLL with QSS-IF and dual FM-PLL/AM demodulator

TDA9814T

The FM-PLL consists of an integrated relaxation oscillator, an integrated loop filter and a phase detector. The oscillator is locked to the FM intercarrier signal, output from the limiter. As a result of locking, the oscillator frequency tracks with the modulation of the input signal and the oscillator control voltage is superimposed by the AF voltage. The FM-PLL operates as an FM-demodulator.

The AF amplifier consists of two parts:

1. The AF preamplifier for FM sound is an operational amplifier with internal feedback, high gain and high common mode rejection. The AF voltage from the PLL demodulator, by principle a small output signal, is amplified by approximately 33 dB. The low-pass characteristic of the amplifier reduces the harmonics of the intercarrier signal at the sound output terminal. An additional DC control circuit is implemented to keep the DC level constant, independent of process spread.
2. The AF output amplifier (10 dB) provides the required output level by a rail-to-rail output stage. This amplifier makes use of an input selector for switching to AM/FM or mute state, controlled by the standard switching voltage and the mute switching voltage.

### Internal voltage stabilizer and $\frac{1}{2}V_P$ -reference

The bandgap circuit internally generates a voltage of approximately 1.25 V, independent of supply voltage and temperature. A voltage regulator circuit, connected to this voltage, produces a constant voltage of 3.6 V which is used as an internal reference voltage.

For all audio output signals the constant reference voltage cannot be used because large output signals are required. Therefore these signals refer to half the supply voltage to achieve a symmetrical headroom, especially for the rail-to-rail output stage. For ripple and noise attenuation the  $\frac{1}{2}V_P$  voltage has to be filtered via a low-pass filter by using an external capacitor together with an integrated resistor ( $f_g = 5$  Hz). For a fast setting to  $\frac{1}{2}V_P$  an internal start-up circuit is added.

### LIMITING VALUES

In accordance with the Absolute Maximum Rating System (IEC 134).

SYMBOL	PARAMETER	CONDITIONS	MIN.	MAX.	UNIT
$V_P$	supply voltage (pin 26)	maximum chip temperature of 125 °C; note 1	0	5.5	V
$V_n$	voltage at pins 1 to 7, 9 to 16, 19, 20 and 23 to 28		0	$V_P$	V
$t_{s(max)}$	maximum short-circuit time		–	10	s
$V_{16}$	tuner AGC output voltage		0	13.2	V
$T_{stg}$	storage temperature		–25	+150	°C
$T_{amb}$	operating ambient temperature		–20	+70	°C
$V_{es}$	electrostatic handling voltage	note 2	–300	+300	V

### Notes

1.  $I_P = 125$  mA;  $T_{amb} = 70$  °C;  $R_{th(j-a)} = 80$  K/W.
2. Machine model class B ( $L = 2.5$   $\mu$ H).

### THERMAL CHARACTERISTICS

SYMBOL	PARAMETER	CONDITIONS	VALUE	UNIT
$R_{th(j-a)}$	thermal resistance from junction to ambient	in free air	80	K/W



# Multistandard VIF-PLL with QSS-IF and dual FM-PLL/AM demodulator

TDA9814T

## CHARACTERISTICS

$V_P = 5\text{ V}$ ;  $T_{\text{amb}} = 25\text{ °C}$ ; see Table 1 for input frequencies and carrier ratios; input level  $V_{i\text{IF}1,2} = 10\text{ mV}$  RMS value (sync-level for B/G, peak white level for L); video modulation DSB; residual carrier B/G: 10%; L = 3%; video signal in accordance with "CCIR, line 17"; measurements taken in Fig. 13; unless otherwise specified.

SYMBOL	PARAMETER	CONDITIONS	MIN.	TYP.	MAX.	UNIT
<b>Supply (pin 26)</b>						
$V_P$	supply voltage	note 1	4.5	5	5.5	V
$I_P$	supply current		93	109	125	mA
<b>Vision IF amplifier (pins 1 and 2)</b>						
$V_{i\text{VIF(rms)}}$	input signal voltage sensitivity (RMS value)	B/G standard; -1 dB video at output	-	60	100	$\mu\text{V}$
$V_{i\text{max(rms)}}$	maximum input signal voltage (RMS value)	B/G standard; +1 dB video at output	120	200	-	mV
$\Delta V_{o(\text{int})}$	internal IF amplitude difference between picture and sound carrier	within AGC range; B/G standard; $\Delta f = 5.5\text{ MHz}$	-	0.7	1	dB
$G_{\text{IFcr}}$	IF gain control range	see Fig.3	65	70	-	dB
$R_{i(\text{diff})}$	differential input resistance	note 2	1.7	2.2	2.7	$\text{k}\Omega$
$C_{i(\text{diff})}$	differential input capacitance	note 2	1.2	1.7	2.5	pF
$V_{1,2}$	DC input voltage	note 2	-	3.4	-	V
<b>True synchronous video demodulator; note 3</b>						
$f_{\text{VCO(max)}}$	maximum oscillator frequency for carrier regeneration	$f = 2f_{\text{PC}}$	125	130	-	MHz
$\Delta f_{\text{osc}}/\Delta T$	oscillator drift as a function of temperature	oscillator is free-running; $I_{\text{AFC}} = 0$ ; note 4	-	-	$\pm 20 \times 10^{-6}$	$\text{K}^{-1}$
$V_{o\text{ref(rms)}}$	oscillator voltage swing at pins 21 and 22 (RMS value)		70	100	130	mV
$f_{\text{PC CR}}$	picture carrier capture range	B/G and L standard	$\pm 1.4$	$\pm 1.8$	-	MHz
		L accent standard; $f_{\text{PC}} = 33.9\text{ MHz}$ ; $R_g = 5.6\text{ k}\Omega$	$\pm 0.9$	$\pm 1.2$	-	MHz
$Q_{f_{\text{PC(tr)}}$	picture carrier frequency (free-running) accuracy	L accent standard; $f_{\text{PC}} = 33.9\text{ MHz}$ ; $R_g = 5.6\text{ k}\Omega$	-	$\pm 200$	$\pm 400$	kHz
$f_{\text{PC(alg)CR}}$	L accent alignment frequency range	$I_{\text{AFC}} = 0$	$\pm 400$	$\pm 600$	-	kHz
$t_{\text{acq}}$	acquisition time	BL = 75 kHz; note 5	-	-	30	ms
$V_{i\text{VIF(rms)}}$	VIF input signal voltage sensitivity for PLL to be locked (RMS value; pins 1 and 2)	maximum IF gain; note 6	-	30	70	$\mu\text{V}$

**Multistandard VIF-PLL with QSS-IF  
and dual FM-PLL/AM demodulator**

TDA9814T

SYMBOL	PARAMETER	CONDITIONS	MIN.	TYP.	MAX.	UNIT
<b>Composite video amplifier (pin 18; sound carrier off)</b>						
$V_{o\text{ video(p-p)}}$	output signal voltage (peak-to-peak value)	see Fig.8	0.88	1.0	1.12	V
V/S	ratio between video (black-to-white) and sync level		1.9	2.33	3.0	–
$\Delta V_{o(\text{video})}$	output signal voltage difference	difference between B/G and L standard	–	–	$\pm 12$	%
$V_{18(\text{sync})}$	sync voltage level	B/G and L standard	–	1.5	–	V
$V_{18(\text{clu})}$	upper video clipping voltage level		$V_P - 1.1$	$V_P - 1$	–	V
$V_{18(\text{cll})}$	lower video clipping voltage level		–	0.7	0.9	V
$R_{o,18}$	output resistance	note 2	–	–	10	$\Omega$
$I_{\text{int } 18}$	internal DC bias current for emitter-follower		2.2	3.0	–	mA
$I_{18\text{ max(sink)}}$	maximum AC and DC output sink current		1.6	–	–	mA
$I_{18\text{ max(source)}}$	maximum AC and DC output source current		2.9	–	–	mA
$B_{-1}$	–1 dB video bandwidth	B/G and L standard; $C_L < 50\text{ pF}$ ; $R_L > 1\text{ k}\Omega$ ; AC load	5	6	–	MHz
$B_{-3}$	–3 dB video bandwidth	B/G and L standard; $C_L < 50\text{ pF}$ ; $R_L > 1\text{ k}\Omega$ ; AC load	7	8	–	MHz
$\alpha_{H(\text{sup})}$	suppression of video signal harmonics	$C_L < 50\text{ pF}$ ; $R_L > 1\text{ k}\Omega$ ; AC load; note 7a	35	40	–	dB
PSRR	power supply ripple rejection at pin 18	video signal; grey level; see Fig.11 B/G standard L standard	32 26	35 30	– –	dB dB
<b>CVBS buffer amplifier (only) and noise clipper (pins 8 and 19)</b>						
$R_{i,19}$	input resistance	note 2	2.6	3.3	4.0	k $\Omega$
$C_{i,19}$	input capacitance	note 2	1.4	2	3.0	pF
$V_{i,19}$	DC input voltage		1.4	1.7	2.0	V
$G_v$	voltage gain	B/G and L standard; note 8	6.5	7	7.5	dB
$V_{8(\text{clu})}$	upper video clipping voltage level		3.9	4.0	–	V
$V_{8(\text{cll})}$	lower video clipping voltage level		–	1.0	1.1	V
$R_{o,8}$	output resistance	note 2	–	–	10	$\Omega$
$I_{\text{int } 8}$	DC internal bias current for emitter-follower		2.0	2.5	–	mA

# Multistandard VIF-PLL with QSS-IF and dual FM-PLL/AM demodulator

TDA9814T

SYMBOL	PARAMETER	CONDITIONS	MIN.	TYP.	MAX.	UNIT
$I_{o,8 \max(\text{sink})}$	maximum AC and DC output sink current		1.4	–	–	mA
$I_{o,10 \max(\text{source})}$	maximum AC and DC output source current		2.4	–	–	mA
$B_{-1}$	–1 dB video bandwidth	B/G and L standard; $C_L < 20 \text{ pF}$ ; $R_L > 1 \text{ k}\Omega$ ; AC load	8.4	11	–	MHz
$B_{-3}$	–3 dB video bandwidth	B/G and L standard; $C_L < 20 \text{ pF}$ ; $R_L > 1 \text{ k}\Omega$ ; AC load	11	14	–	MHz
<b>Measurements from IF input to CVBS output (pin 8; 330 <math>\Omega</math> between pins 18 and 19, sound carrier off)</b>						
$V_o \text{ CVBS(p-p)}$	CVBS output signal voltage on pin 8 (peak-to-peak value)	note 8	1.7	2.0	2.3	V
$V_o \text{ CVBS(sync)}$	sync voltage level	B/G standard	–	1.35	–	V
		L standard	–	1.35	–	V
$\Delta V_o$	deviation of CVBS output signal voltage at B/G	50 dB gain control	–	–	0.5	dB
		30 dB gain control	–	–	0.1	dB
$\Delta V_o(\text{bl/B/G})$	black level tilt in B/G standard	gain variation; note 9	–	–	1	%
$\Delta V_o(\text{bl/L})$	black level tilt for worst case in L standard	picture carrier modulated by test line (VITS) only; gain variation; note 9	–	–	1.9	%
$G_{\text{diff}}$	differential gain	"CCIR, line 330"	–	2	5	%
$\Phi_{\text{diff}}$	differential phase	"CCIR, line 330"	–	1	2	deg
$B_{-1}$	–1 dB video bandwidth	$C_L < 20 \text{ pF}$ ; $R_L > 1 \text{ k}\Omega$ ; AC load; B/G and L standard	5	6	–	MHz
$B_{-3}$	–3 dB video bandwidth	$C_L < 20 \text{ pF}$ ; $R_L > 1 \text{ k}\Omega$ ; AC load; B/G and L standard	7	8	–	MHz
S/N (W)	weighted signal-to-noise ratio	see Fig.5 and note 10	56	60	–	dB
S/N	unweighted signal-to-noise ratio	see Fig.5 and note 10	49	53	–	dB
$IM\alpha_{1,1}$	intermodulation attenuation at 'blue'	$f = 1.1 \text{ MHz}$ ; see Fig.6 and note 11	58	64	–	dB
	intermodulation attenuation at 'yellow'	$f = 1.1 \text{ MHz}$ ; see Fig.6 and note 11	60	66	–	dB
$IM\alpha_{3,3}$	intermodulation attenuation at 'blue'	$f = 3.3 \text{ MHz}$ ; see Fig.6 and note 11	58	64	–	dB
	intermodulation attenuation at 'yellow'	$f = 3.3 \text{ MHz}$ ; see Fig.6 and note 11	59	65	–	dB
$\alpha_{\text{pc(rms)}}$	residual picture carrier (RMS value)	fundamental wave and harmonics; B/G and L standard	–	2	5	mV

# Multistandard VIF-PLL with QSS-IF and dual FM-PLL/AM demodulator

TDA9814T

SYMBOL	PARAMETER	CONDITIONS	MIN.	TYP.	MAX.	UNIT
$\Delta f_{\text{unwanted(p-p)}}$	robustness for unwanted frequency deviation of picture carrier (peak-to-peak value)	L standard; residual carrier: 3%; serration pulses: 50%; note 2	–	–	12	kHz
$\Delta\phi$	robustness for modulator imbalance	L standard; residual carrier: 0%; serration pulses: 50%; note 2	–	–	3	%
$\alpha_{H(\text{sup})}$	suppression of video signal harmonics	note 7a	35	40	–	dB
$\alpha_{H(\text{spur})}$	spurious elements	note 7b	40	–	–	dB
PSRR	power supply ripple rejection at pin 8	video signal; grey level; see Fig.11 B/G standard L standard	25 20	28 23	– –	dB dB
<b>VIF-AGC detector (pin 25)</b>						
$I_{25}$	charging current	B/G and L standard; note 9	0.75	1	1.25	mA
	additional charging current	L standard in event of missing VITS pulses and no white video content	1.9	2.5	3.1	$\mu\text{A}$
	discharging current	B/G standard	15	20	25	$\mu\text{A}$
		normal mode L standard	225	300	375	nA
$t_{\text{resp}}$	AGC response to an increasing VIF step	B/G and L standard; note 12	–	0.05	0.1	ms/dB
		B/G standard	–	2.2	3.5	ms/dB
	AGC response to a decreasing VIF step	fast mode L standard	–	1.1	1.8	ms/dB
		normal mode L standard; note 12	–	150	240	ms/dB
$\Delta\text{IF}$	VIF amplitude step for activating fast AGC mode	L standard	–2	–6	–10	dB
$V_{3(\text{th})}$	threshold voltage level additional charging current	see Fig.8	–	–	–	–
		L standard	–	1.95	–	V
		L standard; fast mode L	–	1.65	–	V
<b>Tuner AGC (pin 16)</b>						
$V_{i(\text{rms})}$	IF input signal voltage for minimum starting point of tuner takeover (RMS value)	input at pins 1 and 2; $R_{\text{TOP}} = 22 \text{ k}\Omega$ ; $I_{16} = 0.4 \text{ mA}$	–	2	5	mV
	IF input signal voltage for maximum starting point of tuner takeover (RMS value)	input at pins 1 and 2; $R_{\text{TOP}} = 0 \text{ }\Omega$ ; $I_{16} = 0.4 \text{ mA}$	50	100	–	mV
$V_{o,16}$	permissible output voltage	from external source; note 2	–	–	13.2	V
$V_{\text{sat},16}$	saturation voltage	$I_{16} = 1.5 \text{ mA}$	–	–	0.2	V

Multistandard VIF-PLL with QSS-IF  
and dual FM-PLL/AM demodulator

TDA9814T

SYMBOL	PARAMETER	CONDITIONS	MIN.	TYP.	MAX.	UNIT
$\Delta V_{TOP,16}/\Delta T$	variation of takeover point by temperature	$I_{16} = 0.4 \text{ mA}$	–	0.03	0.07	dB/K
$I_{16(\text{sink})}$	sink current	see Fig.3 no tuner gain reduction; $V_{16} = 13.2 \text{ V}$	–	–	1	$\mu\text{A}$
		maximum tuner gain reduction	1.5	2	2.6	mA
$\Delta G_{IF}$	IF slip by automatic gain control	tuner gain current from 20 to 80%	–	6	8	dB
<b>AFC circuit (pin 20); see Fig.7 and note 13</b>						
S	control steepness $\Delta I_{20}/\Delta f$	note 14	0.5	0.75	1.0	$\mu\text{A}/\text{kHz}$
$\Delta f_{IF}/\Delta T$	frequency variation by temperature	$I_{AFC} = 0$ ; note 5	–	–	$\pm 20 \times 10^{-6}$	$\text{K}^{-1}$
$V_{o,20}$	output voltage upper limit	see Fig.7 without external components	$V_P - 0.6$	$V_P - 0.3$	–	V
	output voltage lower limit		–	0.3	0.6	V
$I_{o,20(\text{source})}$	output source current	see Fig.7	150	200	250	$\mu\text{A}$
$I_{o,20(\text{sink})}$	output sink current		150	200	250	$\mu\text{A}$
$\Delta I_{20(\text{p-p})}$	residual video modulation current (peak-to-peak value)	B/G and L standard	–	20	30	$\mu\text{A}$
<b>Sound IF amplifier (pins 27 and 28)</b>						
$V_{i \text{ SIF}(\text{rms})}$	input signal voltage sensitivity (RMS value)	FM mode; –3 dB at intercarrier output pin 17	–	30	70	$\mu\text{V}$
		AM mode; –3 dB at AF output pin 10	–	70	100	$\mu\text{V}$
$V_{i \text{ max}(\text{rms})}$	maximum input signal voltage (RMS value)	FM mode; +1 dB at intercarrier output pin 17	50	70	–	mV
		AM mode; +1 dB at AF output pin 10	80	140	–	mV
$G_{\text{SIFcr}}$	SIF gain control range	FM and AM mode; see Fig.4	60	67	–	dB
$R_{i(\text{diff})}$	differential input resistance	note 2	1.7	2.2	2.7	k $\Omega$
$C_{i(\text{diff})}$	differential input capacitance	note 2	1.2	1.7	2.5	pF
$V_{I(27,28)}$	DC input voltage		–	3.4	–	V
$\alpha_{\text{ct}(\text{SIF,VIF})}$	crosstalk attenuation between SIF and VIF input	between pins 1 and 2 and pins 27 and 28; note 15	50	–	–	dB
<b>SIF-AGC detector (pin 6)</b>						
$I_6$	charging current	FM mode	8	12	16	$\mu\text{A}$
		AM mode	0.8	1.2	1.6	$\mu\text{A}$
	discharging current	FM mode	8	12	16	$\mu\text{A}$
		normal mode AM	1	1.4	1.8	$\mu\text{A}$
		fast mode AM	60	85	110	$\mu\text{A}$

Multistandard VIF-PLL with QSS-IF  
and dual FM-PLL/AM demodulator

TDA9814T

SYMBOL	PARAMETER	CONDITIONS	MIN.	TYP.	MAX.	UNIT
<b>Single reference QSS intercarrier mixer (B/G standard; pin 17)</b>						
$V_{o(rms)}$	IF intercarrier level (RMS value)	SC <sub>1</sub> ; sound carrier 2 off	75	100	125	mV
$B_{-3}$	-3 dB intercarrier bandwidth	upper limit	7.5	9	–	MHz
$\alpha_{SC(rms)}$	residual sound carrier (RMS value)	fundamental wave and harmonics	–	2	–	mV
$R_{o,17}$	output resistance	note 2	–	–	25	$\Omega$
$V_{O,17}$	DC output voltage		–	2.0	–	V
$I_{int\ 17}$	DC internal bias current for emitter-follower		1.5	1.9	–	mA
$I_{17\ max(sink)}$	maximum AC and DC output sink current		1.1	1.5	–	mA
$I_{17\ max(source)}$	maximum AC and DC output source current		3.0	3.5	–	mA
<b>Limiter amplifier 1 (pin 15); note 16</b>						
$V_{i\ FM(rms)}$	input signal voltage for lock-in (RMS value)		–	–	100	$\mu$ V
$V_{i\ FM(rms)}$	input signal voltage (RMS value)	$\frac{S+N}{N} = 40\ dB$	–	300	400	$\mu$ V
	allowed input signal voltage (RMS value)		200	–	–	mV
$R_{i,15}$	input resistance	note 2	480	600	720	$\Omega$
$V_{I,15}$	DC input voltage		–	2.8	–	V
<b>Limiter amplifier 2 (pin 14); note 16</b>						
$V_{i\ FM(rms)}$	input signal voltage for lock-in (RMS value)		–	–	100	$\mu$ V
$V_{i\ FM(rms)}$	input signal voltage (RMS value)	$\frac{S+N}{N} = 40\ dB$ PLL1 has to be in locked mode; auto mute off	–	300	400	$\mu$ V
	allowed input signal voltage (RMS value)		200	–	–	mV
	input signal voltage for no auto mute; PLL enabled (RMS value)		0.7	1	1.5	mV
$HYS_{14}$	hysteresis of level detector for auto mute		–3	–6	–8	dB
$R_{i,14}$	input resistance	note 2	480	600	720	$\Omega$
$V_{I,14}$	DC input voltage		–	2.0	–	V

# Multistandard VIF-PLL with QSS-IF and dual FM-PLL/AM demodulator

TDA9814T

SYMBOL	PARAMETER	CONDITIONS	MIN.	TYP.	MAX.	UNIT
<b>FM-PLL demodulator</b>						
$f_{i\text{ FM(catch)}}$	catching range of PLL	upper limit	7.0	–	–	MHz
		lower limit	–	–	4.0	MHz
$f_{i\text{ FM(hold)}}$	holding range of PLL	upper limit	8.0	–	–	MHz
		lower limit	–	–	3.5	MHz
$t_{\text{acq}}$	acquisition time		–	–	4	$\mu\text{s}$
<b>FM operation (B/G standard; pins 10 and 11); notes 16 and 16a</b>						
$V_{o\text{ AF10,11(rms)}}$	AF output signal voltage (RMS value)	27 kHz (54% FM deviation); see Fig.13 and note 17 $R_x = R_y = 470\ \Omega$	200	250	300	mV
		$R_x = R_y = 0\ \Omega$	400	500	600	mV
$V_{o\text{ AF10,11(cl)}}$	AF output clipping signal voltage level	THD < 1.5%	1.3	1.4	–	V
$\Delta f_{\text{AF}}$	frequency deviation	THD < 1.5%; note 17	–	–	53	kHz
$\Delta V_o/\Delta T$	temperature drift of AF output signal voltage		–	$3 \times 10^{-3}$	$7 \times 10^{-3}$	dB/K
$V_{12,13}$	DC voltage at decoupling capacitor	voltage dependent on VCO frequency; note 18	1.2	–	3.0	V
$R_{10,11}$	output resistance	note 2	–	–	100	$\Omega$
$V_{10,11}$	DC output voltage	tracked with supply voltage	–	$\frac{1}{2}V_P$	–	V
$I_{10,11\text{max(sink)}}$	maximum AC and DC output sink current		–	–	1.1	mA
$I_{10,11\text{max(source)}}$	maximum AC and DC output source current		–	–	1.1	mA
$B_{-3}$	–3 dB video bandwidth		100	125	–	kHz
THD	total harmonic distortion		–	0.15	0.5	%
S/N (W)	weighted signal-to-noise ratio	FM-PLL only; with 50 $\mu\text{s}$ de-emphasis; 27 kHz (54% FM deviation); "CCIR 468-4"	55	60	–	dB
$\alpha_{\text{SC(rms)}}$	residual sound carrier (RMS value)	fundamental wave and harmonics	–	–	75	mV
$\alpha_{\text{AM}}$	AM suppression	50 $\mu\text{s}$ de-emphasis; AM: $f = 1\ \text{kHz}$ ; $m = 0.3$ refer to 27 kHz (54% FM deviation)	46	50	–	dB
$\alpha_{10,11}$	mute attenuation of AF signal	B/G and L standard	70	80	–	dB
$\Delta V_{10,11}$	DC jump voltage of AF output terminals for switching AF output to mute state and vice versa	FM-PLLs in lock mode; note 19	–	$\pm 50$	$\pm 150$	mV
PSRR	power supply ripple rejection at pins 10 and 11	$R_x = R_y = 0\ \Omega$ ; see Figs 11 and 13	22	28	–	dB

**Multistandard VIF-PLL with QSS-IF  
and dual FM-PLL/AM demodulator**
**TDA9814T**

SYMBOL	PARAMETER	CONDITIONS	MIN.	TYP.	MAX.	UNIT
<b>Single reference QSS AF performance for FM operation (B/G standard);</b> (notes 20, 21 and 22; see Table 1)						
S/N (W)	weighted signal-to-noise ratio (SC <sub>1</sub> /SC <sub>2</sub> )	PC/SC <sub>1</sub> ratio at pins 1 and 2; 27 kHz (54% FM deviation); "CCIR 468-4"	40	–	–	dB
		black picture	53/48	58/55	–	dB
		white picture	50/46	55/52	–	dB
		6 kHz sine wave; black-to-white modulation	42/40	48/46	–	dB
		250 kHz square wave; black-to-white modulation; see note 2 in Fig. 14	45/42	53/50	–	dB
		sound carrier subharmonics; f = 2.75 MHz ±3 kHz	45/44	51/50	–	dB
S/N (W)	weighted signal-to-noise ratio	sound carrier subharmonics; f = 2.87 MHz ±3 kHz	46/45	52/51	–	dB
<b>AM operation (L standard; pin 10);</b> note 23						
V <sub>o AF10(rms)</sub>	AF output signal voltage (RMS value)	54% modulation	400	500	600	mV
THD	total harmonic distortion	54% modulation; see Fig. 10	–	0.5	1.0	%
B <sub>-3</sub>	-3 dB AF bandwidth		100	125	–	kHz
S/N (W)	weighted signal-to-noise ratio	"CCIR 468-4"; see Fig. 9	47	53	–	dB
V <sub>10</sub>	DC potential voltage	tracked with supply voltage	–	½V <sub>P</sub>	–	V
PSRR	power supply ripple rejection	see Fig. 11	22	25	–	dB
<b>Standard switch (pin 7);</b> see also Table 2						
V <sub>7</sub>	DC potential voltage for preferred settings					
	input voltage for negative standard	B/G standard; note 24	2.8	–	V <sub>P</sub>	V
	input voltage for negative standard	negative AGC <b>off</b>	1.3	–	2.3	V
V <sub>7</sub>	input voltage for positive standard	L standard	0	–	0.8	V
I <sub>IL</sub>	LOW-level input current	V <sub>7</sub> = 0 V	190	250	310	µA



Multistandard VIF-PLL with QSS-IF  
and dual FM-PLL/AM demodulator

TDA9814T

SYMBOL	PARAMETER	CONDITIONS	MIN.	TYP.	MAX.	UNIT
<b>L accent switch (pin 9)</b>						
V <sub>g</sub>	DC potential voltage for L standard VCO frequency switching	note 24	2.8	–	V <sub>P</sub>	V
	L standard					
	L accent standard and alignment		0	–	2.0	V
I <sub>IL</sub>	LOW-level input current	V <sub>g</sub> = 0 V	150	200	250	μA

**Notes to the characteristics**

- Values of video and sound parameters are decreased at V<sub>P</sub> = 4.5 V.
- This parameter is not tested during production and is only given as application information for designing the television receiver.
- Loop bandwidth BL = 75 kHz (natural frequency f<sub>n</sub> = 11 kHz; damping factor d ≈ 3.5; calculated with sync level within gain control range). Resonance circuit of VCO: Q<sub>0</sub> > 50; C<sub>ext</sub> = 8.2 pF ± 0.25 pF; C<sub>int</sub> ≈ 8.5 pF (loop voltage approximately 2.7 V).
- Temperature coefficient of external LC-circuit is equal to zero.
- V<sub>iIF</sub> = 10 mV RMS; Δf = 1 MHz (VCO frequency offset related to picture carrier frequency); white picture video modulation.
- V<sub>iIF</sub> signal for nominal video signal.
- Measurements taken with SAW filter G3962 (sound carrier suppression: 40 dB); loop bandwidth BL = 75 kHz:
  - Modulation VSB; sound carrier **off**; f<sub>video</sub> > 0.5 MHz.
  - Sound carrier **on**; SIF SAW filter L9453; f<sub>video</sub> = 10 kHz to 10 MHz.
- The 7 dB buffer gain accounts for 1 dB loss in the sound trap. Buffer output signal is typical 2 V (p-p), in event of CVBS video amplifier output typical 1 V (p-p). If no sound trap is applied a 330 Ω resistor must be connected from output to input (from pin 18 to pin 19).
- The leakage current of the AGC capacitor should not exceed 1 μA at B/G standard respectively 10 nA current at L standard. Larger currents will increase the tilt.
- S/N is the ratio of black-to-white amplitude to the black level noise voltage (RMS value, pin 8). B = 5 MHz weighted in accordance with "CCIR 567".
- The intermodulation figures are defined:
 
$$\alpha_{1,1} = 20 \log \left( \frac{V_0 \text{ at } 4.4 \text{ MHz}}{V_0 \text{ at } 1.1 \text{ MHz}} \right) + 3.6 \text{ dB}; \alpha_{1,1} \text{ value at } 1.1 \text{ MHz referenced to black/white signal};$$

$$\alpha_{3,3} = 20 \log \left( \frac{V_0 \text{ at } 4.4 \text{ MHz}}{V_0 \text{ at } 3.3 \text{ MHz}} \right); \alpha_{3,3} \text{ value at } 3.3 \text{ MHz referenced to colour carrier}.$$
- Response speed valid for a VIF input level range of 200 μV up to 70 mV.
- To match the AFC output signal to different tuning systems a current source output is provided. The test circuit is given in Fig.7. The AFC-steepness can be changed by the resistors at pin 20.
- Depending on the ratio ΔC/C<sub>0</sub> of the LC resonant circuit of VCO (Q<sub>0</sub> > 50; see note 3; C<sub>0</sub> = C<sub>int</sub> + C<sub>ext</sub>).
- Source impedance: 2.3 kΩ in parallel to 12 pF (SAW filter); f<sub>iF</sub> = 38.9 MHz.

## Multistandard VIF-PLL with QSS-IF and dual FM-PLL/AM demodulator

TDA9814T

16. Input level for second IF from an external generator with 50  $\Omega$  source impedance. AC-coupled with 10 nF capacitor,  $f_{\text{mod}} = 1$  kHz, 27 kHz (54% FM deviation) of audio references. A VIF/SIF input signal is not permitted. Pins 6 and 25 have to be connected to positive supply voltage for minimum IF gain. S/N and THD measurements are taken at 50  $\mu$ s de-emphasis. The not tested FM-PLL has to be locked to an unmodulated carrier.
- a) Second IF input level 10 mV RMS.
17. Measured with an FM deviation of 27 kHz the typical AF output signal is 500 mV RMS ( $R_x = R_y = 0 \Omega$ ; see Fig. 13). By using  $R_x = R_y = 470 \Omega$  the AF output signal is attenuated by 6 dB (250 mV RMS) and adapted to the stereo decoder family TDA9840. For handling an FM deviation of more than 53 kHz the AF output signal has to be reduced by using  $R_x$  and  $R_y$  in order to avoid clipping (THD < 1.5%). For an FM deviation up to 100 kHz an attenuation of 6 dB is recommended with  $R_x = R_y = 470 \Omega$ .
18. The leakage current of the decoupling capacitor (2.2  $\mu$ F) should not exceed 1  $\mu$ A.
19. In the event of activated auto mute state the second FM-PLL oscillator is switched off, if the input signal at pin 14 is missing or too weak (see Fig. 13). In the event of switching the second FM-PLL oscillator on by the auto mute stage an increased DC jump is the consequence. Note, that noise at pin 14 disables the mute state (at low SIF input signal), but this will not lead to false identification of the used stereo decoder family TDA9840.
20. For all S/N measurements the used vision IF modulator has to meet the following specifications:
- a) Incidental phase modulation for black-to-white jump less than 0.5 degrees.
- b) QSS AF performance, measured with the television-demodulator AMF2 (audio output, weighted S/N ratio) better than 60 dB (deviation 27 kHz) for 6 kHz sine wave black-to-white video modulation.
- c) Picture-to-sound carrier ratio; PC/SC<sub>1</sub> = 13 dB (transmitter).
21. Measurements taken with SAW filter G3962 (Siemens) for vision IF (suppressed sound carrier) and G9350 (Siemens) for sound IF (suppressed picture carrier). Input level  $V_{\text{I SIF}} = 10$  mV RMS, 27 kHz (54% FM deviation).
22. The PC/SC ratio at pins 1 and 2 is calculated as the addition of TV transmitter PC/SC ratio and SAW filter PC/SC ratio. This PC/SC ratio is necessary to achieve the S/N(W) values as noted. A different PC/SC ratio will change these values.
23. Measurements taken with SAW filter L9453 (Siemens) for AM sound IF (suppressed picture carrier).
24. The input voltage has to be  $V_i > 2.8$  V or open-circuit.

**Table 1** Input frequencies and carrier ratios

DESCRIPTION	SYMBOL	B/G STANDARD	L STANDARD	L ACCENT STANDARD	UNIT
Picture carrier	$f_{\text{PC}}$	38.9	38.9	33.9	MHz
Sound carrier	$f_{\text{SC1}}$	33.4	32.4	40.4	MHz
	$f_{\text{SC2}}$	33.158	–	–	MHz
Picture-to-sound carrier ratio	SC <sub>1</sub>	13	10	10	dB
	SC <sub>2</sub>	20	–	–	dB

**Table 2** Switch logic

STANDARD SWITCH (PIN 7)	SELECTED STANDARD	VIDEO POLARITY	FM-PLL		AF-AMPLIFIER	
			1	2	1	2
2.8 V to $V_p$	B/G	negative	on	on	FM	FM
1.3 to 2.3 V	B/G, with external VIF-AGC	negative	on	on	FM	FM
0 to 0.8 V	L	positive	off	off	AM	mute

Multistandard VIF-PLL with QSS-IF  
and dual FM-PLL/AM demodulator

TDA9814T

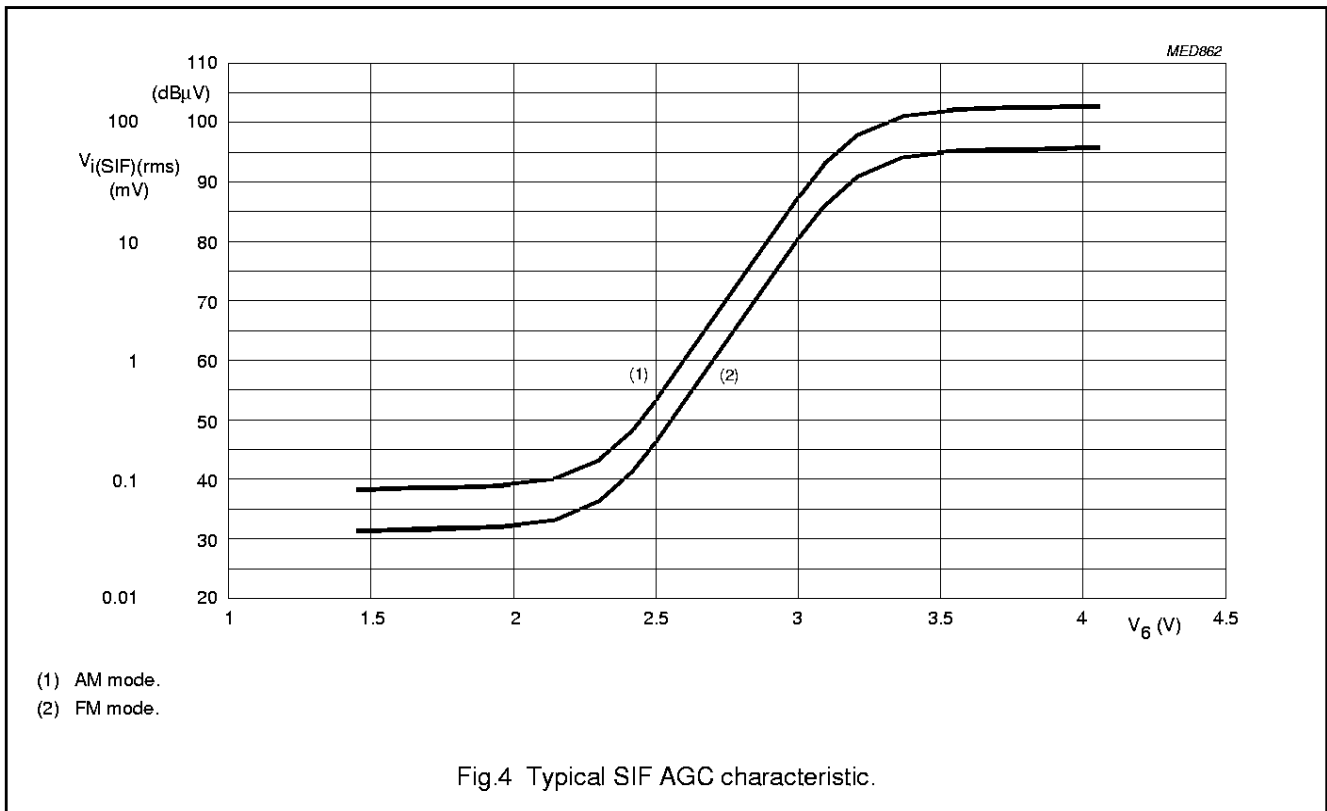
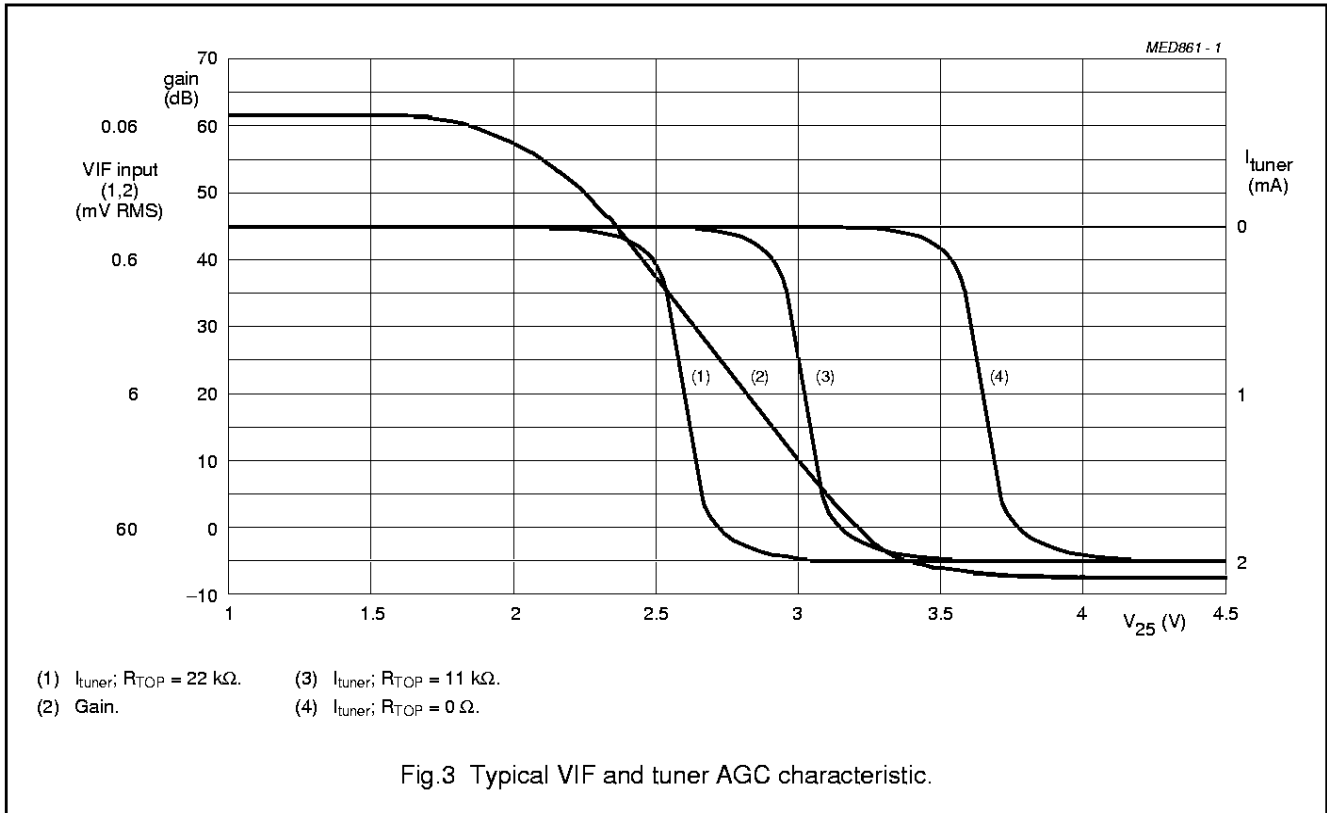

Multistandard VIF-PLL with QSS-IF  
and dual FM-PLL/AM demodulator

TDA9814T

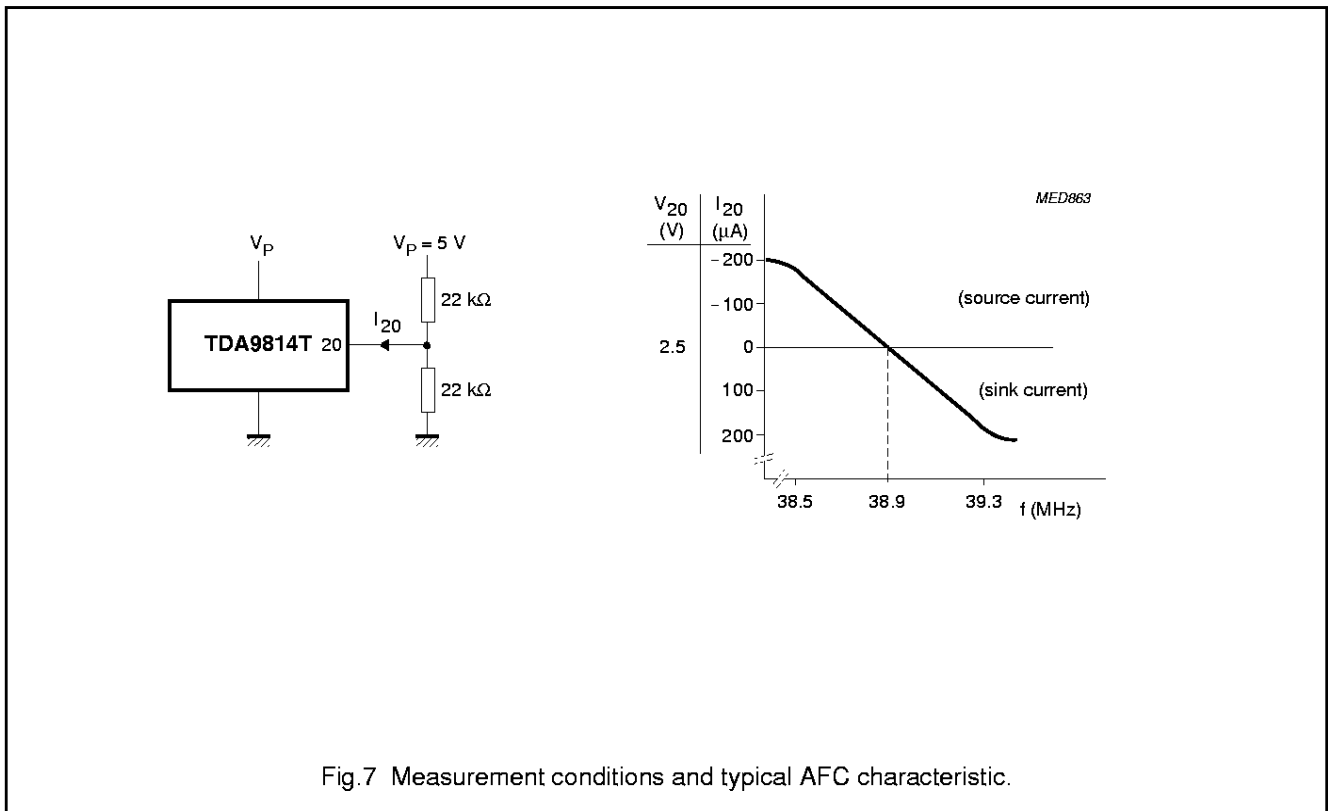
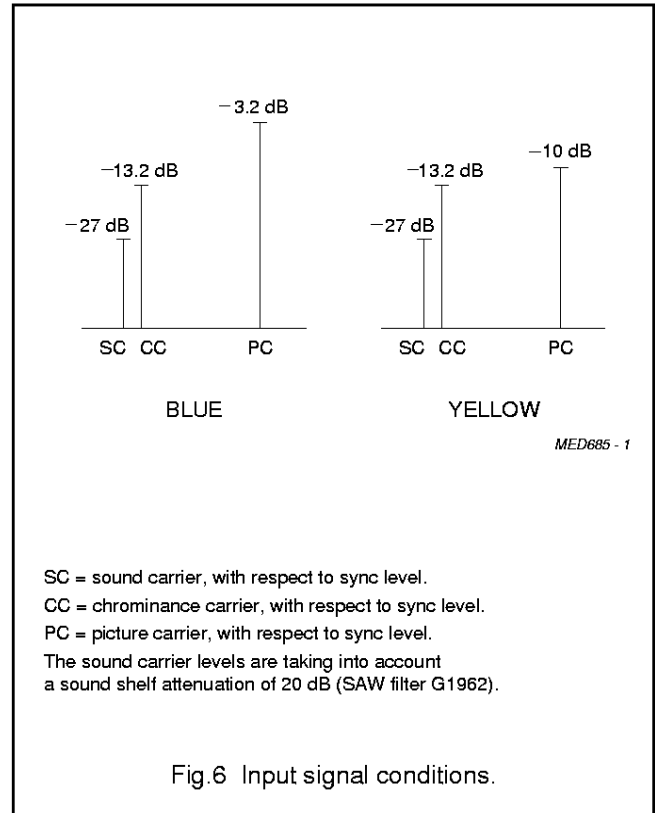
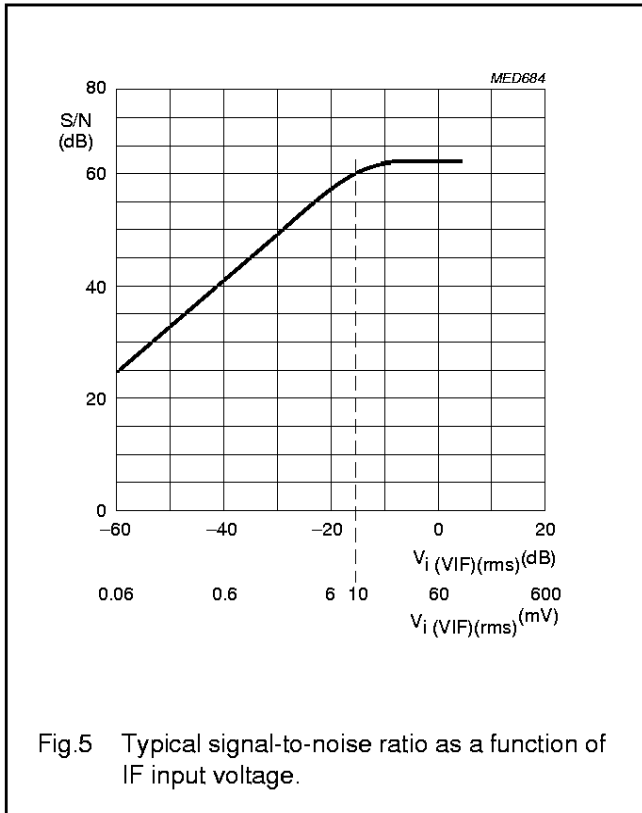

# Multistandard VIF-PLL with QSS-IF and dual FM-PLL/AM demodulator

TDA9814T

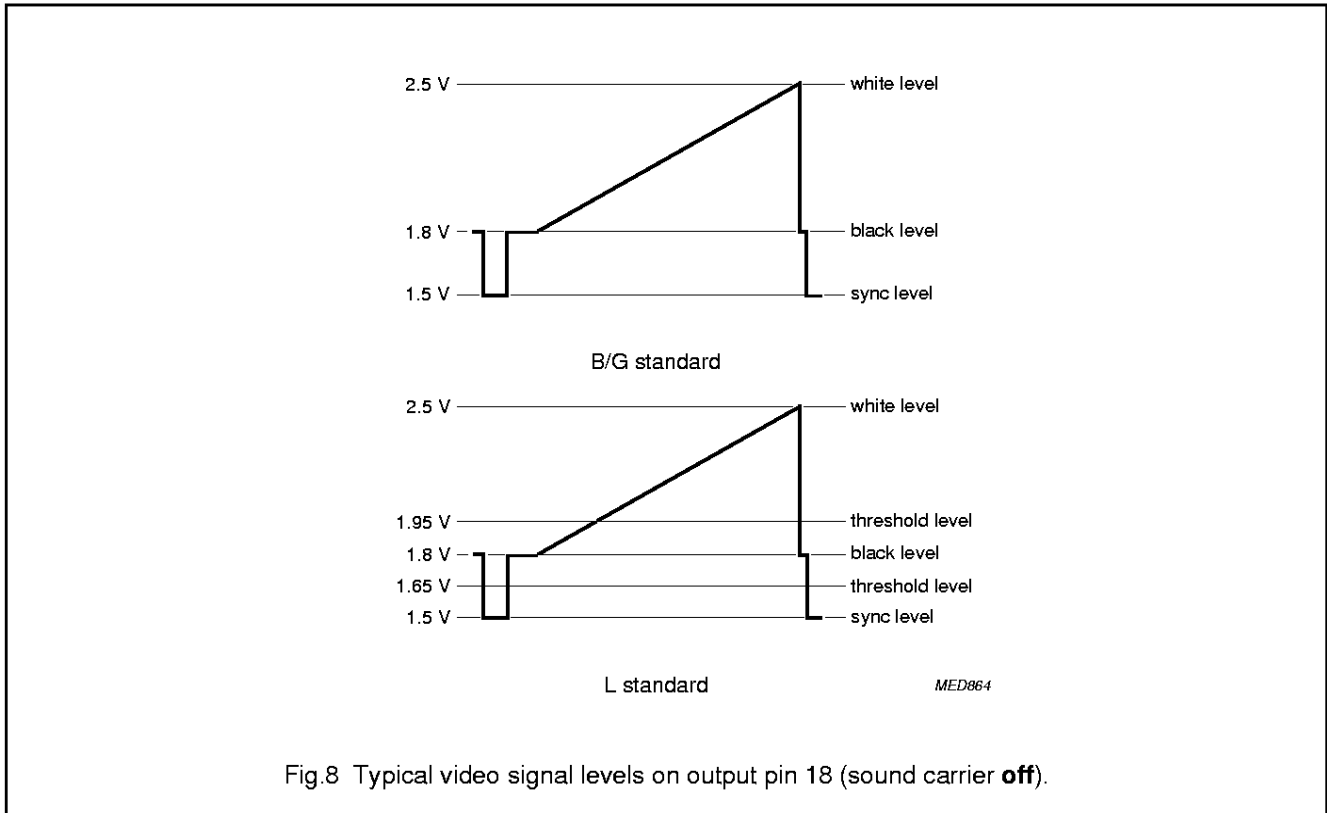

Fig.8 Typical video signal levels on output pin 18 (sound carrier **off**).

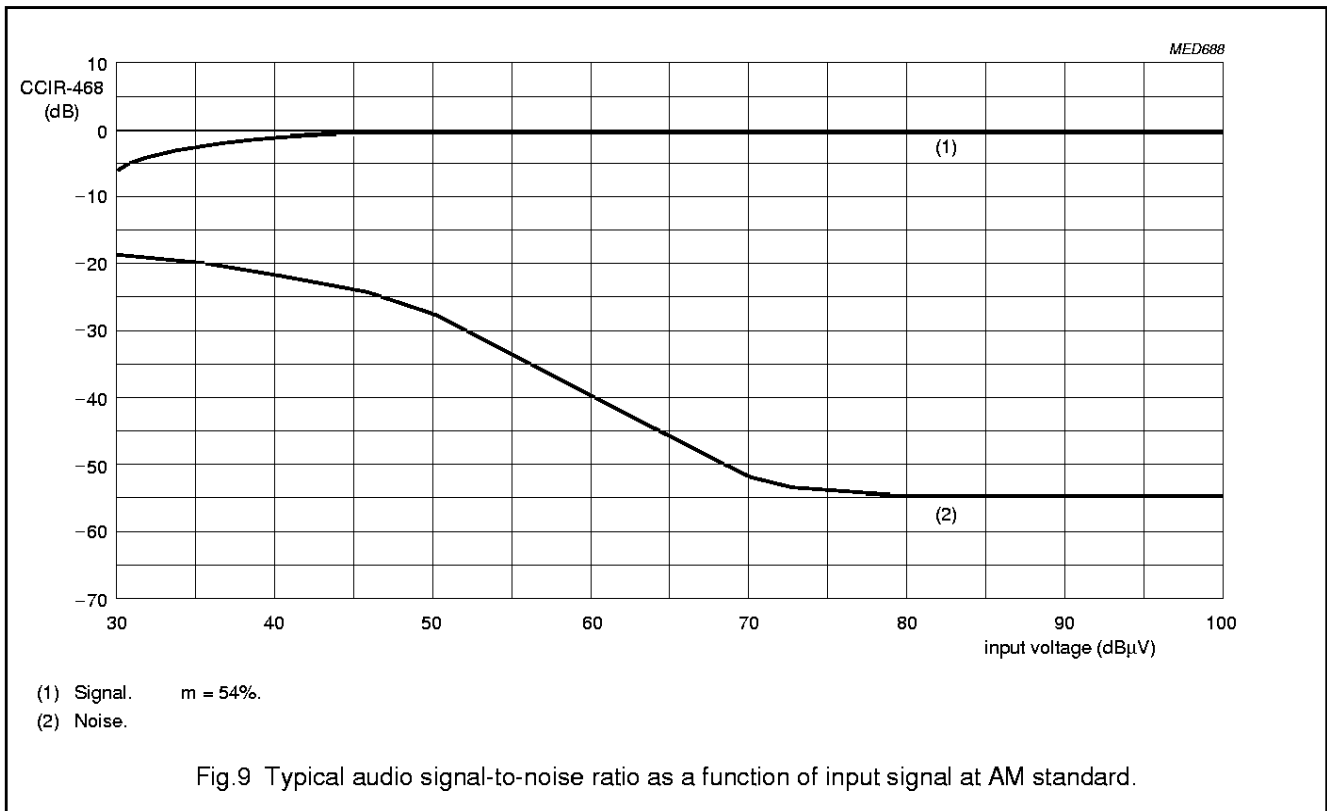
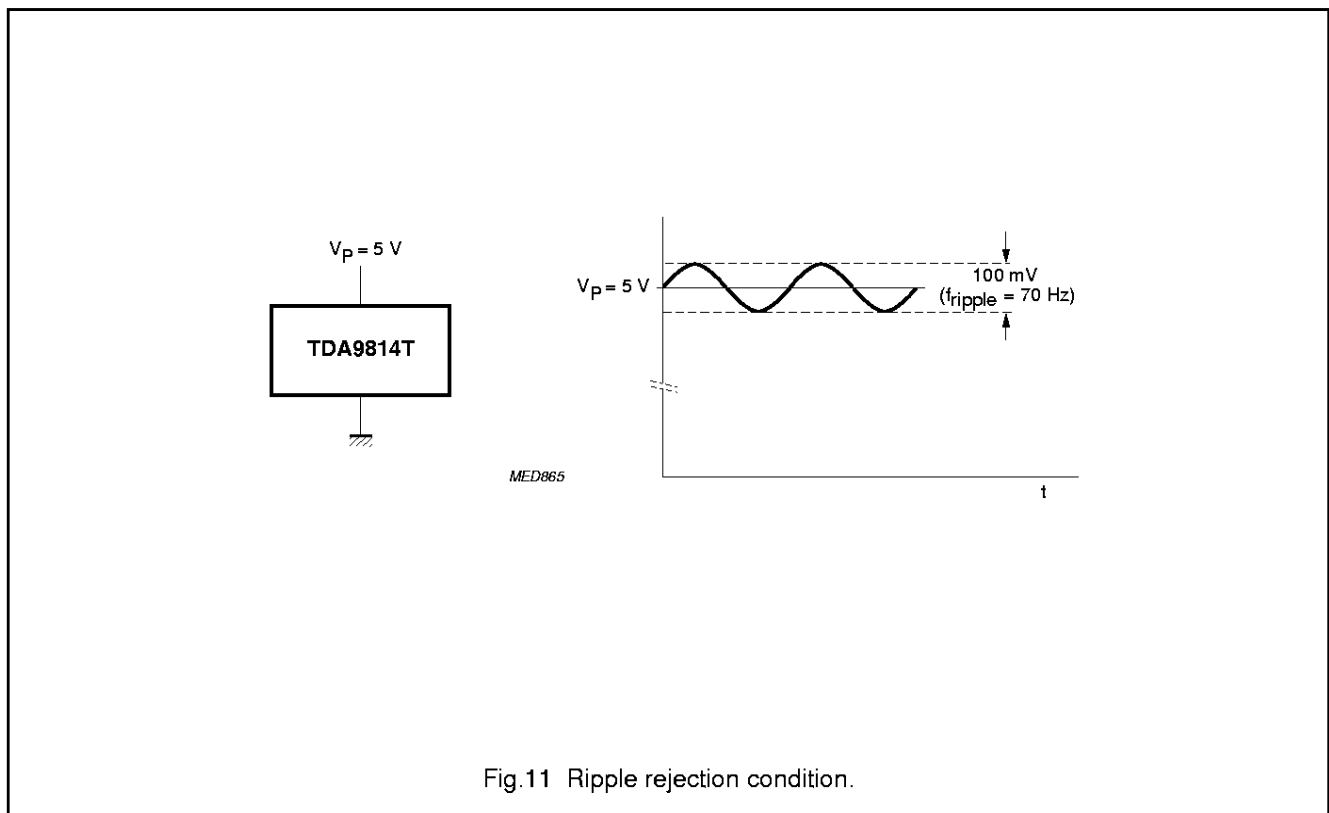
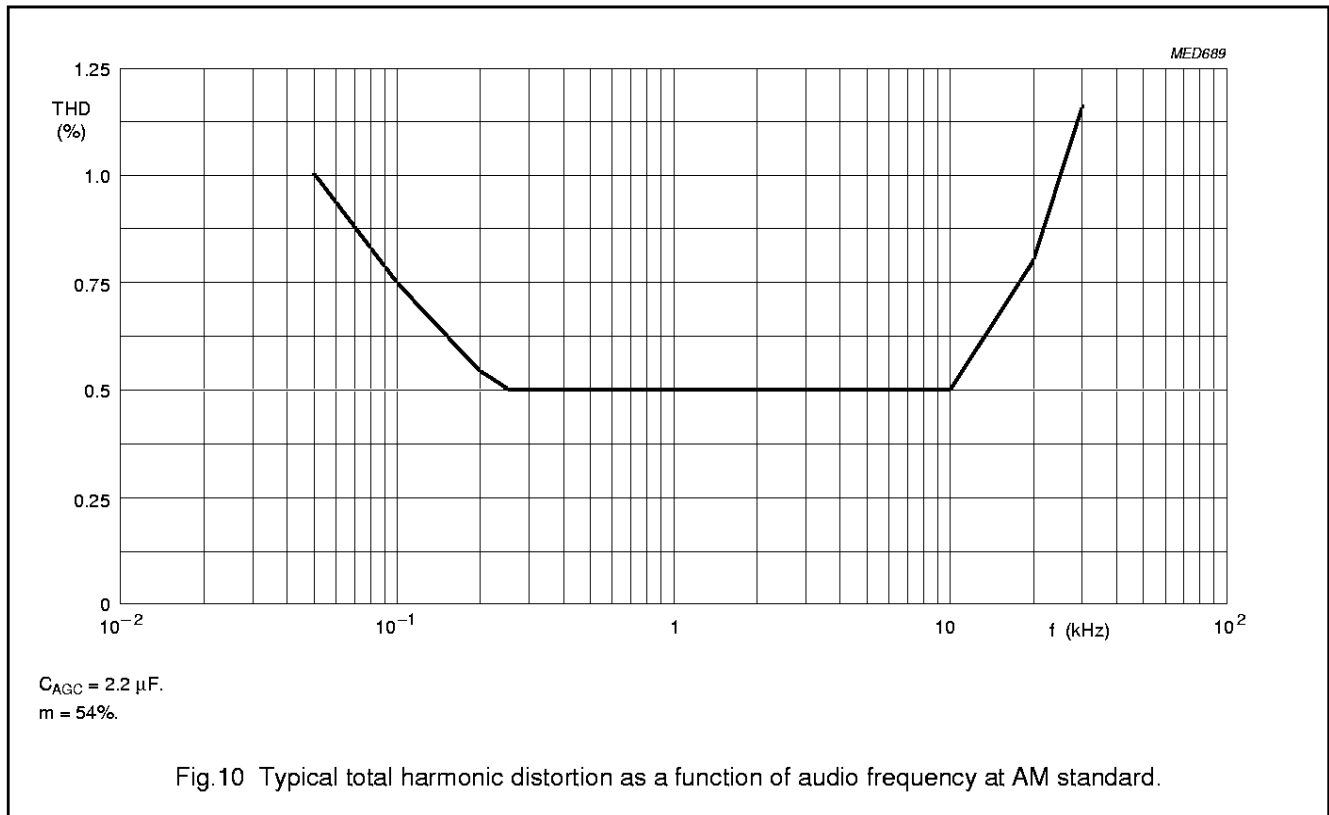

Fig.9 Typical audio signal-to-noise ratio as a function of input signal at AM standard.

Multistandard VIF-PLL with QSS-IF  
and dual FM-PLL/AM demodulator

TDA9814T



Multistandard VIF-PLL with QSS-IF  
and dual FM-PLL/AM demodulator

TDA9814T

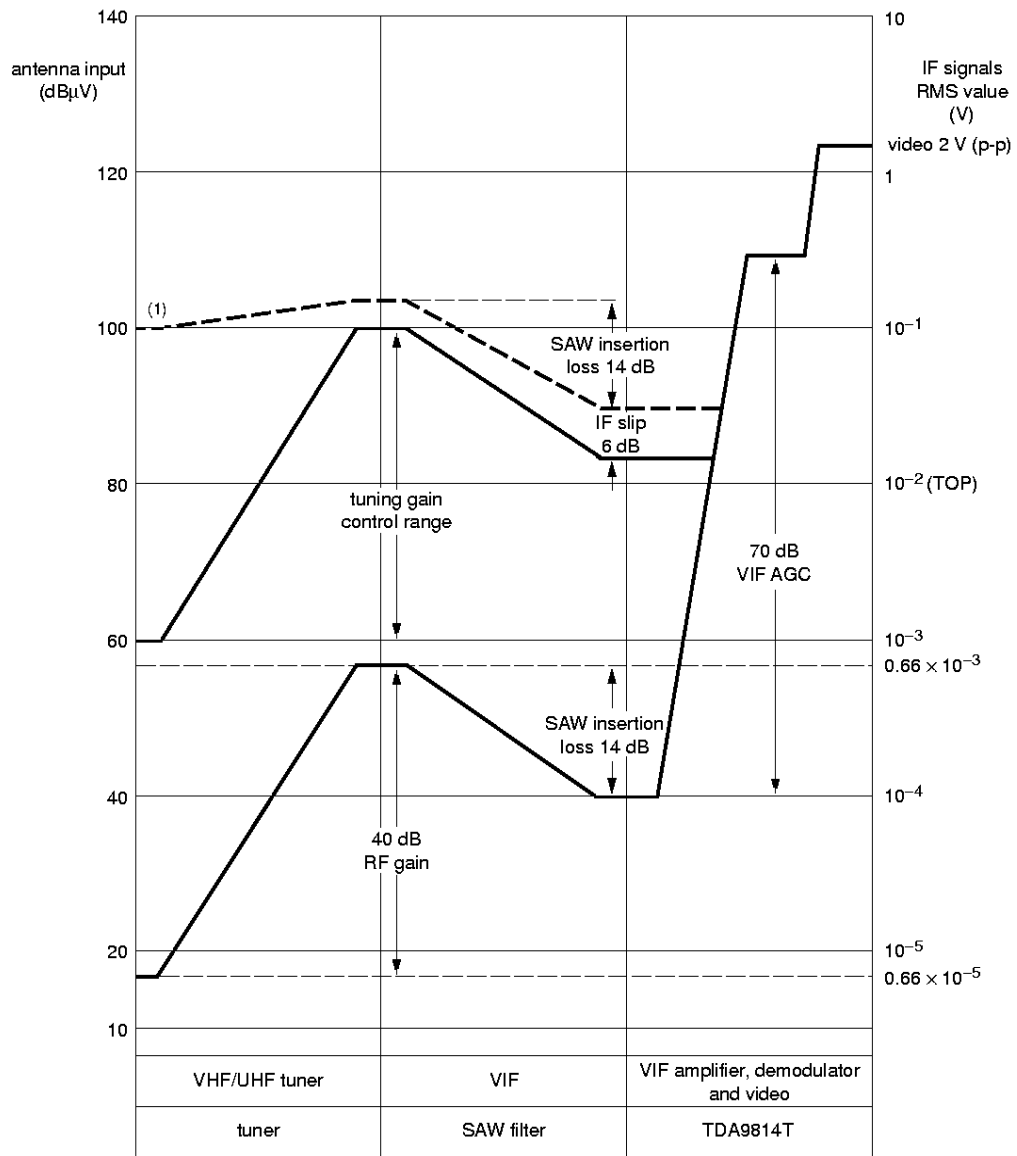

MHB019

(1) Depends on TOP.

Fig.12 Front end level diagram.

Multistandard VIF-PLL with QSS-IF  
and dual FM-PLL/AM demodulator

TDA9814T

INTERNAL CIRCUITRY

Table 3 Equivalent pin circuits and pin voltages

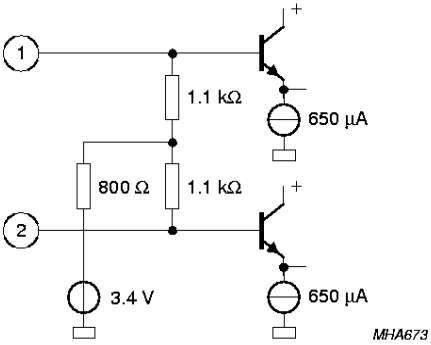
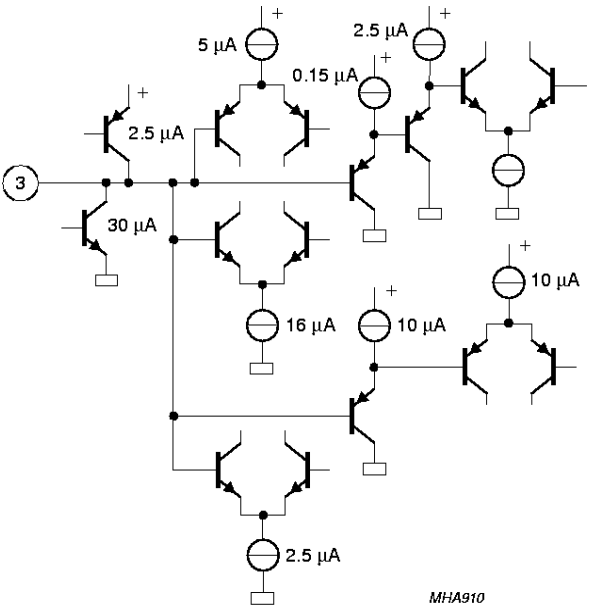
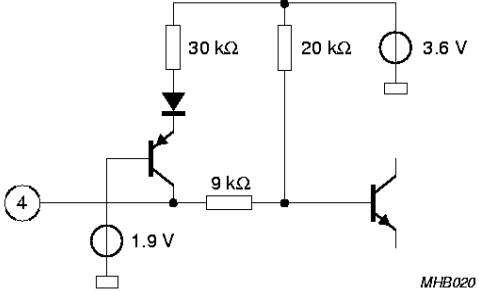
PIN NO.	PIN SYMBOL	DC VOLTAGE (V)	EQUIVALENT CIRCUIT (WITHOUT ESD PROTECTION CIRCUIT)
1 2	$V_{i VIF1}$ $V_{i VIF2}$	3.4 3.4	 <p style="text-align: right;"><i>MHA673</i></p>
3	$C_{BL}$	0 to 3.2	 <p style="text-align: right;"><i>MHA910</i></p>
4	TADJ	0 to 1.9	 <p style="text-align: right;"><i>MHB020</i></p>



Multistandard VIF-PLL with QSS-IF  
and dual FM-PLL/AM demodulator

TDA9814T

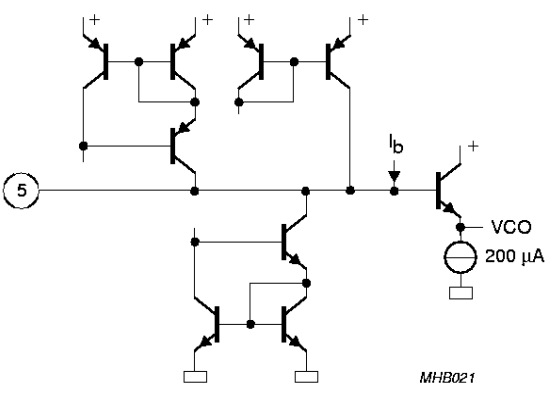
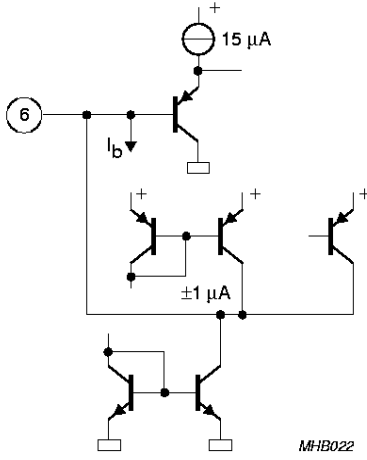
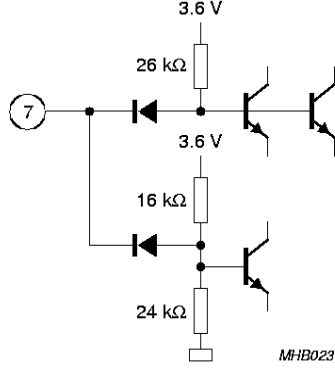
PIN NO.	PIN SYMBOL	DC VOLTAGE (V)	EQUIVALENT CIRCUIT (WITHOUT ESD PROTECTION CIRCUIT)
5	$T_{PLL}$	1.5 to 4.0	
6	$C_{SAGC}$	1.5 to 4.0	
7	STD	0 to $V_P$	

Multistandard VIF-PLL with QSS-IF  
and dual FM-PLL/AM demodulator

TDA9814T

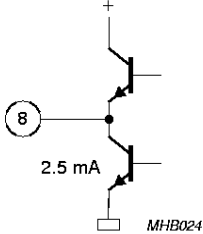
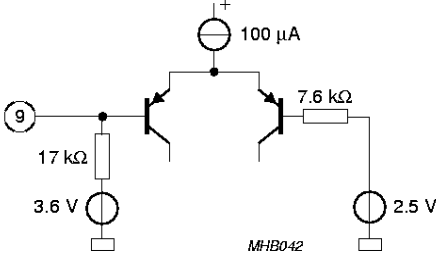
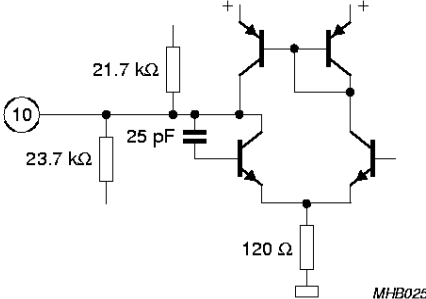
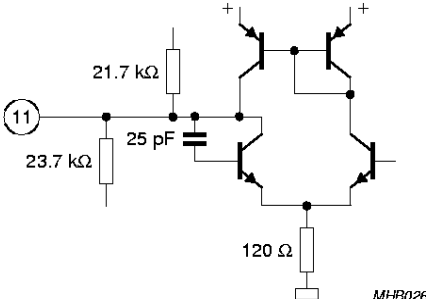
PIN NO.	PIN SYMBOL	DC VOLTAGE (V)	EQUIVALENT CIRCUIT (WITHOUT ESD PROTECTION CIRCUIT)
8	$V_{o\text{CVBS}}$	sync level: 1.35	
9	LSWI	0 to $V_P$	
10	$V_{o\text{AF1}}$	2.3	
11	$V_{o\text{AF2}}$	2.3	

Multistandard VIF-PLL with QSS-IF  
and dual FM-PLL/AM demodulator

TDA9814T

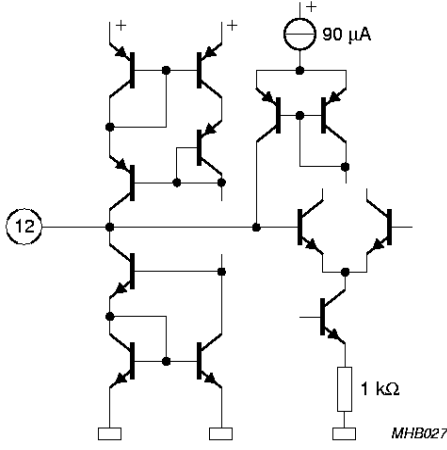
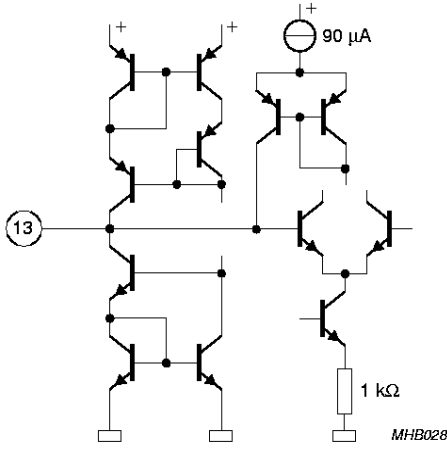
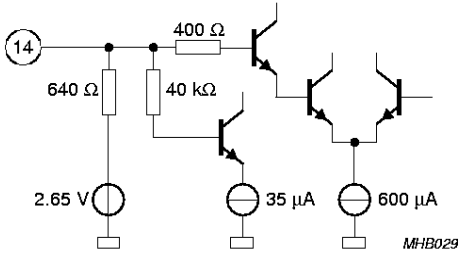
PIN NO.	PIN SYMBOL	DC VOLTAGE (V)	EQUIVALENT CIRCUIT (WITHOUT ESD PROTECTION CIRCUIT)
12	C <sub>DEC2</sub>	1.2 to 3.0	 <p>MHB027</p>
13	C <sub>DEC1</sub>	1.2 to 3.0	 <p>MHB028</p>
14	V <sub>i FM2</sub>	2.65	 <p>MHB029</p>

Multistandard VIF-PLL with QSS-IF  
and dual FM-PLL/AM demodulator

TDA9814T

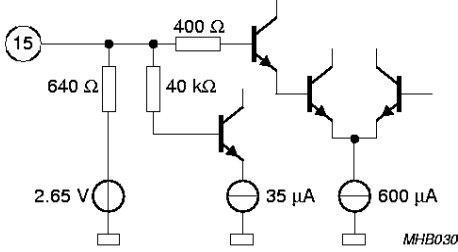
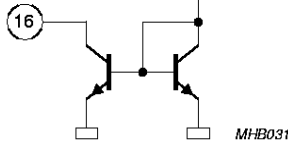
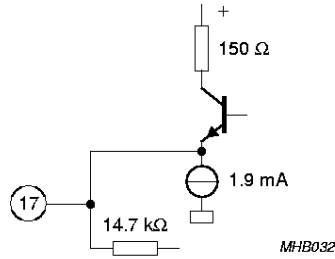
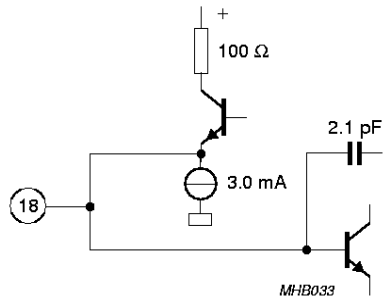
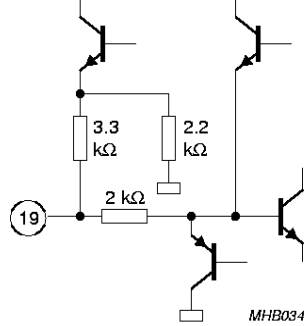
PIN NO.	PIN SYMBOL	DC VOLTAGE (V)	EQUIVALENT CIRCUIT (WITHOUT ESD PROTECTION CIRCUIT)
15	$V_{iFM1}$	2.65	
16	TAGC	0 to 13.2	
17	$V_{oQSS}$	2.0	
18	$V_{o(vid)}$	sync level: 1.5	
19	$V_{i(vid)}$	1.7	

Multistandard VIF-PLL with QSS-IF  
and dual FM-PLL/AM demodulator

TDA9814T

PIN NO.	PIN SYMBOL	DC VOLTAGE (V)	EQUIVALENT CIRCUIT (WITHOUT ESD PROTECTION CIRCUIT)
20	AFC	0.3 to $V_P - 0.3$	
21	VCO1	2.7	
22	VCO2	2.7	
23	$C_{ref}$	$\frac{1}{2}V_P$	
24	GND	0	

Multistandard VIF-PLL with QSS-IF  
and dual FM-PLL/AM demodulator

TDA9814T

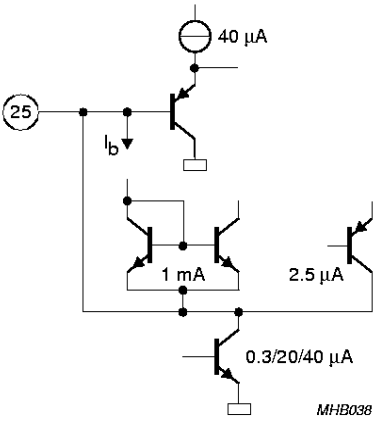
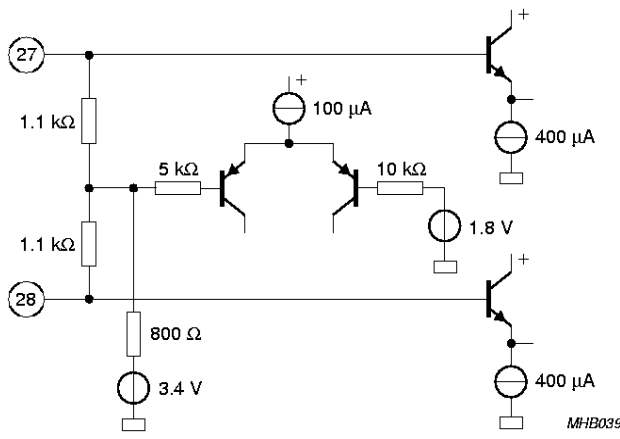
PIN NO.	PIN SYMBOL	DC VOLTAGE (V)	EQUIVALENT CIRCUIT (WITHOUT ESD PROTECTION CIRCUIT)
25	$C_{VAGC}$	1.5 to 4.0	
26	$V_P$	$V_P$	
27	$V_{i SIF1}$	3.4	
28	$V_{i SIF2}$	3.4	

# Multistandard VIF-PLL with QSS-IF and dual FM-PLL/AM demodulator

TDA9814T

## TEST AND APPLICATION INFORMATION

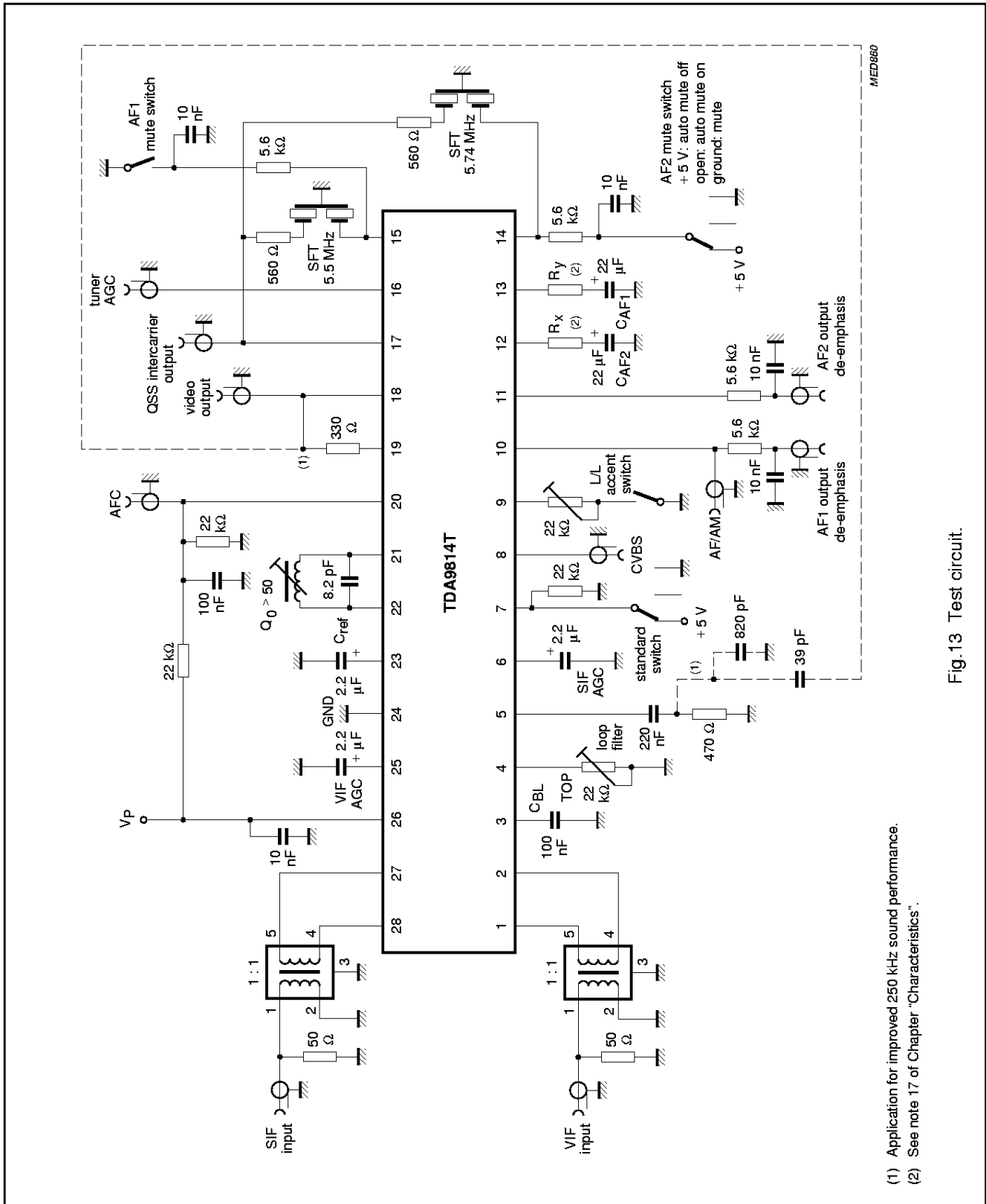

Fig.13 Test circuit.

# Multistandard VIF-PLL with QSS-IF and dual FM-PLL/AM demodulator

TDA9814T

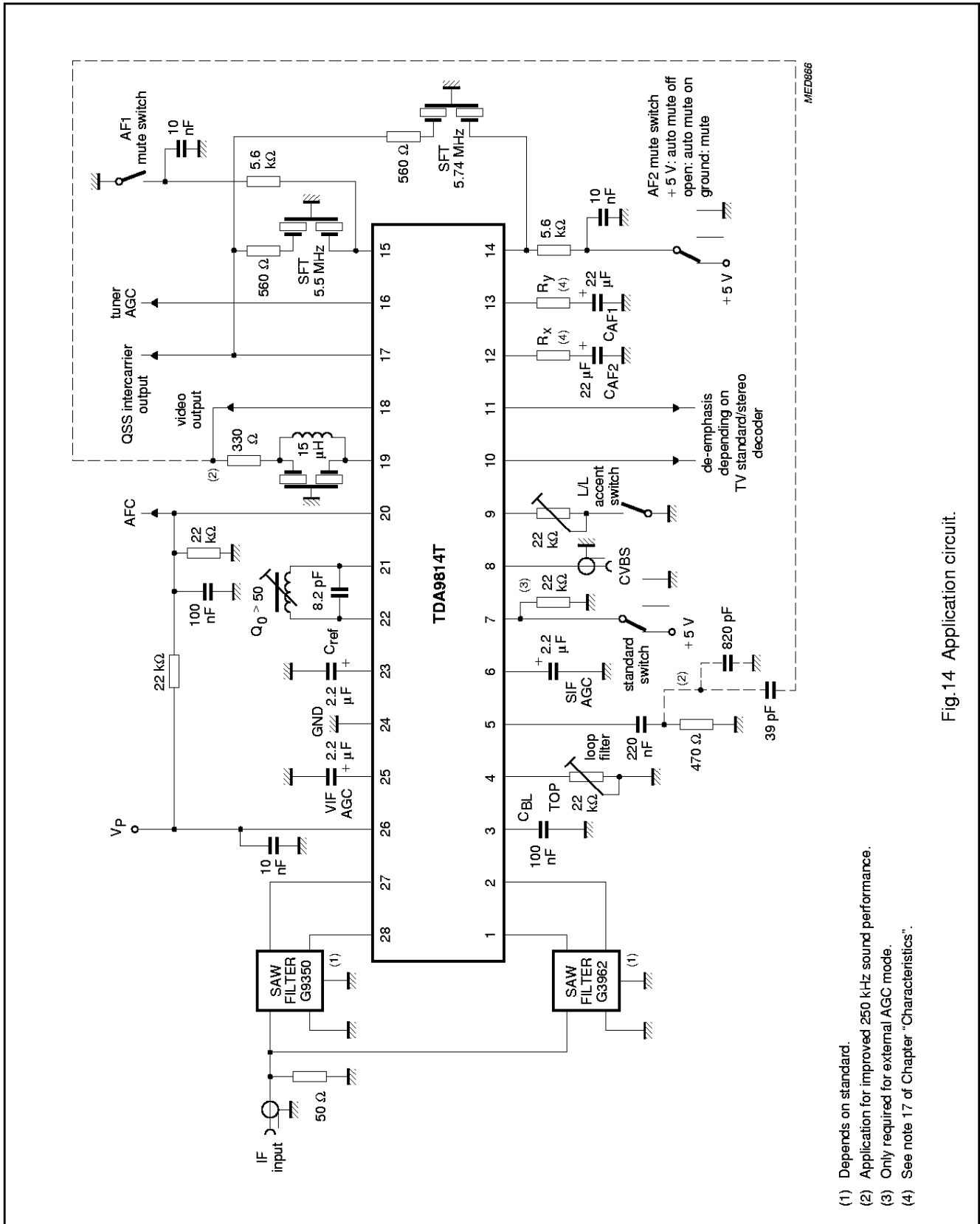

Fig.14 Application circuit.



Multistandard VIF-PLL with QSS-IF  
and dual FM-PLL/AM demodulator

TDA9814T

PACKAGE OUTLINE

SO28: plastic small outline package; 28 leads; body width 7.5 mm

SOT136-1

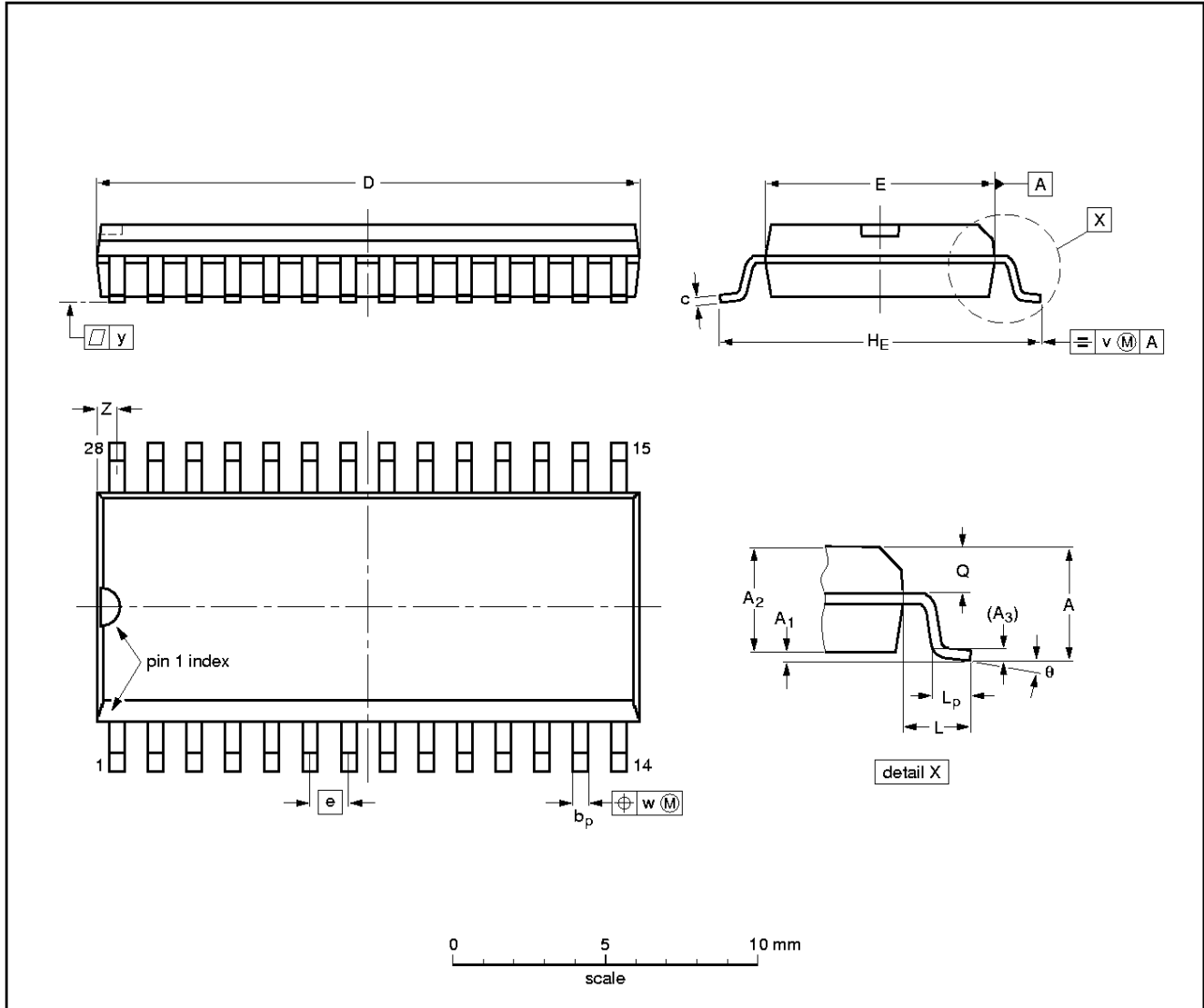

DIMENSIONS (inch dimensions are derived from the original mm dimensions)

UNIT	A max.	A <sub>1</sub>	A <sub>2</sub>	A <sub>3</sub>	b <sub>p</sub>	c	D <sup>(1)</sup>	E <sup>(1)</sup>	e	H <sub>E</sub>	L	L <sub>p</sub>	Q	v	w	y	Z <sup>(1)</sup>	θ
mm	2.65	0.30 0.10	2.45 2.25	0.25	0.49 0.36	0.32 0.23	18.1 17.7	7.6 7.4	1.27	10.65 10.00	1.4	1.1 0.4	1.1 1.0	0.25	0.25	0.1	0.9 0.4	8° 0°
inches	0.10	0.012 0.004	0.096 0.089	0.01	0.019 0.014	0.013 0.009	0.71 0.69	0.30 0.29	0.050	0.419 0.394	0.055	0.043 0.016	0.043 0.039	0.01	0.01	0.004	0.035 0.016	

Note

1. Plastic or metal protrusions of 0.15 mm maximum per side are not included.

OUTLINE VERSION	REFERENCES				EUROPEAN PROJECTION	ISSUE DATE
	IEC	JEDEC	EIAJ			
SOT136-1	075E06	MS-013AE				95-01-24 97-05-22

## Multistandard VIF-PLL with QSS-IF and dual FM-PLL/AM demodulator

TDA9814T

### SOLDERING

#### Introduction

There is no soldering method that is ideal for all IC packages. Wave soldering is often preferred when through-hole and surface mounted components are mixed on one printed-circuit board. However, wave soldering is not always suitable for surface mounted ICs, or for printed-circuits with high population densities. In these situations reflow soldering is often used.

This text gives a very brief insight to a complex technology. A more in-depth account of soldering ICs can be found in our *"IC Package Databook"* (order code 9398 652 90011).

#### Reflow soldering

Reflow soldering techniques are suitable for all SO packages.

Reflow soldering requires solder paste (a suspension of fine solder particles, flux and binding agent) to be applied to the printed-circuit board by screen printing, stencilling or pressure-syringe dispensing before package placement.

Several techniques exist for reflowing; for example, thermal conduction by heated belt. Dwell times vary between 50 and 300 seconds depending on heating method. Typical reflow temperatures range from 215 to 250 °C.

Preheating is necessary to dry the paste and evaporate the binding agent. Preheating duration: 45 minutes at 45 °C.

#### Wave soldering

Wave soldering techniques can be used for all SO packages if the following conditions are observed:

- A double-wave (a turbulent wave with high upward pressure followed by a smooth laminar wave) soldering technique should be used.
- The longitudinal axis of the package footprint must be parallel to the solder flow.
- The package footprint must incorporate solder thieves at the downstream end.

During placement and before soldering, the package must be fixed with a droplet of adhesive. The adhesive can be applied by screen printing, pin transfer or syringe dispensing. The package can be soldered after the adhesive is cured.

Maximum permissible solder temperature is 260 °C, and maximum duration of package immersion in solder is 10 seconds, if cooled to less than 150 °C within 6 seconds. Typical dwell time is 4 seconds at 250 °C.

A mildly-activated flux will eliminate the need for removal of corrosive residues in most applications.

#### Repairing soldered joints

Fix the component by first soldering two diagonally-opposite end leads. Use only a low voltage soldering iron (less than 24 V) applied to the flat part of the lead. Contact time must be limited to 10 seconds at up to 300 °C. When using a dedicated tool, all other leads can be soldered in one operation within 2 to 5 seconds between 270 and 320 °C.

# Multistandard VIF-PLL with QSS-IF and dual FM-PLL/AM demodulator

TDA9814T

## DEFINITIONS

<b>Data sheet status</b>	
Objective specification	This data sheet contains target or goal specifications for product development.
Preliminary specification	This data sheet contains preliminary data; supplementary data may be published later.
Product specification	This data sheet contains final product specifications.
<b>Limiting values</b>	
Limiting values given are in accordance with the Absolute Maximum Rating System (IEC 134). Stress above one or more of the limiting values may cause permanent damage to the device. These are stress ratings only and operation of the device at these or at any other conditions above those given in the Characteristics sections of the specification is not implied. Exposure to limiting values for extended periods may affect device reliability.	
<b>Application information</b>	
Where application information is given, it is advisory and does not form part of the specification.	

## LIFE SUPPORT APPLICATIONS

These products are not designed for use in life support appliances, devices, or systems where malfunction of these products can reasonably be expected to result in personal injury. Philips customers using or selling these products for use in such applications do so at their own risk and agree to fully indemnify Philips for any damages resulting from such improper use or sale.

# Philips Semiconductors – a worldwide company

**Argentina:** see South America

**Australia:** 34 Waterloo Road, NORTH RYDE, NSW 2113,  
Tel. +61 2 9805 4455, Fax. +61 2 9805 4466

**Austria:** Computerstr. 6, A-1101 WIEN, P.O. Box 213, Tel. +43 160 1010,  
Fax. +43 160 101 1210

**Belarus:** Hotel Minsk Business Center, Bld. 3, r. 1211, Volodarski Str. 6,  
220050 MINSK, Tel. +375 172 200 733, Fax. +375 172 200 773

**Belgium:** see The Netherlands

**Brazil:** see South America

**Bulgaria:** Philips Bulgaria Ltd., Energoproject, 15th floor,  
51 James Bouchier Blvd., 1407 SOFIA,  
Tel. +359 2 689 211, Fax. +359 2 689 102

**Canada:** PHILIPS SEMICONDUCTORS/COMPONENTS,  
Tel. +1 800 234 7381

**China/Hong Kong:** 501 Hong Kong Industrial Technology Centre,  
72 Tat Chee Avenue, Kowloon Tong, HONG KONG,  
Tel. +852 2319 7888, Fax. +852 2319 7700

**Colombia:** see South America

**Czech Republic:** see Austria

**Denmark:** Prags Boulevard 80, PB 1919, DK-2300 COPENHAGEN S,  
Tel. +45 32 88 2636, Fax. +45 31 57 0044

**Finland:** Sinikalliontie 3, FIN-02630 ESPOO,  
Tel. +358 9 615800, Fax. +358 9 61580920

**France:** 51 Rue Carnot, BP317, 92156 SURESNES Cedex,  
Tel. +33 1 40 99 6161, Fax. +33 1 40 99 6427

**Germany:** Hammerbrookstraße 69, D-20097 HAMBURG,  
Tel. +49 40 23 53 60, Fax. +49 40 23 536 300

**Greece:** No. 15, 25th March Street, GR 17778 TAVROS/ATHENS,  
Tel. +30 1 4894 339/239, Fax. +30 1 4814 240

**Hungary:** see Austria

**India:** Philips INDIA Ltd, Band Box Building, 2nd floor,  
254-D, Dr. Annie Besant Road, Worli, MUMBAI 400 025,  
Tel. +91 22 493 8541, Fax. +91 22 493 0966

**Indonesia:** see Singapore

**Ireland:** Newstead, Clonskeagh, DUBLIN 14,  
Tel. +353 1 7640 000, Fax. +353 1 7640 200

**Israel:** RAPAC Electronics, 7 Kehilat Saloniki St, PO Box 18053,  
TEL AVIV 61180, Tel. +972 3 645 0444, Fax. +972 3 649 1007

**Italy:** PHILIPS SEMICONDUCTORS, Piazza IV Novembre 3,  
20124 MILANO, Tel. +39 2 6752 2531, Fax. +39 2 6752 2557

**Japan:** Philips Bldg 13-37, Kohnan 2-chome, Minato-ku, TOKYO 108,  
Tel. +81 3 3740 5130, Fax. +81 3 3740 5077

**Korea:** Philips House, 260-199 Itaewon-dong, Yongsan-ku, SEOUL,  
Tel. +82 2 709 1412, Fax. +82 2 709 1415

**Malaysia:** No. 76 Jalan Universiti, 46200 PETALING JAYA, SELANGOR,  
Tel. +60 3 750 5214, Fax. +60 3 757 4880

**Mexico:** 5900 Gateway East, Suite 200, EL PASO, TEXAS 79905,  
Tel. +9-5 800 234 7381

**Middle East:** see Italy

**Netherlands:** Postbus 90050, 5600 PB EINDHOVEN, Bldg. VB,  
Tel. +31 40 27 82785, Fax. +31 40 27 88399

**New Zealand:** 2 Wagener Place, C.P.O. Box 1041, AUCKLAND,  
Tel. +64 9 849 4160, Fax. +64 9 849 7811

**Norway:** Box 1, Manglerud 0612, OSLO,  
Tel. +47 22 74 8000, Fax. +47 22 74 8341

**Philippines:** Philips Semiconductors Philippines Inc.,  
106 Valero St. Salcedo Village, P.O. Box 2108 MCC, MAKATI,  
Metro MANILA, Tel. +63 2 816 6380, Fax. +63 2 817 3474

**Poland:** Ul. Lukiska 10, PL 04-123 WARSZAWA,  
Tel. +48 22 612 2831, Fax. +48 22 612 2327

**Portugal:** see Spain

**Romania:** see Italy

**Russia:** Philips Russia, Ul. Usatcheva 35A, 119048 MOSCOW,  
Tel. +7 095 755 6918, Fax. +7 095 755 6919

**Singapore:** Lorong 1, Toa Payoh, SINGAPORE 1231,  
Tel. +65 350 2538, Fax. +65 251 6500

**Slovakia:** see Austria

**Slovenia:** see Italy

**South Africa:** S.A. PHILIPS Pty Ltd., 195-215 Main Road Martindale,  
2092 JOHANNESBURG, P.O. Box 7430 Johannesburg 2000,  
Tel. +27 11 470 5911, Fax. +27 11 470 5494

**South America:** Al. Vicente Pinzon, 173, 6th floor,  
04547-130 SÃO PAULO, SP, Brazil,  
Tel. +55 11 821 2333, Fax. +55 11 821 2382

**Spain:** Balmes 22, 08007 BARCELONA,  
Tel. +34 3 301 6312, Fax. +34 3 301 4107

**Sweden:** Kottbygatan 7, Akalla, S-16485 STOCKHOLM,  
Tel. +46 8 632 2000, Fax. +46 8 632 2745

**Switzerland:** Allmendstrasse 140, CH-8027 ZÜRICH,  
Tel. +41 1 488 2686, Fax. +41 1 488 3263

**Taiwan:** Philips Semiconductors, 6F, No. 96, Chien Kuo N. Rd., Sec. 1,  
TAIPEI, Taiwan Tel. +886 2 2134 2865, Fax. +886 2 2134 2874

**Thailand:** PHILIPS ELECTRONICS (THAILAND) Ltd.,  
209/2 Sanpavuth-Bangna Road Prakanong, BANGKOK 10260,  
Tel. +66 2 745 4090, Fax. +66 2 398 0793

**Turkey:** Talatpasa Cad. No. 5, 80640 GÜLTEPE/ISTANBUL,  
Tel. +90 212 279 2770, Fax. +90 212 282 6707

**Ukraine:** PHILIPS UKRAINE, 4 Patrice Lumumba str., Building B, Floor 7,  
252042 KIEV, Tel. +380 44 264 2776, Fax. +380 44 268 0461

**United Kingdom:** Philips Semiconductors Ltd., 276 Bath Road, Hayes,  
MIDDLESEX UB3 5BX, Tel. +44 181 730 5000, Fax. +44 181 754 8421

**United States:** 811 East Arques Avenue, SUNNYVALE, CA 94088-3409,  
Tel. +1 800 234 7381

**Uruguay:** see South America

**Vietnam:** see Singapore

**Yugoslavia:** PHILIPS, Trg N. Pasica 5/v, 11000 BEOGRAD,  
Tel. +381 11 625 344, Fax. +381 11 635 777

For all other countries apply to: Philips Semiconductors,  
International Marketing & Sales Communications, Building BE-p, P.O. Box 218,  
5600 MD EINDHOVEN, The Netherlands, Fax. +31 40 27 24825

Internet: <http://www.semiconductors.philips.com>

© Philips Electronics N.V. 1998

SCA57

All rights are reserved. Reproduction in whole or in part is prohibited without the prior written consent of the copyright owner.

The information presented in this document does not form part of any quotation or contract, is believed to be accurate and reliable and may be changed without notice. No liability will be accepted by the publisher for any consequence of its use. Publication thereof does not convey nor imply any license under patent- or other industrial or intellectual property rights.

Printed in The Netherlands

545104/1200/04/pp36

Date of release: 1998 Feb 09

Document order number: 9397 750 03001

*Let's make things better*

**Philips  
Semiconductors**



**PHILIPS**