

Technical Data

DV74HCT112 Available Q2, 1995

Dual J-K Flip-Flop with Set and Reset

This device identical in pinout to the LS112. Each flip-flop is negative-edge clocked and has active-low asynchronous Set and Reset inputs.

- Output Drive Capability: 10 LSTTL Loads
- Outputs Directly Interface to CMOS, NMOS, and TTL
- Operating Voltage Range: 2 to 6 V for HC devices
- Low Input Current: 1 μ A
- DC, AC parameters guaranteed from -55°C to 125°C

DV74HC112
DV74HCT112

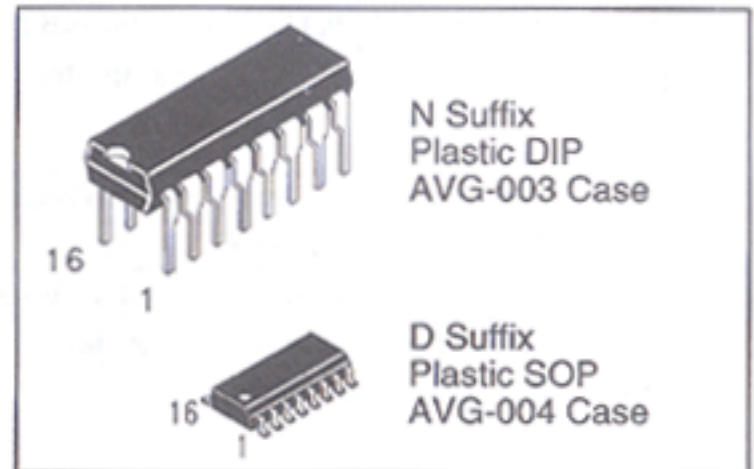

112

PIN ASSIGNMENT

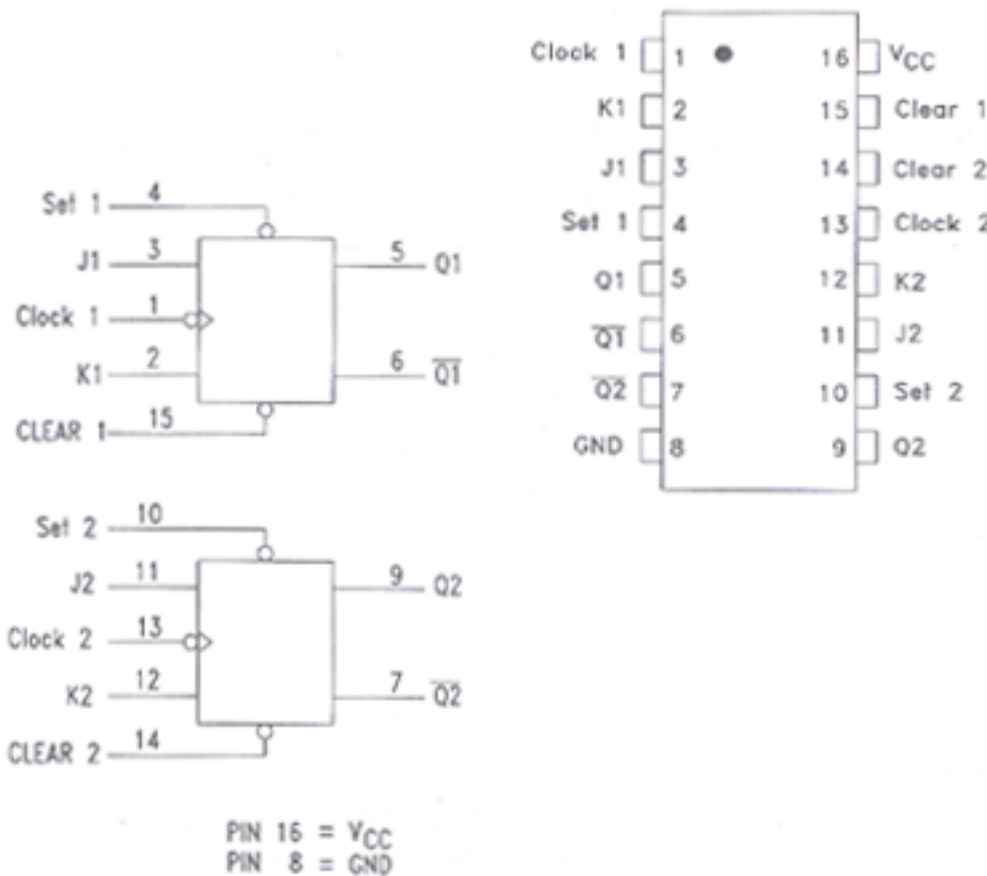

TRUTH TABLE

Inputs					Outputs	
Set	Reset	Clock	J	K	Q	Q̄
L	H	X	X	X	H	L
H	L	X	X	X	L	H
L	L	X	X	X	L*	L*
H	H	↓	L	L	No Change	
H	H	↓	L	H	L	H
H	H	↓	H	L	H	L
H	H	↓	H	H	Toggle	
H	H	L	X	X	No Change	
H	H	H	X	X	No Change	
H	H	↑	X	X	No Change	

*Both outputs will remain low as long as Set and Reset are low, but the output states are unpredictable if Set and Reset go high simultaneously

H = High Logic Level

L = Low logic Level

↑ = Low to High Transition

↓ = High to Low Transition

X = Don't Care

ABSOLUTE MAXIMUM RATINGS

Maximum ratings are those values beyond which damage to the device may occur.

Symbol	Parameter	Value	Unit
V _{CC}	DC Supply Voltage (Referenced to GND)	-0.5 to +7.0	V
V _{IN}	DC Input Voltage (Referenced to GND)	-1.5 to V _{CC} +1.5	V
V _{OUT}	DC Output Voltage (Referenced to GND)	-0.5 to V _{CC} +0.5	V
I _{IN}	DC Input Current, per Pin	± 20	mA
I _{OUT}	DC Output Current, per Pin	± 25	mA
I _{CC}	DC Supply Current, V _{CC} and GND Pins	± 50	mA
P _D	Power Dissipation in Still Air, Plastic DIP SOP Package	750 500	mW
T _{STG}	Storage Temperature Range	-65 to +150	°C
T _L	Lead Temperature, 1mm from Case for 10 Seconds	260	°C

GUARANTEED OPERATING CONDITIONS

Symbol	Parameter	Min	Max	Unit
V _{CC}	DC Supply Voltage, HC (HCT), Referenced to GND	2.0 (4.5)	6.0 (5.5)	V
V _{IN} , V _{OUT}	DC Input Voltage, Output Voltage, Referenced to GND	0	V _{CC}	V
T _A	Ambient Temperature	-55	+125	°C
t _r , t _f	Input Rise and Fall Time: HC: V _{CC} =2.0V HCT: V _{CC} =5.5V / HC: V _{CC} =4.5V HC: V _{CC} =6.0V	0 0 0	1000 500 400	ns

HC - 112

DC ELECTRICAL CHARACTERISTICS

Symbol	Parameter	Conditions	V _{CC} V	Guaranteed Limits			Unit
				25°C to -55°C	≤85°C	≤125°C	
V _{IH}	Minimum High-Level Input Voltage	V _{OUT} = 0.1 V, I _{OUT} ≤ 20 μA or V _{OUT} = V _{CC} - 0.1 V	2.0	1.5	1.5	1.5	V
			4.5	3.15	3.15	3.15	
			6.0	4.2	4.2	4.2	
V _{IL}	Maximum Low-Level Input Voltage	V _{OUT} = 0.1 V, I _{OUT} ≤ 20 μA or V _{OUT} = V _{CC} - 0.1 V	2.0	0.3	0.3	0.3	V
			4.5	0.9	0.9	0.9	
			6.0	1.2	1.2	1.2	
V _{OH}	Minimum High-Level Output Voltage	V _{IN} = V _{IH} or V _{IL} I _{OUT} ≤ 20 μA	2.0	1.9	1.9	1.9	V
			4.5	4.4	4.4	4.4	
		6.0	5.9	5.9	5.9		
		V _{IN} = V _{IH} or V _{IL} , I _{OUT} ≤ 4.0 mA I _{OUT} ≤ 5.2 mA	4.5	3.98	3.84	3.7	
V _{OL}	Maximum Low Level Output Voltage	V _{IN} = V _{IH} or V _{IL} I _{OUT} ≤ 20 μA	2.0	0.1	0.1	0.1	V
			4.5	0.1	0.1	0.1	
		6.0	0.1	0.1	0.1		
		V _{IN} = V _{IH} or V _{IL} , I _{OUT} ≤ 4.0 mA I _{OUT} ≤ 5.2 mA	4.5	0.26	0.33	0.40	
I _{IN}	Maximum Input Leakage Current	V _{IN} = V _{CC} or GND	6.0	±0.1	±1.0	±1.0	μA
I _{CC}	Maximum Quiescent Supply Current	V _{IN} = V _{CC} or GND, I _{OUT} ≤ 0 μA	6.0	4.0	40	80	μA

AC ELECTRICAL CHARACTERISTICS over full operating conditions (C_L=50pF, Input t_r=t_f=6ns)

Symbol	Parameter	V _{CC} V	Guaranteed Limit			Unit
			25°C to -55°C	≤85°C	≤125°C	
f _{max}	Maximum Clock Frequency (50% Cycle)	2.0	6.0	4.8	4.0	MHz
		4.5	30	24	20	
		6.0	35	28	24	
t _{PLH} , t _{PHL}	Maximum Propagation Delay Time, Clock to Q or \bar{Q}	2.0	125	155	190	ns
		4.5	25	31	38	
		6.0	21	26	32	
t _{PLH} , t _{PHL}	Maximum Propagation Delay Time, Reset to Q or \bar{Q}	2.0	155	195	235	ns
		4.5	31	39	47	
		6.0	26	33	40	
t _{PLH} , t _{PHL}	Maximum Propagation Delay Time, Set to Q or \bar{Q}	2.0	165	205	250	ns
		4.5	33	41	50	
		6.0	28	35	43	
t _{TLH} , t _{THL}	Maximum Output Transition Time Any Output	2.0	75	95	110	ns
		4.5	15	19	22	
		6.0	13	16	19	
C _{IN}	Maximum Input Capacitance	—	10	10	10	pF

C _{PD}	Power Dissipation Capacitance (Per Gate) Used to determine the no-load dynamic power consumption, $P_D = C_{PD} V_{CC}^2 f + I_{CC} V_{CC}$	Typical @ 25°C, V _{CC} = 5 V			pF
		35			

TIMING REQUIREMENTS (Input t_r=t_f=6 ns)

Symbol	Parameter	V _{CC} V	Guaranteed Limit			Unit
			25°C to -55°C	≤85°C	≤125°C	
t _{su}	Minimum Setup Time, J or K to Clock	2.0	100	125	150	ns
		4.5	20	25	30	
		6.0	17	21	26	
t _h	Minimum Hold Time, Clock to J or K	2.0	3	3	3	ns
		4.5	3	3	3	
		6.0	3	3	3	
t _{rec}	Minimum Recovery Time, Set or Reset Inactive to Clock	2.0	100	125	150	ns
		4.5	20	25	30	
		6.0	17	21	26	
t _w	Minimum Pulse Width, Set or Reset	2.0	80	100	120	ns
		4.5	16	20	24	
		6.0	14	17	20	
t _w	Minimum Pulse Width, Clock	2.0	80	100	120	ns
		4.5	16	20	24	
		6.0	14	17	20	

HCT-112

DC ELECTRICAL CHARACTERISTICS

Symbol	Parameter	Conditions	V _{CC} V	Guaranteed Limits						Unit
				25°C to -55°C		≤85°C		≤125°C		
				Min	Max	Min	Max	Min	Max	
V _{IH}	Minimum High-Level Input Voltage	V _{OUT} = 0.1 V or V _{CC} -0.1 V I _{OUT} ≤ 20 μA	4.5	2.00		2.00		2.00		V
			5.5	2.00		2.00		2.00		
V _{IL}	Maximum Low-Level Input Voltage	V _{OUT} = 0.1 V or V _{CC} -0.1 V I _{OUT} ≤ 20 μA	4.5		0.80		0.80		0.80	V
			5.5		0.80		0.80		0.80	
V _{OH}	Minimum High-Level Output Voltage	V _{IN} = V _{IL} or V _{IH} I _{OUT} ≤ 20 μA	4.5	4.40		4.40		4.40		V
		V _{IN} = V _{IL} or V _{IH} I _{OUT} ≤ 4.0 mA	4.5	3.98		3.84		3.70		
V _{OL}	Maximum Low Level Output Voltage	V _{IN} = V _{IH} or V _{IL} I _{OUT} ≤ 20 μA	4.5		0.1		0.1		0.1	V
		V _{IN} = V _{IH} or V _{IL} I _{OUT} ≤ 4.0 mA	4.5		0.26		0.33		0.40	
I _{IN}	Maximum Input Leakage Current	V _{IN} = V _{CC} or GND	5.5		±0.1		±1.0		±1.0	μA
I _{CC}	Maximum Quiescent Supply Current	V _{IN} = V _{CC} or GND I _{OUT} = 0 μA	5.5		4.0		40		80	μA
Δ I _{CC}	Additional Quiescent Supply Current	V _{IN} = 2.4V, Any One Input V _{IN} = V _{CC} or GND, Other Inputs I _{OUT} = 0 μA	5.5	≥ -55°C		25°C to 125°C				mA
				2.9		2.4				

AC ELECTRICAL CHARACTERISTICS over full operating conditions (CL=50pF, Input $t_f=t_r=6\text{ns}$)

Symbol	Parameter	V _{CC} V	Guaranteed Limit			Unit
			25°C to -55°C	≤85°C	≤125°C	
f _{max}	Maximum Clock Frequency (50% Cycle)	5.0	30	24	20	MHz
t _{PLH} , t _{PHL}	Maximum Propagation Delay Time, Clock to Q or \bar{Q}	5.0	35	44	53	ns
t _{PLH} , t _{PHL}	Maximum Propagation Delay Time, Set or Reset to Q or \bar{Q}	5.0	46	58	69	ns
t _{TLH} , t _{THL}	Maximum Output Transition Time Any Output	5.0	15	19	22	ns
C _{IN}	Maximum Input Capacitance	—	10	10	10	pF

C _{PD}	Power Dissipation Capacitance (Per Inverter) Used to determine the no-load dynamic power consumption, $P_D = C_{PD} V_{CC}^2 f + I_{CC} V_{CC}$	Typical @ 25°C, V _{CC} = 5 V	Unit
		15	pF

TIMING REQUIREMENTS (Input $t_f=t_r=6\text{ ns}$)

Symbol	Parameter	V _{CC}	Guaranteed Limit			Unit
			25°C to -55°C	≤85°C	≤125 °C	
t _{su}	Minimum Setup Time, J or \bar{K} to Clock	5.0	20	25	30	ns
t _h	Minimum Hold Time, Clock to J or \bar{K}	5.0	5	5	5	ns
t _{rec}	Minimum Recovery Time, Set or Reset Inactive to Clock	5.0	5	5	5	ns
t _w	Minimum Pulse Width, Set or Reset	5.0	16	20	24	ns
t _w	Minimum Pulse Width, Clock	5.0	16	20	24	ns

SWITCHING WAVEFORMS

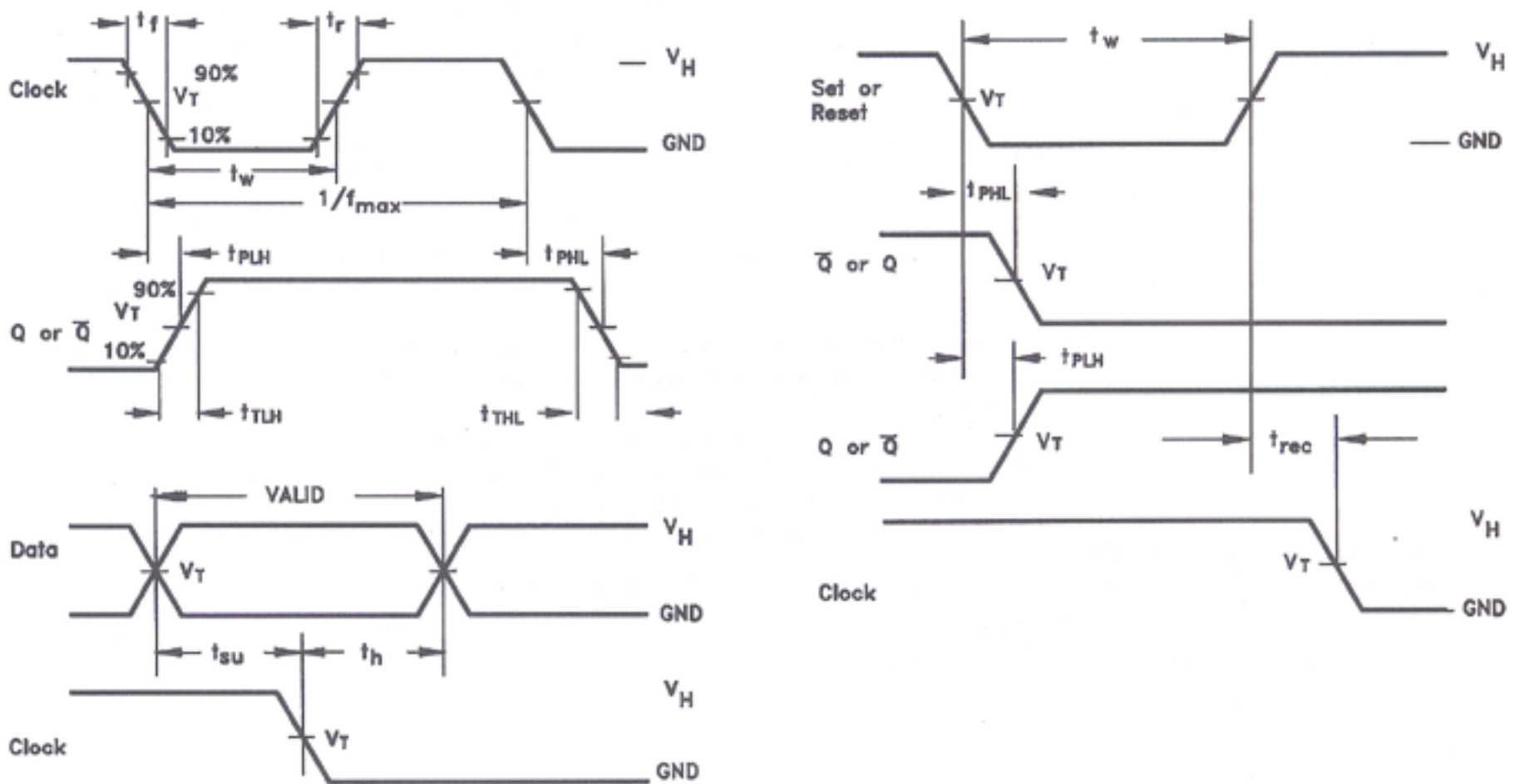

Input and Output Threshold Voltage: $V_T = 50\% V_{CC}$ for HC, 1.3V for HCT, $V_H = V_{CC}$ for HC, 3V for HCT