

To our customers,

Old Company Name in Catalogs and Other Documents

On April 1st, 2010, NEC Electronics Corporation merged with Renesas Technology Corporation, and Renesas Electronics Corporation took over all the business of both companies. Therefore, although the old company name remains in this document, it is a valid Renesas Electronics document. We appreciate your understanding.

Renesas Electronics website: <http://www.renesas.com>

April 1st, 2010
Renesas Electronics Corporation

Issued by: Renesas Electronics Corporation (<http://www.renesas.com>)

Send any inquiries to <http://www.renesas.com/inquiry>.

Not recommended
for new design

Notice

1. All information included in this document is current as of the date this document is issued. Such information, however, is subject to change without any prior notice. Before purchasing or using any Renesas Electronics products listed herein, please confirm the latest product information with a Renesas Electronics sales office. Also, please pay regular and careful attention to additional and different information to be disclosed by Renesas Electronics such as that disclosed through our website.
2. Renesas Electronics does not assume any liability for infringement of patents, copyrights, or other intellectual property rights of third parties by or arising from the use of Renesas Electronics products or technical information described in this document. No license, express, implied or otherwise, is granted hereby under any patents, copyrights or other intellectual property rights of Renesas Electronics or others.
3. You should not alter, modify, copy, or otherwise misappropriate any Renesas Electronics product, whether in whole or in part.
4. Descriptions of circuits, software and other related information in this document are provided only to illustrate the operation of semiconductor products and application examples. You are fully responsible for the incorporation of these circuits, software, and information in the design of your equipment. Renesas Electronics assumes no responsibility for any losses incurred by you or third parties arising from the use of these circuits, software, or information.
5. When exporting the products or technology described in this document, you should comply with the applicable export control laws and regulations and follow the procedures required by such laws and regulations. You should not use Renesas Electronics products or the technology described in this document for any purpose relating to military applications or use by the military, including but not limited to the development of weapons of mass destruction. Renesas Electronics products and technology may not be used for or incorporated into any products or systems whose manufacture, use, or sale is prohibited under any applicable domestic or foreign laws or regulations.
6. Renesas Electronics has used reasonable care in preparing the information included in this document, but Renesas Electronics does not warrant that such information is error free. Renesas Electronics assumes no liability whatsoever for any damages incurred by you resulting from errors in or omissions from the information included herein.
7. Renesas Electronics products are classified according to the following three quality grades: “Standard”, “High Quality”, and “Specific”. The recommended applications for each Renesas Electronics product depends on the product’s quality grade, as indicated below. You must check the quality grade of each Renesas Electronics product before using it in a particular application. You may not use any Renesas Electronics product for any application categorized as “Specific” without the prior written consent of Renesas Electronics. Further, you may not use any Renesas Electronics product for any application for which it is not intended without the prior written consent of Renesas Electronics. Renesas Electronics shall not be in any way liable for any damages or losses incurred by you or third parties arising from the use of any Renesas Electronics product for an application categorized as “Specific” or for which the product is not intended where you have failed to obtain the prior written consent of Renesas Electronics. The quality grade of each Renesas Electronics product is “Standard” unless otherwise expressly specified in a Renesas Electronics data sheets or data books, etc.
 - “Standard”: Computers; office equipment; communications equipment; test and measurement equipment; audio and visual equipment; home electronic appliances; machine tools; personal electronic equipment; and industrial robots.
 - “High Quality”: Transportation equipment (automobiles, trains, ships, etc.); traffic control systems; anti-disaster systems; anti-crime systems; safety equipment; and medical equipment not specifically designed for life support.
 - “Specific”: Aircraft; aerospace equipment; submersible repeaters; nuclear reactor control systems; medical equipment or systems for life support (e.g. artificial life support devices or systems), surgical implantations, or healthcare intervention (e.g. excision, etc.), and any other applications or purposes that pose a direct threat to human life.
8. You should use the Renesas Electronics products described in this document within the range specified by Renesas Electronics, especially with respect to the maximum rating, operating supply voltage range, movement power voltage range, heat radiation characteristics, installation and other product characteristics. Renesas Electronics shall have no liability for malfunctions or damages arising out of the use of Renesas Electronics products beyond such specified ranges.
9. Although Renesas Electronics endeavors to improve the quality and reliability of its products, semiconductor products have specific characteristics such as the occurrence of failure at a certain rate and malfunctions under certain use conditions. Further, Renesas Electronics products are not subject to radiation resistance design. Please be sure to implement safety measures to guard them against the possibility of physical injury, and injury or damage caused by fire in the event of the failure of a Renesas Electronics product, such as safety design for hardware and software including but not limited to redundancy, fire control and malfunction prevention, appropriate treatment for aging degradation or any other appropriate measures. Because the evaluation of microcomputer software alone is very difficult, please evaluate the safety of the final products or system manufactured by you.
10. Please contact a Renesas Electronics sales office for details as to environmental matters such as the environmental compatibility of each Renesas Electronics product. Please use Renesas Electronics products in compliance with all applicable laws and regulations that regulate the inclusion or use of controlled substances, including without limitation, the EU RoHS Directive. Renesas Electronics assumes no liability for damages or losses occurring as a result of your noncompliance with applicable laws and regulations.
11. This document may not be reproduced or duplicated, in any form, in whole or in part, without prior written consent of Renesas Electronics.
12. Please contact a Renesas Electronics sales office if you have any questions regarding the information contained in this document or Renesas Electronics products, or if you have any other inquiries.

(Note 1) “Renesas Electronics” as used in this document means Renesas Electronics Corporation and also includes its majority-owned subsidiaries.

(Note 2) “Renesas Electronics product(s)” means any product developed or manufactured by or for Renesas Electronics.

LDMOS FIELD EFFECT TRANSISTOR

NEM091603P-28

N-CHANNEL SILICON POWER LDMOS FET FOR 160 W UHF-BAND SINGLE-END POWER AMPLIFIER

DESCRIPTION

The NEM091603P-28 is an N-channel enhancement-mode lateral diffused MOS FET designed for 800 to 1 000 MHz applications, such as, GSM/EDGE/N-CDMA/W-CDMA/cdma2000 cellular base station. Dies are manufactured using our NEWMOS technology (our WSi gate lateral MOS FET), and its nitride surface passivation and multi layer aluminum silicon metallization offer a high degree of reliability.

FEATURES

- High 1 dB compression output power : $P_{O(1\text{ dB})} = 160\text{ W TYP.}$ ($V_{DS} = 28\text{ V}$, $I_{Dset} = 1\ 200\text{ mA}$, $f = 860\text{ to }880\text{ MHz CW}$)
- High linear gain : $G_L = 19.5\text{ dB TYP.}$ ($V_{DS} = 28\text{ V}$, $I_{Dset} = 1\ 200\text{ mA}$, $f = 860\text{ to }880\text{ MHz CW}$)
- High drain efficiency : $\eta_d = 60\% \text{ TYP.}$ ($V_{DS} = 28\text{ V}$, $I_{Dset} = 1\ 200\text{ mA}$, $f = 860\text{ to }880\text{ MHz CW}$)
- Low intermodulation distortion : $IM_3 = -40\text{ dBc TYP.}$ ($V_{DS} = 28\text{ V}$, $I_{Dset} = 1\ 200\text{ mA}$, $f = 880/880.1\text{ MHz}$, $P_{out} = 46.5\text{ dBm (2 tones)}$)
: $IM_3 = -40\text{ dBc TYP.}$ ($V_{DS} = 28\text{ V}$, $I_{Dset} = 1\ 200\text{ mA}$, $f = 960/960.1\text{ MHz}$, $P_{out} = 46.0\text{ dBm (2 tones)}$)
- Internal matched (Input and Output) for ease of use
- Low cost hollow plastic packages
- 100% screening
- Integrated ESD protection
- Effective prevention against humidity
- Excellent stability against HCI (Hot Carrier Injection)

APPLICATION

- Digital cellular base station PA : GSM/EDGE/N-CDMA/W-CDMA/cdma2000 etc.

ORDERING INFORMATION

Part Number	Order Number	Package	Supplying Form
NEM091603P-28	NEM091603P-28-A	T-97M (3P) (Pb-Free)	ESD protective envelope

Remark To order evaluation samples, contact your nearby sales office.
The unit sample quantity is 1 pcs.

Caution Observe precautions when handling because these devices are sensitive to electrostatic discharge.

The information in this document is subject to change without notice. Before using this document, please confirm that this is the latest version.
Not all products and/or types are available in every country. Please check with an NEC Electronics sales representative for availability and additional information.

ABSOLUTE MAXIMUM RATINGS (T_A = +25°C, unless otherwise specified)

Parameter	Symbol	Ratings	Unit
Drain to Source Voltage	V _{DS}	65	V
Gate to Source Voltage	V _{GS}	±7	V
Drain Current	I _D	12	A
Total Device Dissipation	P _{tot}	318	W
Channel Temperature	T _{ch}	200	°C
Storage Temperature	T _{stg}	-65 to +150	°C

THERMAL RESISTANCE (T_A = +25°C)

Parameter	Symbol	Test Conditions	MIN.	TYP.	MAX.	Unit
Thermal Resistance (Channel to case)	R _{th (ch-c)}		-	0.48	0.55	°C/W

RECOMMENDED OPERATING RANGE

Parameter	Symbol	MIN.	TYP.	MAX.	Unit
Drain to Source Voltage	V _{DS}	-	28	32	V
Gate to Source Voltage	V _{GS}	1.9	2.4	2.9	V
Average Input Power	P _{in (ave.)}	-	28	35	dBm

Not recommended for new design

ELECTRICAL CHARACTERISTICS (T_A = +25°C)

Parameter	Symbol	Test Conditions	MIN.	TYP.	MAX.	Unit
DC Characteristics						
Gate to Source Leak Current	I _{GSS}	V _{GSS} = 5 V	–	–	1	μA
Drain to Source Leakage Current (Zero Gate Voltage Drain Current)	I _{DSS}	V _{DSS} = 65 V	–	–	1	mA
Gate Threshold Voltage	V _{th}	V _{DS} = 10 V, I _{DS} = 1 mA	1.1	1.6	2.1	V
Transconductance	g _m	V _{DS} = 8.1 V, I _{DS} = 2±0.1 A	–	5.0	–	S
Drain to Source Breakdown Voltage	BV _{DSS}	I _{DSS} = 200 μA	65	75	–	V
RF Characteristics						
Output Power	P _{out}	f = 860 to 880 MHz, P _{in} = 35 dBm,	51.8	52.3	–	dBm
Gain 1 dB Compression Output Power	P _{O(1 dB)}	V _{DS} = 28 V, I _{Dset} = 1 200 mA	–	52.0	–	dBm
Drain Efficiency	η _d		52	60	–	%
Power Added Efficiency	η _{add}		–	59	–	%
Linear Gain	G _L ^{Note}		18.0	19.5	–	dB
3rd Order Intermodulation Distortion	IM ₃		f = 880/880.1 MHz, V _{DS} = 28 V, I _{Dset} = 1 200 mA, 2 tones P _{out} = 46.5 dBm	–	–40	–
Output Power	P _{out}	f = 920 to 960 MHz, P _{in} = 35 dBm,	–	52.2	–	dBm
Gain 1 dB Compression Output Power	P _{O(1 dB)}	V _{DS} = 28 V, I _{Dset} = 1 200 mA	–	51.9	–	dBm
Drain Efficiency	η _d		–	58	–	%
Power Added Efficiency	η _{add}		–	57	–	%
Linear Gain	G _L ^{Note}		–	19.0	–	dB
3rd Order Intermodulation Distortion	IM ₃		f = 960/960.1 MHz, V _{DS} = 28 V, I _{Dset} = 1 200 mA, 2 tones P _{out} = 46 dBm	–	–40	–

Note P_{in} = 28 dBm

TYPICAL CHARACTERISTICS ($T_A = +25^\circ\text{C}$, $V_{DS} = 28\text{ V}$, $I_{Dset} = 1\ 200\text{ mA}$, unless otherwise specified)

OUTPUT POWER, LINEAR GAIN, DRAIN EFFICIENCY vs. INPUT POWER

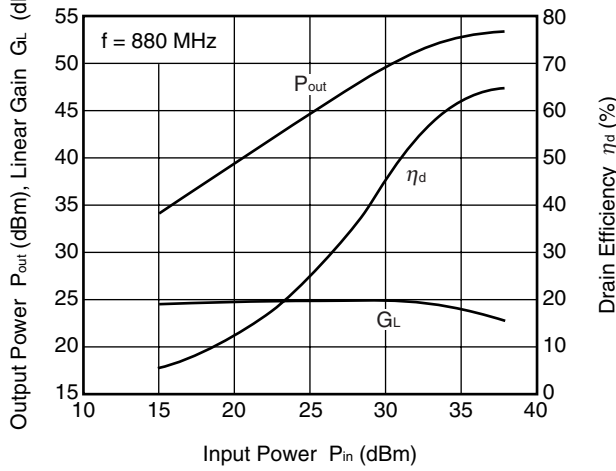

IM₃/IM₅ vs. 2 TONES OUTPUT POWER

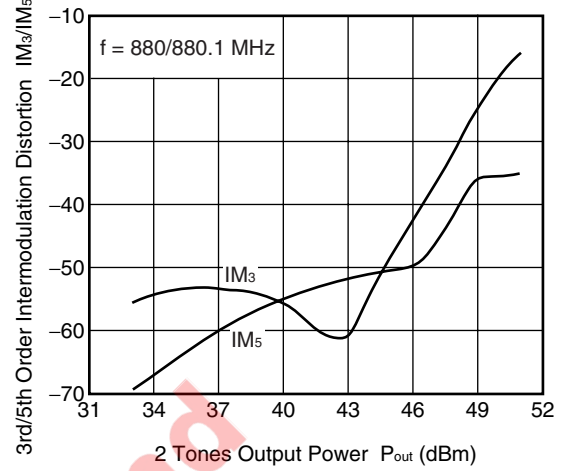

OUTPUT POWER, LINEAR GAIN, DRAIN EFFICIENCY vs. INPUT POWER

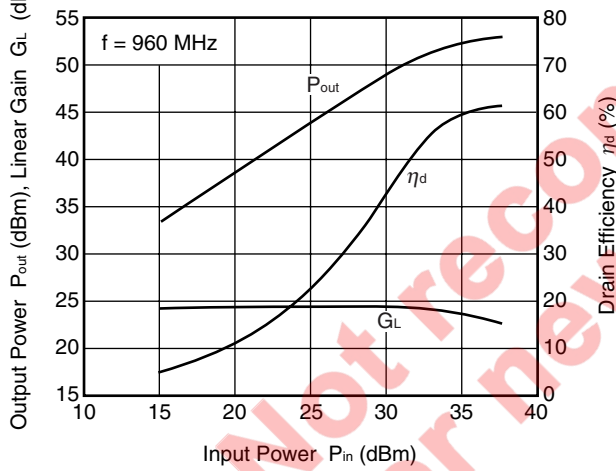

IM₃/IM₅ vs. 2 TONES OUTPUT POWER

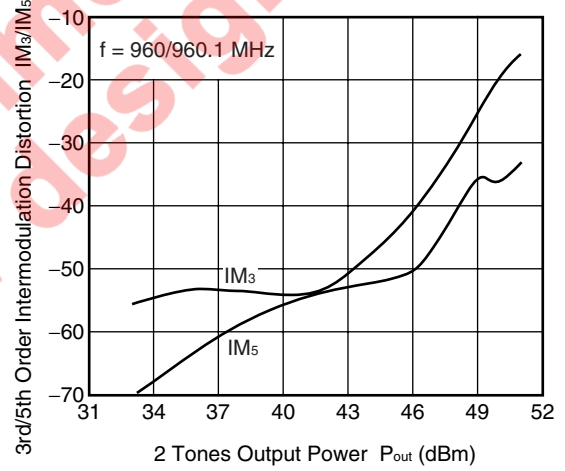

Remark The graphs indicate nominal characteristics.

COMPONENT LAYOUT OF TEST CIRCUIT FOR 860 TO 880 MHz

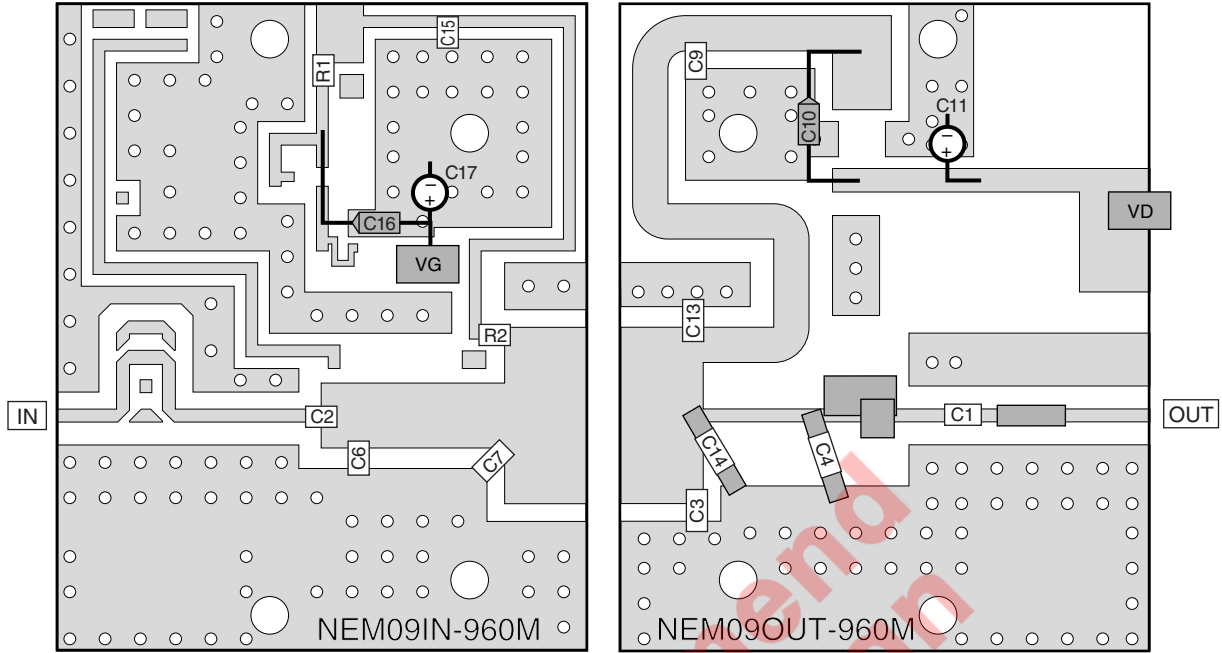

TEST CIRCUIT SCHMATIC FOR 860 TO 880 MHz

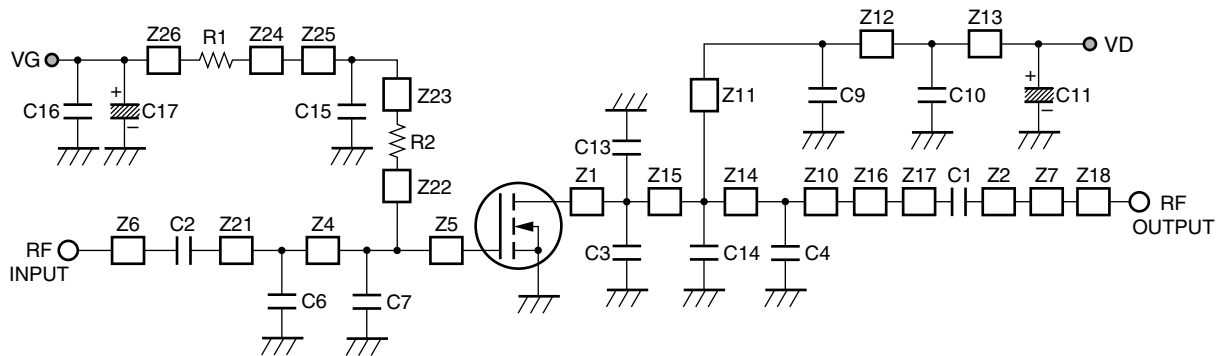

Symbol	Value	Symbol	Value
C1, C2	30 pF Chip Capacitor	Z25	Line, 1 × 6 mm
C4, C6	4 pF Chip Capacitor	Z24	Line, 5 × 4 mm
C7	7 pF Chip Capacitor	Z26	Line, 1 × 7 mm
C3, C14	8 pF Chip Capacitor	Z1	Line, 15 × 6 mm
C13	9 pF Chip Capacitor	Z15	Line, 15 × 1 mm
C9, C15	0.1 μF Chip Capacitor	Z14	Line, 1.1 × 10 mm
C10, C16	1 000 pF Feed-through Capacitor	Z10	Line, 2.5 × 2.5 mm
C11, C17	47 μF Electrolytic Capacitor	Z16	Line, 4.5 × 2.5 mm
R1	100 Ω Chip Resistor	Z17	Line, 1.1 × 6 mm
R2	10 Ω Chip Resistor	Z2	Line, 1.1 × 1 mm
Z6	Line, 1.1 × 30.7 mm	Z7	Line, 1.8 × 5 mm
Z21	Line, 5.5 × 2.6 mm	Z18	Line, 1.1 × 8 mm
Z4	Line, 5.5 × 13 mm	Z11	Line, 3 × 46 mm
Z5	Line, 15 × 7 mm	Z12	Line, 3 × 15 mm
Z22	Line, 1 × 1 mm	Z13	Line, 10 × 2 mm
Z23	Line, 1 × 45 mm	Circuit Board	Rogers 4350, $\epsilon_r = 3.55$, Thickness 0.51 mm

S-PARAMETERS

S-parameters/Noise parameters are provided on our web site in a form (S2P) that enables direct import to a microwave circuit simulator without keyboard input.

Click here to download S-parameters.

[RF and Microwave] → [Device Parameters]

URL <http://www.ncsd.necel.com/microwave/index.html>

PACKAGE DIMENSIONS

T-97M (3P) (UNIT: mm)

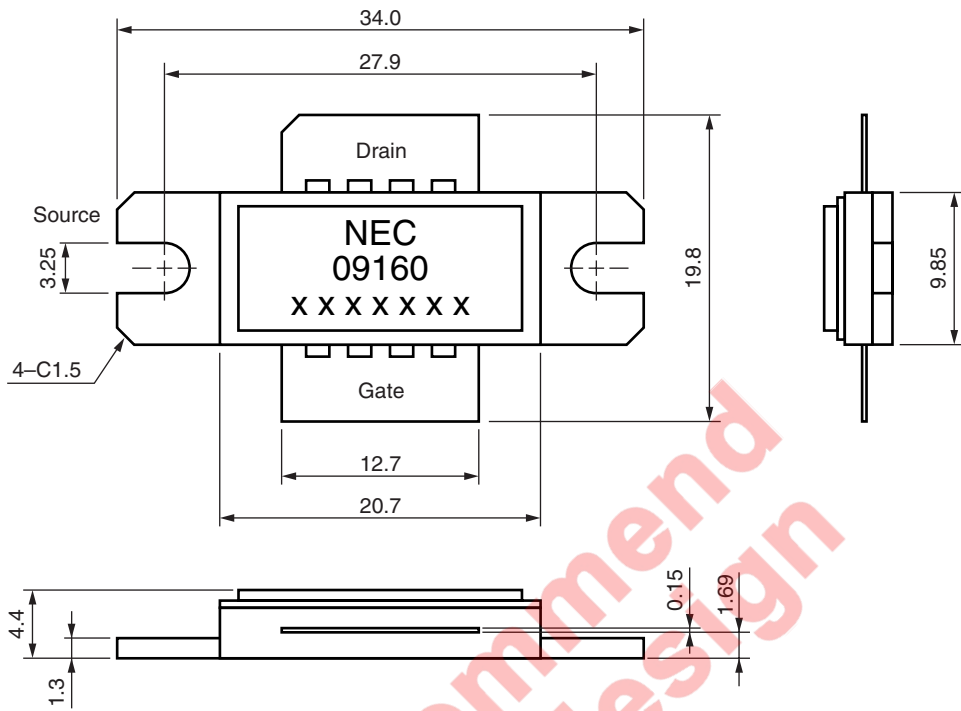

Not recommend for new design

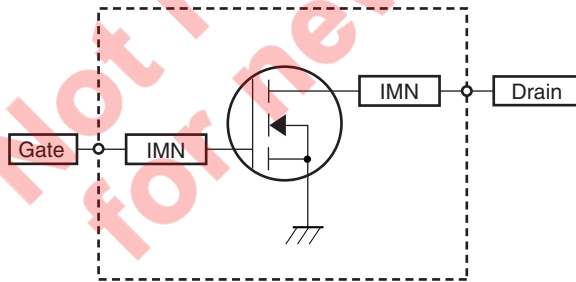

IMN : Internal Matching Network

RECOMMENDED MOUNTING CONDITIONS FOR CORRECT USE

- (1) Fix to a heat sink or mount surface completely with screws at the two holes of the flange.
- (2) The recommended torque strength of the screws is 53 N-cm typical using M3 type screws.
- (3) The recommended flatness of the mount surface is less than $\pm 10 \mu\text{m}$ (roughness of surface is $\nabla\nabla\nabla$).

RECOMMENDED SOLDERING CONDITIONS

This product should be soldered and mounted under the following recommended conditions. For soldering methods and conditions other than those recommended below, contact your nearby sales office.

Soldering Method	Soldering Conditions	Condition Symbol
Partial Heating	Peak temperature (terminal temperature) : 350°C or below Soldering time (per terminal of device) : 3 seconds or less Maximum chlorine content of rosin flux (% mass) : 0.2%(Wt.) or below	HS350-P3

Caution Do not use different soldering methods together (except for partial heating).

Not recommended
 for new design

• **The information in this document is current as of January, 2008. The information is subject to change without notice. For actual design-in, refer to the latest publications of NEC Electronics data sheets or data books, etc., for the most up-to-date specifications of NEC Electronics products. Not all products and/or types are available in every country. Please check with an NEC Electronics sales representative for availability and additional information.**

- No part of this document may be copied or reproduced in any form or by any means without the prior written consent of NEC Electronics. NEC Electronics assumes no responsibility for any errors that may appear in this document.
- NEC Electronics does not assume any liability for infringement of patents, copyrights or other intellectual property rights of third parties by or arising from the use of NEC Electronics products listed in this document or any other liability arising from the use of such products. No license, express, implied or otherwise, is granted under any patents, copyrights or other intellectual property rights of NEC Electronics or others.
- Descriptions of circuits, software and other related information in this document are provided for illustrative purposes in semiconductor product operation and application examples. The incorporation of these circuits, software and information in the design of a customer's equipment shall be done under the full responsibility of the customer. NEC Electronics assumes no responsibility for any losses incurred by customers or third parties arising from the use of these circuits, software and information.
- While NEC Electronics endeavors to enhance the quality, reliability and safety of NEC Electronics products, customers agree and acknowledge that the possibility of defects thereof cannot be eliminated entirely. To minimize risks of damage to property or injury (including death) to persons arising from defects in NEC Electronics products, customers must incorporate sufficient safety measures in their design, such as redundancy, fire-containment and anti-failure features.
- NEC Electronics products are classified into the following three quality grades: "Standard", "Special" and "Specific".

The "Specific" quality grade applies only to NEC Electronics products developed based on a customer-designated "quality assurance program" for a specific application. The recommended applications of an NEC Electronics product depend on its quality grade, as indicated below. Customers must check the quality grade of each NEC Electronics product before using it in a particular application.

"Standard": Computers, office equipment, communications equipment, test and measurement equipment, audio and visual equipment, home electronic appliances, machine tools, personal electronic equipment and industrial robots.

"Special": Transportation equipment (automobiles, trains, ships, etc.), traffic control systems, anti-disaster systems, anti-crime systems, safety equipment and medical equipment (not specifically designed for life support).

"Specific": Aircraft, aerospace equipment, submersible repeaters, nuclear reactor control systems, life support systems and medical equipment for life support, etc.

The quality grade of NEC Electronics products is "Standard" unless otherwise expressly specified in NEC Electronics data sheets or data books, etc. If customers wish to use NEC Electronics products in applications not intended by NEC Electronics, they must contact an NEC Electronics sales representative in advance to determine NEC Electronics' willingness to support a given application.

(Note)

- (1) "NEC Electronics" as used in this statement means NEC Electronics Corporation and also includes its majority-owned subsidiaries.
- (2) "NEC Electronics products" means any product developed or manufactured by or for NEC Electronics (as defined above).