

TTSV02622 STS-24 Backplane Transceiver

Features

- Allows wide range of applications for SONET network termination application as well as generic data moving for high-speed backplane data transfer.
- Clock/data recovery (CDR) function for high-speed serial backplane data transfer.
- CDR function uses Agere Systems Inc. proven 622 Mbits/s serial interface core.
- Two-channel CDR function provides 622 Mbits/s serial interface per channel for a total chip bandwidth of 1.24 Gbits/s (full duplex).
- Low-voltage differential signaling (LVDS) I/Os for CDR and reference clock signals.
- 8:1 data multiplexing/demultiplexing (MUX/deMUX) for 77.76 MHz byte-wide data processing.
- CDR meets B jitter tolerance specification of ITU-T recommendation G.958.
- Powerdown option of CDR receiver on a per-channel basis.
- Pseudo-SONET protocol including A1/A2 framing.
- SONET scrambling and descrambling for required ones density (optional).
- Selected transport overhead (TOH) bytes insertion and detection for interdevice communication via the TOH serial link.
- Streamlined pointer processor (pointer mover) for 8 kHz frame alignment.
- FIFOs for alignment of incoming data to reference clock.
- FIFOs optionally align incoming data across all two channels for synchronous transport signal STS-24 operation (in dual STS-12 format).
- Independent data stream enables in pseudo-SONET processor.
- Supports STS-12/STS-24 redundancy by either software or hardware control for protection switching applications.

- Low-power 3.3 V supply.
- $-40\text{ }^{\circ}\text{C}$ to $+125\text{ }^{\circ}\text{C}$ industrial temperature range.
- 272-pin ball grid array (PBGA) package.

Description

The TTSV02622 can support a 1.24 Gbits/s interface for backplane connections. The 1.24 Gbits/s interface is implemented as dual 622 Mbits/s LVDS links. The HSI macrocell is used for clock/data recovery (CDR) and MUX/deMUX between 77.76 MHz byte-wide internal data buses and the 622 Mbits/s external serial links.

Each 622 Mbits/s serial link uses a pseudo-SONET protocol. SONET A1/A2 framing is used on the link for locating the 8 kHz frame location. The link is also scrambled using the standard SONET scrambler definition to ensure proper transitions on the link for improved CDR performance. Selectable transport overhead (TOH) bytes are insertable in the transmit direction. All bytes can be transparently passed through the device, or all bytes can be inserted via the TOH serial link. In addition, certain microprocessor unit (MPU) selectable bytes can be passed through transparently while in insert mode.

Elastic buffers (FIFOs) are used to align each incoming STS-12 link to the core 77.76 MHz clock and 8 kHz frame. These FIFOs will absorb delay variations between 622 Mbits/s links due to timing skews between cards and along backplane traces. For greater variations, a streamlined pointer processor (pointer mover) within the device will align the 8 kHz frames regardless of their incoming frame position.

The TTSV02622 supports dual STS-12 mode of operation on the input/output ports. STS-24 is also supported, but it must be received in the dual STS-12 format. When operating in dual STS-12 mode, each of the independent byte streams carries an entire STS-12 within it. Figure 1 on page 2 reveals the byte ordering of the individual STS-12 streams.

Description (continued)

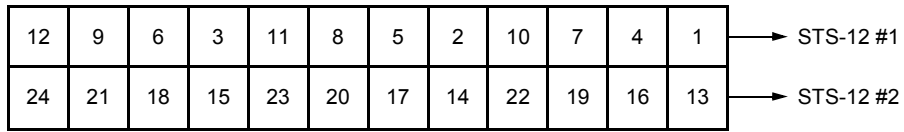

STS-24 IN DUAL STS-12 FORMAT

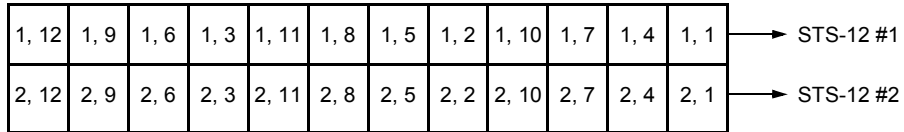

DUAL STS-12

Figure 1. Byte Ordering on Input/Output Interface in STS-12 Mode

Table of Contents

Contents	Page
Features	1
Description.....	1
Pin Information	6
Synchronization	17
HSI Block Interface.....	17
Line Interface.....	17
Architecture	17
Powerdown Mode.....	19
Supervisory Features	20
Test Features	21
Transmit Direction (Line to Backplane)	22
Transport Overhead Serial Link.....	23
A1/A2 Frame Insert and Corruption	23
B1 Calculation and Insertion	23
Stream Disable	23
Scrambler.....	23
Receiver Block.....	24
Framer Subblock (Backplane to Line).....	24
B1 Calculate and Descramble (Backplane to Line)	27
Internal Parity Generation	27
FIFO Subblock (Backplane to Line).....	28
Pointer Mover Subblock (Backplane to Line).....	28
Miscellaneous Functions	31
K1/K2, A1/A2 Handling	31
SPE C1J1 Outputs.....	31
Registers	32
Definition of Register Types.....	32
Register Map.....	33
Register Descriptions	36
Absolute Maximum Ratings.....	48
Handling Precautions	48
Recommended Operating Conditions	48
Thermal Characteristics.....	49
Power Consumption (Advance).....	49
Electrical Characteristics	49
Propagation Delay Specifications.....	49
LVDS I/O	50
LVDS Receiver Buffer Capabilities	52
Clock and Data Recovery (CDR).....	54
Input Data	54
Jitter Tolerance	54
Generated Output Jitter	54
PLL.....	54
Input Reference Clock	54
Timing Characteristics	55
CPU Interface Timing.....	61
Outline Diagram.....	63
272-Pin PBGA.....	63
Ordering Information.....	64

List of Figures

Contents	Page
Figure 1. Byte Ordering on Input/Output Interface in STS-12 Mode	2
Figure 2. Pin Diagram of 272-Pin PBGA (Bottom View).....	6
Figure 3. Suggested Schematic for 1.0 V and 1.4 V Reference Voltages	16
Figure 4. Alignment of Two STS-12 Streams	17
Figure 5. Interior View of TTSV02622	18
Figure 6. Interconnect of Streams for FIFO Alignment.....	19
Figure 7. Transmitter Block	22
Figure 8. Receiver Block	24
Figure 9. Framing State Machine.....	26
Figure 10. Pointer Mover State Machine	30
Figure 11. LVDS Driver and Receiver and Associated Internal Components	51
Figure 12. LVDS Driver and Receiver	51
Figure 13. LVDS Driver	51
Figure 14. Input Parallel Port Timing	55
Figure 15. Transmitter Transport Delay.....	56
Figure 16. Output Parallel Port Timing	57
Figure 17. Protection Switch Timing.....	58
Figure 18. Input Serial Port Timing.....	59
Figure 19. Output Serial Port Timing	60
Figure 20. Write Transaction	61
Figure 21. Read Transaction	62

List of Tables

Contents	Page
Table 1. Pin Assignments for 272-Pin PBGA by Pin Number Order	7
Table 2. Pin Assignments for 272-Pin PBGA by Signal Name	10
Table 3. Pin Descriptions	12
Table 4. Valid Starting Positions for a STS-MC.....	29
Table 5. SPE and C1J1 Functionality	31
Table 6. Register Map	33
Table 7. Register Description	36
Table 8. Absolute Maximum Ratings	48
Table 9. Handling Precautions	48
Table 10. Recommended Operating Conditions	48
Table 11. Thermal Resistance—Junction to Ambient	49
Table 12. Power Consumption (Advance).....	49
Table 13. LVTTTL Electrical Characteristics	49
Table 14. LVDS Receiver dc Data*	52
Table 15. LVDS Receiver ac Data*	52
Table 16. LVDS Driver dc Data*	53
Table 17. LVDS Driver ac Data*	53
Table 18. LVDS Driver Reference Data	53
Table 19. Jitter Tolerance	54
Table 20. Input Parallel Port Timing Requirements	55
Table 21. Transmitter Transport Delay Timing Requirements.....	56
Table 22. Output Parallel Port Timing Requirements	57
Table 23. Protection Switch Timing Requirements.....	58
Table 24. Input Serial Port Timing Requirements.....	59
Table 25. Output Serial Port Timing Requirements	60
Table 26. Write Transaction Timing Requirements	61
Table 27. Read Transaction Timing Requirements	62

Pin Information

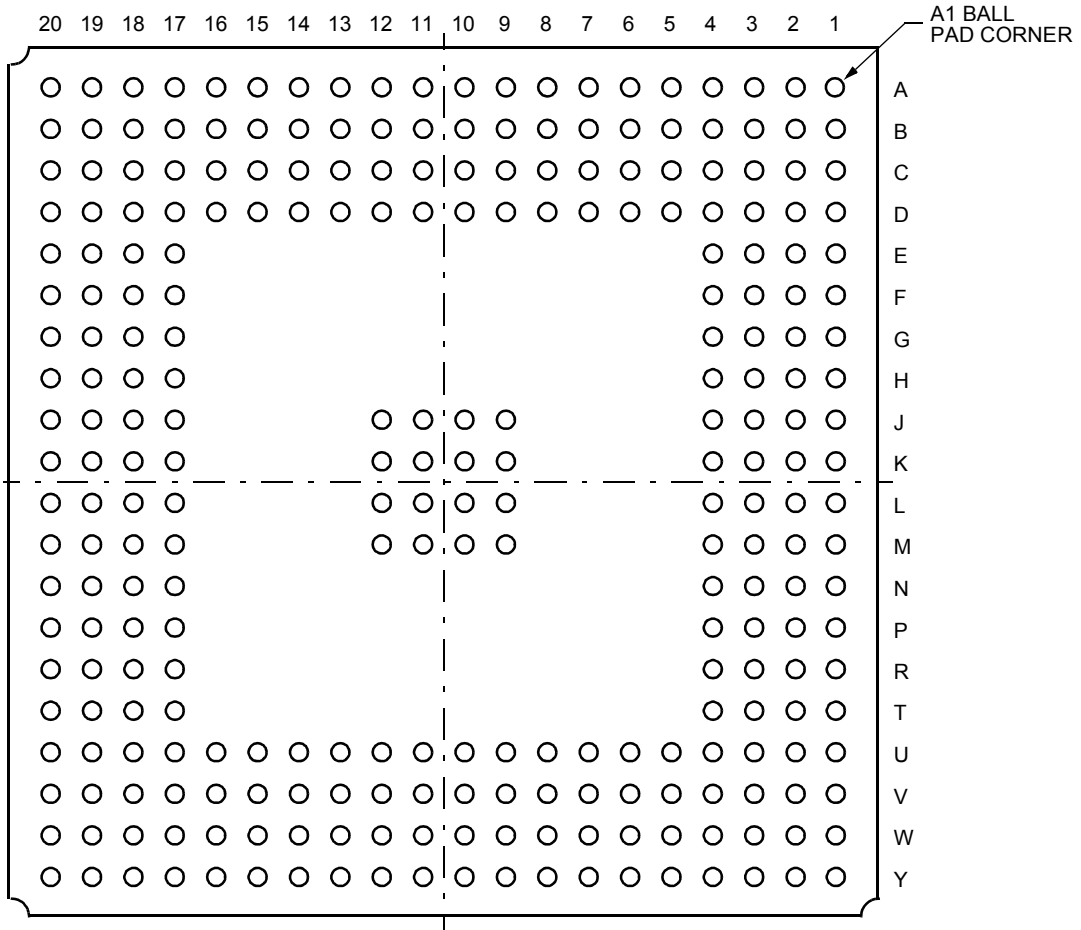

Figure 2. Pin Diagram of 272-Pin PBGA (Bottom View)

Pin Information (continued)

Table 1. Pin Assignments for 272-Pin PBGA by Pin Number Order

Pin	Signal Name	Pin	Signal Name	Pin	Signal Name	Pin	Signal Name
A1	Vss	B1	TDO	C1	NC	D1	NC
A2	TCK	B2	TRSTN	C2	NC	D2	NC
A3	TDI	B3	TSTMD	C3	LVDS_EN	D3	NC
A4	TMS	B4	SCANEN	C4	NC	D4	Vss
A5	DXP	B5	NC	C5	NC	D5	NC
A6	NC	B6	DXN	C6	NC	D6	VDD
A7	PROT_SWITCH_A	B7	PROT_SWITCH_C	C7	NC	D7	NC
A8	TOH_INA	B8	TOH_INB	C8	TX_TOH_CKEN	D8	Vss
A9	NC	B9	NC	C9	TOH_CLK	D9	NC
A10	NC	B10	NC	C10	NC	D10	NC
A11	TOH_OUTA	B11	TOH_OUTB	C11	RX_TOH_CKEN	D11	VDD
A12	NC	B12	NC	C12	RX_TOH_FP	D12	NC
A13	NC	B13	NC	C13	NC	D13	Vss
A14	NC	B14	NC	C14	NC	D14	NC
A15	DOUTA7	B15	DOUTA6	C15	DOUTA5	D15	VDD
A16	DOUTA4	B16	DOUTA3	C16	DOUTA2	D16	DOUTA1
A17	DOUTA0	B17	DOUTA_PAR	C17	DOUTA_SPE	D17	Vss
A18	DOUTA_C1J1	B18	DOUTB5	C18	DOUTB2	D18	DOUTB_PAR
A19	DOUTB7	B19	DOUTB4	C19	DOUTB1	D19	DOUTB_SPE
A20	DOUTB6	B20	DOUTB3	C20	DOUTB0	D20	DOUTB_C1J1

Note: NC refers to no connect. Do not connect pins so designated.

Pin Information (continued)**Table 1. Pin Assignments for 272-Pin PBGA by Pin Number Order** (continued)

Pin	Signal Name	Pin	Signal Name	Pin	Signal Name	Pin	Signal Name
E1	STS_INA_P	H17	Vss	L1	STS_OUTB_P	N17	Vss
E2	STS_INA_N	H18	NC	L2	STS_OUTB_N	N18	DINA7
E3	CTAP_REFA	H19	NC	L3	NC	N19	DINA6
E4	NC	H20	NC	L4	NC	N20	DINA5
E17	NC	J1	STS_OUTA_P	L9	Vss	P1	NC
E18	NC	J2	STS_OUTA_N	L10	Vss	P2	NC
E19	NC	J3	NC	L11	Vss	P3	NC
E20	NC	J4	NC	L12	Vss	P4	NC
F1	STS_INB_P	J9	Vss	L17	VDD	P17	DINA4
F2	STS_INB_N	J10	Vss	L18	NC	P18	DINA3
F3	CTAP_REFB	J11	Vss	L19	NC	P19	DINA2
F4	VDD	J12	Vss	L20	NC	P20	DINA1
F17	VDD	J17	NC	M1	REF10	R1	NC
F18	NC	J18	NC	M2	REF14	R2	NC
F19	NC	J19	NC	M3	LVDS_RESB	R3	NC
F20	NC	J20	NC	M4	LVDS_RESB	R4	VDD
G1	NC	K1	PLL REF	M9	Vss	R17	VDD
G2	NC	K2	PLL_VDDA	M10	Vss	R18	DINB7
G3	NC	K3	PLL_VSSA	M11	Vss	R19	DINA0
G4	NC	K4	VDD	M12	Vss	R20	DINA_PAR
G17	NC	K9	Vss	M17	SYS_CLK	T1	TSTMODE
G18	NC	K10	Vss	M18	SYS_FP	T2	BYPASS
G19	NC	K11	Vss	M19	LINE_FP	T3	RESETRN
G20	NC	K12	Vss	M20	NC	T4	RESETTN
H1	NC	K17	NC	N1	NC	T17	DINB6
H2	NC	K18	NC	N2	NC	T18	DINB5
H3	NC	K19	NC	N3	NC	T19	DINB4
H4	Vss	K20	NC	N4	Vss	T20	DINB3

Note: NC refers to no connect. Do not connect pins so designated.

Pin Information (continued)

Table 1. Pin Assignments for 272-Pin PBGA by Pin Number Order (continued)

Pin	Signal Name	Pin	Signal Name	Pin	Signal Name	Pin	Signal Name
U1	TSTCLK	V1	MRESET	W1	EXDNUP	Y1	NC
U2	TSTSHFTLD	V2	ECSEL	W2	TSTPHASE	Y2	NC
U3	ETOGGLE	V3	LOOPBKEN	W3	TSTMUX8S	Y3	TSTMUX7S
U4	Vss	V4	TSTMUX6S	W4	TSTMUX5S	Y4	TSTMUX4S
U5	TSTMUX3S	V5	TSTMUX2S	W5	TSTMUX1S	Y5	TSTMUX0S
U6	VDD	V6	NC	W6	NC	Y6	NC
U7	CPU_ADDR6	V7	CPU_ADDR5	W7	CPU_ADDR4	Y7	CPU_ADDR3
U8	Vss	V8	CPU_ADDR2	W8	CPU_ADDR1	Y8	CPU_ADDR0
U9	CS_N	V9	RD_WRN	W9	RST_N	Y9	HIZ_N
U10	VDD	V10	INT_N	W10	NC	Y10	NC
U11	CPU_DATA7	V11	CPU_DATA6	W11	CPU_DATA5	Y11	CPU_DATA4
U12	CPU_DATA3	V12	CPU_DATA2	W12	CPU_DATA1	Y12	CPU_DATA0
U13	Vss	V13	NC	W13	NC	Y13	NC
U14	NC	V14	NC	W14	NC	Y14	NC
U15	VDD	V15	NC	W15	NC	Y15	NC
U16	DIND4	V16	NC	W16	NC	Y16	NC
U17	Vss	V17	NC	W17	NC	Y17	NC
U18	DINB2	V18	NC	W18	NC	Y18	NC
U19	DINB1	V19	NC	W19	NC	Y19	NC
U20	DINB0	V20	DINB_PAR	W20	NC	Y20	NC

Note: NC refers to no connect. Do not connect pins so designated.

Pin Information (continued)

Table 2. Pin Assignments for 272-Pin PBGA by Signal Name

Signal Name	Pin	Signal Name	Pin	Signal Name	Pin	Signal Name	Pin
BYPASS	T2	DINB4	T19	LINE_FP	M19	NC	D12
CPU_ADDR0	Y8	DINB5	T18	LOOPBKEN	V3	NC	D14
CPU_ADDR1	W8	DINB6	T17	LVDS_EN	C3	NC	E4
CPU_ADDR2	V8	DINB7	R18	LVDS_RESB	M3	NC	E17
CPU_ADDR3	Y7	DIND4	U16	LVDS_RESL	M4	NC	E18
CPU_ADDR4	W7	DOUTA_C1J1	A18	MRESET	V1	NC	E19
CPU_ADDR5	V7	DOUTA_PAR	B17	NC	A6	NC	E20
CPU_ADDR6	U7	DOUTA_SPE	C17	NC	A9	NC	F18
CPU_DATA0	Y12	DOUTA0	A17	NC	A10	NC	F19
CPU_DATA1	W12	DOUTA1	D16	NC	A12	NC	F20
CPU_DATA2	V12	DOUTA2	C16	NC	A13	NC	G1
CPU_DATA3	U12	DOUTA3	B16	NC	A14	NC	G2
CPU_DATA4	Y11	DOUTA4	A16	NC	B5	NC	G3
CPU_DATA5	W11	DOUTA5	C15	NC	B9	NC	G4
CPU_DATA6	V11	DOUTA6	B15	NC	B10	NC	G17
CPU_DATA7	U11	DOUTA7	A15	NC	B12	NC	G18
CS_N	U9	DOUTB_C1J1	D20	NC	B13	NC	G19
CTAP_REFA	E3	DOUTB_PAR	D18	NC	B14	NC	G20
CTAP_REFB	F3	DOUTB_SPE	D19	NC	C1	NC	H1
DINA_PAR	R20	DOUTB0	C20	NC	C2	NC	H2
DINA0	R19	DOUTB1	C19	NC	C4	NC	H3
DINA1	P20	DOUTB2	C18	NC	C5	NC	H18
DINA2	P19	DOUTB3	B20	NC	C6	NC	H19
DINA3	P18	DOUTB4	B19	NC	C7	NC	H20
DINA4	P17	DOUTB5	B18	NC	C10	NC	J3
DINA5	N20	DOUTB6	A20	NC	C13	NC	J4
DINA6	N19	DOUTB7	A19	NC	C14	NC	J17
DINA7	N18	DXN	B6	NC	D1	NC	J18
DINB_PAR	V20	DXP	A5	NC	D2	NC	J19
DINB0	U20	ECSEL	V2	NC	D3	NC	J20
DINB1	U19	ETOGGLE	U3	NC	D5	NC	K17
DINB2	U18	EXDNUP	W1	NC	D7	NC	K18
DINB3	T20	HIZ_N	Y9	NC	D9	NC	K19
DINB3	T20	INT_N	V10	NC	D10	NC	K20

Note: NC refers to no connect. Do not connect pins so designated.

Pin Information (continued)

Table 2. Pin Assignments for 272-Pin PBGA by Signal Name (continued)

Signal Name	Pin	Signal Name	Pin	Signal Name	Pin	Signal Name	Pin
NC	L3	NC	W20	STS_OUTB_P	L1	VDD	L17
NC	L4	NC	Y1	SYS_CLK	M17	VDD	R4
NC	L18	NC	Y2	SYS_FP	M18	VDD	R17
NC	L19	NC	Y6	TCK	A2	VDD	U6
NC	L20	NC	Y10	TDI	A3	VDD	U10
NC	M20	NC	Y13	TDO	B1	VDD	U15
NC	N1	NC	Y14	TMS	A4	VSS	A1
NC	N2	NC	Y15	TOH_CLK	C9	VSS	D4
NC	N3	NC	Y16	TOH_INA	A8	VSS	D8
NC	P1	NC	Y17	TOH_INB	B8	VSS	D13
NC	P2	NC	Y18	TOH_OUTA	A11	VSS	D17
NC	P3	NC	Y19	TOH_OUTB	B11	VSS	H4
NC	P4	NC	Y20	TRSTN	B2	VSS	H17
NC	R1	PLL REF	K1	TSTCLK	U1	VSS	J9
NC	R2	PLL_VDDA	K2	TSTMD	B3	VSS	J10
NC	R3	PLL_VSSA	K3	TSTMODE	T1	VSS	J11
NC	U14	PROT_SWITCH_A	A7	TSTMUX0S	Y5	VSS	J12
NC	V6	PROT_SWITCH_C	B7	TSTMUX1S	W5	VSS	K9
NC	V13	RD_WRN	V9	TSTMUX2S	V5	VSS	K10
NC	V14	REF10	M1	TSTMUX3S	U5	VSS	K11
NC	V15	REF14	M2	TSTMUX4S	Y4	VSS	K12
NC	V16	RESETRN	T3	TSTMUX5S	W4	VSS	L9
NC	V17	RESETTN	T4	TSTMUX6S	V4	VSS	L10
NC	V18	RST_N	W9	TSTMUX7S	Y3	VSS	L11
NC	V19	RX_TOH_CKEN	C11	TSTMUX8S	W3	VSS	L12
NC	W6	RX_TOH_FP	C12	TSTPHASE	W2	VSS	M9
NC	W10	SCANEN	B4	TSTSHFTLD	U2	VSS	M10
NC	W13	STS_INA_N	E2	TX_TOH_CKEN	C8	VSS	M11
NC	W14	STS_INA_P	E1	VDD	D6	VSS	M12
NC	W15	STS_INB_N	F2	VDD	D11	VSS	N4
NC	W16	STS_INB_P	F1	VDD	D15	VSS	N17
NC	W17	STS_OUTA_N	J2	VDD	F4	VSS	U4
NC	W18	STS_OUTA_P	J1	VDD	F17	VSS	U8
NC	W19	STS_OUTB_N	L2	VDD	K4	VSS	U13
—	—	—	—	—	—	VSS	U17

Note: NC refers to no connect. Do not connect pins so designated.

Pin Information (continued)**Table 3. Pin Descriptions**

Pin	Symbol	Type	I/O	Description
N18, N19, N20, P17, P18, P19, P20, R19	DINA[7:0]	TTL	I/ Pull-up	Input parallel bus of transmitter #1.
R20	DINA_PAR	TTL	I/ Pull-up	Parity for input bus of transmitter #1.
R18, T17, T18, T19, T20, U18, U19, U20	DINB[7:0]	TTL	I/ Pull-up	Input parallel bus of transmitter #2.
V20	DINB_PAR	TTL	I/ Pull-up	Parity for input bus of transmitter #2.
A15, B15, C15, A16, B16, C16, D16, A17	DOUTA[7:0]	TTL	O/ HI-Z/ Pull-up	Output parallel bus of receiver #1.
B17	DOUTA_PAR	TTL	O/ HI-Z/ Pull-up	Parity for output parallel bus of receiver #1.
C17	DOUTA_SPE	TTL	O/ HI-Z/ Pull-up	SPE signal for output parallel bus of receiver #1.
A18	DOUTA_C1J1	TTL	O/ HI-Z/ Pull-up	C1J1 signal for output parallel bus of receiver #1.
A19, A20, B18, B19, B20, C18, C19, C20	DOUTB[7:0]	TTL	O/ HI-Z/ Pull-up	Output parallel bus of receiver #2.
D18	DOUTB_PAR	TTL	O/ HI-Z/ Pull-up	Parity for output parallel bus of receiver #2.
D19	DOUTB_SPE	TTL	O/ HI-Z/ Pull-up	SPE signal for output parallel bus of receiver #2.
D20	DOUTB_C1J1	TTL	O/ HI-Z/ Pull-up	C1J1 signal for output parallel bus of receiver #2.
C9	TOH_CLK	TTL	I/ Pull-up	Tx and Rx TOH serial links clock (25 MHz— 77.76 MHz).
A8	TOH_INA	TTL	I/ Pull-up	TOH serial link input for transmitter #1.
B8	TOH_INB	TTL	I/ Pull-up	TOH serial link input for transmitter #2.
C8	TX_TOH_CKEN	TTL	I/ Pull-up	Tx TOH serial link clock enable.
A11	TOH_OUTA	TTL	O/ HI-Z/ Pull-up	TOH serial link output for receiver #1.

Pin Information (continued)

Table 3. Pin Descriptions (continued)

Pin	Symbol	Type	I/O	Description
B11	TOH_OUTB	TTL	O/ HI-Z/ Pull-up	TOH serial link output for receiver #2.
C11	RX_TOH_CKEN	TTL	O/ HI-Z/ Pull-up	Rx TOH serial link clock enable.
C12	RX_TOH_FP	TTL	O/ HI-Z/ Pull-up	Rx TOH serial link frame pulse.
E1	STS_INA_P	LVDS	I	LVDS input receiver #1.
E2	STS_INA_N	LVDS	I	LVDS input receiver #1.
F1	STS_INB_P	LVDS	I	LVDS input receiver #2.
F2	STS_INB_N	LVDS	I	LVDS input receiver #2.
J1	STS_OUTA_P	LVDS	O	LVDS output transmitter #1.
J2	STS_OUTA_N	LVDS	O	LVDS output transmitter #1.
L1	STS_OUTB_P	LVDS	O	LVDS output transmitter #2.
L2	STS_OUTB_N	LVDS	O	LVDS output transmitter #2.
E3	CTAP_REFA	—	—	LVDS input center tap (Rx #1) (use 0.01 μ F to GND).
F3	CTAP_REFB	—	—	LVDS input center tap (Rx #2) (use 0.01 μ F to GND).
U11, V11, W11, Y11, U12, V12, W12, Y12	CPU_DATA[7:0]	TTL	I/ O/ Pull-up	Central processing unit (CPU) interface data bus.
U7, V7, W7, Y7, V8, W8, Y8	CPU_ADDR[6:0]	TTL	I/ Pull-up	CPU interface address bus.
V9	RD_WRN	TTL	I/Pull-Up	CPU interface read/write.
U9	CS_N	TTL	I/ Pull-up SCHMITT	Chip select.
M18	SYS_FP	TTL	I/ Pull-up	System frame pulse for transmitter section.
M19	LINE_FP	TTL	I/ Pull-up	Line frame pulse for receiver section.
M17	SYS_CLK	TTL	I/ Pull-up	System clock (77.76 MHz).
A7	PROT_SW_A	TTL	I/ Pull-up	Protection switching control signal.
B7	PROT_SW_C	TTL	I/ Pull-up	Protection switching control signal.
V10	INT_N	TTL	O/ Open Drain	Interrupt output.
W9	RST_N	TTL	I/ Pull-down/ SCHMITT	Global reset.

Pin Information (continued)

Table 3. Pin Descriptions (continued)

Pin	Symbol	Type	I/O	Description
Y9	HIZ_N	TTL	I/ Pull-up/ SCHMITT	Global 3-state control.
K1	PLL_REF	—	—	Reference for PLL (10 k Ω to GND).
M1	REF10	—	I	1.0 V reference for LVDS reference block. See Figure 3 on page 16.
M2	REF14	—	I	1.4 V reference for LVDS reference block. See Figure 3 on page 16.
M3	LVDS_RESB	—	—	Resistance high input (use 100 Ω to LVDS_RESB input).
M4	LVDS_RESL	—	—	Resistance low input (use 100 Ω to LVDS_RESB input).
A5	DXP	—	—	Temperature-sensing diode (anode +).
B6	DXN	—	—	Temperature-sensing diode (cathode –).
K2	PLL_VDDA	—	—	PLL analog VDD (3.3 V).
K3	PLL_VSSA	—	—	PLL analog VSS (GND).
A2	TCLK	TTL	I/ Pull-up	JTAG clock input.
A3	TDI	TTL	I/ Pull-up	JTAG data input.
A4	TMS	TTL	I/ Pull-up	JTAG mode select input.
B1	TDO	TTL	O	JTAG data output.
B2	TRSTN	TTL	I/ Pull-up	JTAG reset input.
B3	TSTMD	TTL	I/ Pull-up	Scan test mode input.
B4	SCANEN	TTL	I/ Pull-Up	Scan mode enable input.
C3	LVDS_EN	—	I/ Pull-up	LVDS enable used during boundary scan (B-S).
T1	TSTMODE	—	I/ Pull-down	Enables CDR test mode.
T2	BYPASS	—	I/ Pull-down	Enables bypassing of the 622 MHz clock synthesis with TSTCLK.
U1	TSTCLK	—	I/ Pull-down	Test clock for emulation of 622 MHz clock during PLL bypass.
V1	MRESET	—	I/ Pull-down	Test mode reset.
T3	RESETRN	—	I/ Pull-up	Resets receiver clock division counter.
T4	RESETTN	—	I/ Pull-up	Resets transmitter clock division counter.
U2	TSTSHFTLD	—	I/ Pull-down	Enables the test mode control register for shifting-in selected tests by a serial port.

Pin Information (continued)

Table 3. Pin Descriptions (continued)

Pin	Symbol	Type	I/O	Description
V2	ECSEL	—	I/ Pull-down	Enables external test control of 622 MHz clock phase selection.
W1	EXDNUP	—	I/ Pull-down	Direction of phase change.
U3	ETOGGLE	—	I/ Pull-down	Moves 622.08 MHz clock selection on phase per positive pulse.
V3	LOOPBKEN	—	I/ Pull-Down	Enables 622 Mbits/s loopback mode.
W2	TSTPHASE	—	I/ Pull-down	Controls bypass of 16 PLL-generated phases with 16 low-speed phases.
W3, Y3, V4, W4, Y4, U5, V5, W5, Y5	TSTMUX[8:0]S	—	O	Test mode output port.
A1, D4, D8, D13, D17, H4, H17, N4, N17, U4, U8, U13, U17, J9, J10, J11, J12, K9, K10, K11, K12, L9, L10, L11, L12, M9, M10, M11, M12	Vss	—	—	—
D6, D11, D15, F4, F17, K4, L17, R4, R17, U6, U10, U15	VDD	—	—	—

Pin Information (continued)

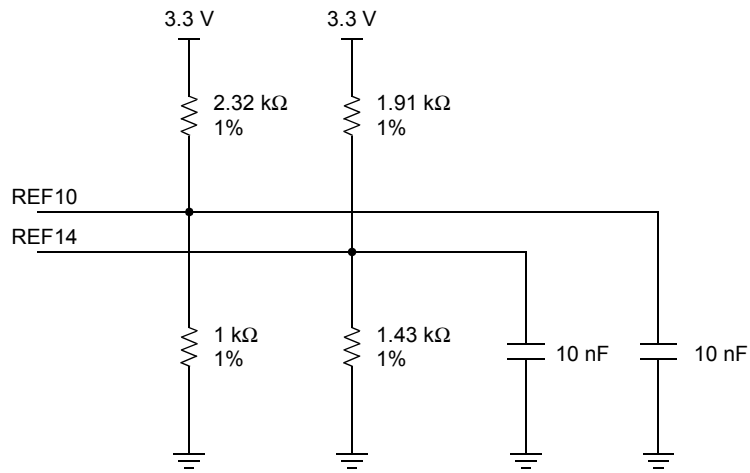

Figure 3. Suggested Schematic for 1.0 V and 1.4 V Reference Voltages

Synchronization

The incoming data from the high-speed interface (HSI) can be separated into two STS-12 channels per slice (A and B).

Example of TTSV02622 alignment.

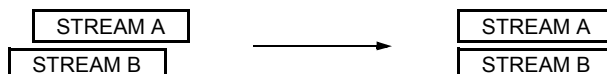

Figure 4. Alignment of Two STS-12 Streams

There is also a provision to allow certain streams to be disabled (i.e., not producing interrupts or affecting synchronization). These streams can be enabled at a later time without disrupting other streams.

HSI Block Interface

The HSI block should provide two independent 77.76 MHz interfaces. Each interface will consist of a byte-wide data stream and its recovered clock. There is no requirement for bit alignment since SONET type framing will take place inside the TTSV02622 device.

Line Interface

The line side will receive/transmit frame-aligned streams of STS-12 data. All frames transmitted to the line will be aligned to the line frame pulse, which will be provided to the TTSV02622. All frames received from the line will be aligned to the system frame pulse, which will be supplied to the TTSV02622.

Architecture

The TTSV02622 is composed of transmit (Tx) and receive (Rx) sections. The device (see Figure 1 on page 2) receives two byte-wide data streams at 77.76 MHz (STS-12 rate) and the associated clock. The incoming streams are framed, and descrambled before they are then written into a FIFO that absorbs phase and delay variations and allows the shift to system clock. The TOH is then extracted and sent out on the two serial ports. The pointer interpreter will then put the synchronous transport signal (STS) synchronous payload envelopes (SPEs) into a small elastic store from which the pointer generator will produce two byte-wide STS-12 streams of data that are aligned to the line timing pulse.

Architecture (continued)

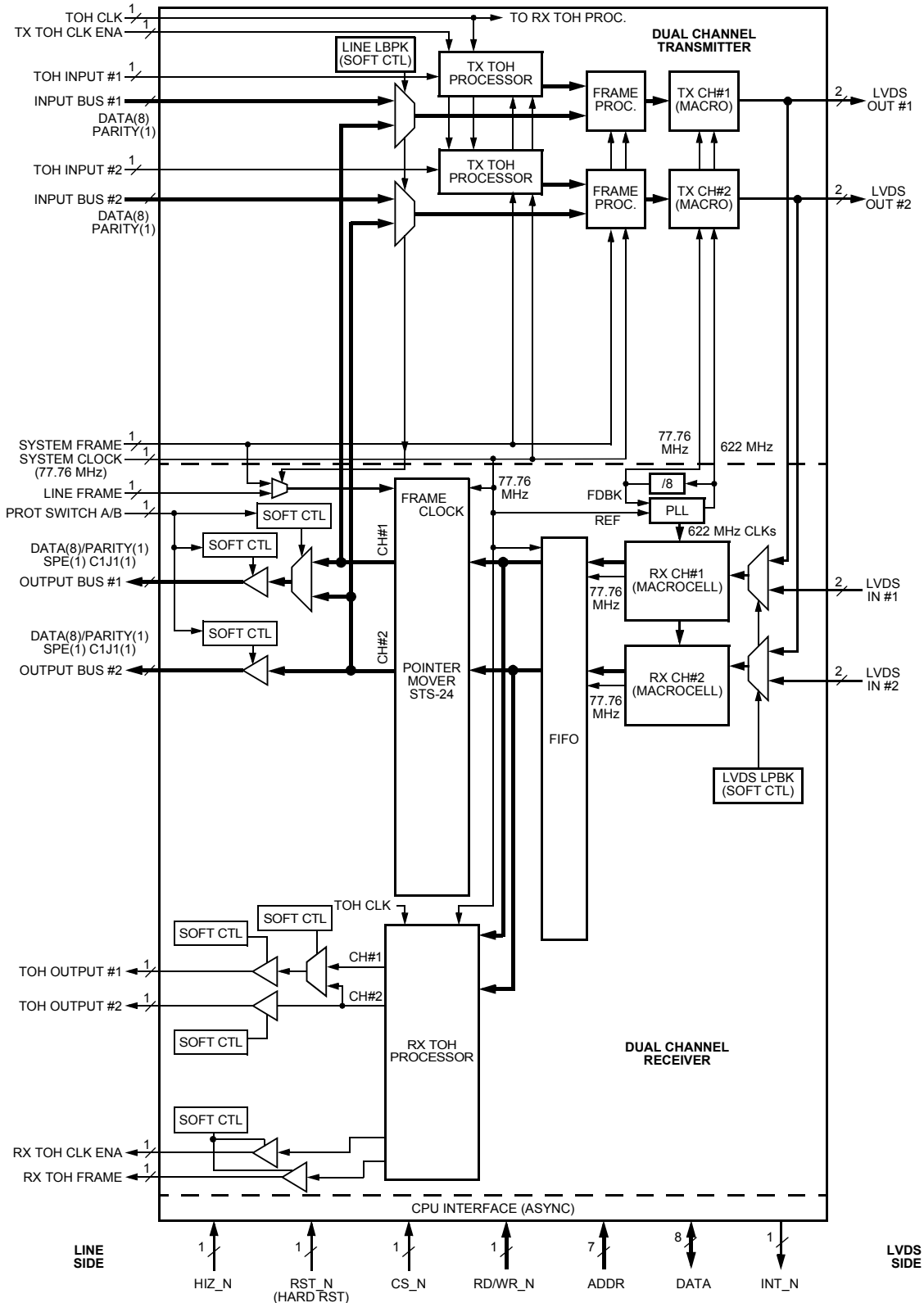

Figure 5. Interior View of TTSV02622

Architecture (continued)

The alignment FIFO allows the transfer of all data to the system clock. The FIFO sync block allows the system to be configured to allow the frame alignment of multiple slightly varying data streams (see the FIFO Sync Subblock (Backplane to Line) section on page 28).

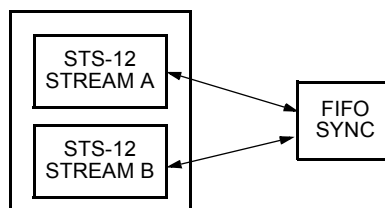

Figure 6. Interconnect of Streams for FIFO Alignment

The pointer mover (see the Pointer Mover Subblock (Backplane to Line) section on page 28) is responsible for mapping incoming frames to line frames. The pointer mover is a pseudo SONET implementation which is streamlined wherever possible to minimize gate count and complexity. As a result, it is only capable of correcting single bit, nonrepeating pointer errors. This pointer mover (i.e., interpreter, elastic store, and generator) will be capable of handling intra STS-12 concatenation as well as inter STS-12 concatenation as long as the STS-12 streams are frame aligned.

Powerdown Mode

Powerdown mode should be entered when the corresponding channel is disabled. Channels can be independently enabled or disabled under software control.

Note: The EXT PROT SW FUNC is low for STS-12 mode.

When a channel is disabled, the disabled channel of the clock and data recovery module is powered down, as well as the LVDS buffers and TTL buffers for that channel. When all channels are powered down, PLL in the CDR module is also powered down.

In addition, a pin has been added to enable the LVDS pins during boundary scan. This pin should be pulled high on the board for functional operation.

Supervisory Features

- Parallel bus integrity:
 - Parity error checking is implemented on each of the four parallel input buses. Even and odd parity is supported as controlled from the CPU interface (per device control). Upon detection of an error, an interrupt is raised. This feature is on a per-channel basis.
- Note:** On parallel output ports, parity is calculated over the 8-bit data bus and not on the SPE and C1J1 lines.
- TOH serial port integrity:
 - There is even parity generation on each of the four TOH serial output ports. There is even parity error checking on each of the four TOH serial input ports. There is one parity bit imbedded in the TOH frame. It occupies the most significant bit location of A1 byte of STS-1. Upon detection of an error, an interrupt is raised. This feature is on a per-channel basis.
- LVDS link integrity:
 - There is B1 parity generation on each of the four LVDS output channels. There is also performance monitoring on each of the four LVDS input channels, implemented as B1 parity error checking. Upon detection of an error, a counter is incremented (one count per errored bit) and an interrupt is raised. The counter is 7 bits wide plus one overflow indicator bit. This feature is on a per-channel basis.
- Framer monitor:
 - The framer in the receive direction will report loss of frame (LOF) as an interrupt, as well as a LOF count and errored frame count. The LOF interrupt must not be clearable as long as the channel is in the LOF state. In addition, the errored frame count must represent errored frames, and should not increment more than once per frame even if there are multiple errors.
- Receiver internal path integrity:
 - There is even parity generation in the receiver section (after descrambler). There is also even parity error checking in the receiver section (before output). Upon detection of an error, an interrupt is raised. This feature is on a per-channel basis.
- Pointer mover performance monitoring:
 - There is pointer mover performance monitoring in the receiver section. Alarm indication signal path (AIS-P) and concatenation is reported, as well as elastic store overflows.
- AIS-P is implemented as a per STS-1 interrupt. In case of concatenated payload, only the interrupt associated with the head of the group will be active.
- Concatenation is reported as a per STS-1 status, and is high when STS-1 is concatenated; and low when not concatenated.
- Elastic store overflow will generate an interrupt on a per STS-1 basis.
- FIFO aligner monitoring:
 - There is monitoring of the FIFO aligner operating point, and upon deviating from the nominal operating point of the FIFO by more than user-programmable threshold values (min and max threshold values), an interrupt is raised. Threshold values are defined per device, flags are per channel.
- Frame offset monitoring:
 - There is monitoring of the frame offset between all enabled channels (disabled channels must not interfere with the monitoring). Monitoring is performed continuously. Upon exceeding the maximum allowed frame offset (18 bytes) between all enabled channels, an interrupt is raised.
- CPU interface monitoring:
 - There is monitoring of potential write cycles that may occur when operating in write protect mode. Upon detecting a write access to the application specific integrated circuit (ASIC) when the device is in write protect mode, an interrupt is raised (W-LOCK flag).

Test Features

- Line loopback:
 - There is a line loopback feature allowing the user to perform a loopback on the line side (per device control). The line frame signal used by the pointer mover is automatically replaced by the system frame signal when operating in line loopback mode.
- LVDS loopback:
 - There is a LVDS loopback feature allowing the user to perform a loopback on the LVDS side (per device control).
- A1/A2 error insert:
 - There is a frame error inject feature, in the transmitter section, allowing the user to replace framing bytes A1/A2 (only last A1 byte and first A2 byte) with a selectable A1/A2 byte value for a selectable number of consecutive frames. The number of consecutive frames to alter is specified by a 4-bit field, while A1/A2 value is specified by two 8-bit fields. The error insert feature is on a per-channel basis, A1/A2 values and 4-bit frame count value are on a per-device basis.
- B1 error insert:
 - There is a B1 error insert feature, in the transmitter section, allowing the user to insert errors on user selectable bits in the B1 byte. Errors are created by simply inverting bit values. Bits to invert will be specified through an 8-bit register (each bit is associated with one of the eight B1 bits). To insert an error, software will first set the bits in the transmitter B1 error insert mask. Then, on a per-channel basis, software will write a one to the b1 error insert command. The insertion circuitry performs a rising edge detect on the bit, and will issue a corruption signal for the next frame, for one frame only. This feature is on a per-channel basis.
- TOH serial output port parity error insert:
 - There is a parity error inject feature, in the receive section, allowing the user to invert the parity bit of each serial output port. This feature inserts a single error. This feature is on a per-channel basis.
- Parallel output bus parity error insert:
 - There is a parity error inject feature, in the receive section, allowing the user to invert parity lines associated with each output parallel buses. This feature inserts a single error. This feature is on a per-channel basis. This feature supports both even and odd parities.
- Scrambler/descrambler disable:
 - There is a scrambler/descrambler disable feature, allowing the user to disable the scrambler of the transmitter and the descrambler of the receiver. The B1 is calculated (in transmitter and receiver) on the nonscrambled data stream. This feature is per device.

Transmit Direction (Line to Backplane)

Each TOH insert block receives two byte-wide 77.76 MHz data from the line, which nominally represents two STS-12 streams (A and B). Transport overhead bytes are then optionally inserted into these streams and the streams are forwarded to the HSI. All byte timing pulses required to isolate individual overhead bytes (e.g., A1, A2, B1, D1—D12, etc.) are generated internally based on a Frame_Sync received from the system (SYS_FP).

- A1 and A2 insertion and optional corruption.
- H1, H2, and H3 pass through transparently.
- B1 calculation (after scrambling), insertion and optional corruption (before scrambling).
- Optional K1 and K2 insert.
- Optional S1/M0 insert.
- Optional E1/F1/E2 insert.
- Optional section and line data communication channel (DCC, D1—D12) insertion (for intercard communications channel).
- Scrambling of outgoing data stream with optional scrambler disabling.
- Optional stream disabling.

All streams operate byte wide at 77.76 MHz (622 Mbits/s) in all modes.

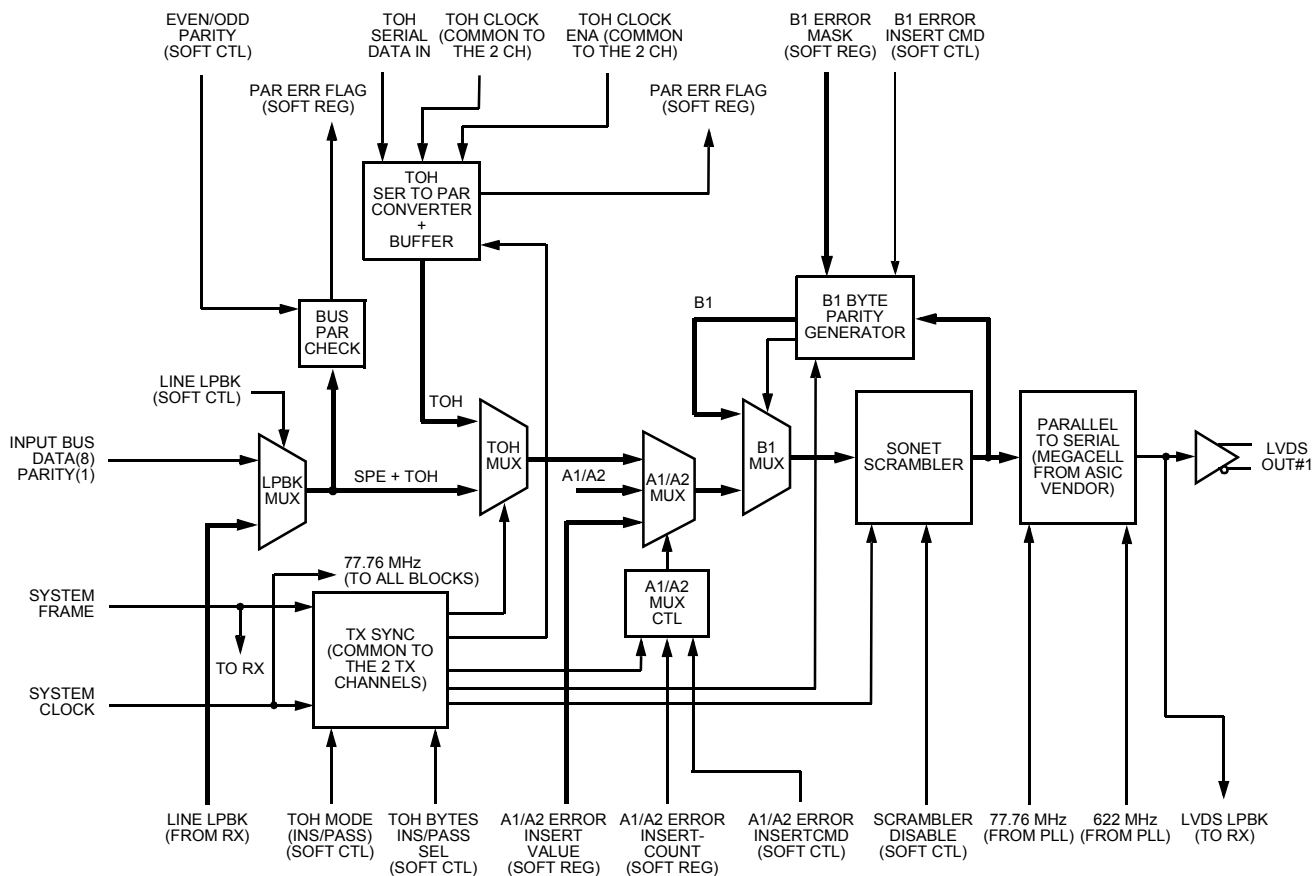

Figure 7. Transmitter Block

Transmit Direction (Line to Backplane) (continued)

Transport Overhead Serial Link

The TOH serial links are used to insert TOH bytes into the transmit data. TOH_IN and TOH_CLK_EN get retimed by TOH_CLK in order to meet setup and hold specifications of the device.

Insertion or passthrough of the TOH is under software control.

TOH parity is calculated using the initial retimed data (TOH_IN_D).

A1/A2 Frame Insert and Corruption

When not corrupted, for each stream, all twelve A1 bytes of the STS-12 are set to 0xF6 and all twelve A2 bytes of the STS-12 are set to 0x28.

Corruption is controlled per stream by the A1/A2 error insert register. When A1/A2 corruption is set for a particular stream, the A1/A2 value in the corrupted A1/A2 value registers are sent for the number of frames defined in the corrupted A1/A2 frame count register (see Table 6 on page 33 and Table 7 on page 36 for register details).

Note: When the corrupted A1/A2 frame count register is set to zero, A1/A2 corruption will continue until the A1/A2 error insert register is cleared, i.e., indefinitely.

On a per-device basis, the A1 and A2 byte values are set, as well as the number of frames of corruption. Then, to insert the specified A1/A2 values, each channel has an enable register. When the enable register is set, the A1/A2 values are corrupted for the number specified in the number of frames to corrupt. To insert errors again, the per-channel fault insert register must be cleared, and set again.

Only the last A1 and the first A2 are corrupted.

B1 Calculation and Insertion

The B1 calculation block computes a BIP-8 code, using even parity over all bits of the previous STS-n frame after scrambling and is inserted in the B1 byte of the current STS-n frame before scrambling. Per-bit B1 corruption is controlled by the force BIP-8 corruption register (per device register). For any bit set in this register, the corresponding bit in the calculated BIP-8 is inverted before insertion into the B1 byte position. Each stream has an independent fault insert register that enables the inversion of the B1 bytes. B1 bytes in all other STS-1s in the stream are passed through transparently.

Stream Disable

When disabled via the appropriate bit in the stream enable register, the prescrambled data for a stream is set to all ones, feeding the HSI. The HSI macro is powered down on a per-stream basis, as is the LVDS outputs.

Scrambler

The data stream is scrambled using a frame synchronous scrambler of sequence length 127, operating at the line rate. The scrambling function can be disabled by software.

The generating polynomial for the scrambler is $1 + x^6 + x^7$.

The scrambler is reset to 111_1111 on the first byte of the SPE (byte following the Z0 byte in the twelfth STS-1). That byte and all subsequent bytes to be scrambled are exclusive ORed, with the output from the byte-wise scrambler. The scrambler runs continuously from that byte on throughout the remainder of the frame.

A1, A2, J0, and Z0 bytes are not scrambled.

Receiver Block

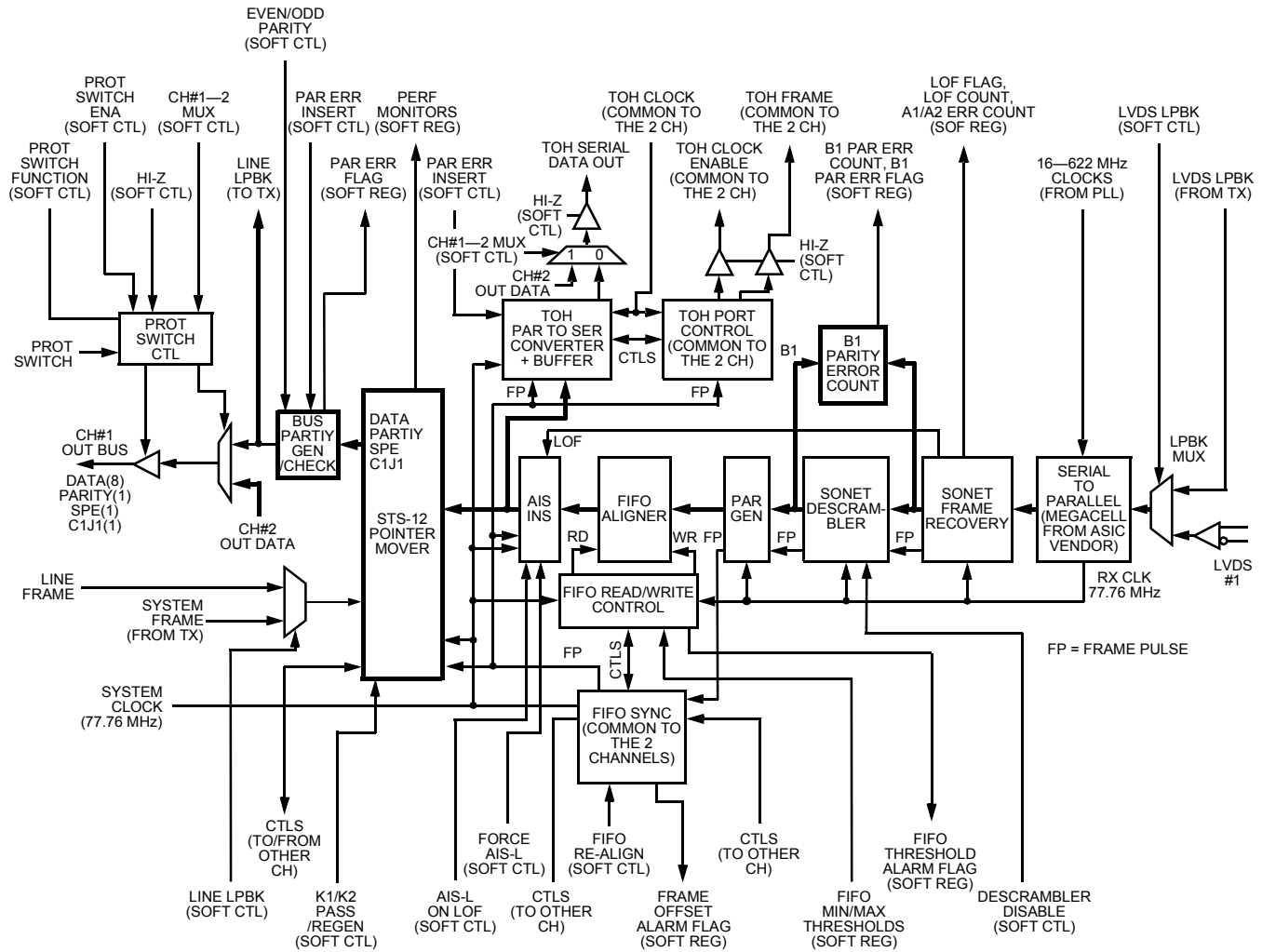

Figure 8. Receiver Block

Framer Subblock (Backplane to Line)

The framer block takes byte-wide data from the HSI, and outputs a byte-aligned byte-wide stream and 8 kHz sync pulse (asserted one clock before the first A1 byte). The framer algorithm determines the out-of-frame/in-frame status of the incoming data and will cause interrupts on both an errored frame and an OOF state.

Features

- A1—A2 framing pattern detection.
- Framing similar to SONET specification.
- Generates timing and an 8 kHz frame pulse.
- Detects OOF and generates an interrupt.
- Detects errored frame and increments counter.

Receiver Block (continued)

Framer Subblock (Backplane to Line) (continued)

Framer State Machine

Figure 9 shows the state machine that controls the framer. Since the TTSV02622 is intended for use between ASICs via a backplane, there is only one errored frame state; thus, after two transitions are missed, the state machine goes into the OOF state and there is no SEF or LOF indication.

OOF State. In this state, the A1 pattern is searched for on every clock cycle.

A second stage of comparison is implemented to locate the A1/A2 transition. When the A1/A2 transition is found, the following occurs:

- The state machine moves from the OOF state to the frame confirm state.
- The A1offset for the byte start location is locked.
- The row, column, and STS counters are set.

Frame Confirm. In this state, the A1/A2 transition is only compared for at the appropriate location, i.e., beginning at the twelfth A1 location. This location is determined from the row, column, and STS counters which were set at the transition from OOF to frame confirm. If at this time the comparison fails, the state machine reverts to the OOF state. If the comparison passes, the next state will be In frame.

In Frame. This state is similar to the frame confirm state except that if the comparison at the A1/A2 time is incorrect, the next state will be the errored frame state. If the comparison is correct, the next state will be in frame.

Errored Frame. Once the errored frame state has been reached, if the next comparison is incorrect, the next state will be OOF. Otherwise, if correct, the next state will be in frame. This state will generate an error interrupt to the micro.

Receiver Block (continued)

Framer Subblock (Backplane to Line) (continued)

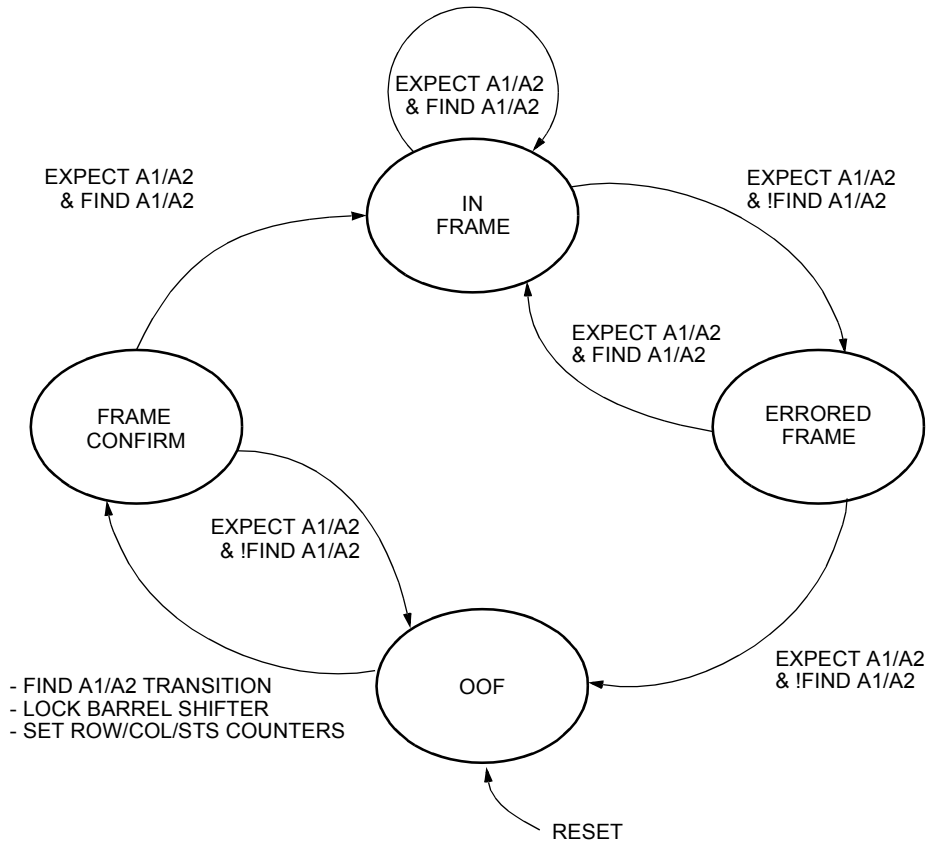

Notes:
 Row, column, and STS counters are only set/reset by state transition from OOF to frame confirm.
 Expect A1/A2 means that row/col/STS counter values indicate time for last (twelfth) A1 byte.

Figure 9. Framer State Machine

Receiver Block (continued)

B1 Calculate and Descramble (Backplane to Line)

Each Rx block receives byte-wide scrambled 77.76 MHz data and a frame sync from the framer. Since each HSI is independently clocked, the Rx block operates on individual streams. Timing signals required to locate overhead bytes to be extracted are generated internally based on the frame sync. The frame sync occurs one clock pulse before the first A1 byte of the stream. The Rx block produces byte-wide descrambled data and an output frame sync for the alignment FIFO block. The output frame sync occurs two clocks before the first A1 byte of the descrambled data stream to allow for metastable hardening by the write control subblock.

On the received data, the following functionality is needed:

- Descrambling of received data stream with optional descrambling disable.
- B1 verification.

Descrambling

The streams are scrambled using a frame synchronous scrambler of sequence length 127, operating at the line rate. The descrambling function can be disabled by software.

The generating polynomial for the scramble is $1 + x^6 + x^7$.

The scrambler is reset to 1111111 on the first byte of the SPE (byte following the Z0 byte in the twelfth STS-1). That byte and all subsequent bytes to be scrambled are exclusive ORed, with the output from the byte-wise scrambler. The scrambler runs continuously from that byte on throughout the remainder of the frame.

A1, A2, J0, and Z0 bytes are not scrambled.

B1 Verification

The B1 calculation block computes a BIP-8 code, using even parity over all bits of the previous STS-12 frame before descrambling, and this value is checked against the B1 byte of the current frame after descrambling. A per-stream B1 error counter is incremented for each bit that is in error.

Alarm Indication Signal Line (AIS-L) Insertion

If enabled via AIS_L_INSERT[x] bit in the AIS_L force register, AIS-L is inserted into the received frame by writing all ones for all bytes of the descrambled stream.

AIS-L Insertion on Out of Frame

If enabled via the appropriate bit in the AIS_L force on out of frame register, AIS-L is inserted into the received frame by writing all ones for all bytes of the descrambled stream when the framer indicates that an out of frame condition exists.

Internal Parity Generation

An even parity is generated on all data bytes and is routed in parallel with the data to be checked before the protection switch MUX at the parallel output.

Receiver Block (continued)

FIFO Subblock (Backplane to Line)

The FIFO subblock consists of a 24 by 10-bit FIFO per STS-12. This FIFO will be used to align up to ± 154.3 ns of interlink skew and to transfer to the system clock.

FIFO Sync Subblock (Backplane to Line)

This FIFO sync block takes metastable hardened frame pulses from the write control blocks and produces sync signals that indicate when the read control blocks should begin reading from the first FIFO location. On top of the sync signals, this block produces an error indicator which indicates that the signals to be aligned are too far apart for alignment (i.e., greater than 18 clocks apart). Sync and error signals are sent to read control block for alignment.

The read control block is synchronized only once on start-up, and any further synchronizing is software (S/W) controlled. The action of resynchronizing a read control block will always cause a data hit. A software register allows the read control block to be resynchronized.

Recommended Procedure for Synchronization of Selected Streams

- Force AIS-L in all streams to be synchronized.
- Wait four frames.
- Write a 1 to the FIFO alignment resynchronizing register, bit DB1 of register 0x06.
- Wait four frames.
- Release the AIS-L in all streams.

Pointer Mover Subblock (Backplane to Line)

The pointer mover simply maps incoming frames to the line framing. The K1/K2 bytes and H1—SS bits are also passed through to the pointer generator so that the line can receive them. The mover will handle both concatenations inside the STS-12, and to other STS-12s inside the TTSV02622.

Pointer Interpreter State Machine

The pointer interpreter is minimized as much as possible to keep the gate count low. In keeping with that goal, the pointer interpreter has only three states (NORM, AIS, and CONC). The interpreter's highest priority is to maintain accurate dataflow (i.e., valid SPE only). This will ensure that any errors in the pointer value will be corrected by a standard pointer interpreter without any data hits. This means that error checking for increment, decrement, and NDF (i.e., 8 of 10) are maintained in order to ensure accurate dataflow. A single valid pointer (i.e., 0—782) that differs from the current pointer will be ignored. Two consecutive incoming valid pointers that differ from the current pointer will cause a reset of the J1 location to the latest pointer value (the generator will then produce an NDF). This block is designed to handle single bit errors without affecting dataflow or changing state, but it is not compliant with SONET standards.

Receiver Block (continued)

Pointer Mover Subblock (Backplane to Line) (continued)

Rules for Concatenation. The pointer mover block can correctly process any length of concatenation (multiple of three) as long as it begins on an STS-3 boundary (i.e., STS-1 number 1, 4, 7, 10, etc.) and is contained within the smaller of STS-3, 12 or 24 (see Table 4).

Table 4. Valid Starting Positions for a STS-MC

STS-1 Number	STS-3c SPE	STS-6c SPE	STS-9c SPE	STS-12c SPE	STS-15c SPE	STS-18c to STS-24c SPEs
1	Y	Y	Y	Y	Y	Y
4	Y	Y	Y	NO	Y	—
7	Y	Y	NO	NO	Y	—
10	Y	NO	NO	NO	Y	—
13	Y	Y	Y	Y	Y	—
16	Y	Y	Y	NO	Y	—
19	Y	Y	NO	NO	Y	—
22	Y	NO	NO	NO	Y	—

Notes:

Y = STS-Mc SPE can start in that STS-1.

NO = STS-Mc SPE cannot start in that STS-1.

— = Y or NO, depending on the particular value of M.

Rules for Pointer Interpretation.

- $NDF \leq N$ bits in H1 byte = (1001 + single bit error).
- $NRMNBTS$ (i.e., NDF not set) $\leq N$ bits in H1 byte = (0110 + single bit error).
- $CONC$ pointer $\leq (N$ bits in H1 byte = 1001 + single bit error) and offset = 11_1111_1111.
- AIS pointer \leq offset and N bits are all 1s (SS bits are ignored).
- $NORM$ pointer \leq (offset 0—782) and (NDF or $NRMNBITS$).

Receiver Block (continued)**Pointer Mover Subblock (Backplane to Line)** (continued)

NORM State. This state will begin whenever two consecutive NORM pointers are received. If two consecutive NORM pointers are received, such that both differ from the current offset, then the current offset will be reset to the last received NORM pointer. When the pointer interpreter changes its offset, it causes the pointer generator to receive a J1 value in a new position. When the pointer generator gets an unexpected J1, it resets its offset value to the new location and declares an NDF.

Note: The interpreter is only looking for two consecutive pointers that are different from the current value. These two consecutive NORM pointers **do not have to have the same value.**

For example; if the current pointer is 10 and you receive a NORM pointer with offset of 15 and a second NORM pointer with offset of 25, then the interpreter will change the current pointer to be 25.

CONC State. The receipt of two consecutive CONC pointers causes this state to be entered. Once in this state, offset values from the head of the concatenation chain are used to determine the location of the STS SPE for each STS in the chain.

AIS State. Two consecutive AIS pointers cause this state to occur. Any two consecutive normal or concatenation pointers will end this state. This state will cause the data leaving the pointer generator to be overwritten with 0xFF.

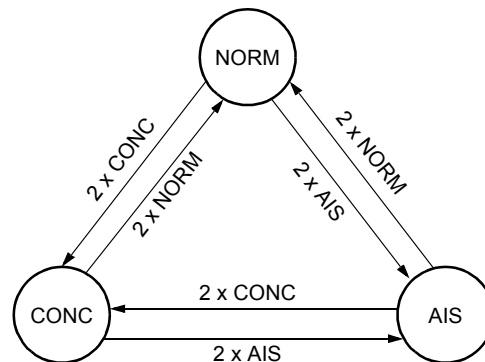

Figure 10. Pointer Mover State Machine

Pointer Generator

The pointer generator simply maps the corresponding bytes into their appropriate location in the outgoing byte stream. The generator also creates offset pointers based on the location of the J1 byte as indicated by the pointer interpreter. The generator will signal NDFs when the interpreter signals that it is coming out of AIS state. The generator resets the pointer value and generates NDF every time a byte marked J1 is read from the elastic store that doesn't match the previous offset.

Increments and decrements signals from the pointer interpreter are latched once per frame on either the F1 or E2 byte times (depending on collisions), this ensures constant values during the H1 through H3 times. The choice of which byte time to do the latching on is made when the relative frame phases (i.e., received and system) is determined. This latch point will then be stable, unless the relative framing changes and the received H byte times collide with the system F1 or E2 times, in which case the latch point would be switched to the collision-free byte time.

Receiver Block (continued)

Pointer Mover Subblock (Backplane to Line) (continued)

There is no restriction on how many or how often increments and decrements are processed. Any received increment or decrement is immediately passed to the generator for implementation regardless of when the last pointer adjustment was made. The responsibility for meeting the SONET criteria for max frequency of pointer adjustments is then left to the upstream pointer processor.

When the interpreter signals an AIS state, the generator will immediately begin sending out 0xFF in place of data and H1, H2, H3. This will continue until the interpreter returns to NORM or CONC states and a J1 byte is received.

Miscellaneous Functions

K1/K2, A1/A2 Handling

K1/K2 bytes can be optionally passed through the pointer mover under software control, or it can be set to zero with the other TOH bytes. A1/A2 bytes are regenerated and set to F6 and 28, respectively.

SPE C1J1 Outputs

In an attempt to minimize the complexity required from the pointer processor that may be hooked-up to the TTSV02622 parallel output port, two signals (per channel) must be provided to the external world; these are called SPE and C1J1. These two signals will allow a pointer processor to extract payload without interpreting the pointers.

Table 5. SPE and C1J1 Functionality

SPE	C1J1	Description
0	0	TOH information excluding C1(J0) of STS-1 #1.
0	1	Position of C1(J0) of STS-1 #1.
1	0	SPE information excluding the 12 J1 bytes.
1	1	Position of the twelve J1 bytes.

The following rules must be observed for generating SPE and C1J1 signals:

- On occurrence of AIS-P on any of the STS-1, there must be no corresponding J1 pulse.
- In case of concatenated payloads (up to STS-24c), only the head STS-1 of the group must have an associated J1 pulse.
- C1J1 signal must track any pointer movements.
- During a negative justification event, SPE must be set high during the H3 byte to indicate that payload data is available.
- During a positive justification event, SPE must be set low during the positive stuff opportunity byte to indicate that payload data is not available.

Registers

Definition of Register Types

The TTSV02622 design contains six structural register elements: SREG, CREG, PREG, IAREG, ISREG, and IEREG. There are no mixed registers in TTSV02622. This means that all bits of a particular register (particular address) are structurally the same and are as follows:

- Status register (SREG):
 - A status register is read only, and as the name implies is used to convey the status information of a particular element or function of the TTSV02622 chip. The reset value of an SREG is really the reset value of the particular element or function that is being read. In some cases, an SREG is really a fixed value; an example of which is the fixed id and revision registers.
- Control register (CREG):
 - A control register is read and writable memory element inside CORE_CONTROL. The value of a CREG will always be the value written to it. Events inside the TTSV02622 chip cannot affect a CREG value. The only exception is a soft reset, in which case the CREG will return to its reset value. The control register have reset values as defined in the reset value column of Table 6 on page 33.
- Pulse register (PREG):
 - Each element, or bit, of a pulse register is a control or event signal that is asserted and then deasserted when a value of 1 is written to it. This means that each bit is always of value 0 until it is written to, upon which it is pulsed to the value of 1 and then returned to a value of 0. A pulse register will always have a read value of 0.
- Interrupt alarm register (IAREG):
 - Each bit of an interrupt alarm register is a event latch. When a particular event is produced in the TTSV02622 chip, its occurrence is latched by its associated IAREG bit. To clear a particular IAREG bit, a value of 1 must be written to it. In the TTSV02622 chip, all IAREG reset values are 0.
- Interrupt status register (ISREG):
 - Each bit of an interrupt status register is physically the logical OR function. It is a consolidation of lower-level interrupt alarms and/or ISREG bits from **other** registers. A direct result of the fact that each bit of the ISREG is a logical OR function means that it will have a read value of 1 if any of the consolidation signals are of value 1, and will be of value 0 if and only if all consolidation signals are of value 0. In the TTSV02622 chip, all ISREG reset values are 0.
- Interrupt enable register (IEREG):
 - Each bit of a status register or alarm register has an associated enable bit. If this bit is set to value 1, then the event is allowed to propagate to the next higher level of consolidation. If this bit is set to zero, then the associated IAREG or ISREG bit can still be asserted but an alarm will not propagate to the next higher level. Obviously, an interrupt enable bit is an interrupt mask bit when it is set to value 0.

Registers (continued)

Register Map

Table 6. Register Map

ADDR* [6:0]	Reg. Type	DB7	DB6	DB5	DB4	DB3	DB2	DB1	DB0	Reset Value (hex)	Comments
00	SREG	FIXED ID MSB								A0	Generic register block.
01	SREG	FIXED ID LSB								01	
02	SREG	FIXED REV								01	
03	CREG	SCRATCH PAD								00	
04	CREG	LOCKREG MSB								00	
05	CREG	LOCKREG LSB								00	
06	PREG	—†	—†	—†	—†	—†	—†	FIFO ALIGNMENT COMMAND	GLOBAL RESET COMMAND	NA	
Device Register Block											
08	CREG	—†	—†	—†	Rx TOH FRAME AND Rx TOH CLOCK ENABLE HI-Z CONTROL	EXT PROT SW EN	EXT PROT SW FUNC	STS-12 SELECT	LVDS LPBK CONTROL	00	Device register block (Rx).
09	CREG	—†	—†	—†	—†	—†	PARALLEL PORT OUTPUT MUX SELECT FOR CH1	—†	SERIAL PORT OUTPUT MUX SELECT FOR CH1	0F	
0A	CREG	—†	—†	—†	FIFO ALIGNER THRESHOLD VALUE (min)					02	
0B	CREG	—†	—†	—†	FIFO ALIGNER THRESHOLD VALUE (max)					15	
0C	CREG	—†	SCRAMBLER/DESCRAMBLER CONTROL	I/O PARALLEL BUS PARITY CONTROL	LINE LPBK CONTROL	NUMBER OF CONSECUTIVE A1/A2 ERRORS TO GENERATE [3:0]				60	Device register block (Tx).
0D	CREG	A1 ERROR INSERT VALUE								00	
0E	CREG	A2 ERROR INSERT VALUE								00	
0F	CREG	TRANSMITTER B1 ERROR INSERT MASK								00	
10	ISREG	—†	—†	—†	PER DEVICE INT	—†	—†	CH 2 INT	CH 1 INT	00	
11	IEREG	—†	—†	—†	ENABLE/MASK REGISTER [4:0]					00	Top-level interrupts.
12	IAREG	—†	—†	—†	—†	—†	—†	WRITE TO LOCKED REGISTER ERROR FLAG	FRAME OFFSET ERROR FLAG	00	
13	IEREG	—†	—†	—†	—†	—†	—†	ENABLE/MASK REGISTER		00	

* ADDR values delimited by a comma indicate the address for each of two channels, from channel 1 or 2. For example, the register for Tx control signals has addresses of 20 and 38. This indicates that channel 1 Tx control signals are at address 20 and channel 2 Tx control signals are at address 38.

† Reserved.

Registers (continued)

Register Map (continued)

Table 6. Register Map (continued)

ADDR* [6:0]	Reg. Type	DB7	DB6	DB5	DB4	DB3	DB2	DB1	DB0	Reset Value (Hex)	Comments
Channel Register Block											
20, 38	CREG	HI-Z CONTROL OF TOH DATA OUTPUT	HI-Z CONTROL OF PARALLEL OUTPUT BUS	CHANNEL ENABLE / DISABLE CONTROL	PARALLEL OUTPUT BUS PARITY ERR INS CMD	Rx K1/K2 SOURCE SELECT	TOH SERIAL OUTPUT PORT PAR ERR INS CMD	FORCE AIS-L CONTROL	Rx BEHAVIOR IN LOF	01	Rx control signals.
21, 39	CREG	Tx MODE OF OPERATION	Tx E1/F1/E2 SOURCE SELECT	Tx S1/M0 SOURCE SELECT	Tx K1/K2 SOURCE SELECT	Tx D12 SOURCE SELECT	Tx D11 SOURCE SELECT	Tx D10 SOURCE SELECT	Tx D9 SOURCE SELECT	00	Tx control signals.
22, 3A	CREG	Tx D8 SOURCE SELECT	Tx D7 SOURCE SELECT	Tx D6 SOURCE SELECT	Tx D5 SOURCE SELECT	Tx D4 SOURCE SELECT	Tx D3 SOURCE SELECT	Tx D2 SOURCE SELECT	Tx D1 SOURCE SELECT	00	
23, 3B	CREG	—†	—†	—†	—†	—†	—†	B1 ERROR INSERT COMMAND	A1/A2 ERROR INSERT COMMAND	00	
24, 3C	SREG	—†	—†	—†	—†	CONCAT INDICATION 12	CONCAT INDICATION 9	CONCAT INDICATION 6	CONCAT INDICATION 3	NA	
25, 3D	SREG	CONCAT INDICATION 11	CONCAT INDICATION 8	CONCAT INDICATION 5	CONCAT INDICATION 2	CONCAT INDICATION 10	CONCAT INDICATION 7	CONCAT INDICATION 4	CONCAT INDICATION 1	NA	
26, 3E	ISREG	—†	—†	—†	—†	—†	ELASTIC STORE OVERFLOW FLAG	AIS-P FLAG	PER STS-12 ALARM FLAG	00	Per-channel interrupt consolidation.
27, 3F	IEREG	—†	—†	—†	—†	—†	ENABLE/MASK REGISTER [2:0]		00		
28, 40	IAREG	—†	—†	TOH SERIAL INPUT PORT PARITY ERROR FLAG	INPUT PARALLEL BUS PARITY ERROR FLAG	LVDS LINK B1 PARITY ERROR FLAG	LOF FLAG	RECEIVER INTERNAL PATH PARITY ERROR FLAG	FIFO ALIGNER THRESHOLD ERROR FLAG	00	Per STS-12 interrupt flags.
29, 41	IEREG	—†	—†	ENABLE/MASK REGISTER [5:0]						00	

* ADDR values delimited by a comma indicate the address for each of two channels, from channel 1 or 2. For example, the register for Tx control signals has addresses of 20 and 38. This indicates that channel 1 Tx control signals are at address 20 and channel 2 Tx control signals are at address 38.

† Reserved.

Registers (continued)

Register Map (continued)

Table 6. Register Map (continued)

ADDR* [6:0]	Reg. Type	DB7	DB6	DB5	DB4	DB3	DB2	DB1	DB0	Reset Value (hex)	Comments
Channel Register Block (continued)											
2A, 42	IAREG	—†	—†	—†	—†	AIS INTERRUPT FLAGS 12	AIS INTERRUPT FLAG 9	AIS INTERRUPT FLAGS 6	AIS INTERRUPT FLAGS 3	00	Per STS-1 interrupt flags.
2B, 43	IAREG	AIS INTERRUPT FLAG 11	AIS INTERRUPT FLAG 8	AIS INTERRUPT FLAG 5	AIS INTERRUPT FLAG 2	AIS INTERRUPT FLAG 10	AIS INTERRUPT FLAG 7	AIS INTERRUPT FLAG 4	AIS INTERRUPT FLAG 1	00	
2C, 44	IAREG	—†	—†	—†	—†	ENABLE/MASK AIS INTERRUPT FLAGS 12	ENABLE/MASK AIS INTERRUPT FLAG 9	ENABLE/MASK AIS INTERRUPT FLAGS 6	ENABLE/MASK AIS INTERRUPT FLAGS 3	00	
2D, 45	IAREG	ENABLE/MASK AIS INTERRUPT FLAG 11	ENABLE/MASK AIS INTERRUPT FLAG 8	ENABLE/MASK AIS INTERRUPT FLAG 5	ENABLE/MASK AIS INTERRUPT FLAG 2	ENABLE/MASK AIS INTERRUPT FLAG 10	ENABLE/MASK AIS INTERRUPT FLAG 7	ENABLE/MASK AIS INTERRUPT FLAG 4	ENABLE/MASK AIS INTERRUPT FLAG 1	00	
2E, 46	IAREG	—†	—†	—†	—†	ES OVERFLOW FLAGS 12	ES OVERFLOW FLAG 9	ES OVERFLOW FLAGS 6	ES OVERFLOW FLAGS 3	00	
2F, 47	IAREG	ES OVERFLOW FLAG 11	ES OVERFLOW FLAG 8	ES OVERFLOW FLAG 5	ES OVERFLOW FLAG 2	ES OVERFLOW FLAG 10	ES OVERFLOW FLAG 7	ES OVERFLOW FLAG 4	ES OVERFLOW FLAG 1	00	
30, 48	IAREG	—†	—†	—†	—†	ENABLE/MASK ES OVERFLOW FLAGS 12	ENABLE/MASK ES OVERFLOW FLAG 9	ENABLE/MASK ES OVERFLOW FLAGS 6	ENABLE/MASK ES OVERFLOW FLAGS 3	00	
31, 49	IAREG	ENABLE/MASK ES OVERFLOW FLAG 11	ENABLE/MASK ES OVERFLOW FLAG 8	ENABLE/MASK ES OVERFLOW FLAG 5	ENABLE/MASK ES OVERFLOW FLAG 2	ENABLE/MASK ES OVERFLOW FLAG 10	ENABLE/MASK ES OVERFLOW FLAG 7	ENABLE/MASK ES OVERFLOW FLAG 4	ENABLE/MASK ES OVERFLOW FLAG 1	00	
32, 4A	COUNTER	OVERFLOW	LVDS LINK B1 PARITY ERROR COUNTER							00	Binning.
33, 4B	COUNTER	OVERFLOW	LOF COUNTER							00	
34, 4C	COUNTER	OVERFLOW	A1/A2 FRAME ERROR COUNTER							00	

* ADDR values delimited by a comma indicate the address for each of two channels, from channel 1 or 2. For example, the register for Tx control signals has addresses of 20 and 38. This indicates that channel 1 Tx control signals are at address 20 and channel 2 Tx control signals are at address 38.

† Reserved.

Register Descriptions

Table 7. Register Description

Address (hex)	Bit	Name	Type	Description	Reset Value (hex)
00	[7:0]	FIXED ID MSB	SREG	NA.	A0
01	[7:0]	FIXED ID LSB	SREG	NA.	01
02	[7:0]	FIXED REV	SREG	NA.	01
03	[7:0]	SCRATCH PAD	CREG	The scratch pad has no function and is not used anywhere in the TTSV02622 chip. However, this register can be written to and read from.	00
04	[7:0]	LOCKREG MSB	CREG	In order to write to registers in memory locations 06—7F, LOCKREG MSB and LOCKREG LSB must be respectively set to the values of A0 and 01. If the LOCKREG MSB and LOCKREG LSB values are not set to A0 and 01 respectively, then any values written to the registers in memory locations 06—7F will be ignored. After reset (both hard and soft), the TTSV02622 chip is in a write locked mode. The TTSV02622 chip needs to be unlocked before it can be written to. Also note that the scratch pad register (03) can always be written to since it is unaffected by write lock mode.	00
05	[7:0]	LOCKREG LSB	CREG	See address 0x04 bits [7:0] description.	00
06	0	GLOBAL RESET COMMAND	PREG	The FIFO ALIGNMENT and GLOBAL RESET COMMANDS are both accessed via the pulse register in memory address 06. The FIFO ALIGNMENT command is used to frame align the outputs of the four receive STM stream FIFOs. The GLOBAL RESET COMMAND is a soft (software initiated) reset. Nevertheless, the GLOBAL RESET COMMAND will have the exact reset effect as a hard (RST_N pin) reset.	NA
	1	FIFO ALIGNMENT COMMAND	PREG	See address 0x06 bit 0 description.	
	[7:2]	Reserved.			

Register Descriptions (continued)

Table 7. Register Description (continued)

Address (hex)	Bit	Name	Type	Description		Reset Value (hex)	
Device Register Blocks							
08	0	LVDS LPBK CONTROL	CREG	0 = No loopback. 1 = LVDS loopback, transmit to receive on.		00	
	1	STS-12 SELECT	CREG	This control signal is untracked in the TTSV02622 chip. It is a scratch bit, and its value has no effect on the TTSV02622 chip.		00	
	[3:2]	EXT PROT SW EN (bit 3) EXT PROT SW FUNC (bit 2)	CREG	EXT PORT SW EN	EXT PROT SW FUNC	Switching Control Master	00
				0	—	<ul style="list-style-type: none"> ■ MUX is controlled by software (1 control bit per MUX). ■ Output buffers are controlled by software (1 control bit per channel). 	
				1	0	<ul style="list-style-type: none"> ■ MUX on parallel output bus of CH 1 is controlled by PROT_SWITCH_A/B pin. 0 = CH 1. 1 = CH 2. ■ Output buffers are controlled by software (1 control bit per channel). 	
	4	Rx TOH FRAME AND Rx TOH CLOCK ENABLE HI-Z CONTROL	CREG	0 = High impedance. 1 = Enable receive TOH CLK and FP outputs.		00	
Reserved.							
	[7:5]			Reserved.			

Register Descriptions (continued)

Table 7. Register Description (continued)

Address (hex)	Bit	Name	Type	Description	Reset Value (hex)
Device Register Blocks (continued)					
09	0	SERIAL PORT OUTPUT MUX SELECT FOR CH 1	CREG	0 = TOH output 1 is multiplexed to CH 2. 1 = TOH output 1 is multiplexed to CH 1.	0F
	1	Reserved.			
	2	PARALLEL PORT OUTPUT MUX SELECT FOR CH 1	CREG	0 = Parallel output data bus 1 is multiplexed to CH 2. 1 = Parallel output data bus 1 is multiplexed to CH 1.	0F
	3	Reserved.			
	[7:4]	Reserved.			
0A	[4:0]	FIFO ALIGNER THRESHOLD VALUE (min)	CREG	This is the minimum threshold value for the per-channel receive direction alignment FIFOS. If and when the minimum threshold value is violated by a particular channel, then the interrupt event FIFO ALIGNER THRESHOLD ERROR will be generated for that channel and latched as a FIFO ALIGNER THRESHOLD ERROR FLAG in the respective per STS-12 interrupt alarm register. The allowable range for minimum threshold values is 1 to 23. Note: The minimum FIFO aligner threshold values apply to both channels.	02
	[7:5]	Reserved.			
0B	[4:0]	FIFO ALIGNER THRESHOLD VALUE (max)	CREG	This is the maximum threshold value for the per-channel receive direction alignment FIFOS. If and when the maximum threshold value is violated by a particular channel, then the interrupt event FIFO ALIGNER THRESHOLD ERROR will be generated for that channel and latched as a FIFO ALIGNER THRESHOLD ERROR FLAG in the respective per STS-12 interrupt alarm register. The allowable range for maximum threshold values is 0 to 22. Note: The minimum FIFO aligner threshold values apply to both channels.	15
	[7:5]	Reserved.			

Register Descriptions (continued)

Table 7. Register Description (continued)

Address (hex)	Bit	Name	Type	Description	Reset Value (hex)
Device Register Blocks (continued)					
0C	[3:0]	NUMBER OF CONSECUTIVE A1/A2 ERRORS TO GENERATE [3:0]	CREG	<p>These three (0C, 0D, and 0E) per-device control signals are used in conjunction with the per channel A1/A2 ERROR INSERT COMMAND control bits to force A1/A2 errors in the transmit direction.</p> <p>If a particular channel's A1/A2 ERROR INSERT COMMAND control bit is set to the value 1, then the A1 and A2 error insert values will be inserted into that channels respective A1 and A2 bytes. The number of consecutive frames to be corrupted is determined by the NUMBER OF CONSECUTIVE A1 A2 ERRORS TO GENERATE [3:0] control bits.</p> <p>The error insertion is based on a rising edge detector. As such, the control must be set to value 0 before trying to initiate a second A1 A2 corruption.</p>	60
	4	LINE LPBK CONTROL	CREG	0 = No loopback. 1 = Rx to Tx loopback on line side.	0
	5	INPUT/OUTPUT PARALLEL BUS PARITY CONTROL	CREG	0 = Odd parity. 1 = Even parity.	1
	6	SCRAMBLER/DESCRAMBLER CONTROL	CREG	0 = No Rx direction descramble/Tx direction scramble. 1 = In Rx direction, descramble channel after SONET frame recovery. In Tx direction, scramble data just before parallel-to-serial conversion.	1
	7	Reserved.			
0D	[7:0]	A1 ERROR INSERT VALUE	CREG	See address 0x0C bits [3:0] description.	00
0E	[7:0]	A2 ERROR INSERT VALUE	CREG	See address 0x0C bits [3:0] description.	00
0F	[7:0]	TRANSMIT B1 ERROR INSERT MASK	CREG	0 = No error insertion. 1 = Invert corresponding bit in B1 byte.	00

Register Descriptions (continued)

Table 7. Register Description (continued)

Address (hex)	Bit	Name	Type	Description	Reset Value (hex)
Device Register Blocks (continued)					
10	0	CH 1 INT	ISREG	Consolidation interrupts. 0 = No interrupt. 1 = Interrupt.	00
	1	CH 2 INT	ISREG	Consolidation interrupts. 0 = No interrupt. 1 = Interrupt.	00
	[3:2]	Reserved.			
	4	PER DEVICE INT	ISREG	Consolidation interrupts. 0 = No interrupt. 1 = Interrupt.	00
	[7:5]	Reserved.			
11	[4:0]	ENABLE/MASK REGISTER	IEREG		00
	[7:5]	Reserved.			
12	0	FRAME OFFSET ERROR FLAG	IAREG	If in the receive direction the phase offset between any two channels exceeds 17 bytes, then a frame offset error event will be issued. This condition is continuously monitored. If the TTSV02622 memory map has not been unlocked (by writing a 001 to the lock registers), and any address other than the LOCKREG registers or SCRATCH PAD register is written to, then a WRITE TO LOCKED REGISTER event will be generated.	00
	1	WRITE TO LOCKED REGISTER ERROR FLAG	IAREG	See address 0x12 bit 0 description.	00
	[7:2]	Reserved.			
13	[1:0]	ENABLE/MASK REGISTER	IEREG	See address 0x12 bit 0 description.	00
	[7:2]	Reserved.			

Register Descriptions (continued)

Table 7. Register Description (continued)

Address (hex)	Bit	Name	Type	Description	Reset Value (hex)
Channel Register Blocks					
20, 38	0	Rx BEHAVIOR IN LOF	CREG	0 = When Rx direction OOF occurs, do not insert AIS-L. 1 = When Rx direction OOF occurs, insert AIS-L.	1
	1	FORCE AIS-L CONTROL	CREG	0 = Do not force AIS-L. 1 = Force AIS-L.	0
	2	TOH SERIAL OUTPUT PORT PAR ERR INS CMD	CREG	0 = Do not insert a parity error. 1 = Insert parity error in parity bit of receive TOH serial output for as long as this bit is set.	0
	3	Rx K1/K2 SOURCE SELECT	CREG	0 = Set receive direction K2/K2 bytes to 0. 1 = Pass receive direction K1/K2 though pointer mover.	0
	4	PARALLEL OUTPUT BUS PARITY ERR INS CMD	CREG	0 = Do not insert parity error. 1 = Insert parity error in the parity bit of receive direction parallel output bus for as long as this bit is set.	0
	5	CHANNEL ENABLE/DISABLE CONTROL	CREG	0 = Powerdown channel and 3-state output buses. 1 = Functional mode.	0
	6	HI-Z CONTROL OF PARALLEL OUTPUT BUS	CREG	0 = 3-state output bus. 1 = Functional mode.	0
	7	HI-Z CONTROL OF TOH DATA OUTPUT	CREG	0 = 3-state output lines. 1 = Functional mode.	0
21, 39	0	Tx D9 SOURCE SELECT	CREG	0 = Insert TOH from serial ports. 1 = Pass through that particular TOH byte.	0
	1	Tx D10 SOURCE SELECT	CREG	0 = Insert TOH from serial ports. 1 = Pass through that particular TOH byte.	0
	2	Tx D11 SOURCE SELECT	CREG	0 = Insert TOH from serial ports. 1 = Pass through that particular TOH byte.	0
	3	Tx D12 SOURCE SELECT	CREG	0 = Insert TOH from serial ports. 1 = Pass through that particular TOH byte.	0
	4	Tx K1/K2 SOURCE SELECT	CREG	0 = Insert TOH from serial ports. 1 = Pass through that particular TOH byte.	0
	5	Tx S1/M0 SOURCE SELECT	CREG	0 = Insert TOH from serial ports. 1 = Pass through that particular TOH byte.	0
	6	Tx E1/F2/E2 SOURCE SELECT	CREG	0 = Insert TOH from serial ports. 1 = Pass through that particular TOH byte.	0
	7	Tx MODE OF OPERATION	CREG	0 = Insert TOH from serial ports. 1 = Pass through all TOH.	0

Register Descriptions (continued)

Table 7. Register Description (continued)

Address (hex)	Bit	Name	Type	Description	Reset Value (hex)
Channel Register Blocks (continued)					
22, 3A	0	Tx D1 SOURCE SELECT	CREG	0 = Insert TOH from serial ports. 1 = Pass through that particular TOH byte.	0
	1	Tx D2 SOURCE SELECT	CREG	0 = Insert TOH from serial ports. 1 = Pass through that particular TOH byte.	0
	2	Tx D3 SOURCE SELECT	CREG	0 = Insert TOH from serial ports. 1 = Pass through that particular TOH byte.	0
	3	Tx D4 SOURCE SELECT	CREG	0 = Insert TOH from serial ports. 1 = Pass through that particular TOH byte.	0
	4	Tx D5 SOURCE SELECT	CREG	0 = Insert TOH from serial ports. 1 = Pass through that particular TOH byte.	0
	5	Tx D6 SOURCE SELECT	CREG	0 = Insert TOH from serial ports. 1 = Pass through that particular TOH byte.	0
	6	Tx D7 SOURCE SELECT	CREG	0 = Insert TOH from serial ports. 1 = Pass through that particular TOH byte.	0
	7	Tx D8 SOURCE SELECT	CREG	0 = Insert TOH from serial ports. 1 = Pass through that particular TOH byte.	0
23, 3B	0	A1/A2 ERROR INSERT COMMAND	CREG	0 = Do not insert error. 1 = Insert error for number of frames in register 0x0C. The error insertion is based on a rising edge detector. As such, the control must be set to value 0 before trying to initiate a second A1 A2 corruption.	00
	1	B1 ERROR INSERT COMMAND	CREG	0 = Do not insert error. 1 = Insert error for 1 frame in B1 bits defined by register 0x0F. The error insertion is based on a rising edge detector. As such, the control must be set to value 0 before trying to initiate a second B1 corruption.	00
	[7:2]	Reserved.			
24, 3C	0	CONCAT INDICATION 3	SREG	The value 1 in any bit location indicates that STS# is in CONCAT mode. A 0 indicates that the STS is not in CONCAT mode, or is the head of a concatenation group.	NA
	1	CONCAT INDICATION 6	SREG	The value 1 in any bit location indicates that STS# is in CONCAT mode. A 0 indicates that the STS is not in CONCAT mode, or is the head of a concatenation group.	NA
	2	CONCAT INDICATION 9	SREG	The value 1 in any bit location indicates that STS# is in CONCAT mode. A 0 indicates that the STS is not in CONCAT mode, or is the head of a concatenation group.	NA
	3	CONCAT INDICATION 12	SREG	The value 1 in any bit location indicates that STS# is in CONCAT mode. A 0 indicates that the STS is not in CONCAT mode, or is the head of a concatenation group.	NA
	[7:4]	Reserved.			

Register Descriptions (continued)

Table 7. Register Description (continued)

Address (hex)	Bit	Name	Type	Description	Reset Value (hex)
Channel Register Blocks (continued)					
25, 3D	0	CONCAT INDICATION 1	SREG	The value 1 in any bit location indicates that STS# is in CONCAT mode. A 0 indicates that the STS is not in CONCAT mode, or is the head of a concatenation group.	NA
	1	CONCAT INDICATION 4	SREG	The value 1 in any bit location indicates that STS# is in CONCAT mode. A 0 indicates that the STS is not in CONCAT mode, or is the head of a concatenation group.	NA
	2	CONCAT INDICATION 7	SREG	The value 1 in any bit location indicates that STS# is in CONCAT mode. A 0 indicates that the STS is not in CONCAT mode, or is the head of a concatenation group.	NA
	3	CONCAT INDICATION 10	SREG	The value 1 in any bit location indicates that STS# is in CONCAT mode. A 0 indicates that the STS is not in CONCAT mode, or is the head of a concatenation group.	NA
	4	CONCAT INDICATION 2	SREG	The value 1 in any bit location indicates that STS# is in CONCAT mode. A 0 indicates that the STS is not in CONCAT mode, or is the head of a concatenation group.	NA
	5	CONCAT INDICATION 5	SREG	The value 1 in any bit location indicates that STS# is in CONCAT mode. A 0 indicates that the STS is not in CONCAT mode, or is the head of a concatenation group.	NA
	6	CONCAT INDICATION 8	SREG	The value 1 in any bit location indicates that STS# is in CONCAT mode. A 0 indicates that the STS is not in CONCAT mode, or is the head of a concatenation group.	NA
	7	CONCAT INDICATION 11	SREG	The value 1 in any bit location indicates that STS# is in CONCAT mode. A 0 indicates that the STS is not in CONCAT mode, or is the head of a concatenation group.	NA
26, 3E	0	PER STS-12 ALARM FLAG	ISREG	These flag register bits PER STS-12 ALARM FLAG, AIS-P FLAG, and ELASTIC STORE OVERFLOW FLAG are the per-channel interrupt status (consolidation) register.	00
	1	AIS-P FLAG			00
	2	ELASTIC STORE OVERFLOW FLAG			00
	[7:3]	Reserved.			
27, 3F	[2:0]	ENABLE/MASK REGISTER	IEREG	These enable/mask register bits are the per-channel interrupt status (consolidation) register.	0
	[7:3]	Reserved.			

Register Descriptions (continued)**Table 7. Register Description** (continued)

Address (hex)	Bit	Name	Type	Description	Reset Value (hex)
Channel Register Blocks (continued)					
28, 40	0	FIFO ALIGNER THRESHOLD ERROR FLAG	IAREG	These are the PER STS-12 ALARM FLAGS.	00
	1	RECEIVER INTERNAL PATH PARITY ERROR FLAG	IAREG	These are the PER STS-12 ALARM FLAGS.	00
	2	LOF FLAG	IAREG	These are the PER STS-12 ALARM FLAGS.	00
	3	LVDS LINK B1 PARITY ERROR FLAG	IAREG	These are the PER STS-12 ALARM FLAGS.	00
	4	INPUT PARALLEL BUS PARITY ERROR FLAG	IAREG	These are the PER STS-12 ALARM FLAGS.	00
	5	TOH SERIAL INPUT PORT PARITY ERROR FLAG	IAREG	These are the PER STS-12 ALARM FLAGS.	00
	[7:6]	Reserved.			
29, 41	[5:0]	ENABLE/MASK REGISTER	IAREG	These are the PER STS-12 ALARM FLAGS.	0
	[7:6]	Reserved.			
2A, 42	0	AIS INTERRUPT FLAGS 3	IAREG	These are the AIS-P ALARM FLAGS.	0
	1	AIS INTERRUPT FLAGS 6	IAREG	These are the AIS-P ALARM FLAGS.	0
	2	AIS INTERRUPT FLAGS 9	IAREG	These are the AIS-P ALARM FLAGS.	0
	3	AIS INTERRUPT FLAGS 12	IAREG	These are the AIS-P ALARM FLAGS.	0
	[7:4]	Reserved.			

Register Descriptions (continued)

Table 7. Register Description (continued)

Address (hex)	Bit	Name	Type	Description	Reset Value (hex)
Channel Register Blocks (continued)					
2B, 43	0	AIS INTERRUPT FLAGS 1	IAREG	These are the AIS-P ALARM FLAGS.	0
	1	AIS INTERRUPT FLAGS 4	IAREG	These are the AIS-P ALARM FLAGS.	0
	2	AIS INTERRUPT FLAGS 7	IAREG	These are the AIS-P ALARM FLAGS.	0
	3	AIS INTERRUPT FLAGS 10	IAREG	These are the AIS-P ALARM FLAGS.	0
	4	AIS INTERRUPT FLAGS 2	IAREG	These are the AIS-P ALARM FLAGS.	0
	5	AIS INTERRUPT FLAGS 5	IAREG	These are the AIS-P ALARM FLAGS.	0
	6	AIS INTERRUPT FLAGS 8	IAREG	These are the AIS-P ALARM FLAGS.	0
	7	AIS INTERRUPT FLAGS 11	IAREG	These are the AIS-P ALARM FLAGS.	0
2C, 44	0	ENABLE/MASK AIS INTERRUPT FLAG 3	IEREG	These are the AIS-P ALARM FLAGS.	0
	1	ENABLE/MASK AIS INTERRUPT FLAG 6	IEREG	These are the AIS-P ALARM FLAGS.	0
	2	ENABLE/MASK AIS INTERRUPT FLAG 9	IEREG	These are the AIS-P ALARM FLAGS.	0
	3	ENABLE/MASK AIS INTERRUPT FLAG 12	IEREG	These are the AIS-P ALARM FLAGS.	0
	[7:4]	Reserved.			
2D, 45	0	ENABLE/MASK AIS INTERRUPT FLAG 1	IEREG	These are the AIS-P ALARM FLAGS.	0
	1	ENABLE/MASK AIS INTERRUPT FLAG 4	IEREG	These are the AIS-P ALARM FLAGS.	0
	2	ENABLE/MASK AIS INTERRUPT FLAG 7	IEREG	These are the AIS-P ALARM FLAGS.	0
	3	ENABLE/MASK AIS INTERRUPT FLAG 10	IEREG	These are the AIS-P ALARM FLAGS.	0
	4	ENABLE/MASK AIS INTERRUPT FLAG 2	IEREG	These are the AIS-P ALARM FLAGS.	0
	5	ENABLE/MASK AIS INTERRUPT FLAG 5	IEREG	These are the AIS-P ALARM FLAGS.	0
	6	ENABLE/MASK AIS INTERRUPT FLAG 8	IEREG	These are the AIS-P ALARM FLAGS.	0
	7	ENABLE/MASK AIS INTERRUPT FLAG 11	IEREG	These are the AIS-P ALARM FLAGS.	0

Register Descriptions (continued)**Table 7. Register Description** (continued)

Address (hex)	Bit	Name	Type	Description	Reset Value (hex)
Channel Register Blocks (continued)					
2E, 46	0	ES OVERFLOW FLAGS 3	IAREG	These are the ELASTIC STORE OVERFLOW alarm flags.	0
	1	ES OVERFLOW FLAGS 6	IAREG	These are the ELASTIC STORE OVERFLOW alarm flags.	0
	2	ES OVERFLOW FLAGS 9	IAREG	These are the ELASTIC STORE OVERFLOW alarm flags.	0
	3	ES OVERFLOW FLAGS 12	IAREG	These are the ELASTIC STORE OVERFLOW alarm flags.	0
	[7:4]	Reserved.			
2F, 47	0	ES OVERFLOW FLAGS 1	IAREG	These are the ELASTIC STORE OVERFLOW alarm flags.	0
	1	ES OVERFLOW FLAGS 4	IAREG	These are the ELASTIC STORE OVERFLOW alarm flags.	0
	2	ES OVERFLOW FLAGS 7	IAREG	These are the ELASTIC STORE OVERFLOW alarm flags.	0
	3	ES OVERFLOW FLAGS 10	IAREG	These are the ELASTIC STORE OVERFLOW alarm flags.	0
	4	ES OVERFLOW FLAGS 2	IAREG	These are the ELASTIC STORE OVERFLOW alarm flags.	0
	5	ES OVERFLOW FLAGS 5	IAREG	These are the ELASTIC STORE OVERFLOW alarm flags.	0
	6	ES OVERFLOW FLAGS 8	IAREG	These are the ELASTIC STORE OVERFLOW alarm flags.	0
	7	ES OVERFLOW FLAGS 11	IAREG	These are the ELASTIC STORE OVERFLOW alarm flags.	0
30, 48	0	ENABLE/MASK ES OVERFLOW FLAG 3	IAREG	These are the AIS-P ALARM FLAGS.	0
	1	ENABLE/MASK ES OVERFLOW FLAG 6	IAREG	These are the AIS-P ALARM FLAGS.	0
	2	ENABLE/MASK ES OVERFLOW FLAG 9	IAREG	These are the AIS-P ALARM FLAGS.	0
	3	ENABLE/MASK ES OVERFLOW FLAG 12	IAREG	These are the AIS-P ALARM FLAGS.	0
	[7:4]	Reserved.			

Register Descriptions (continued)

Table 7. Register Description (continued)

Address (hex)	Bit	Name	Type	Description	Reset Value (hex)
Channel Register Blocks (continued)					
31, 49	0	ENABLE/MASK ES OVERFLOW FLAG 1	IEREG	These are the AIS-P ALARM FLAGS.	0
	1	ENABLE/MASK ES OVERFLOW FLAG 4	IEREG	These are the AIS-P ALARM FLAGS.	0
	2	ENABLE/MASK ES OVERFLOW FLAG 7	IEREG	These are the AIS-P ALARM FLAGS.	0
	3	ENABLE/MASK ES OVERFLOW FLAG 10	IEREG	These are the AIS-P ALARM FLAGS.	0
	4	ENABLE/MASK ES OVERFLOW FLAG 2	IEREG	These are the AIS-P ALARM FLAGS.	0
	5	ENABLE/MASK ES OVERFLOW FLAG 5	IEREG	These are the AIS-P ALARM FLAGS.	0
	6	ENABLE/MASK ES OVERFLOW FLAG 8	IEREG	These are the AIS-P ALARM FLAGS.	0
	7	ENABLE/MASK ES OVERFLOW FLAG 11	IEREG	These are the AIS-P ALARM FLAGS.	0
32, 4A	[6:0]	LVDS LINK B1 PARITY ERROR COUNTER	COUNTER	7-bit count + overflow – reset on read.	0
	7	OVERFLOW	COUNTER	—	0
33, 4B	[6:0]	LOF COUNTER	COUNTER	7-bit count + overflow – reset on read.	0
	7	OVERFLOW	COUNTER	—	0
34, 4C	[6:0]	A1/A2 FRAME ERROR COUNTER	COUNTER	7-bit count + overflow – reset on read.	0
	7	OVERFLOW	COUNTER	—	0

Absolute Maximum Ratings

Stresses in excess of the absolute maximum ratings can cause permanent damage to the device. These are absolute stress ratings only. Functional operation of the device is not implied at these or any other conditions in excess of those given in the operational sections of the data sheet. Exposure to absolute maximum ratings for extended periods can adversely affect device reliability.

Table 8. Absolute Maximum Ratings

Parameter	Symbol	Min	Max	Unit
Power Supply Voltage with Respect to Ground	V _{DD}	—	4.2	V
Input Voltages	V _{IN}	V _{SS} – 0.3	5.5	V
Power Dissipation	P _D	—	—	mW
Storage Temperature Range	T _{stg}	—	—	°C

Handling Precautions

Although electrostatic discharge (ESD) protection circuitry has been designed into this device, proper precautions must be taken to avoid exposure to ESD and electrical overstress (EOS) during all handling, assembly, and test operations. Agere employs both a human-body model (HBM) and a charged-device model (CDM) qualification requirement in order to determine ESD-susceptibility limits and protection design evaluation. ESD voltage thresholds are dependent on the circuit parameters used in each of the models, as defined by JEDEC's JESD22-A114 (HBM) and JESD22-C101 (CDM) standards.

Table 9. Handling Precautions

Model	Voltage
Minimum HBM Threshold	2000 V
Minimum CDM on the corner pins only and the LU	1000 V
Minimum CDM on all other pins	500 V

Recommended Operating Conditions

The following tables list the voltages required for proper operation of the TTSV02622 device, along with their tolerances.

Table 10. Recommended Operating Conditions

Parameter	Symbol	Min	Max	Unit
Power Supply Voltage with Respect to Ground	V _{DD}	3.14	3.47	V
Input High Voltage (TTL input)	V _{IH}	2.0	5.5	V
Input Low Voltage (TTL input)	V _{IL}	—	0.8	V
Input Voltages	V _{IN}	V _{SS} – 0.3	5.5	V
Junction Temperature	T _j	–40	125	°C

Thermal Characteristics

The TTSV02622 is a 5.86 mm x 6.49 mm die in the 272-pin PBGA (2-layer BGA). For thermal characteristics, the following values should be used:

- $\Theta_{Jc} = 15.38 \text{ }^\circ\text{C/W}$
- $\Theta_{Jb} = 25.09 \text{ }^\circ\text{C/W}$
- $\Theta_{Ja} = 31.92 \text{ }^\circ\text{C/W}$
- $\Psi_{Jt} = 1.00 \text{ }^\circ\text{C/W}$

Table 11. Thermal Resistance—Junction to Ambient

Air Speed in Linear Feet per Minute (LFPM)	Θ_{Ja} ($^\circ\text{C/W}$)
JEDEC Standard Natural Convection	29.48
200	28.65
500	27.42

Power Consumption (Advance)

Table 12. Power Consumption (Advance)

Parameter	Condition	Max	Unit
2 Channel	At 3.3 V	1.6	W
	At 3.465 V	1.7	W

Electrical Characteristics

Table 13. LVTTTL Electrical Characteristics

Parameter	Symbol	Test Conditions	Min	Max	Unit
Output Voltage:					
Low	V_{OL}	—	—	0.4	V
High	V_{OH}	—	2.4	—	V

Propagation Delay Specifications

1. Delay in 77.78 MHz system clocks from the Tx line input to the LVDS backplane output is seven clocks (see Figure 15, Transmitter Transport Delay on page 56).
2. Propagation delay from a change on the PROT SW pin to a protection switch activity:
 - NORM to HI-Z:
 - Five rising edges of SYS_CLK from assertion of the PROT_SW_A/C pins to the data changing to HI-Z.
 - NORM to MUX switch:
 - Eight rising edges of SYS_CLK from assertion of the PROT_SW_A/C pins to the data changing from stream A to B. (See Figure 17 on page 58.)
3. Propagation delay from A1 STS-1 #1 arriving at LVDS input to RX_TOH_FP is 56 SYS_CLKs, and six TOH_CLKs. This will vary by ± 14 SYS_CLKs, 12 each way for the FIFO alignment, and ± 2 SYS_CLKs due to the variability in the clock recovery of the CDR macro.
4. Delay from CS_N going active (CPU write access to reset the chip) to reset being deactivated and CPU interface being ready to handle another access is nine SYS_CLKs.

LVDS I/O

The LVDS buffers are compatible with *IEEE*[®] 1596.3 and *EIA*[®]/TIA-644. However, not all specs listed in the *IEEE* document pertained to just the buffer itself; rather they are system-level specifications. LVDS buffers in the TTSV02622 are compliant to all parts of the *IEEE* 1596.3 spec that pertain to silicon implementation.

Unused inputs will not oscillate when they are open or short-circuited. Both P and N terminals of an input pad should **not** be held at voltages lower than 2.4 V. A 100 Ω resistor is included internally, so no board termination is necessary.

Unused outputs do not need any termination, since they are terminated internally. This is valid for both powerdown mode and functional mode.

The pin LVDS_EN is an enable that overrides any processor control over the powerdown of the LVDS input and output pads. This is for boundary scan use only, and should be pulled high during functional mode. For boundary scan, LVDS_EN = 0 and HIZ_N = 1.

For board layout, LVDS traces should be run on controlled impedance layers, and should be specified as 50 Ω line-to-ground. The LVDS buffers support point-to-point connections. They are not intended for bussed implementations.

LVDS I/O (continued)

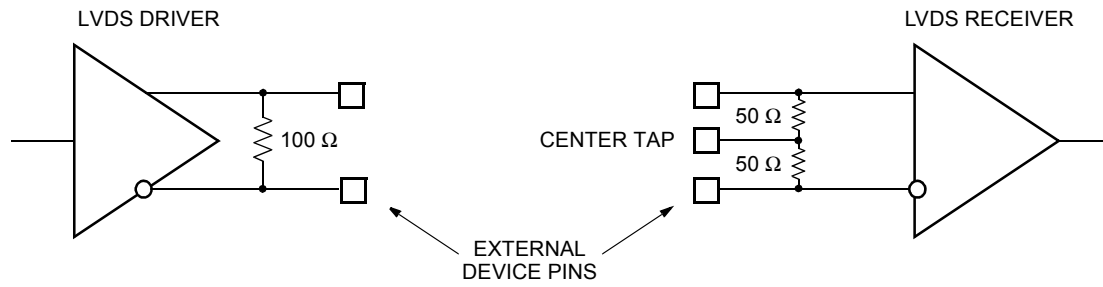

Figure 11. LVDS Driver and Receiver and Associated Internal Components

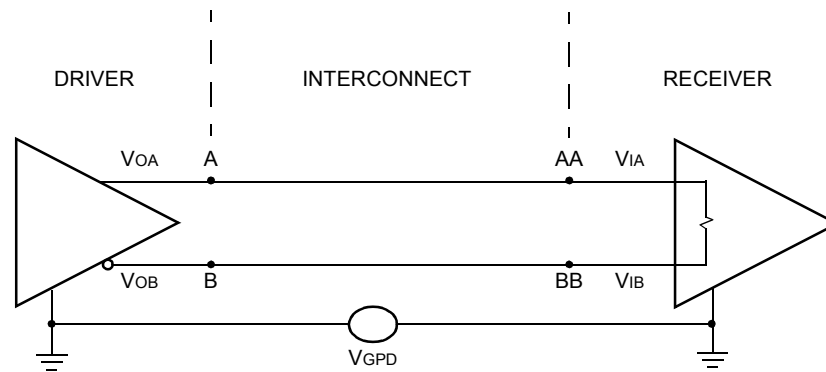

Figure 12. LVDS Driver and Receiver

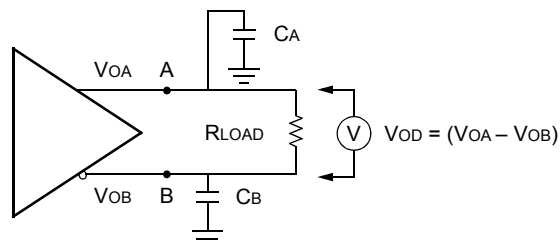

Figure 13. LVDS Driver

LVDS I/O (continued)

LVDS Receiver Buffer Capabilities

A disabled or unpowered LVDS receiver can withstand a driving LVDS transmitter over the full range of driver operating range, for an unlimited period of time, without being damaged. Table 16 illustrates LVDS driver dc data, Table 17 the ac data, and Table 14 on page 52 and Table 15 on page 52 the LVDS receiver data.

Table 14. LVDS Receiver dc Data*

Parameter	Symbol	Conditions	Min	Typ	Max	Unit
Input Voltage Range, V_{IA} or V_{IB} (Common-Mode Voltage)	V_I	$ V_{GPD} < 925 \text{ mV}$ dc – 1 MHz	0	1.2	2.4	V
Input Differential Threshold (Differential-Mode Voltage)	V_{IDTH}	$ V_{GPD} < 925 \text{ mV}$ 800 MHz	-100	—	100	mV
Input Differential Hysteresis	V_{HYST}	$(+V_{IDTHH}) - (-V_{IDTHL})$	—	—	— [†]	mV
Receiver Differential Input Impedance	R_{IN}	With Build-In Termination, Center-Tapped	80	100	120	Ω

* $V_{DD} = 3.1 \text{ V} - 3.5 \text{ V}$, $0 \text{ }^\circ\text{C} - 125 \text{ }^\circ\text{C}$, slow—fast process.

† Buffer will not produce output transition when input is open-circuited.

Table 15. LVDS Receiver ac Data*

Parameter	Symbol	Conditions	Min	Max	Unit
Rise Time (20%—80%)	t_R	$C_L = 1.5 \text{ pF}$	50	150	ps
Fall Time (80%—20%)	t_F	$C_L = 1.5 \text{ pF}$	50	150	ps

* $V_{DD} = 3.1 \text{ V} - 3.5 \text{ V}$, $0 \text{ }^\circ\text{C} - 125 \text{ }^\circ\text{C}$, slow—fast process.

LVDS I/O (continued)

Table 16. LVDS Driver dc Data*

Parameter	Symbol	Conditions	Min	Typ	Max	Unit
Output Voltage High, VOA or VOB	VOH	RLOAD = 100 Ω ± 1%	—	—	1.475 [†]	V
Output Voltage Low, VOA or VOB	VOL	RLOAD = 100 Ω ± 1%	0.925 [†]	—	—	V
Output Differential Voltage	VOD	RLOAD = 100 Ω ± 1%	0.25	—	0.45 [†]	V
Output Offset Voltage	VOS	RLOAD = 100 Ω ± 1%	1.125 [†]	—	1.275 [†]	V
Output Impedance, Signal Ended	Ro	VCM = 1.0 V and 1.4 V	40	50	60	Ω
Ro Mismatch Between A and B	ΔRo	VCM = 1.0 V and 1.4 V	—	—	10	%
Change in Differential Voltage Between Complementary States	ΔVOD	RLOAD = 100 Ω ± 1%	—	—	25	mV
Change in Output Offset Voltage Between Complementary States	ΔVOS	RLOAD = 100 Ω ± 1%	—	—	25	mV
Output Current	ISA, ISB	Driver Shorted to GND	—	—	24	mA
Output Current	ISAB	Drivers Shorted Together	—	—	12	mA
Power-Off Output Leakage	Ixa , Ixb	VDD = 0 V VPAD, VPADN = 0 V—3 V	—	—	30	μA

* VDD = 3.1 V—3.5 V, 0 °C—125 °C, slow—fast process.

† External references selected (CNT = 0), REF10 = 1.0 V ± 3%, REF14 = 1.4 V ± 3%.

Table 17. LVDS Driver ac Data*

Parameter	Symbol	Conditions	Min	Max	Unit
VOD Fall Time, 80%—20%	tF	ZL = 100 Ω ± 1% CPAD = 3.0 pF, CPADN = 3.0 pF	100	200	ps
VOD Rise Time, 20%—80%	tR	ZL = 100 Ω ± 1% CPAD = 3.0 pF, CPADN = 3.0 pF	100	200	ps
Differential Skew tPHLA – tPHLB or TPhLB – TPLHA	tsKEW1	Any Differential Pair on Package at the 50% Point of the Transition	—	50	ps

* VDD = 3.1 V—3.5 V, 0 °C—125 °C, slow—fast process.

Table 18. LVDS Driver Reference Data

Parameter	Conditions	Min	Typ	Max	Unit
REF10 Voltage Range	—	0.95	1.0	1.05	V
REF14 Voltage Range	—	1.35	1.4	1.45	V
Nominal Input Current— REF10 and REF14 Reference Inputs	—	—	10	—	μA

Clock and Data Recovery (CDR)

The following specifications are in reference to the clock and data recovery macro that is used for the backplane interface on the TTSV02622 chip.

Input Data

- 622 Mbits/s scrambled data stream conforms to SONET STS-12 and SDH STM-4 data format using either a PN7 or PN9 sequence. The PN7 characteristic is $1 + x^6 + x^7$ and The PN9 characteristic is $1 + x^4 + x^9$.
- Longest stream of nontransitional 622 Mbits/s input data is 60 bits. This sequence should not occur more often than once per minute.
- Input signal phase change of no more than 100 ps over 200 ns time interval, which translates to a frequency change of 500 ppm.
- Eye opening greater than 0.4 Ulp-p. Unit interval for 622 Mbits/s is 1.6075 ns.

Jitter Tolerance

Table 19. Jitter Tolerance

Frequency	Ulp-p
250 kHz	0.6
25 kHz	6.0
2 kHz	60

Generated Output Jitter

- 0.2 Ulp-p from 250 kHz to 5 MHz as measured on a spectrum analyzer.

PLL

- Loop bandwidth of less than 6 MHz.
- Jitter peaking of less than 2 dB.
- Minimum powerup reset duration of 10 μ s.
- Maximum lock acquisition of less than 1 ms.
- External 10 k Ω resistor to ground required.

Input Reference Clock

- Frequency deviation of no more than ± 20 ppm.
- Phase change of no more than 100 ps in 200 ns.
- Time interval that translates to a frequency change of 500 ppm.
- Input reference clock of 77.76 MHz.

Timing Characteristics

All timing numbers are measured relative to 1.5 V.

All outputs are driving 35 pF maximum, 5 pF minimum, except DB pins which drive 100 pF.

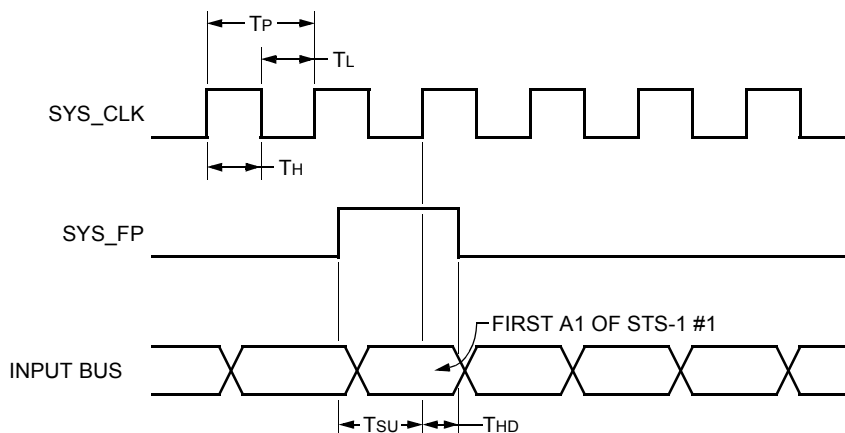

Figure 14. Input Parallel Port Timing

Table 20. Input Parallel Port Timing Requirements

Symbol	Parameter	Min	Typ	Max	Unit
T_P	Clock Period	—	12.86	—	ns
T_L	Clock Low Time	5.1	—	7.7	ns
T_H	Clock High Time	5.1	—	7.7	ns
T_{SU}	Data Setup Time	3	—	—	ns
T_{HD}	Data Hold Time	0	—	—	ns

Timing Characteristics (continued)

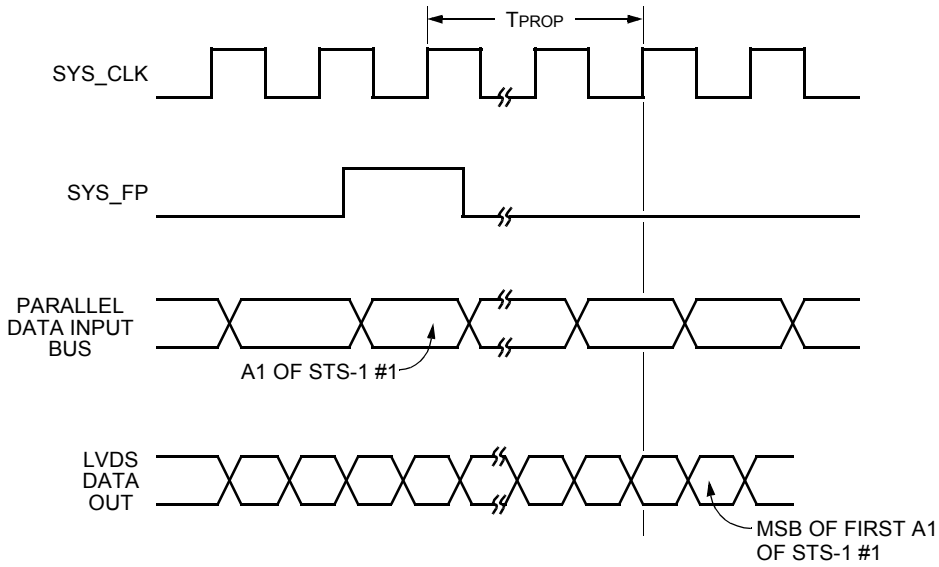

Figure 15. Transmitter Transport Delay

Table 21. Transmitter Transport Delay Timing Requirements

Symbol	Parameter	Typ	Unit
T _{PROP}	Number of Clocks of Delay from Parallel Bus Input to LVDS Output	7	SYS_CLK

Notes:
 LVDS data transmitted MSB first.
 Min/max variation due to clock phase selected in clock recovery block.

Timing Characteristics (continued)

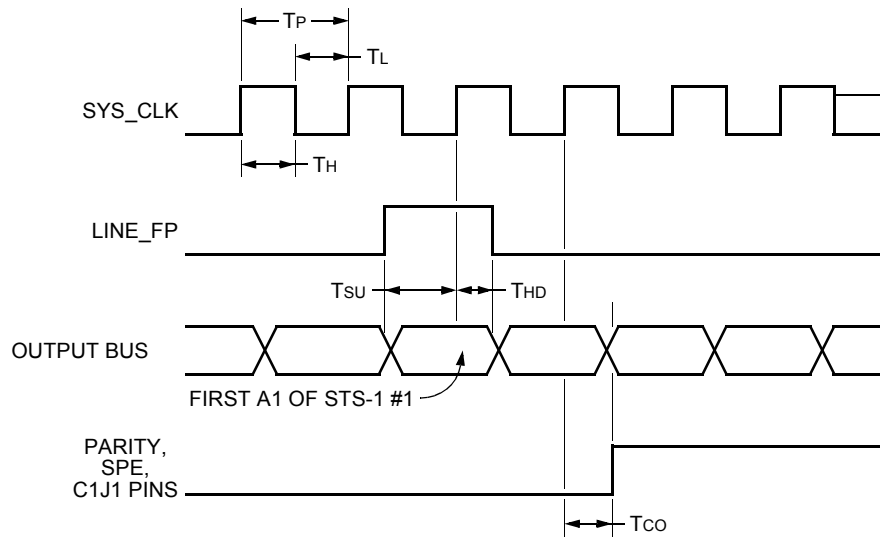

Figure 16. Output Parallel Port Timing

Table 22. Output Parallel Port Timing Requirements

Symbol	Parameter	Min	Typ	Max	Unit
TP	Clock Period	—	12.86	—	ns
TL	Clock Low Time	5.1	6.43	7.7	ns
TH	Clock High Time	5.1	6.43	7.7	ns
TSU	Data Setup Time	3	—	—	ns
THD	Data Hold Time	0	—	—	ns
TCO	Clock to Output Time of Data, Parity, SPE, and C1J1 Pins	1.3	—	7	ns

Note: Min TCO number is calculated based on 5 pF load. Max TCO is calculated based on 35 pF load.

Timing Characteristics (continued)

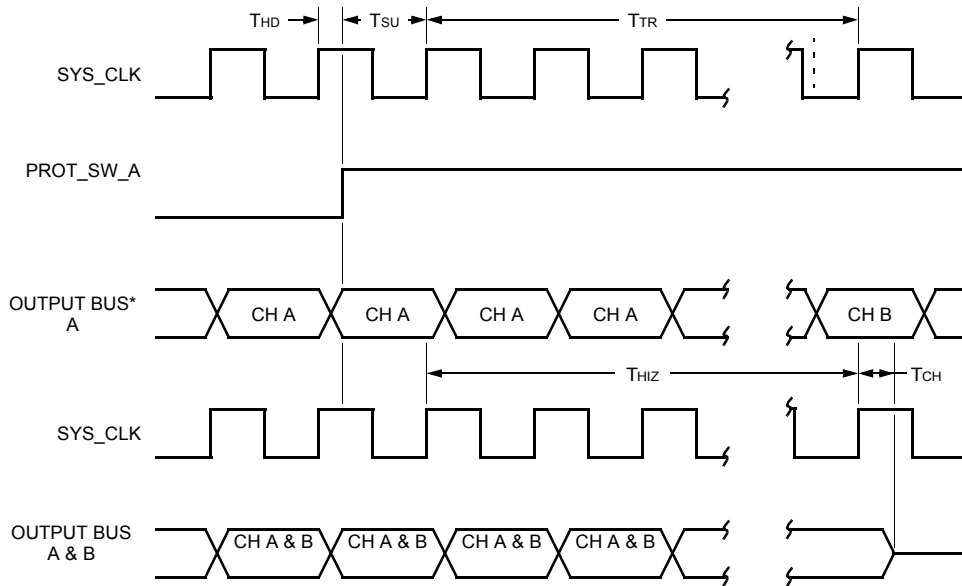

Figure 17. Protection Switch Timing

Table 23. Protection Switch Timing Requirements

Symbol	Parameter	Min	Typ	Max	Unit
TTR	Transport Delay from Latching of PROT_SW_A to Actual Data Switch	—	8	—	Leading edge SYS_CLKs
THIZ	Transport Delay from Latching of PROT_SW_A to Actual Data HI-Z	—	5	—	Leading edge SYS_CLKs
TCH	Propagation Delay from SYS_CLK to HI_Z of Output Bus	—	—	25	ns
TSU	Setup Time Required from Change in PROT_SW_A to Rising SYS_CLK	3	—	—	ns
THD	Hold Time Required from Rising SYS_CLK to Change in PROT_SW_A	0	—	—	ns

Notes:

Output bus refers to 8 bits data, 1 bit parity, 1 bit SPE, and 1 bit C1J1.

Channel A refers to whether the PROT_SW_A pins that are activated. For example, if the PROT_SW_A pin is activated, the timing diagram for output bus A refers to output bus A.

Min/max variation on TRT and THIZ due to clock phase selected in clock recovery block.

Timing Characteristics (continued)

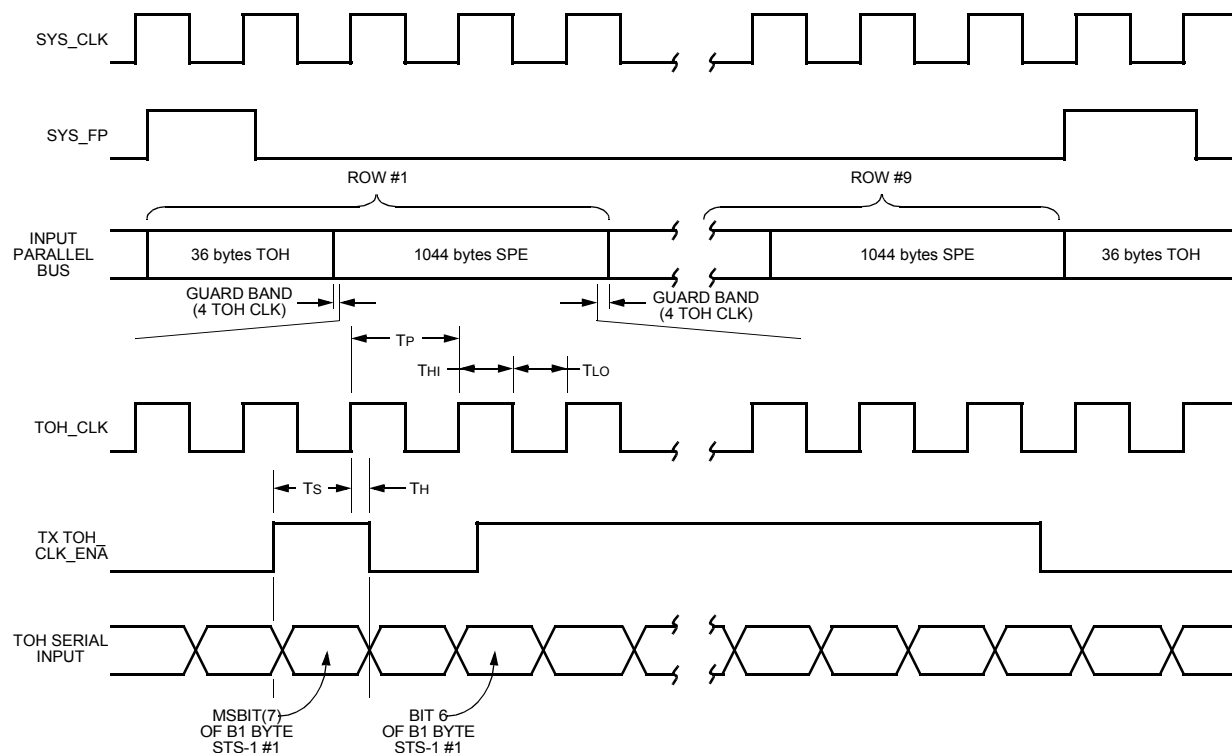

Figure 18. Input Serial Port Timing

Table 24. Input Serial Port Timing Requirements

Symbol	Parameter	Min	Typ	Max	Unit
TP	Clock Period	12.86	—	40	ns
THI	Clock High Time	5.1	—	24	ns
TLO	Clock Low Time	5.1	—	24	ns
Ts	Data Setup Time	3	—	—	ns
TH	Data Hold Time	0	—	—	ns

Timing Characteristics (continued)

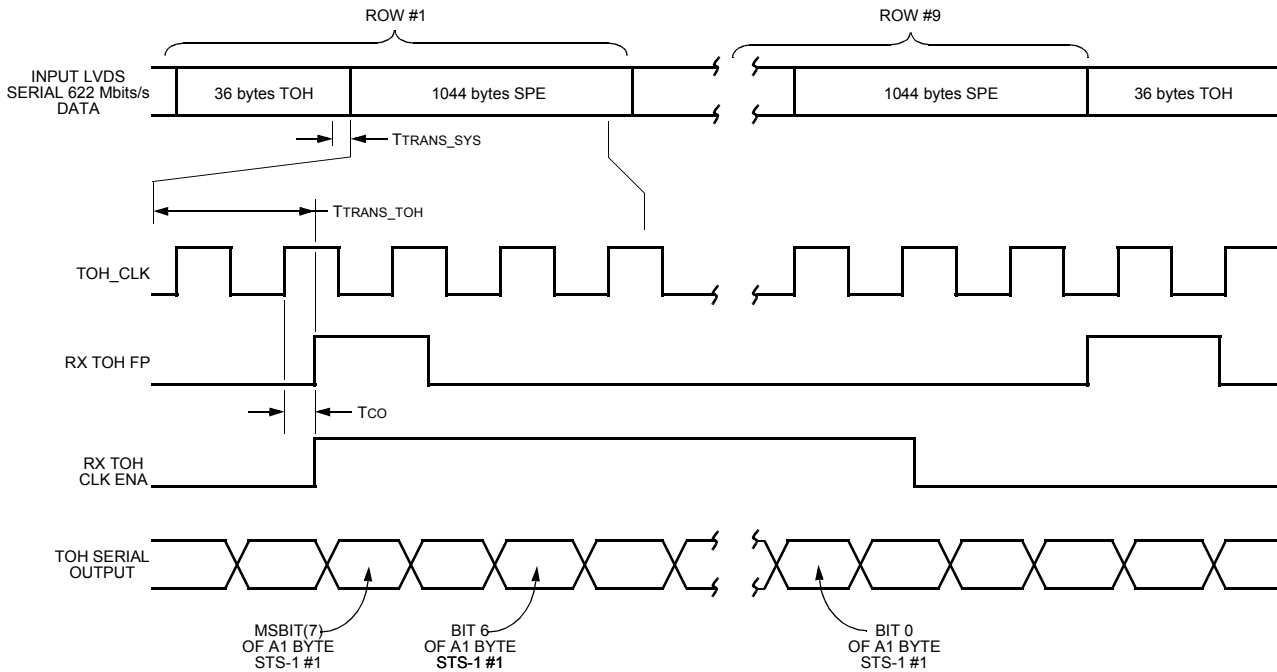

Figure 19. Output Serial Port Timing

Table 25. Output Serial Port Timing Requirements

Symbol	Parameter	Min	Typ	Max	Unit
Tco	Data Clock to Out	2	—	8	ns
TTRANS_SYS	Delay from First A1 LVDS Serial Input to Transfer to TOH_CLK	44	56	68	SYS_CLKs
TTRANS_TOH	Delay from Transfer to TOH_CLK to RX_TOH_FP	—	6	—	TOH_CLKs

Note: The total delay from A1 STS-1 #1 arriving at LVDS input to RX_TOH_FP is 56 SYS_CLKs, and 6 TOH_CLKs. This will vary by ±14 SYS_CLKs, 12 each way for the FIFO alignment, and ± 2 SYS_CLKs due to the variability in the clock recovery of the CDR macro.

Timing Characteristics (continued)

CPU Interface Timing

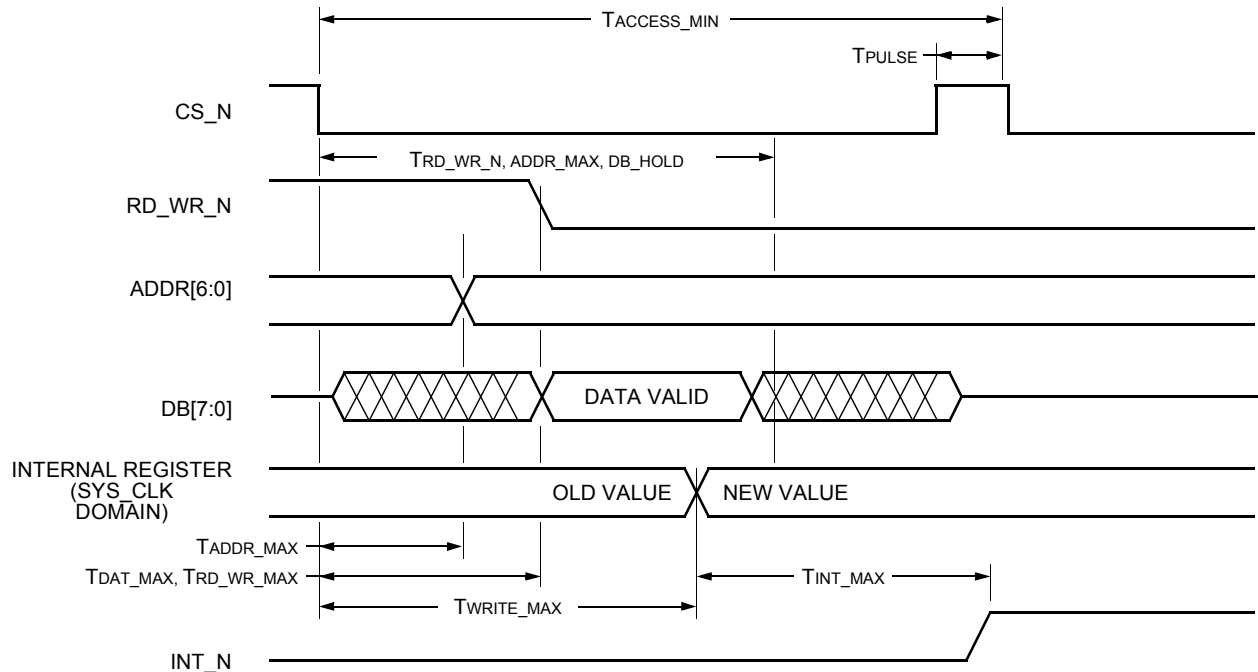

Figure 20. Write Transaction

Table 26. Write Transaction Timing Requirements

Symbol	Parameter	Min	Max	Unit
T_{PULSE}	Minimum Pulse Width for CS_N	5	—	ns
T_{ADDR_MAX}	Maximum Time from Negative Edge of CS_N to ADDR Valid	—	18	ns
T_{DAT_MAX}	Maximum Time from Negative Edge of CS_N to Data Valid	—	25	ns
$T_{RD_WR_MAX}$	Maximum Time from Negative Edge of CS_N to Negative Edge of RD_WR_N	—	26	ns
T_{WRITE_MAX}	Maximum Time from Negative Edge of CS_N to Contents of Internal Register Latching DB[7:0]	—	60	ns
T_{ACCESS_MIN}	Minimum Time Between a Write Cycle (falling edge of CS_N) and Any other Transaction (read or write, at falling edge of CS_N)	60	—	ns
T_{INT_MAX}	Maximum Time from Register FF to Pad	—	20	ns
$T_{RD_WR_N}, ADDR_MAX, DB_HOLD$	Minimum Hold Time that RD_WR_N, ADDR, and DB Must Be Held Valid from the Negative Edge of CS_N	57	—	ns

Timing Characteristics (continued)

CPU Interface Timing (continued)

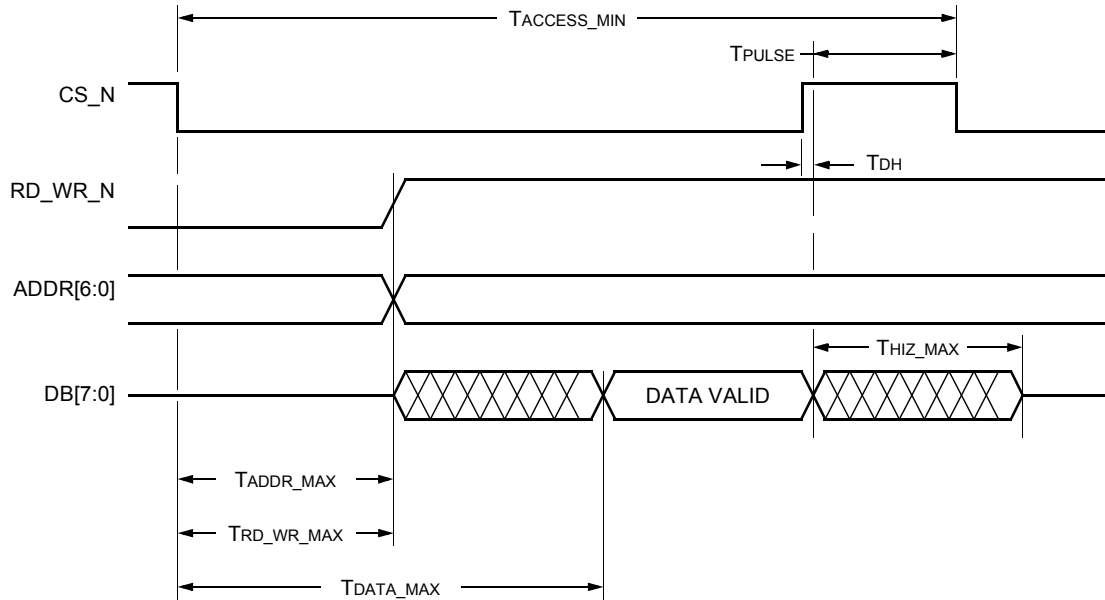

Figure 21. Read Transaction

Table 27. Read Transaction Timing Requirements

Symbol	Parameter	Min	Max	Unit
TPULSE	Minimum Pulse Width for CS_N	5	—	ns
TADDR_MAX	Maximum Time from Negative Edge of CS_N to Addr Valid	—	5	ns
TRD_WR_MAX	Maximum Time from Negative Edge of CS_N to RD_WR_N Rising	—	5	ns
TDATA_MAX	Maximum Time from Negative Edge of CS_N to Data Valid on DB Port	—	56	ns
THIZ_MAX	Maximum Time from Rising Edge of CS_N to DB Port Going HI-Z	—	12	ns
TDH	Data Hold Time After CS_N Is Deasserted	0	—	ns
TACCESS_MIN	Minimum Time Between a Read Cycle (falling edge of CS_N) and Any Other Transaction (read or write, at falling edge of CS_N)	60	—	ns

Outline Diagram

272-Pin PBGA

Dimensions are in millimeters.

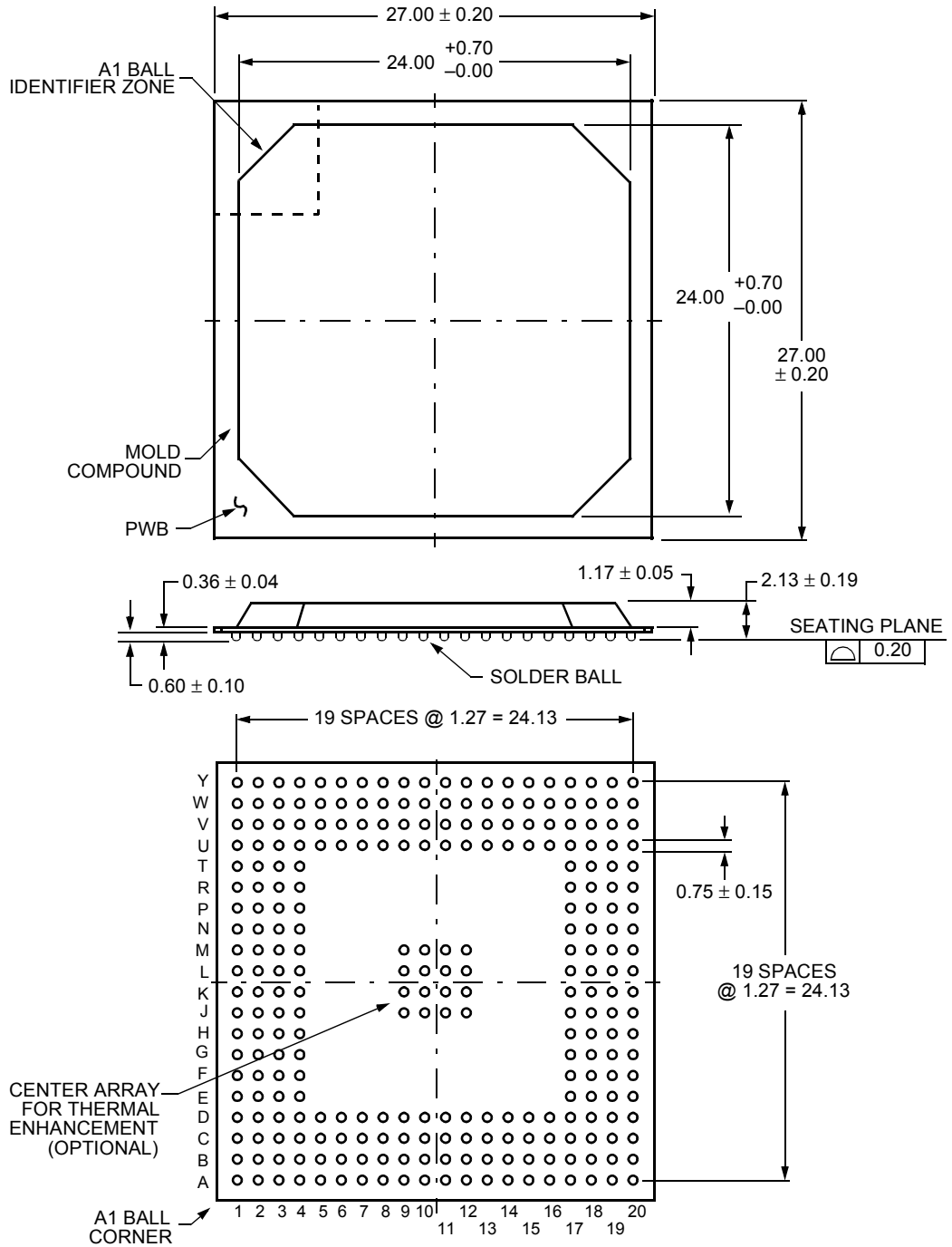

Ordering Information

Device Code	Package	Temperature	Comcode (Ordering Number)
TTSV02622V2-DB	272-pin PBGA	-40 °C to +125 °C	700034617

For additional information, contact your Agere Systems Account Manager or the following:

INTERNET: <http://www.agere.com>

E-MAIL: docmaster@agere.com

N. AMERICA: Agere Systems Inc., Lehigh Valley Central Campus, Room 10A-301C, 1110 American Parkway NE, Allentown, PA 18109-9138
1-800-372-2447, FAX 610-712-4106 (In CANADA: **1-800-553-2448**, FAX 610-712-4106)

ASIA: Agere Systems Hong Kong Ltd., Suites 3201 & 3210-12, 32/F, Tower 2, The Gateway, Harbour City, Kowloon

Tel. **(852) 3129-2000**, FAX (852) 3129-2020

CHINA: **(86) 21-5047-1212** (Shanghai), **(86) 755-25881122** (Shenzhen)

JAPAN: **(81) 3-5421-1600** (Tokyo), KOREA: **(82) 2-767-1850** (Seoul), SINGAPORE: **(65) 6778-8833**, TAIWAN: **(886) 2-2725-5858** (Taipei)

EUROPE: Tel. **(44) 1344 296 400**

Agere Systems Inc. reserves the right to make changes to the product(s) or information contained herein without notice. No liability is assumed as a result of their use or application. Agere, Agere Systems, and the Agere Logo are trademarks of Agere Systems Inc.