

HA16808ANT

Speech Network IC including Speaker Amp. for Telephone Set

Description

The HA16808ANT is a monolithic IC including speech network, tone ringer, and speaker amp.

Therefore the telephone with speaker can be composed of HA16808ANT and dialer IC.

Features

- Low voltage operation (1.8V)
- AGC according to the line current (Gains of sending, receiving, DTMF, and melody)
- Adjustable receiving gain by external resistor (0 to +10dB)
- Interface for DTMF (V_{DD} , MUTE, Sending amp. of DTMF signal)
- Interface for melody IC (V_{DD} , Sending amp. of melody signal)
- Noise suppression (No output for the input below noise level. The noise level can be controlled by external components.)
- Possible to dial under the on – hook condition (Included speaker amp.)
- Possible to receive by speaker (Also possible to send with handset in speaker mode.)
- At the time to send DTMF or melody, back-tone comes out from receiver or speaker.
- Variable oscillation freq. of ringer by external R, C.
- Variable supply initiation current.
- 42 pins shrink plastic DIP package (DP-42SA)

Pin Description

Pin No.	Symbol	Function	Function	Symbol	Pin No.
1	MIC 1	Mic. Input	Hook Switch	HS	42
2	MIC 2		AGC	AGC	41
3	GND	Tone Ringer	Voice SW Gain Adjustment (Noise Suppression)	VS3	40
4	OUTPUT		Decide the Suppression Level (Speaker Receive)	VS4	39
5	V_{CC}		On at Speaker Mode	SP SW	38
6	LOW FREQ.		Detect the Line Current	ILDET	37
7	TIME CONSTANT		Bridge part 1	BRG1	36
8	HIGH FREQ.		Bridge part 2	BRG2	35
9	TIME CONSTANT		Loss Pad on Speaker mode	ALC	34
10	R_{SL}		NC	NC	33
11	MUTE	DTMF Mode ($\geq 1.6V$)	Regulating Capacitor	BIPS	32
12	HOLD	On at Melody Mode	Speaker Amp. GND	GND 2	31
13	R_B	Decide IC Bias Current	Line	L1	30
14	GRCT	Adjust Receiving Gain	Speaker Part Regulator	V_{SP}	29
15	BRG3	Receiving Signal Input (one part of the bridge)	Compensating Capacitor	COMP1	28
16	BRG4		Speaker Amp. Output	SP OUT	27
17	MEL	Melody Input	Speaker Amp. Input	SP IN	26
18	V_{REF2}	Melody IC Supply Voltage	Buffer Amp. Output	BUFF OUT	25
19	DTMF	DTMF Input	Buffer Amp. Input	BUFF IN	24
20	V_{REF1}	DTMF IC Supply Voltage	Receiver Output	REC1	23
21	L2	Line (GND)		REC2	22



Block Diagram

2

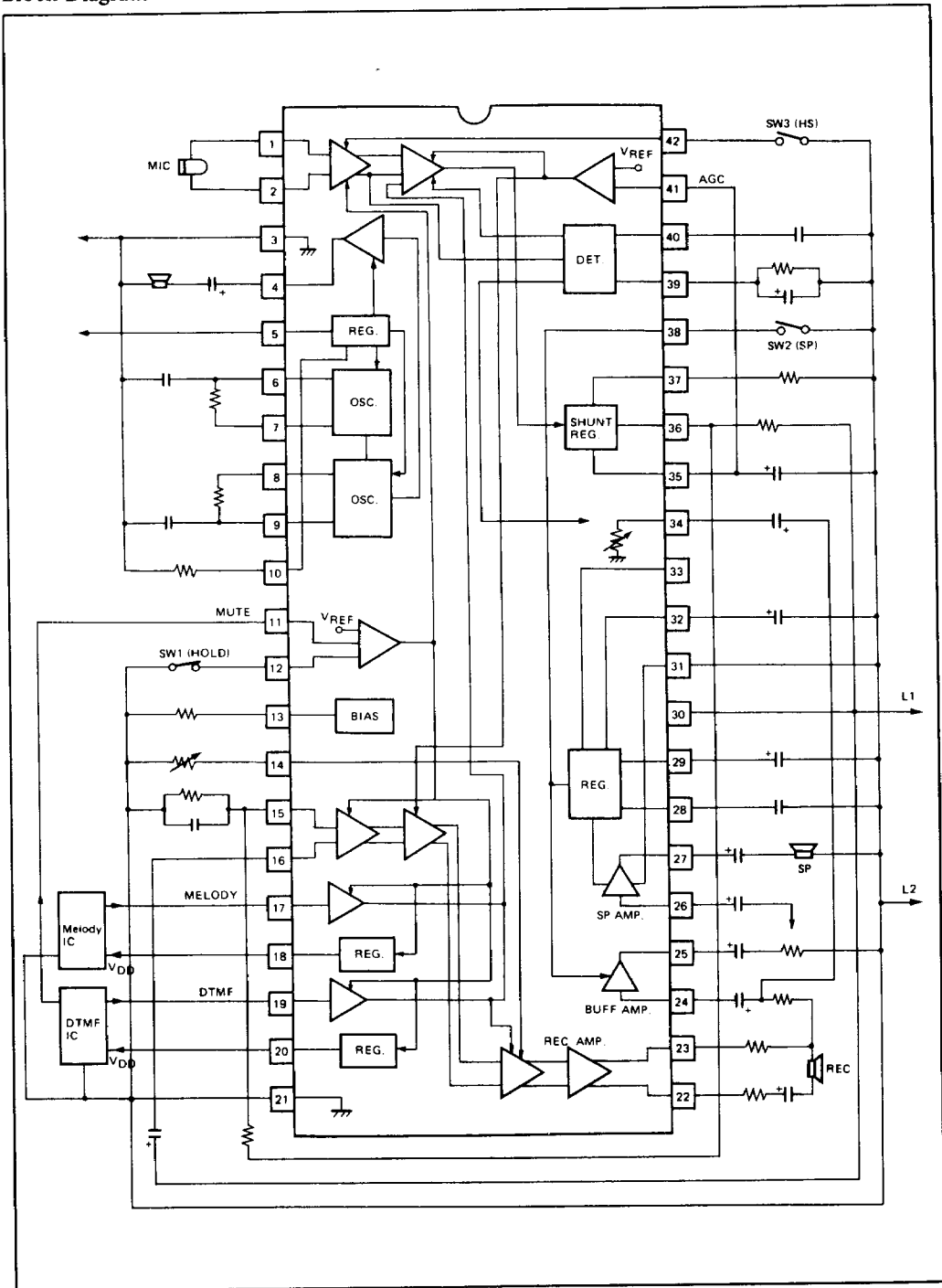

Functional Description

• **DTMF IF**

When 11 pin (MUTE) voltage V_{11} is 1.6V or more, IC becomes DTMF sending mode. (Threshold level is 1.3V typ). In this mode, the sending and receiving input amps are 'off' and DTMF sending amp. is 'on'.

Though DTMF signal is applied to 19 pin then, AC couple is needed (Cex16) because of bias of

about 1V.

50 to 70mVrms input level is appropriate because the sending gain is a little over 20dB. As soon as DTMF signal is sent to line, backtone is produced from receiver. At speaker mode it is also from speaker. Also, DTMF IC supply voltage or current changes to V_{11} as figures.

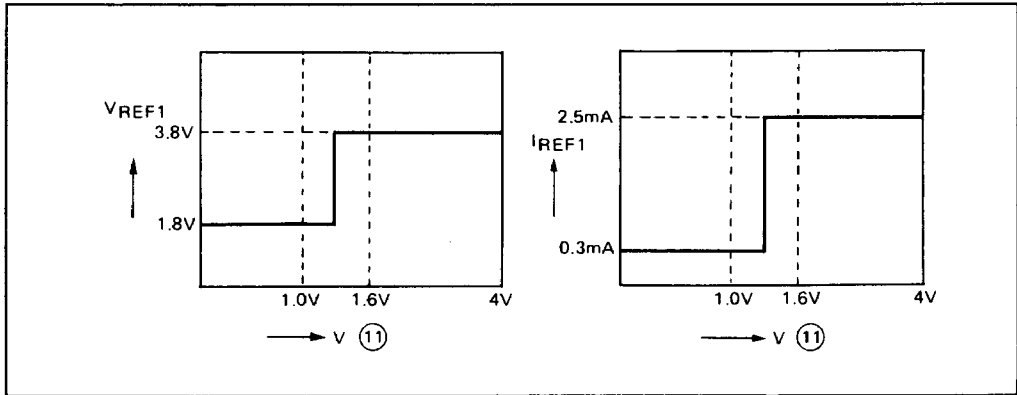

• **Hold IF**

When 12 pin (HOLD) is connected to GND, IC becomes hold mode, and sending and receiving input amps are 'off', and melody sending amp. is 'on'. As the melody is applied to 17 pin, AC couple (Cex15) is needed because of bias of about

1V. 10 to 30mVrms input level is appropriate because of a little over 20dB.

As soon as the melody is sent to line, the backtone is produced from speaker. Then, the melody IC supply source becomes 'on' for the first time.

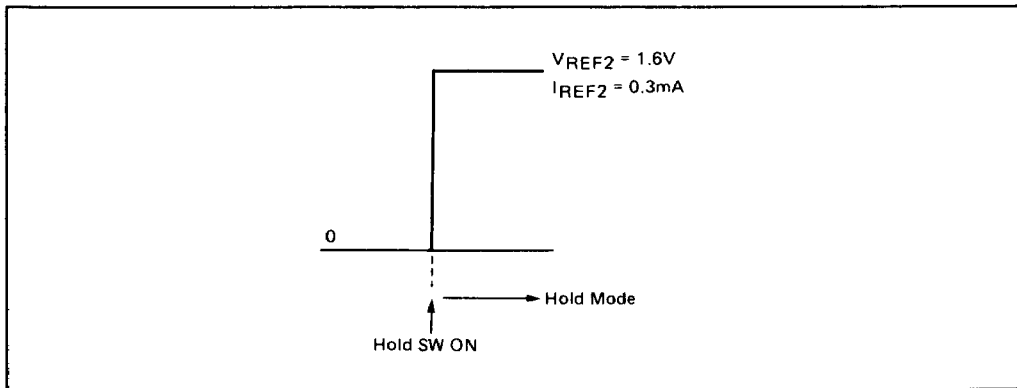

● **Circuit for suppression of sidetone**

The circuit for suppression of sidetone is constructed by resistance bridge. To control sidetone Z_B is adjusted, in consideration of the line impedance Z_L .

$$\frac{R_{ex8}}{R_{ex15}} = \frac{Z_B}{Z_L}$$

Cex5 is for AC couple.

When the resistance increases with keeping the ratio of R_{ex8}/R_{ex15} , the receiving gain increases. The receiving gain of $R_{ex8}/R_{ex15} = 330\Omega/30\Omega$ gets about 6dB larger than that of $110\Omega/10\Omega$.

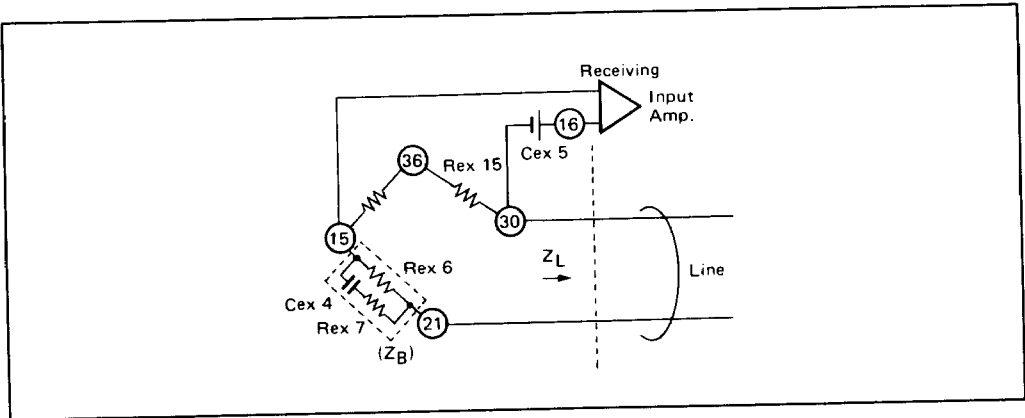

● **Receiving Gain Variable**

When the R_{ex5} decreases, the receiving gain increases while receiving (But $R_{ex5} \geq 560\Omega$). When $R_{ex5} = 1k\Omega$ to the condition of open of 14 pin, the receiving gain increases by about 8dB. Moreover, some modes are automatically 'off'.

Mode	Speaking		Dial (DTMF Sending)	Hold
	Hand Set	Speaker		
On	○	○	x	x
Off	x			

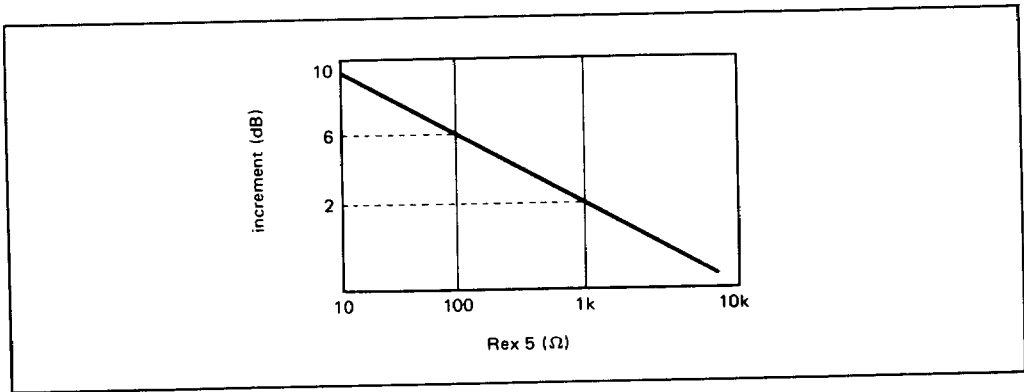

• AGC Characteristics (Line Compensation)

By connecting 41 pin with 35 pin, the sending and receiving gain, and the DTMF and Melody amp. are automatically adjusted to line current. When 41 pin applied voltage is fixed with aparting 41 pin from 35 pin, the gain becomes

fixed,

High gain fix when $0V \leq V_{41} \leq 0.3V$

Low gain fix when $V_{41} = V_{30}$ or open

In the case of $30mA \leq I_L \leq 70mA$, the gain changes.

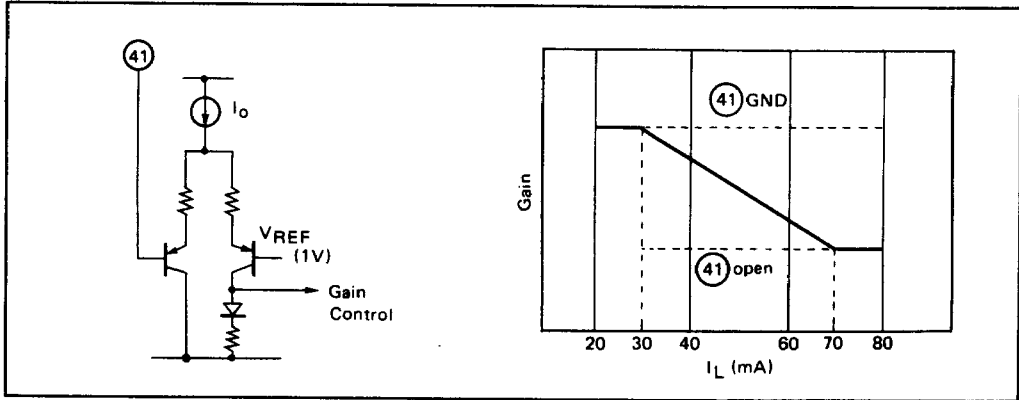

• Receiving by speaker

When 38 pin (SPSW) is connected to GND, the IC becomes speaker mode, and in this mode, buffer-amp., speaker amp. and the regulator (V_{sp}) are 'on'. By inserting volume it is possible to adjust the volume of speaker output. Voltage of V_{sp} changes the line current I_L and

secures the dynamic range at line. (L1)

In $20mA \leq I_L \leq 50mA$, V_{sp} changes from 2V to 3V, in $I_L \geq 50mA$ it keeps 3V. Also the line voltage is 1.5V higher than normal mode. (at $I_L = 20mA$).

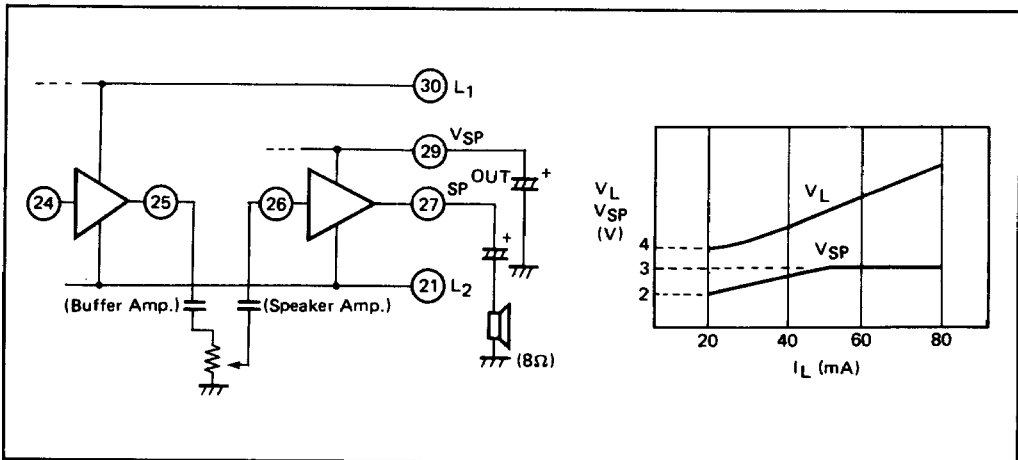

● Speaking at speaker mode

At speaker Mode it is possible to call under the holding Off-Hook. But when a signal enters from mike, speaker output attenuates by about -40dB because of keeping away the oscillation of speaker and mike of hand set, what is called, the howling. So the sound of speaker disappears, but from the receiver of hand set, the sound can be normally

heard. The threshold of mike input can be adjusted by Cex19 in the same way as noise suppression. The rising time T_{up} and the hang over time T_h of the change of speaking and receiving are determined by Rex17 and Cex18 of 39 pin.

$$T_{up} = 13 \text{ Cex18 [ms]}$$

$$T_h = \text{Cex18} \cdot \text{Rex17 [ms]}$$

2

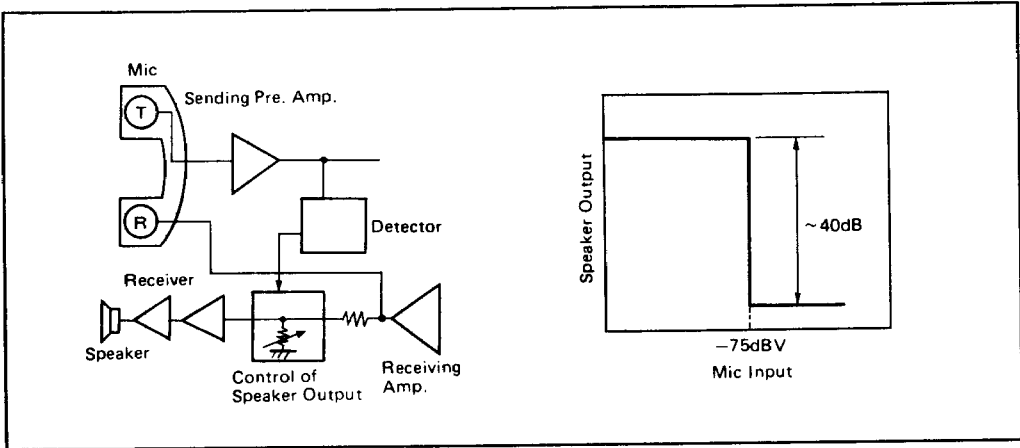
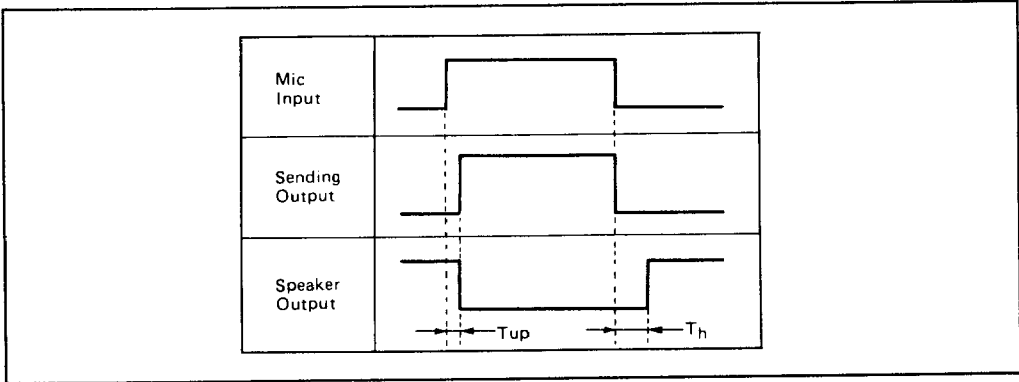

● Hook Switch (HS)

As 42 pin interlocks with the hook switch, in the case of GND the sending preamp. is 'on' and in the case of open it is 'off' and the signal from mike is not amplified.

● Backtone I_L margin Up

While the on-hook dialing (speaker mode), the backtone is produced from speaker. Under the condition of $I_L \leq 25\text{mA}$ the sound from speaker becomes little.

By using MUTE signal and adding a circuit, the

margin increases. 13 pin is biased under the condition of 1V, the constant-current is determined by external Rex4. When MUTE becomes high level, V_{REF1} changes from 1.8V typ. to 3.8V typ., constant-current decreases equivalently, and I_L margin increases.

Moreover, when 33 pin is set by 'L' level ($0.5V \leq$), V_{sp} is fixed, and dynamic range of speaker amp. widens when dialing, that is, sending DTMF signal, V_{sp} can be fixed because of going the line voltage up to 6V.

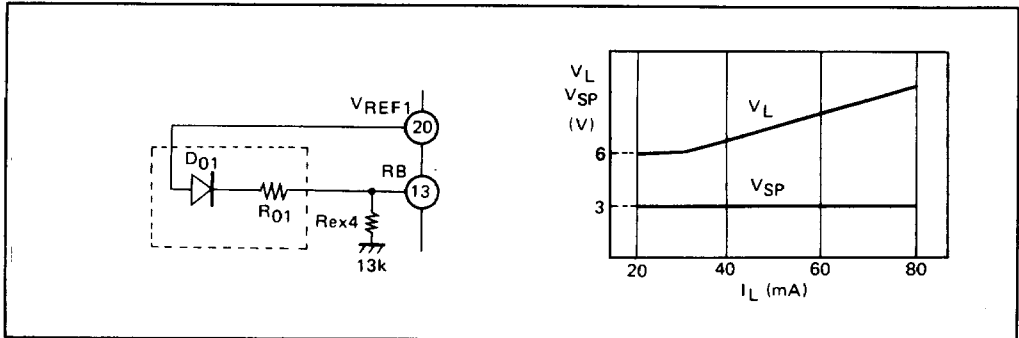

● Keytone Amp.

In the case of using the pulse dialer keytone is produced as backtone as pushing dial. Then, the speaker amp. can be used as a keytone amp. When power supply is applied to V_{sp} (29 pin) by a zener diode, speaker amp. operates independent of

other circuits.

The speaker amp. can operate under the condition of 1.5V or more. When the keytone signal is applied to 26 pin, the keytone is confirmed by speaker.

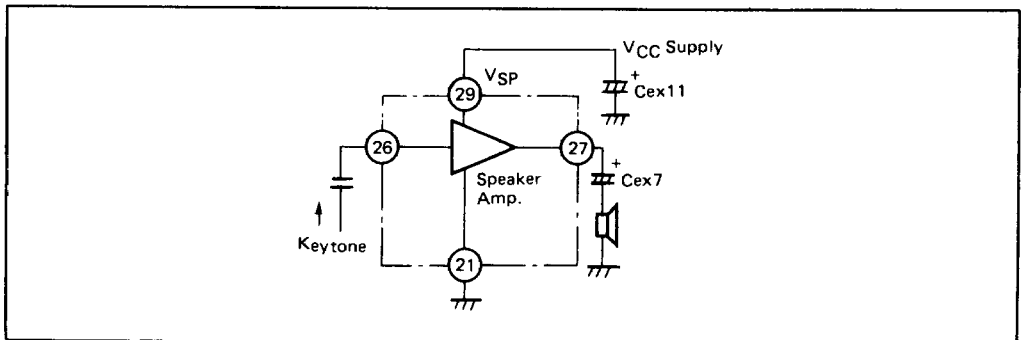

● **Line Current Detection**

The current in proportion to the Line current flows to Rex16 via 37 pin, and the line current is detected by this voltage. The voltage of 35 pin adds this voltage to +0.3V.

$$V_{35} = V_{37} + 0.3V$$

Moreover, the line matching impedance is proportioned to this Rex16. $Z_{IN} \propto \text{Rex16}$

● **Tone Ringer Oscillation Frequency**

Construction of toner system is same as that of the HA16805PS (toner ringer). The oscillator (1) has low frequency oscillation of about 10Hz, and the oscillator (2) is demodulated by this frequency; f_L . The oscillator (2) has two oscillation frequency; f_{H1} and f_{H2} by the oscillator (1).

$$f_L = 1/1.25 \cdot \text{Rex1} \cdot \text{Cex3}$$

$$f_{H1} = 1/1.35 \cdot \text{Rex2} \cdot \text{Cex3} \text{ (Hz)}$$

$$f_{H2} = 1.24 f_{H1} \text{ (Hz)}$$

2

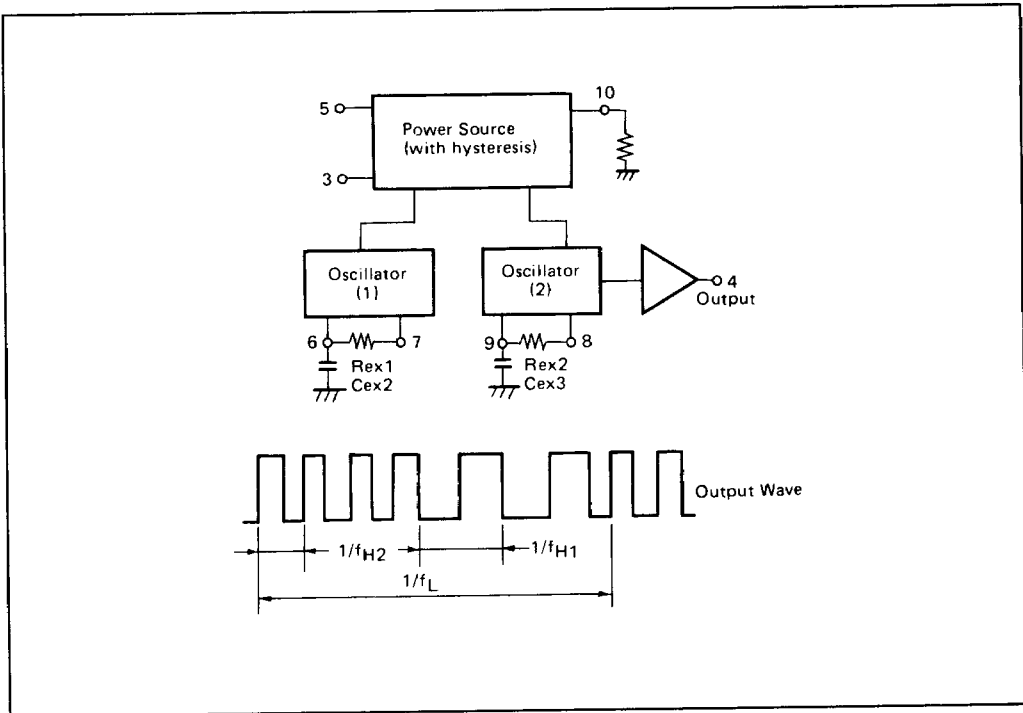

Absolute Maximum Ratings (Ta = 25°C)

Item	Symbol	Rating	Unit
Supply Voltage (OFF HOOK)	V_L^{*1}	20	V
Supply Current (OFF HOOK)	I_L	120	mA
Supply Voltage (Tone Ringer)	V_{TR}	30	V
Power Dissipation	P_T	950	mW
Operating Temperature	T_{opr}	-20 to +70	°C
Storage Temperature	T_{stg}	-55 to +125	°C

Note) *1 3ms Pulse duration

The absolute maximum ratings are limiting values, to be applied individually, beyond which the device may be permanently damaged. Functional operation under any of these conditions is not guaranteed. Exposing a circuit to its absolute maximum rating for extended periods of time may affect the device's reliability.

Electrical Characteristics

● Handset Mode

Item		Symbol	min.	typ.	max.	Unit	Test Condition	
							I_L (mA)	
Supply Voltage	Speaking	V_L	2.3	2.6	2.8	V	20	
			5.0	6.5	8.0	V	80	
	Dialing		5.5	6.2	6.6	V	20	
			7.0	—	10.0	V	80	
Receiving Gain		G_R	-6.5	-5	-3.5	dB	30	$f = 1\text{kHz}$
			-12.5	-11	-9.5	dB	80	
	Up Mode		5	10	15	dB	30	$R_{EXB_s} = 0\Omega$
Sending Gain		G_T	49.5	51	52.5	dB	30	$f = 1\text{kHz}$
			44	45.5	47	dB	80	
Side tone		G_{SID}	—	—	40	dB	30	$f = 1\text{kHz}$
DTMF Sending Gain		G_{MF}	20.5	22	23.5	dB	30	
			17	18.5	20	dB	80	
Sending Dynamic Range		DR_T	2.2	2.7	—	Vp-p	30	$f = 1\text{kHz}$
			4.5	6.0	—	Vp-p	80	
Receiving Dynamic Range		DR_R	0.4	0.6	—	Vp-p	20	$f = 1\text{kHz}$
			0.8	—	—	Vp-p	80	
DTMF Dynamic Range		DR_{MF}	2.8	4.0	—	Vp-p	20	
			3.0	—	—	Vp-p	80	
DTMF Supply Voltage	Stand-by	V_{DD}	1.6	1.8	—	V	20	
	Mute		3.5	3.8	—	V	20	
DTMF Supply Current	Stand-by	I_{DD}	200	—	—	μA	20	
	Mute		2	—	—	mA	20	
DTMF Backtone		BT_{MF}	60	85	110	mVp-p	80	$V_{IN} = 170\text{mVp-p}$
Line Matching Impedance		Z_{IN}	500	600	700	Ω	20, 80	$f = 1\text{kHz}$



● Speaker Mode

Item	Symbol	min.	typ.	max.	Unit	Test Condition		
						I_L (mA)		
Supply Voltage	Speaking	V_{LSP}	3.9	4.35	4.7	V	20	
			6	—	9	V	80	
	Dialing		5.2	6.0	6.8	V	20	
			7	—	10	V	80	
Receiving Gain	$GRSP$		-12.5	-10	-7.5	dB	30	$f = 1\text{kHz}$
			-17.5	-15	-12.5	dB	80	
Sending Gain	$GTSP$		46	48	50	dB	30	$f = 1\text{kHz}$
			40	42	44	dB	80	
Side tone	$GSIDSP$	—	—	45	dB	30	$f = 1\text{kHz}$	
DTMF Sending Gain	$GMFSP$		19.5	21.5	23.5	dB	30	
			16	18	20	dB	80	
Sending Dynamic Range	DR_{TSP}	2.3	—	—	V _{p-p}	50	$f = 1\text{kHz}$	
Receiving (SP) Dynamic Range	DR_{SP}	0.8	—	—	V _{p-p}	50	Speaker Output	
DTMF Dynamic Range	DR_{MFSP}	2.2	—	—	V _{p-p}	20		
DTMF Backtone	Receiver	BT_{MFSP}	40	65	90	mV _{p-p}	25	$V_{in} = 120\text{mV}_{p-p}$
	Speaker		400	550	700	mV _{p-p}	50	
Line Matching Impedance	Z_{INSP}	270	—	700	Ω	20, 80		
Speaker Amp. Gain	G_{SP}	5	8.5	12	dB	30		

● Melody Mode

Item	Symbol	min.	typ.	max.	Unit	Test Condition		
						I_L (mA)		
Supply Voltage	V_{LHD}		3.9	4.35	4.7	V	20	
			6	—	9	V	80	
Melody IC Supply	Voltage	V_{DH}	1.2	1.5	1.8	V	20	
	Current	I_{DH}	200	—	—	μA	20	
Melody Sending Gain	G_{HD}		22	24	26	dB	30	$f = 1\text{kHz}$
			19	21	23	dB	80	
Melody Sending Dynamic Range	DR_{HD}	2.2	—	—	V _{p-p}	30		
Melody Back tone	Receiver	BT_{HD}	30	60	90	mV _{p-p}	30	$f = 1\text{kHz}$
	Speaker		350	450	550	mV _{p-p}	30	$V_{in} = 70\text{mV}_{p-p}$

● Tone Ringer

Item	Symbol	min.	typ.	max.	Unit	Test Conditions
Supply Initiation Voltage	V_{TH}	17	19	21	V	
Supply Initiation Current	I_{TH}	0.7	1.5	3.0	mA	
Sustaining Voltage	V_{SUS}	9	11	—	V	
Sustaining Current	I_{SUS}	0.5	1.0	2.0	mA	$V_{in} = 15\text{V}$
Output "H" Voltage	V_{OH}	20.0	21.5	22.5	V	$V_{in} = 24\text{V}$, $I_{OH} = -10\text{mA}$
Output "L" Voltage	V_{OL}	0.7	1.0	2.0	V	$V_{in} = 24\text{V}$, $I_{OL} = 10\text{mA}$
Output Frequency	f_L	9	10	11	Hz	$R_1 = 165\text{k}\Omega$, $C_1 = 0.47\mu\text{F}$
	f_{H1}	460	510	565	Hz	$R_2 = 190\text{k}\Omega$, $C_2 = 6800\text{pF}$
	f_{H2}	575	640	705	Hz	$V_{in} = 24\text{V}$



Test Circuit

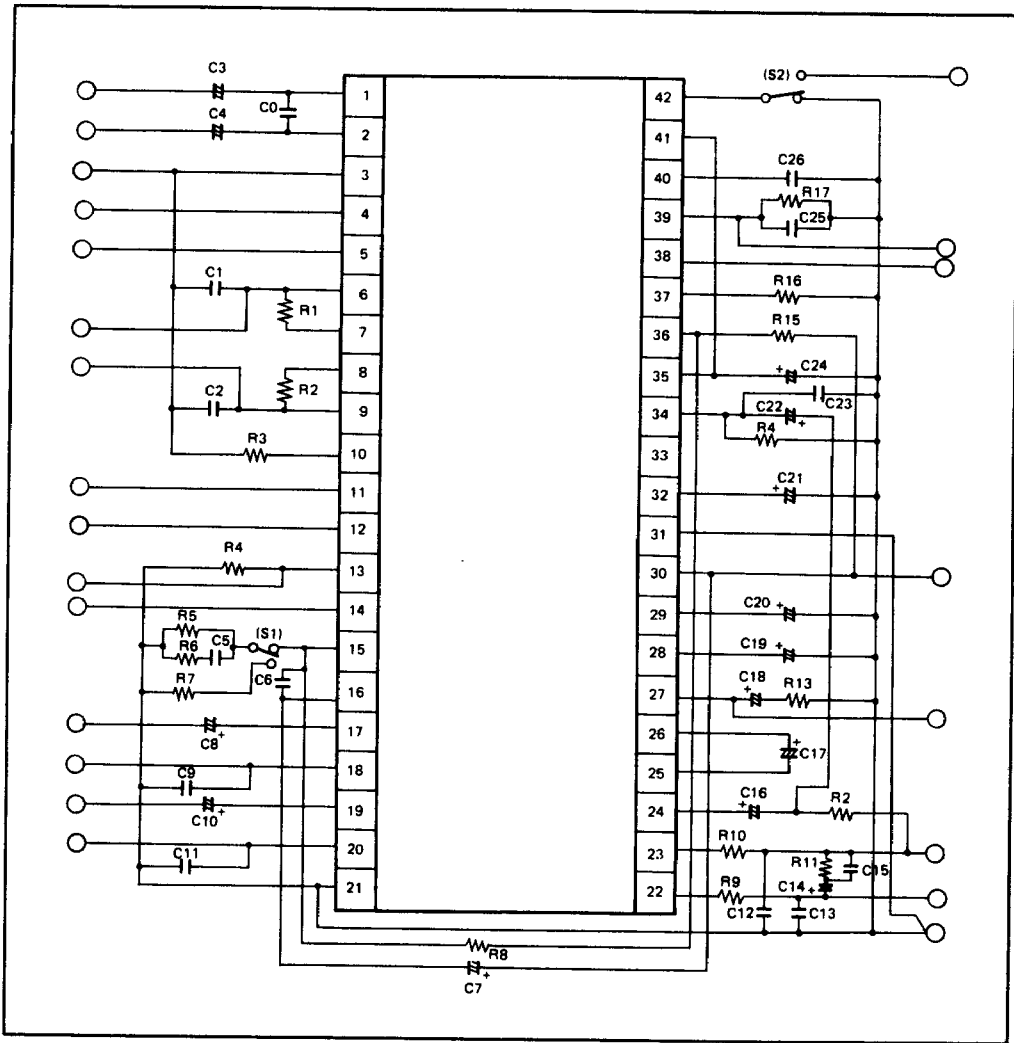

CNo.	C Value	CNo.	C Value	CNo.	C Value	CNo.	C Value	CNo.	C Value	CNo.	C Value
0	1000P	1	0.47μ	2	6800p	3	22μ	4	22μ	5	0.015μ
6	0.033μ	7	3.3μ	8	2.2μ	9	0.47μ	10	2.2μ	11	0.47μ
12	0.047μ	13	0.047μ	14	2.2μ	15	0.1μ	16	1μ	17	1μ
18	100μ	19	3.3μ	20	330μ	21	2.2μ	22	1μ	23	2200p
24	10μ	25	0.47μ	26	0.068μ						

RNo.	R Value	RNo.	R Value	RNo.	R Value	RNo.	R Value	RNo.	R Value	RNo.	R Value
1	165k	2	190k	3	13k	4	13k	5	13k	6	2.4k
7	12k	8	110	9	10	10	10	11	180	12	51k
13	8	14	510k	15	10	16	30	17	560k		

Unit R: Ω, C: F



Connection Arrangement and Application Circuit

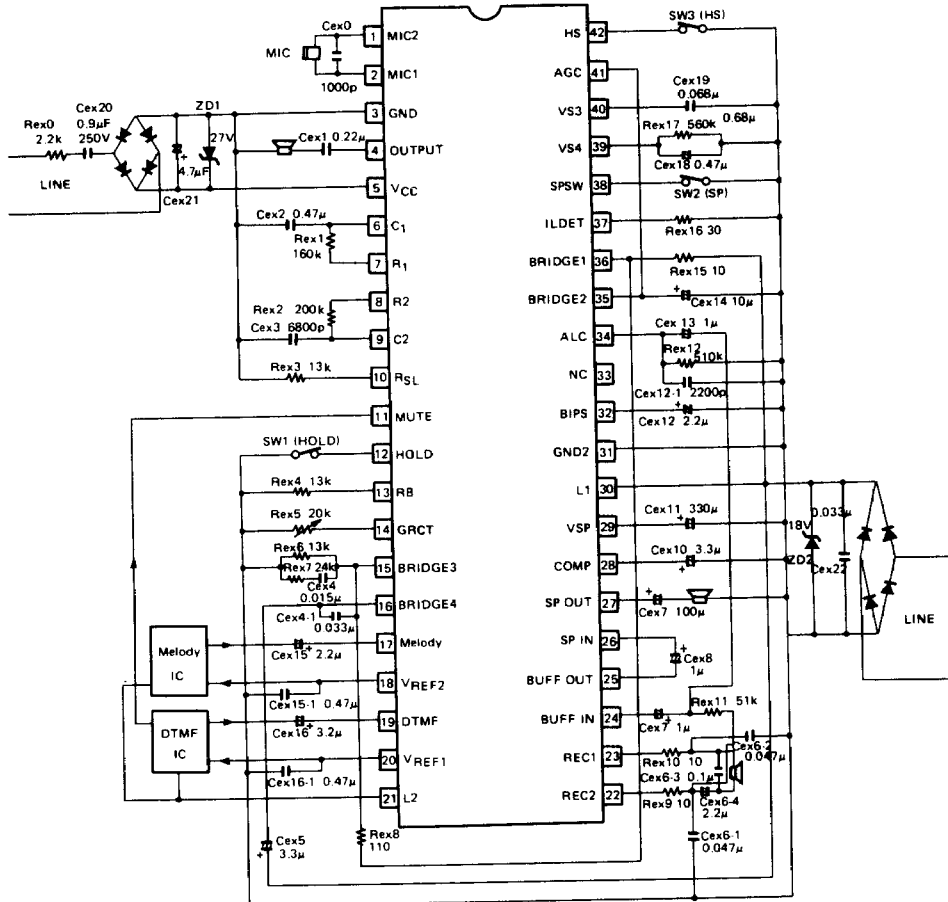

(TOP VIEW)

Note) Unit (R (Ω)
C (F))

External Components are only for reference.



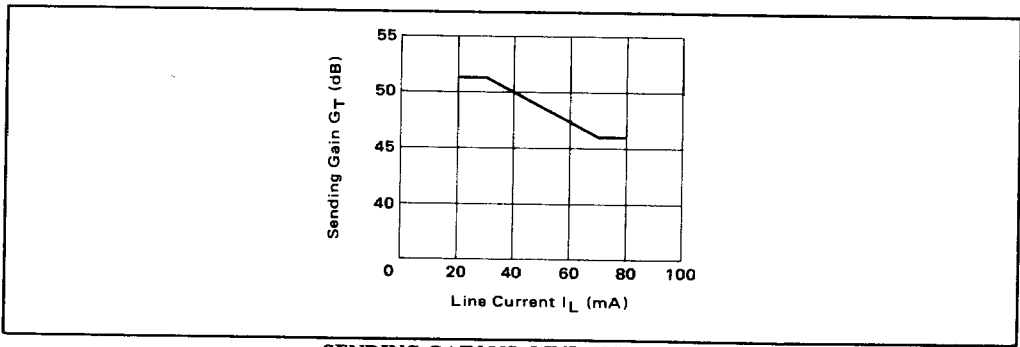

SENDING GAIN VS. LINE CURRENT

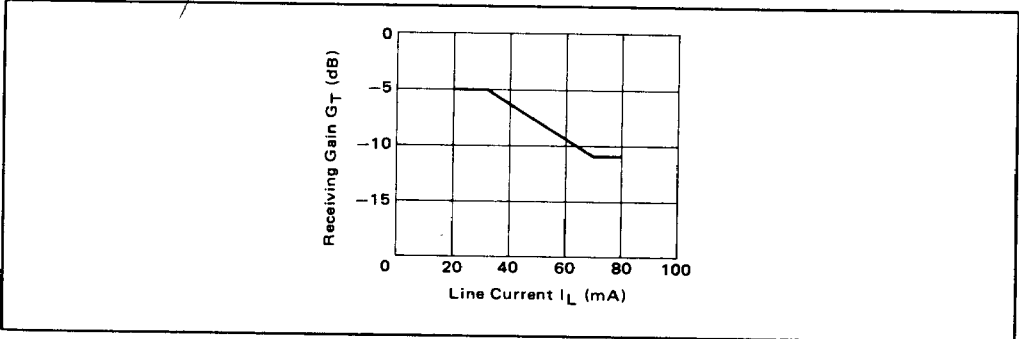

RECEIVING GAIN VS. LINE CURRENT

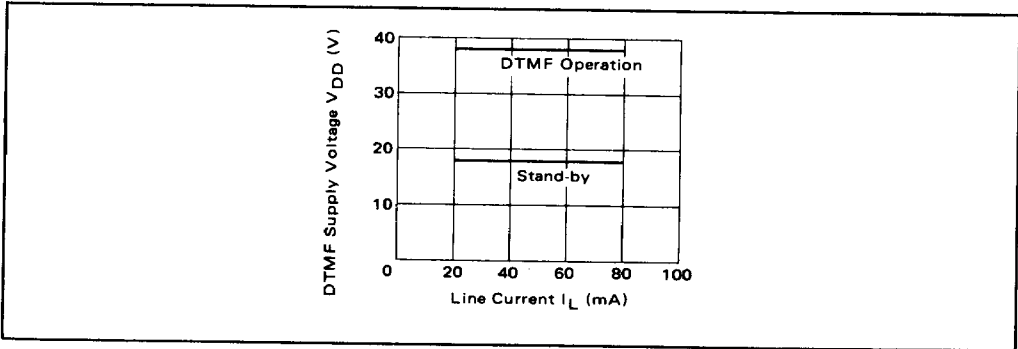

DTMF SUPPLY VOLTAGE VS. LINE CURRENT

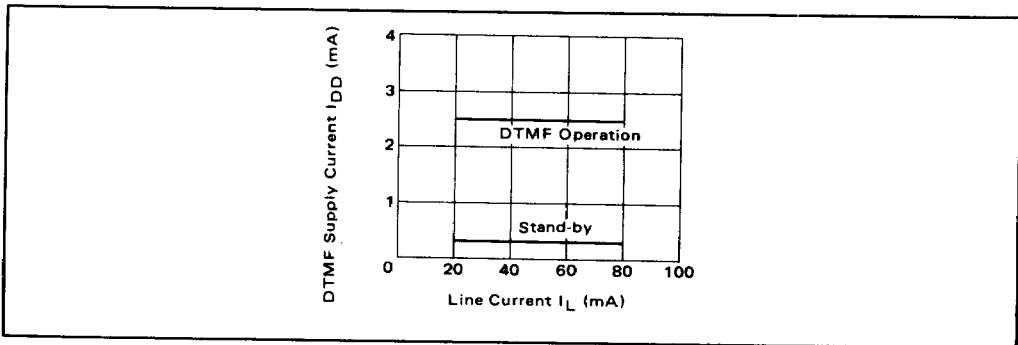

DTMF SUPPLY CURRENT VS. LINE CURRENT



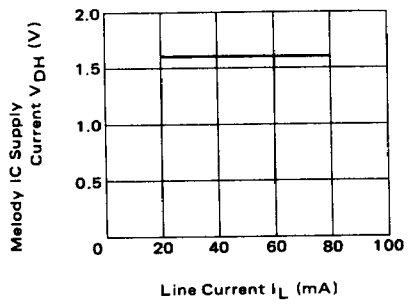

MELODY IC SUPPLY VOLTAGE VS. LINE CURRENT

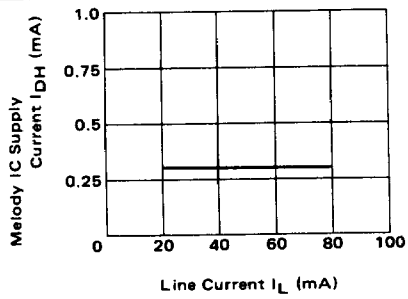

MELODY IC SUPPLY CURRENT VS. LINE CURRENT

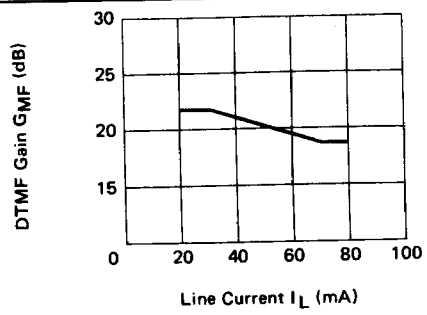

DTMF GAIN VS. LINE CURRENT

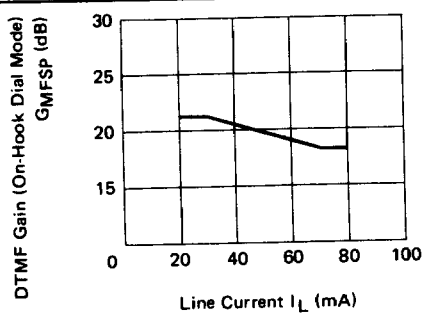

DTMF GAIN (ON-HOOK DIAL MODE) VS. LINE CURRENT



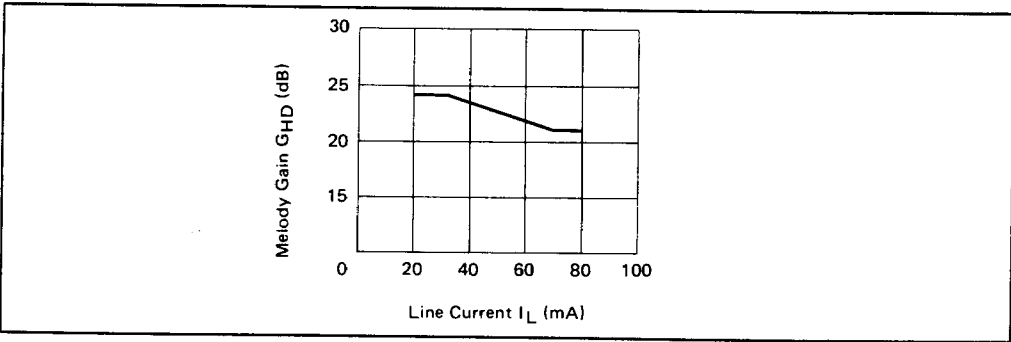

MELODY GAIN VS. LINE CURRENT

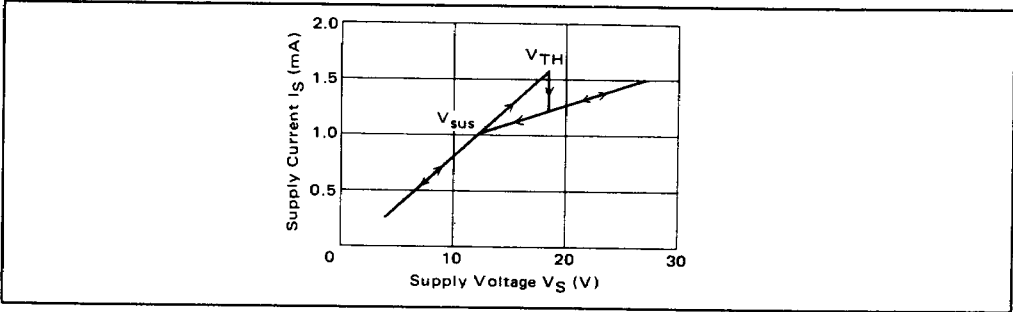

TONE RINGER SUPPLY VOLTAGE VS. SUPPLY CURRENT

