

Function generator

NE/SE566

DESCRIPTION

The NE/SE566 Function Generator is a voltage-controlled oscillator of exceptional linearity with buffered square wave and triangle wave outputs. The frequency of oscillation is determined by an external resistor and capacitor and the voltage applied to the control terminal. The oscillator can be programmed over a ten-to-one frequency range by proper selection of an external resistance and modulated over a ten-to-one range by the control voltage, with exceptional linearity.

FEATURES

- Wide range of operating voltage (up to 24V; single or dual)
- High linearity of modulation
- Highly stable center frequency (200ppm/°C typical)
- Highly linear triangle wave output
- Frequency programming by means of a resistor or capacitor, voltage or current
- Frequency adjustable over 10-to-1 range with same capacitor

PIN CONFIGURATIONS

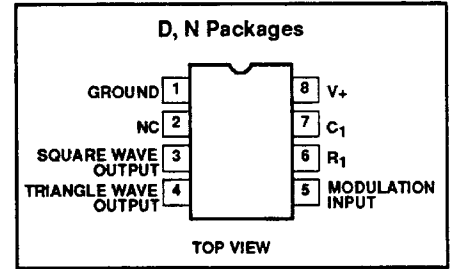

APPLICATIONS

- Tone generators
- Frequency shift keying
- FM modulators
- Clock generators
- Signal generators
- Function generators

ORDERING INFORMATION

DESCRIPTION	TEMPERATURE RANGE	ORDER CODE
8-Pin Plastic SO	0 to +70°C	NE566D
14-Pin Cerdip	0 to +70°C	NE566F
8-Pin Plastic DIP	0 to +70°C	NE566N
8-Pin Plastic DIP	-55°C to +125°C	SE566N

BLOCK DIAGRAM

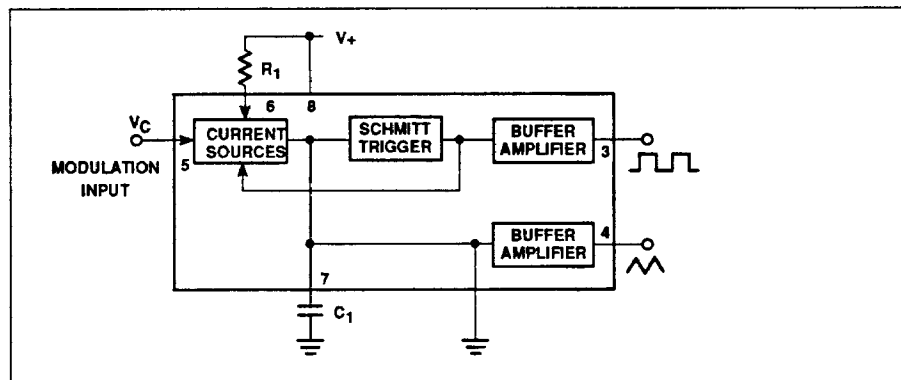

Function generator

NE/SE566

EQUIVALENT SCHEMATIC

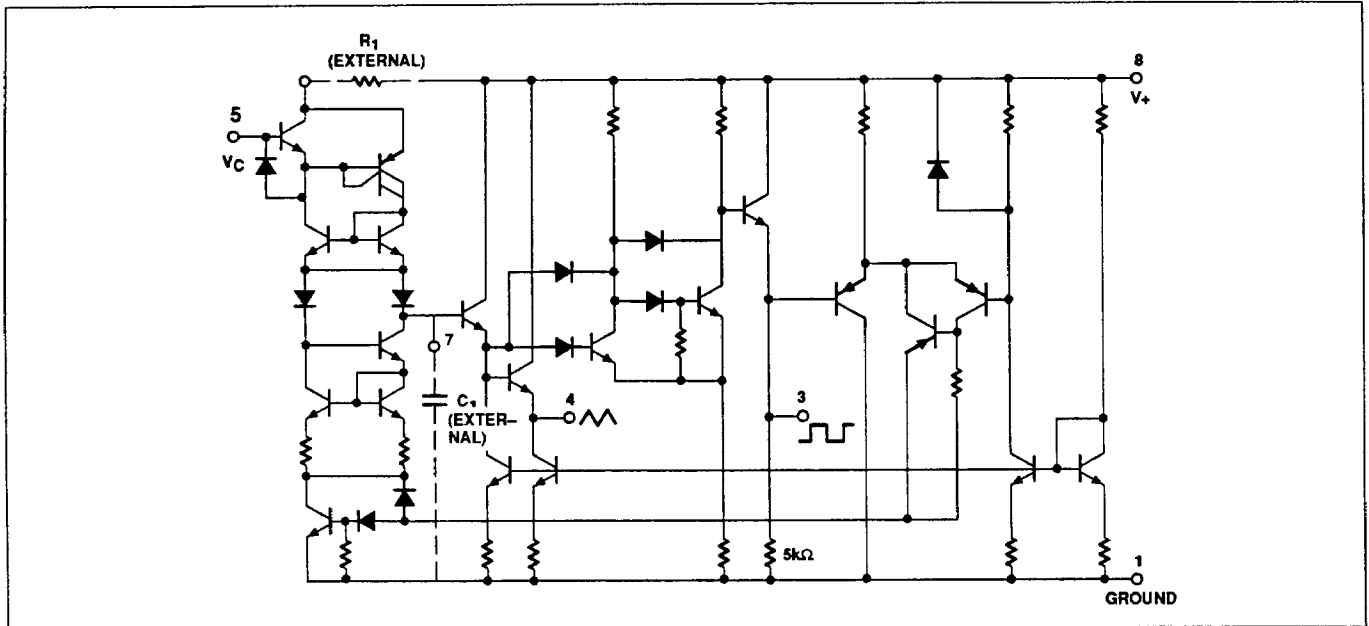

ABSOLUTE MAXIMUM RATINGS

SYMBOL	PARAMETER	RATING	UNIT
V+	Maximum operating voltage	26	V
V _{IN}	Input voltage	3	V _{P-P}
T _{STG}	Storage temperature range	-65 to +150	°C
T _A	Operating ambient temperature range		
	NE566	0 to +70	°C
	SE566	-55 to +125	°C
P _D	Power dissipation	300	mW

Function generator

NE/SE566

DC ELECTRICAL CHARACTERISTICS

 $T_A=25^{\circ}\text{C}$, $V_{CC}=\pm 6\text{V}$, unless otherwise specified.

SYMBOL	PARAMETER	SE566			NE566			UNIT
		Min	Typ	Max	Min	Typ	Max	
General								
T_A	Operating ambient temperature range	-55		125	0		70	$^{\circ}\text{C}$
V_{CC}	Operating supply voltage	± 6		± 12	± 6		± 12	V
I_{CC}	Operating supply current		7	12.5		7	12.5	mA
VCO¹								
f_{MAX}	Maximum operating frequency		1			1		MHz
	Frequency drift with temperature		500			600		ppm/ $^{\circ}\text{C}$
	Frequency drift with supply voltage		0.1	1		0.2	2	%/V
	Control terminal input impedance ²		1			1		$\text{M}\Omega$
	FM distortion ($\pm 10\%$ deviation)		0.2	0.75		0.4	1.5	%
	Maximum sweep rate		1			1		MHz
	Sweep range		10:1			10:1		
Output								
	Triangle wave output							
	impedance		50			50		Ω
	voltage	1.9	2.4		1.9	2.4		V_{P-P}
	linearity		0.2			0.5		%
	Square wave input							
	impedance		50			50		Ω
	voltage	5	5.4		5	5.4		V_{P-P}
	duty Cycle	45	50	55	40	50	60	%
t_R	Rise time		20			20		ns
t_F	Fall Time		50			50		ns

NOTES:

- The external resistance for frequency adjustment (R_1) must have a value between $2\text{k}\Omega$ and $20\text{k}\Omega$.
- The bias voltage (V_C) applied to the control terminal (Pin 5) should be in the range $V_+ \leq V_C \leq V_+$.

Function generator

NE/SE566

TYPICAL PERFORMANCE CHARACTERISTICS

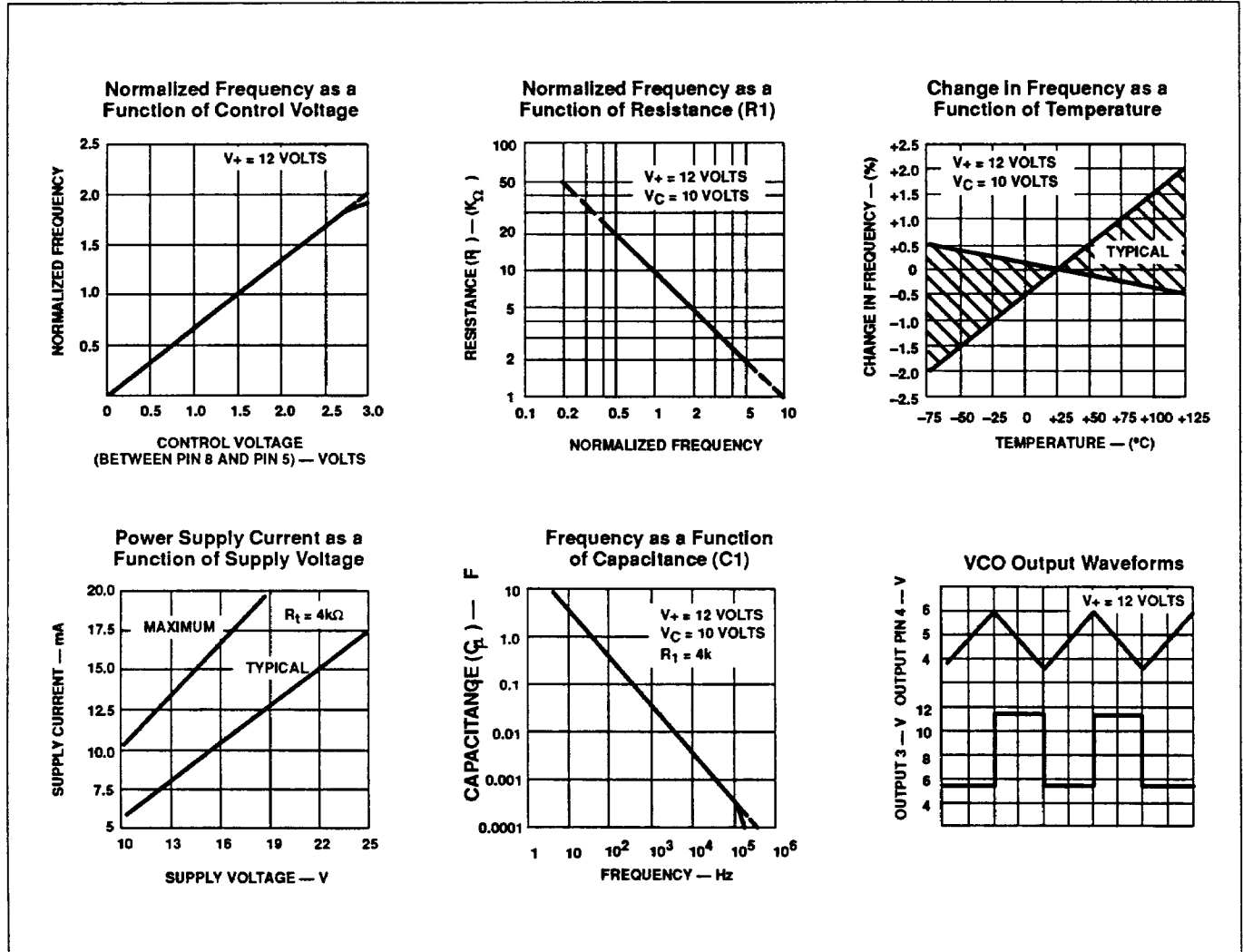

OPERATING INSTRUCTIONS

The NE/SE566 Function Generator is a general purpose voltage-controlled oscillator designed for highly linear frequency modulation. The circuit provides simultaneous square wave and triangle wave outputs at frequencies up to 1MHz. A typical connection diagram is shown in Figure 1. The control terminal (Pin 5) must be biased externally with a voltage (V_C) in the range

$$V_+ \leq V_C \leq V_+$$

where V_{CC} is the total supply voltage. In Figure 1, the control voltage is set by the voltage divider formed with R_2 and R_3 . The modulating signal is then AC coupled with the capacitor C_2 . The modulating signal can be direct coupled as well, if the appropriate DC bias voltage is applied to the control terminal. The frequency is given approximately by

$$f_0 = \frac{2 [(V_+) - (V_C)]}{R_1 C_1 V_+}$$

and R_1 should be in the range $2k\Omega < R_1 < 20k\Omega$.

A small capacitor (typically $0.001\mu F$) should be connected between Pins 5 and 6 to eliminate possible oscillation in the control current source.

If the VCO is to be used to drive standard logic circuitry, it may be desirable to use a dual supply as shown in Figure 2. In this case the square wave output has the proper DC levels for logic circuitry. RTL can be driven directly from Pin 3. For DTL or TTL gates, which require a current sink of more than 1mA, it is usually necessary to connect a $5k\Omega$ resistor between Pin 3 and negative supply.

This increases the current sinking capability to 2mA. The third type of interface shown uses a saturated transistor between the 566 and the logic circuitry. This scheme is used primarily for TTL circuitry which requires a fast fall time (<50ns) and a large current sinking capability.

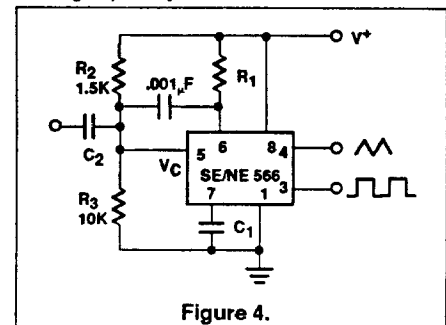

Figure 4.

Function generator

NE/SE566

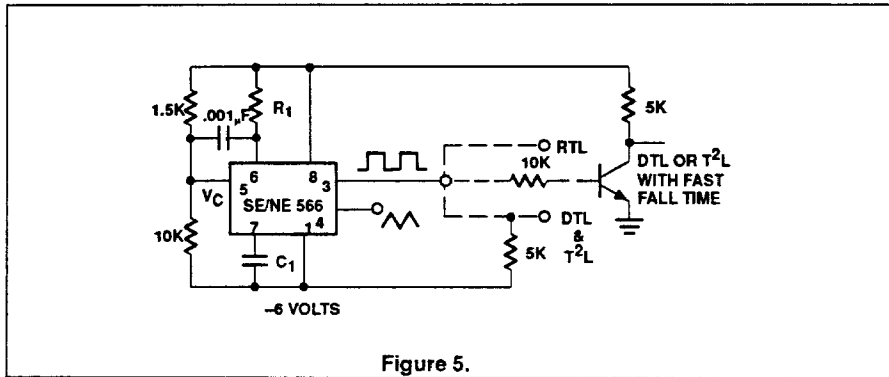

Figure 5.