

**TLS2111, TLS21R11**  
**THIN-FILM OR MIG 2- OR 4-CHANNEL**  
**LOW-NOISE READ/WRITE PREAMPLIFIERS**  
D3879, AUGUST 1991

- **Differential Input Capacitance**  
25 pF Max
- **Low Equivalent Input Noise Voltage**  
0.65 nV/ $\sqrt{\text{Hz}}$  Max
- **Read Mode Gain . . . 250 V/V Typ**
- **Wide Current Range . . . 10 mA to 35 mA**
- **Single-Supply Operation . . . 5 V**
- **Low Power Dissipation:**  
Read Mode . . . 125 mW Typ  
Idle Mode . . . 8.2 mW Typ
- **Recording Head Short-to-Ground Protection**
- **Designed for Use With Two-Terminal Thin-Film or MIG Heads With  $L_h \leq 15 \mu\text{H}$**

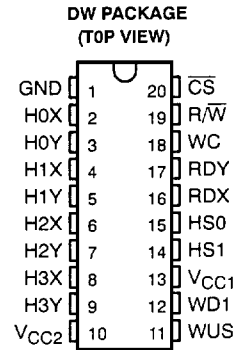

**description**

The TLS2111 and TLS21R11 are bipolar monolithic preamplifiers designed for use with two-terminal thin-film or MIG recording heads. The devices provide data protection circuitry for two or four channels with low-noise read paths and write-current controls. The write current generator can be disabled during power sequencing to provide the necessary power supply fault protection. Low input capacitance and low input noise are achieved by using Texas Instruments *IMPACT-X*™ process. The TLS21R11 is identical to the TLS2111 with the exception that it has four 700-Ω damping resistors. These are connected between the H\_X and the H\_Y terminals of the four I/O pairs.

**PRODUCT PREVIEW**

IMPACT-X is a trademark of Texas Instruments Incorporated.

PRODUCT PREVIEW Information concerns products in the formative or design phase of development. Characteristic data and other specifications are design goals. Texas Instruments reserves the right to change or discontinue these products without notice.



POST OFFICE BOX 655303 • DALLAS, TEXAS 75265

Copyright © 1991, Texas Instruments Incorporated

**TLS2111, TLS21R11**  
**THIN FILM OR MIG 2- OR 4-CHANNEL**  
**LOW-NOISE READ/WRITE PREAMPLIFIERS**

functional block diagram

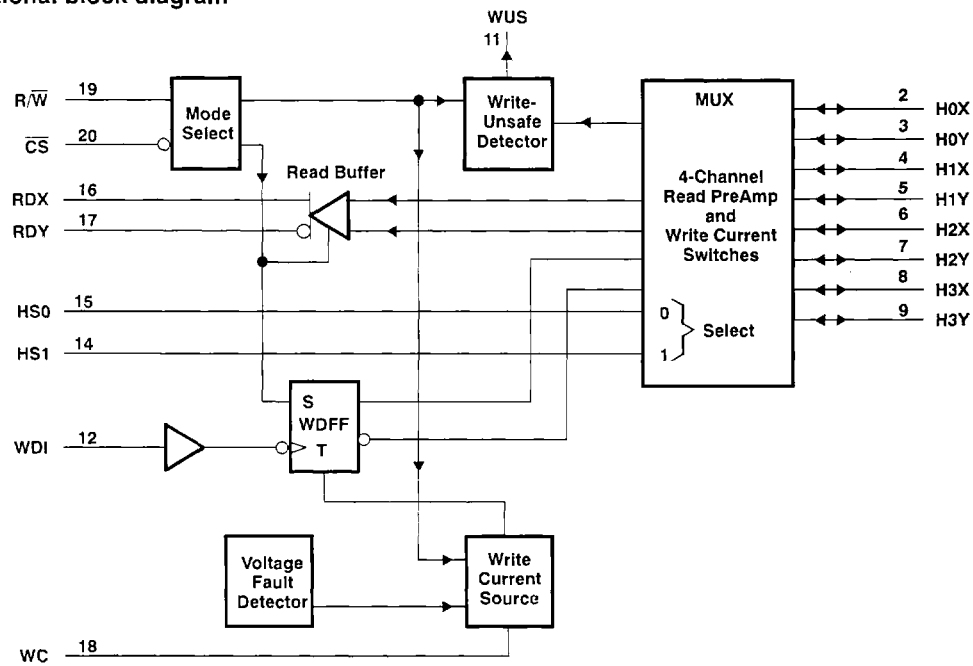

PRODUCT PREVIEW

Terminal Functions

NAME	PIN NO.	I/O	FUNCTION
CS	20	I	Chip Select: a high inhibits the chip
GND	1	-	Ground
H0X - H3X H0Y - H3Y	2 - 9	I/O	X, Y Head connections
HS0 - HS1	15, 14	I	Head Select: selects one of four heads
RDX, RDY	16, 17	O <sup>†</sup>	X, Y Read Data: differential read data output
R/W	19	I	Read/Write: a high selects the read mode
VCC1	13	-	5-V logic circuit supply voltage
VCC2	10	-	5-V write current supply voltage
WC	18	I	Write Current: used to set the magnitude of the write current
WDI	12	I	Write Data In: changes the direction of the current in the recording head
WUS	11	O <sup>†</sup>	Write Unsafe: a high indicates an unsafe writing condition

<sup>†</sup> When more than one device is used, these signals can be wire ORed.



POST OFFICE BOX 655303 • DALLAS, TEXAS 75265

**TLS2111, TLS21R11**  
**THIN-FILM OR MIG 2- OR 4-CHANNEL**  
**LOW-NOISE READ/WRITE PREAMPLIFIERS**

**absolute maximum ratings over operating free-air temperature range (unless otherwise noted)**

Supply voltage range, $V_{CC1}$ and $V_{CC2}$ (see Note 1)	-0.3 V to 7 V
Input voltage range, $V_I$ (digital)	-0.3 V to $V_{CC1} + 0.3$ V
Head port voltage range	-0.3 V to $V_{CC2} + 0.3$ V
Write current	80 mA
Output current, $I_O$ : RDX, RDY	-10 mA
WUS	12 mA
Continuous total dissipation	See Dissipation Rating Table
Operating free-air temperature range	0°C to 70°C
Storage temperature range	-65°C to 150°C
Lead temperature 1,6 mm (1/16 inch) from case for 10 seconds	260°C

NOTE 1: All voltage values are with respect to the GND terminal.

**DISSIPATION RATING TABLE**

PACKAGE	T <sub>A</sub> ≤ 25°C POWER RATING	DERATING FACTOR ABOVE T <sub>A</sub> = 25°C	T <sub>A</sub> = 70°C POWER RATING
DW	1025 mW	8.2 mW/°C	656 mW

**recommended operating conditions**

	MIN	NOM	MAX	UNIT
Supply voltage, $V_{CC1}$ and $V_{CC2}$	4.75	5	5.25	V
Low-level input voltage, $V_{IL}$	-0.3		0.8	V
High-level input voltage, $V_{IH}$	2			V
Operating free-air temperature, T <sub>A</sub>	0		70	°C
Operating junction temperature, T <sub>J</sub>	25		110	°C

**electrical characteristics over full ranges of recommended operating conditions**

PARAMETER	TEST CONDITIONS	MIN	TYP†	MAX	UNIT
V <sub>OL</sub> Low-level output voltage, WUS	I <sub>OL</sub> = 2 mA Max			0.5	V
I <sub>IH</sub> High-level input current	V <sub>IH</sub> = 2 V			100	μA
I <sub>IL</sub> Low-level input current	V <sub>IL</sub> = 0.8 V			-0.4	mA
I <sub>O</sub> Output current, IMF	C <sub>S</sub> = 0.8 V	0.73	0.85	1.23	mA
	C <sub>S</sub> = 2 V		0.01	0.02	
I <sub>CC1</sub> Supply current	Read mode	14	19	24	mA
	Write mode	11	16	21	
	Idle mode	1.3	1.6	2	
I <sub>CC2</sub> Supply current	Read mode	4.6	5.9	6.8	mA
	Write mode	5.4+I <sub>W</sub>	6.6+I <sub>W</sub>	8.4+I <sub>W</sub>	
	Idle mode	0.02	0.03	0.04	
P <sub>D</sub> Power dissipation	Read mode		125	154	mW
	Write mode		113+4I <sub>W</sub>	150+4I <sub>W</sub>	
	Idle mode		8.2	10.7	

**PRODUCT PREVIEW**



**TLS2111, TLS21R11**  
**THIN FILM OR MIG 2- OR 4-CHANNEL**  
**LOW-NOISE READ/WRITE PREAMPLIFIERS**

**read characteristics**

PARAMETER	TEST CONDITIONS	MIN	TYP†	MAX	UNIT
V <sub>OO</sub> Output offset voltage				±300	mV
A <sub>VD</sub> Differential voltage amplification	V <sub>I</sub> (PP) = 1 mV at 1 MHz, R <sub>L</sub> (RDX) and R <sub>L</sub> (RDY) = 1 kΩ	235	250	270	V/V
Dynamic range‡	V <sub>I</sub> = V <sub>DC</sub> + 0.5 mV PP, f = 5 MHz	±3			mV PP
I <sub>IB</sub> Input bias current			51	170	μA
I <sub>O</sub> Output current	AC-coupled load, RDX to RDY	1.4			mA
V <sub>n</sub> Input noise voltage	BW = 15 MHz, L <sub>h</sub> = 0, R <sub>h</sub> = 0		0.54	0.65	nV/√Hz
V <sub>OC</sub> Common-mode output voltage	RDX to RDY	2	2.5	3.5	V
BW Bandwidth	V <sub>I</sub> (PP) = 1 mV at 1 MHz,  Z <sub>S</sub>   < 5 Ω			-1 dB	20
				-3 dB	35
CMRR Common-mode rejection ratio	V <sub>I</sub> = 0 ± 100 mV PP at 5 MHz	45			dB
a <sub>x</sub> Crosstalk attenuation	Unselected channels driven with 100 mV PP at 5 MHz, V <sub>I</sub> = 0 V DC + 100 mV PP	45			dB
k <sub>SVR</sub> Power supply rejection ratio	100 mV PP at 5 MHz on V <sub>CC</sub>	40			
C <sub>id</sub> Differential input capacitance			18	25	pF
r <sub>id</sub> Differential input resistance	f = 5 MHz	0.835			kΩ
r <sub>o</sub> Output resistance (single-ended)				40	Ω

‡ This is the dc input voltage where gain falls to 90% of its 0-V dc value.

**write characteristics, I<sub>W</sub> = 20 mA, L<sub>h</sub> = 1 μH, R<sub>h</sub> = 30 Ω, f<sub>data</sub> = 5 MHz, C<sub>L</sub>(RDX, RDY) < 20 pF, R<sub>L</sub>(RDX, RDY) = 1 kΩ**

PARAMETER	TEST CONDITIONS	MIN	TYP†	MAX	UNIT
V <sub>WC</sub> Voltage at WC		1.15	1.25	1.35	V
Differential head voltage swing		3.4			V pk
I <sub>X</sub> - I <sub>Y</sub> Unselected head current				1	mA pk
C <sub>od</sub> Differential output capacitance				25	pF
r <sub>od</sub> Differential output resistance		4			kΩ
f <sub>T</sub> WDI transition frequency	WUS = low	1			MHz
I <sub>W</sub> Write current		10		35	mA

† All typical values are at V<sub>CC1</sub> = V<sub>CC2</sub> = 5 V and T<sub>A</sub> = 25°C.

**switching characteristics over full ranges of recommended operating conditions, I<sub>W</sub> = 20 mA, L<sub>h</sub> = 1 μH, R<sub>h</sub> = 30 Ω, f<sub>data</sub> = 5 MHz**

PARAMETER	TEST CONDITIONS	MIN	TYP†	MAX	UNIT
t <sub>RWR</sub> R/W to read	To 90% of 100 mV, f = 10 MHz, read signal envelope		0.5	1	μs
t <sub>RWW</sub> R/W to write	To 90% of write current		0.1	1	μs
t <sub>CSW</sub> CS to select write			0.4	1	μs
t <sub>CSR</sub> CS to unselect read	To 90% of 100 mV, f = 10 MHz, read signal envelope		0.4	1	μs
t <sub>HSH</sub> HS0, HS1 to any head	To 90% of 100 mV, f = 10 MHz, read signal envelope		0.2	1	μs
t <sub>d1</sub> Delay time, WDI low to WUS high		0.6	2	3.6	μs
t <sub>d2</sub> Delay time, WDI low to WUS low			0.2	1	μs
t <sub>d3</sub> WDI to (I <sub>X</sub> - I <sub>Y</sub> )	L <sub>h</sub> = 0, R <sub>h</sub> = 0			32	ns
t <sub>SYM</sub> Head current pulse asymmetry	WDI has 50% duty cycle, L <sub>h</sub> = 0, R <sub>h</sub> = 0		1		ns
t <sub>r</sub> Head current pulse rise time	L <sub>h</sub> = 0, R <sub>h</sub> = 0		6	12	ns
t <sub>f</sub> Head current pulse fall time	L <sub>h</sub> = 0, R <sub>h</sub> = 0		7	12	ns

† All typical values are at V<sub>CC1</sub> = V<sub>CC2</sub> = 5 V and T<sub>A</sub> = 25°C.

**PRODUCT PREVIEW**



PARAMETER MEASUREMENT INFORMATION

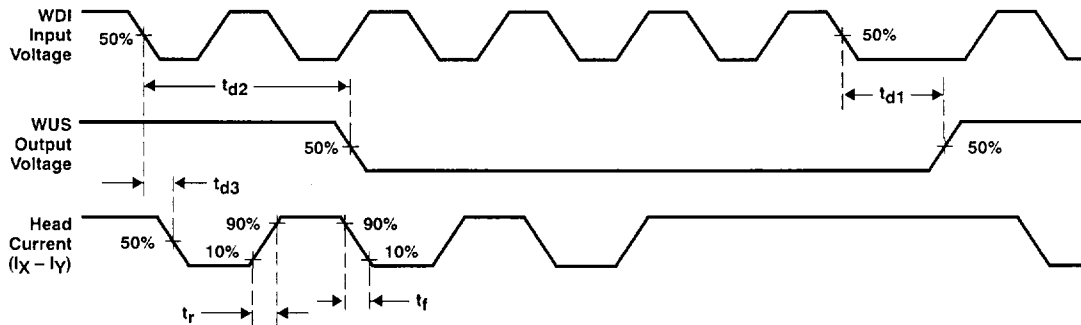

Figure 1. Write Mode Waveform

Table 1. Mode Select

$\overline{CS}$	$R/\overline{W}$	MODE
L	L	Write
L	H	Read
H	L	Idle
H	H	Idle

Table 2. Head Select

HS1	HS0	HEAD
L	L	0
L	H	1
H	L	2
H	H	3

APPLICATION INFORMATION

circuit operation

The TLS2111 and TLS21R11 function as read amplifiers or write drivers for the selected head and have the capability of addressing up to four two-terminal MIG or thin-film heads. Tables 1 and 2 describe the mode and head select conditions. To protect against an accidental write condition occurring, inputs  $R/\overline{W}$  and  $\overline{CS}$  are connected to internal pullup resistors. In any mode, internal clamp circuits will protect the device from a head short-to-ground. Internal pulldown resistors are connected to HS0 and HS1 head select pins.

read mode

In the read mode, the TLS2111 and TLS21R11 operate as low-noise differential amplifiers that deactivate the write current generator. The read-data outputs RDX and RDY are emitter-follower driven and should be externally ac-coupled to the load. The read amplifier is deactivated resulting in RDX and RDY outputs moving into the high-impedance state in either the write or idle mode. RDX and RDY can then be ORed when switching from write to read modes resulting in lower voltage drifts. In the idle mode as well as in the read mode, the write current generator is deactivated.

PRODUCT PREVIEW

# TLS2111, TLS21R11 THIN FILM OR MIG 2- OR 4-CHANNEL LOW-NOISE READ/WRITE PREAMPLIFIERS

---

## write mode

The TLS2111 and TLS21R11 act as current switches in the write mode and activate the write-unsafe detector when  $\overline{CS}$  and  $R/\overline{W}$  have both gone low. On the falling edge of the write data input WDI, the write current is toggled between the X and Y directions of the recording head; the value of the write current is given by:

$$I_W = \frac{V_{wc}}{R_{wc}} \quad \text{where: } \begin{array}{l} V_{wc} = \text{write current voltage and} \\ R_{wc} = \text{external resistor connects WC pin to GND pin.} \end{array}$$

$$\text{The head current } I_x, I_y = \frac{I_W}{\left(1 + \frac{R_h}{R_d}\right)} \quad \text{where: } \begin{array}{l} R_h = \text{head resistance plus external resistance} \\ R_d = \text{damping resistance} \end{array}$$

## idle mode

The idle mode is selected by taking  $\overline{CS}$  high (see Table 1), and this allows the circuits to be multiplexed. The internal write-current generator and write-unsafe detector are deactivated while RD+ and RD- outputs switch into the high-impedance state. The read outputs are ORed together and the write-current programming resistors are common to all devices to promote multidevice installation. The TLS2111 and TLS21R11 are specially designed for low-power dissipation in the idle mode.

## fault detection

A voltage fault detection circuit is provided to disable the write-current generator during power start-up or voltage fault in any mode. Any of the following four conditions causes WUS to go high, indicating a fault:

- Write current is zero
- Frequency on WDI is too low
- Unit is in the read mode
- Chip is disabled.

One negative transition on WDI is required to clear WUS after the fault condition is removed.

PRODUCT PREVIEW

