

# Type N Panel Mount - 4 Hole Flange

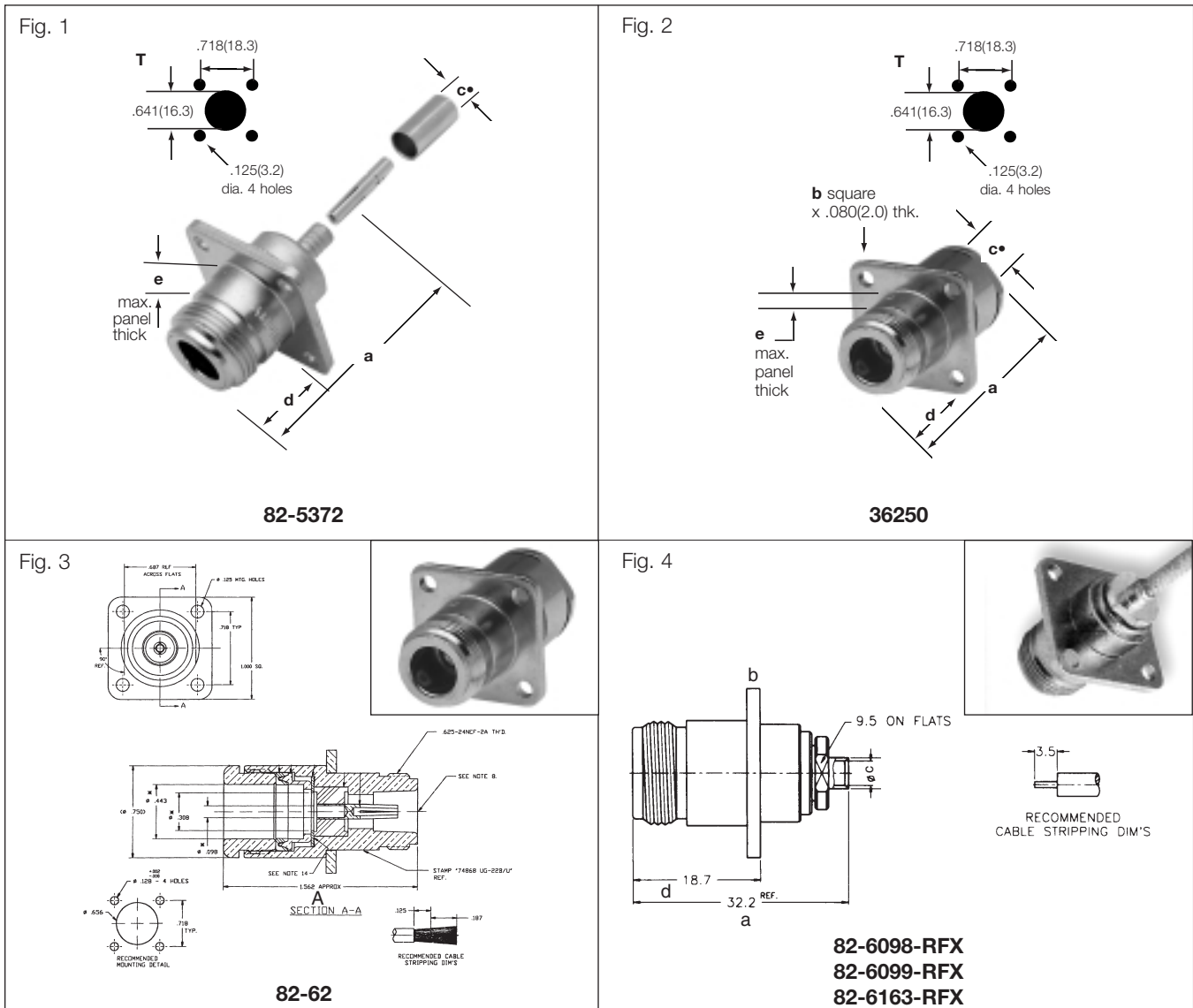

## N PANEL JACKS

Cable RG-/U	Conn. Type	Cable Attachment		Dimensions, inches (millimeters)					Notes			Mtg Hole	Military Number	Amphenol Number	Fig
		Outer	Inner	a	b	c •	d	e	CAI	Plt.	Ins.				
55, 141, 142	Panel	Crimp	Crimp	1.56(39.7)	1.00(25.4)	.220(5.6)	.576(14.6)	.125(3.2)▼	C11	P15	D1	T	—	82-5372	2
55, 58, 141,	Panel	Clamp	Solder	1.50(38.1)	1.00(25.4)	.224(5.7)	.656(16.7)	.219(5.6)▼	C8	P1	D1	T	UG-1095A/U	36250	1
8, 9, 87A, 144,165,213, 214,216,225	Panel	Clamp	Solder	1.56(39.7)	1.00(25.4)	.440(11.2)	—	—	C8	P1	D1	—	UG-23B/U	82-62	3
405 (.085) S/R	Panel	Solder	Solder	1.26(32.2)	1.00(25.4)	.086(2.2)	.736(18.7)	—	C9	P7	D1	T	—	82-6098-RFX	4
402 (.141) S/R	Panel	Solder	Solder	1.26(32.2)	1.00(25.4)	.141(3.6)	.736(18.7)	—	C9	P7	D1	T	—	82-6099-RFX	4
401 (.250) S/R	Panel	Solder	Solder	1.26(32.2)	1.00(25.4)	.250(6.35)	.736(18.7)	—	C9	P7	D1	T	—	82-6163-RFX	4