

PART NUMBER	RUBBER GLAND
10135746-101LF	Ø6
10135746-102LF	Ø7 & Ø9
10135746-103LF	Ø8

OCTIS SFP/SFP+ PLUG KIT-STANDARD LEVER,PITCH 26MM

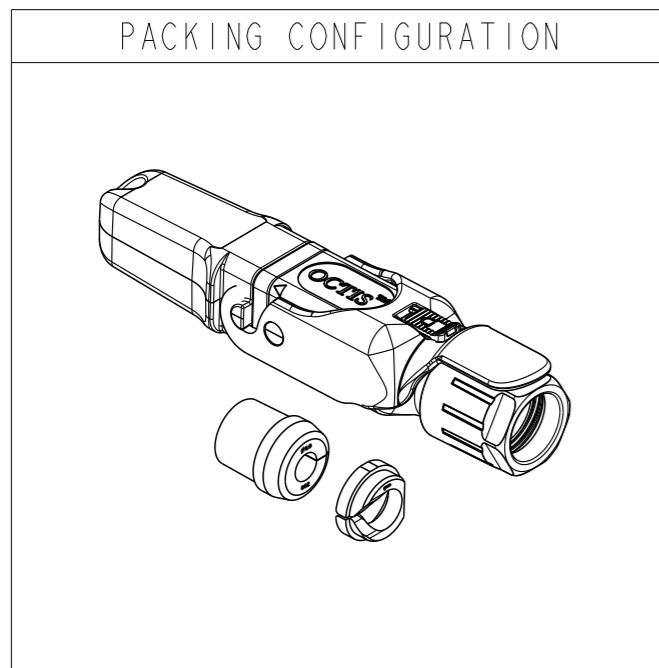
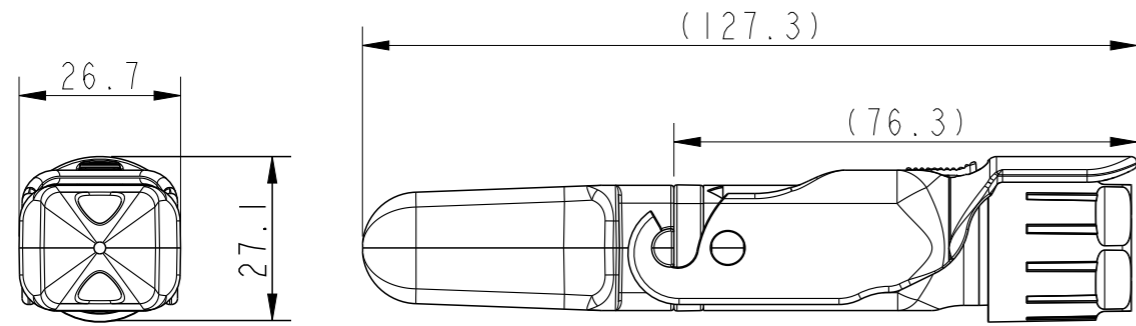
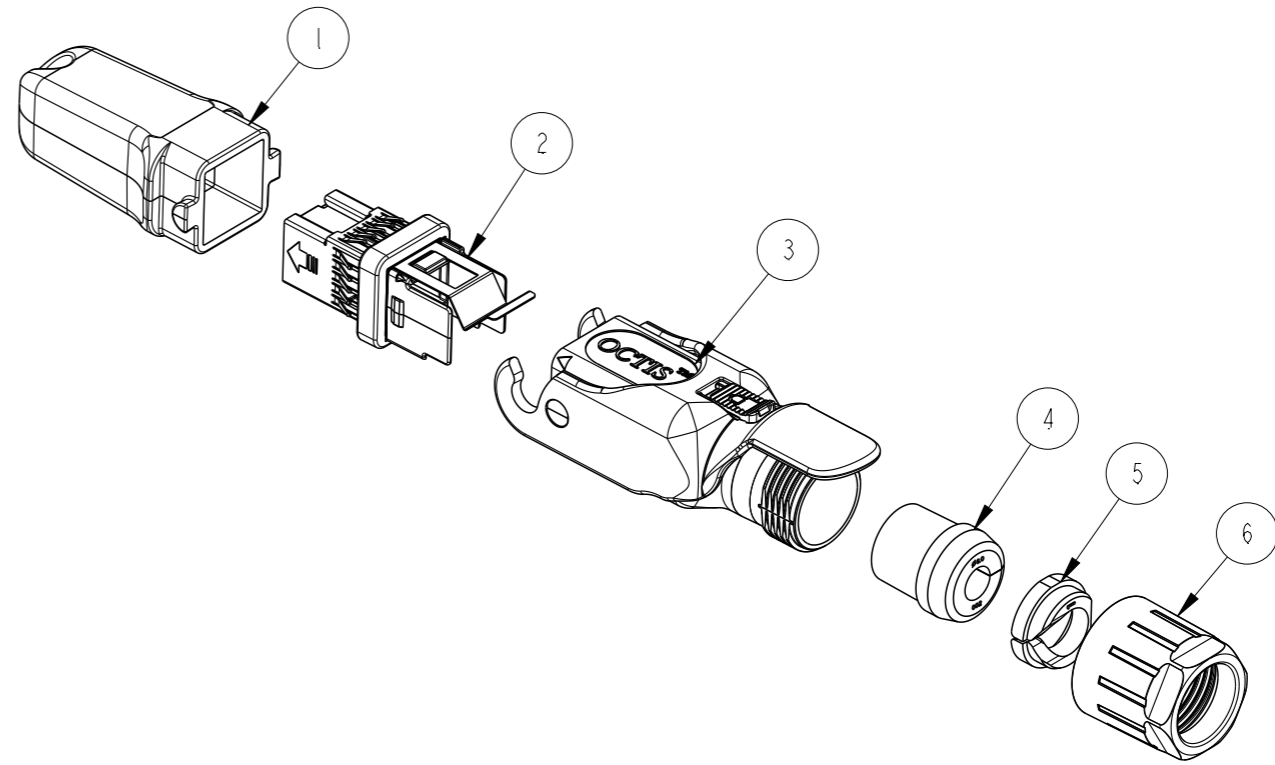

SL NO.	COMPONENT	MATERIAL	REMARKS
1	PLUG CAP	PBT GF	-
2	HOLDER SUBSET KIT	ZAMAK+ STAINLESS STEEL+ SILICONE	PASSIVATED
3	HOUSING SUBSET KIT	PBT GF+IXEF	STANDARD FITTED LEVER
4	SPLIT RUBBER GLAND	SILICONE	SEE PAGE 3
5	TIGHTENING CONE	PA	-
6	GLAND NUT	PBT GF	COLOUR: BLUE

*STANDARD RUBBER GLAND DIA OFFERED IS 6MM
OPTIONAL RUBBER GLAND DIA OF 7MM, 8MM, 9MM, 10MM AND 11.5MM AVAILABLE ON REQUEST

spec ref	dr	Varghese, Bone	2019/06/12	projection	mm	size	A3	scale	3:10
tolerance std	eng	Alosius, Stali	2021/06/02			ecn no	ELX-I-41073-1	rel level	Released
ISO 406 ISO 1101	chr	-	-						
surface	linear	0.X	±0.3		OCTIS SFP/SFP+ PLUG KIT OCTIS PITCH 26 MM	dwg no	10135746	rev	M
		0.XX	±0.13						
ISO 1302	angular	0°	±2°						

BOARD CONNECTOR WITH BULK HEAD (RECEPTACLE) DETAILS

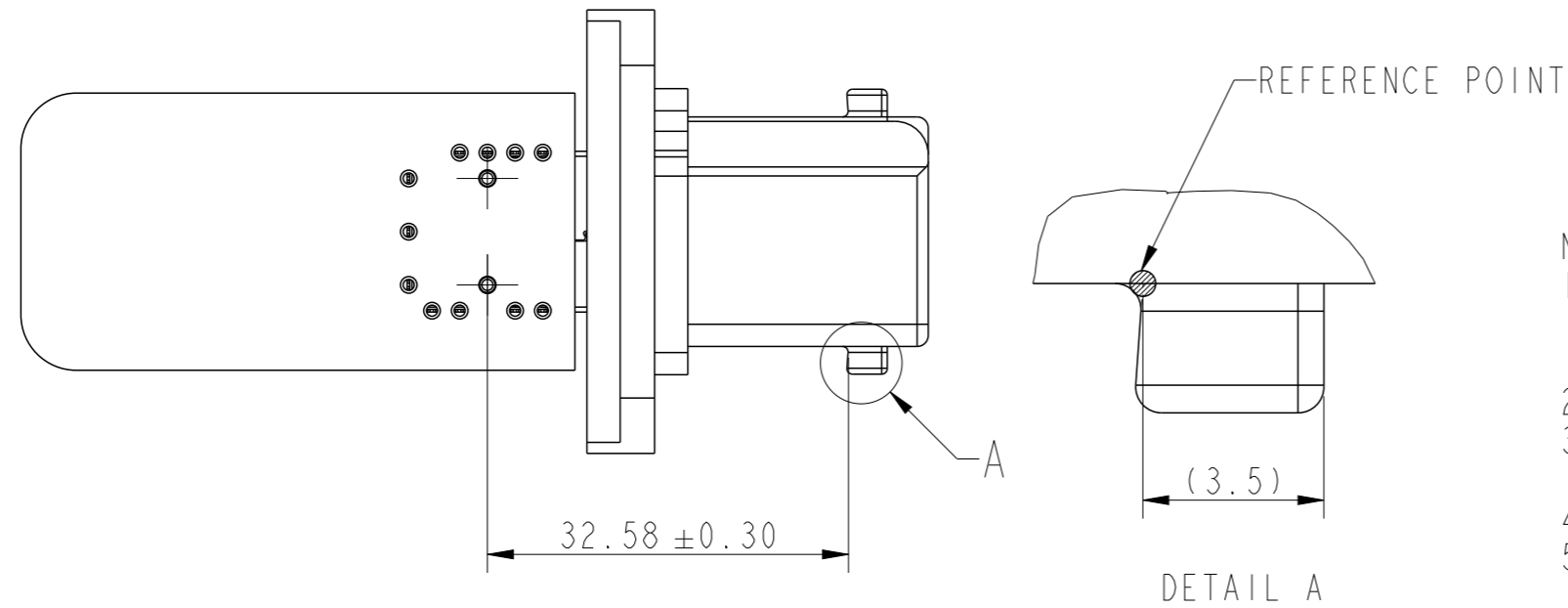
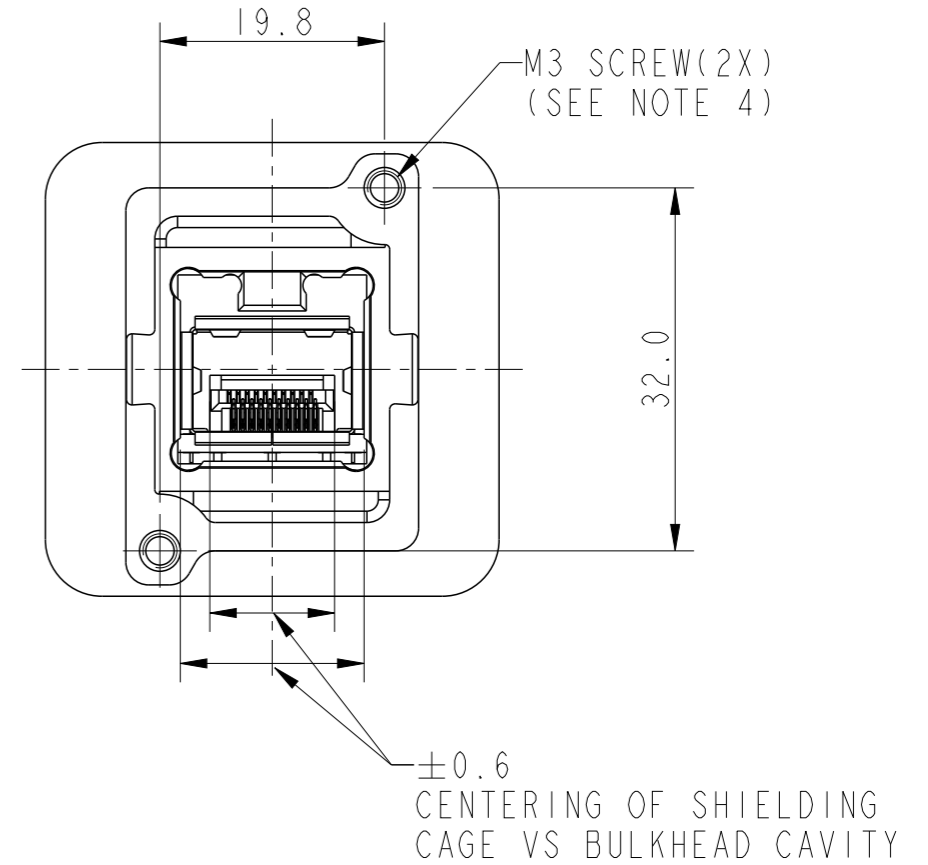
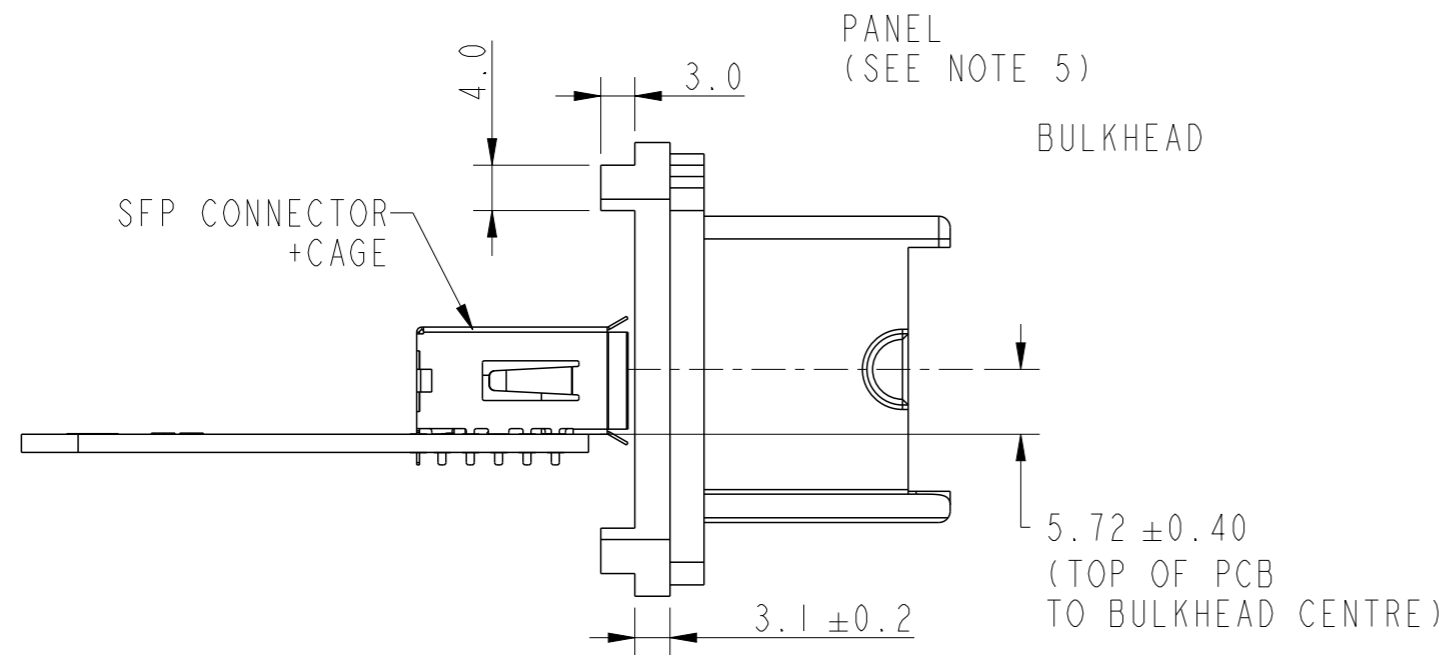

- NOTES:
- BOARD CONNECTOR SHOWN IS FOR REFERENCE PURPOSE. REFER DRAWING P-UE76-A20-X00XX FOR BOARD CONNECTOR DETAILS
 - REFER DRAWING 10133694 FOR CAGE DETAILS
 - REFER DRAWING 10138458 FOR BULK HEAD (RECEPTACLE) DETAILS
 - SCREWS TO BE USED ARE M3 X 6MM; MATERIAL-STAINLESS STEEL
 - CASTED MOUNTING PANEL SHOULD HAVE ON ITS REAR SIDE AN INTEGRAL RECTANGULAR REINFORCED RIBS OF 3MM THICKNESS AND 4MM WIDTH ALONG THE MOUNTING SCREW PLANE AT THE TOP AND BOTTOM TO ACCOMODATE THE BLIND INTERNAL SCREW THREAD

spec ref		dr	Varghese, Bone	2019/06/12	projection	mm	size	A3	scale	1:1
tolerance std		eng	Alosius, Stali	2021/06/02			ecn no	ELX-I-41073-1	rel level	Released
ISO 406 ISO 1101		chr	-	-						
surface	linear	0.X	±0.3	Amphenol FCI	OCTIS SFP/SFP+ PLUG KIT		dwg no	10135746	rev	M
		0.XX	±0.13		OCTIS PITCH 26 MM					
ISO 1302	angular	0°	±2°		cat. no.	-	Product - Customer Drw	sheet 2 of 4		

FAN-OUT DEFINITION

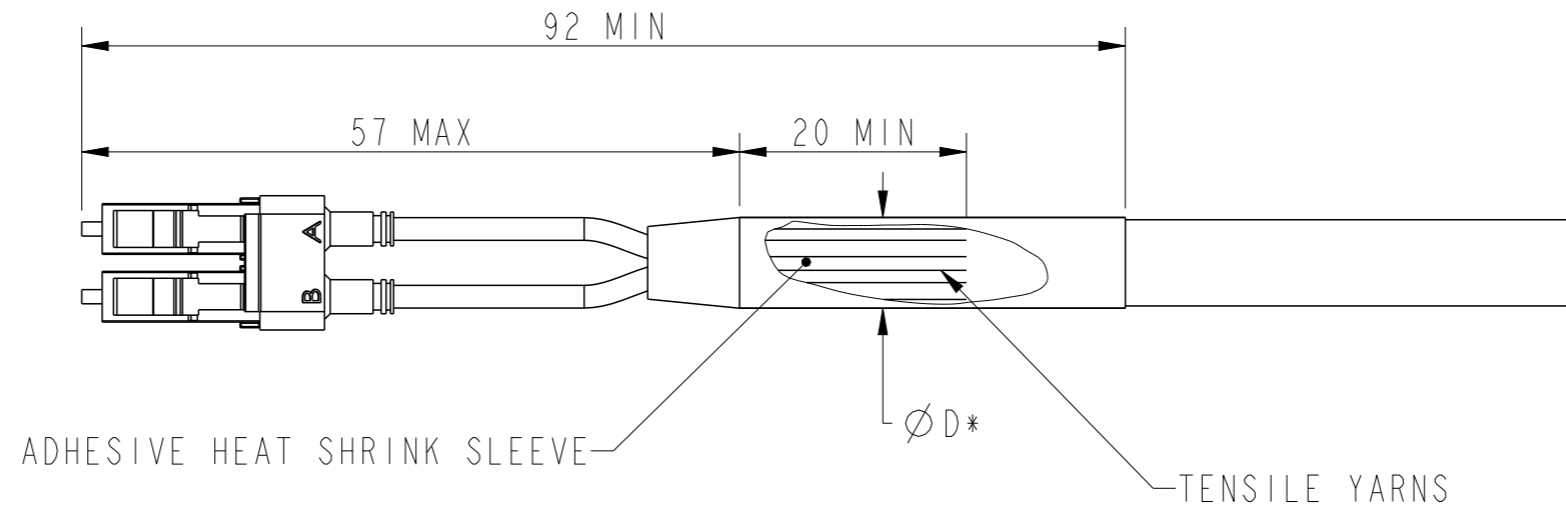

ØD*	RECOMMENDED GLAND SIZE
From 4.8 min to 5.8 Max	"6"
From 5.8 min to 6.8 Max	"7"
From 6.8 min to 7.8 Max	"8"
From 7.8 min to 8.8 Max	"9"
From 8.8 min to 9.8 Max	"10"
From 10.3 min to 11.3 Max	"11.5"

*CABLE DIAMETER UNDER THE GLAND. IF THE CABLE HAS A SLEEVE, THE DIAMETER OVER THE SLEEVE SHOULD BE CONSIDERED THE TOLERANCE OF ØD SHOULD BE TAKEN INTO ACCOUNT TO MAKE SURE IT IS ALWAYS WITHIN THE SPECIFIED RANGE

spec ref	dr	Varghese, Bone	2019/06/12	projection	mm	size	A3	scale	1:2
tolerance std	eng	Alosius, Stali	2021/06/02			ecn no	ELX-I-41073-1		
ISO 406 ISO 1101	chr	-	-				rel level	Released	
surface	appr	Kuriakose, San	2021/06/04	product family	-	rel level	Released		
ISO 1302 	linear	0.X	±0.3	Amphenol FCI OCTIS SFP/SFP+ PLUG KIT OCTIS PITCH 26 MM	cat. no.	-	Product - Customer Drw	sheet 3 of 4	rev
		0.XX	±0.13						
0.XXX	±0.05								
angular	0°	±2°							M

GENERAL CHARACTERISTICS(*)

MECHANICAL MATING ENDURANCE (CYCLES) AXIAL TENSILE LOAD (N MIN) VIBRATION RECOM. COUPLING TORQUE (N.CM) WEIGHT (G)	EIA 364-09 - GR 3108 - -	100 150 (**) - 200MIN. / 250MAX 60.00
ENVIRONMENTAL PROTECTION CLASS (MATED CONDITION) OPERATING TEMPRATURE (°C) STORAGE TEMPRATURE (°C) HUMIDITY (DAMP HEAT) (%RH) SALT SPRAY ROHS FLAMMABILITY UVB RESIST	IEC 60529 EIA-364-32 EIA-364-32 EIA-364-31 GR-950 - UL94 ASTM G154	IP67(***) -40/+85 -40/+85 80-98% RH 720H(***) COMPLIANT V0 COMPLIANT
OTHERS: EQUIPMENT INTERFACE SFP /SFP+ CABLE PACKAGING	- MSA -	FOR USE WITH OCTIS PANEL INTERFACE OR RECEPTACLE **** FOR USE WITH TRANSCEIVER COMPLYING TO THE SFP/SFP+ STANDARD FOR USE WITH STANDARD LC DUPLEX PATCHCORD, MULTIMODE OR SINGLEMODE.***** UNITARY IN PLASTIC BAG WITH ASSEMBLY NOTE.

* OCTIS INTERFACE SPECIFICATION-PRODUCT SPECIFICATION - GS-12-1413
 **DEPENDING ON CABLE CHARACTERISTICS
 ***MATED CONDITION
 ****IF THE INTERFACE IS TO BE DIE CASTED INTO THE EQUIPMENT PANEL, PLEASE CONTACT AMPHENOL FOR LICENSE CONDITIONS AND INTERFACE DEFINITION
 *****REFER TO FAN-OUT DIMENSIONAL REQUIREMENT AND RUBBER GLAND SELECTION CHART IN PAGE 3

spec ref		dr	Varghese, Bone	2019/06/12	projection 	mm ←————→	size	A3	scale	1:2	
tolerance std		eng	Alosius, Stali	2021/06/02			ecn no	ELX-I-41073-1			
ISO 406 ISO 1101		TOLERANCES UNLESS OTHERWISE SPECIFIED			chr	-	rel level	Released			
surface	linear	0.X	±0.3	Amphenol FCI	product family		OCTIS SFP/SFP+ PLUG KIT	dwg no	10135746	rev	M
		0.XX	±0.13		-						
	0.XXX	±0.05	-								
ISO 1302	angular	0°	±2°	cat. no.	-	Product - Customer Drw	sheet 4 of 4				