

GENERAL DESCRIPTION

The HI-85820 and HI-85830 from Holt Integrated Circuits are silicon gate CMOS devices for interfacing a 16-bit parallel data bus directly to the ARINC 429 serial bus. The HI-85820/HI-85830 design offers many enhancements to the industry standard HI-8282 architecture. The device provides two receivers each with label recognition, 32 by 32 FIFO, and analog line receiver. Up to 16 labels may be programmed for each receiver. The independent transmitter has a 32 X 32 FIFO and a built-in line driver. The status of all three FIFOs can be monitored using the external status pins, or by polling the HI-85820/HI-85830 status register. Other new features include a programmable option of data or parity in the 32nd bit, and the ability to unscramble the 32 bit word. Also, versions are available with different values of input resistance and output resistance to allow users to more easily add external lightning protection circuitry. The device can be used at nonstandard data rates when an option pin, $\overline{\text{NFD}}$, is invoked.

The 16-bit parallel data bus exchanges the 32-bit ARINC data word in two steps when either loading the transmitter or interrogating the receivers. The databus and all control signals are CMOS and TTL compatible.

The HI-85820/HI-85830 apply the ARINC protocol to the receivers and transmitter. Timing is based on a 1 Mega-hertz clock.

Although the line driver shares a common substrate with the receivers, the design of the physical isolation does not allow parasitic crosstalk, and thereby achieves the same isolation as common hybrid layouts.

APPLICATIONS

- Avionics data communication
- Serial to parallel conversion
- Parallel to serial conversion

FEATURES

- ARINC specification 429 compatible
- Dual receiver and transmitter interface
- Analog line driver and receivers connect directly to ARINC bus
- Programmable label recognition
- On-chip 16 label memory for each receiver
- 32 x 32 FIFOs each receiver and transmitter
- Independent data rate selection for transmitter and each receiver
- Status register
- Data scramble control
- 32nd transmit bit can be data or parity
- Self test mode
- Low power
- Industrial & extended temperature ranges

PIN CONFIGURATION (Top View)

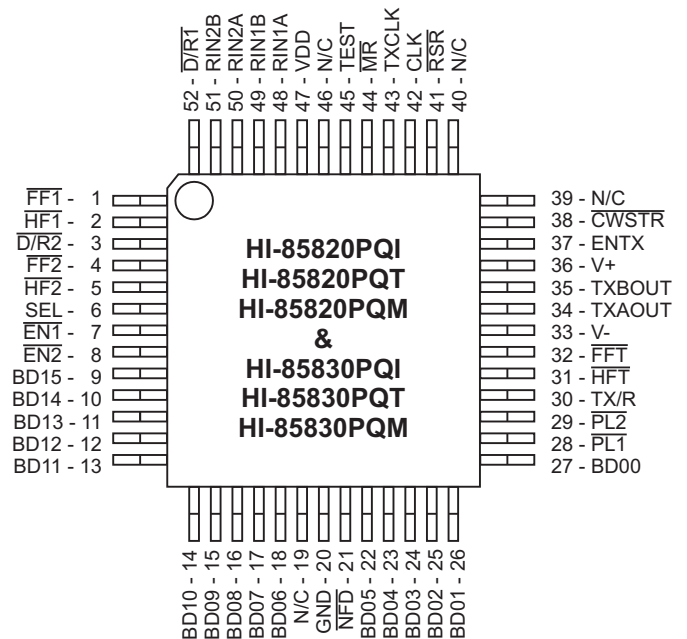

52 - Pin Plastic Quad Flat Pack (PQFP)

(See page 14 for additional pin configuration)

PIN DESCRIPTIONS

SIGNAL	FUNCTION	DESCRIPTION
VDD	POWER	+5V ±5%
RIN1A	INPUT	ARINC receiver 1 positive input
RIN1B	INPUT	ARINC receiver 1 negative input
RIN2A	INPUT	ARINC receiver 2 positive input
RIN2B	INPUT	ARINC receiver 2 negative input
$\overline{D/R1}$	OUTPUT	Receiver 1 data ready flag
$\overline{FF1}$	OUTPUT	FIFO full Receiver 1
$\overline{HF1}$	OUTPUT	FIFO Half full, Receiver 1
$\overline{D/R2}$	OUTPUT	Receiver 2 data ready flag
$\overline{FF2}$	OUTPUT	FIFO full Receiver 2
$\overline{HF2}$	OUTPUT	FIFO Half full, Receiver 2
SEL	INPUT	Receiver data byte selection (0 = BYTE 1) (1 = BYTE 2)
$\overline{EN1}$	INPUT	Data Bus control, enables receiver 1 data to outputs
$\overline{EN2}$	INPUT	Data Bus control, enables receiver 2 data to outputs if $\overline{EN1}$ is high
BD15	I/O	Data Bus
BD14	I/O	Data Bus
BD13	I/O	Data Bus
BD12	I/O	Data Bus
BD11	I/O	Data Bus
BD10	I/O	Data Bus
BD09	I/O	Data Bus
BD08	I/O	Data Bus
BD07	I/O	Data Bus
BD06	I/O	Data Bus
GND	POWER	0 V
BD05	I/O	Data Bus
BD04	I/O	Data Bus
BD03	I/O	Data Bus
BD02	I/O	Data Bus
BD01	I/O	Data Bus
BD00	I/O	Data Bus
$\overline{PL1}$	INPUT	Latch enable for byte 1 entered from data bus to transmitter FIFO.
$\overline{PL2}$	INPUT	Latch enable for byte 2 entered from data bus to transmitter FIFO. Must follow $\overline{PL1}$.
TX/R	OUTPUT	Transmitter ready flag. Goes low when ARINC word loaded into FIFO. Goes high after transmission and FIFO empty.
\overline{HFT}	OUTPUT	Transmitter FIFO Half Full
\overline{FFT}	OUTPUT	Transmitter FIFO Full
V-	POWER	-9.5V to -10.5V
TXAOUT	OUTPUT	Line driver output - A side
TXBOUT	OUTPUT	Line driver output - B side
V+	POWER	+9.5V to +10.5V
ENTX	INPUT	Enable Transmission
\overline{CWSTR}	INPUT	Clock for control word register
\overline{RSR}	INPUT	Read Status Register if SEL=0, read Control Register if SEL=1
\overline{NFD}	INPUT	No frequency discrimination if low (pull-up)
CLK	INPUT	Master Clock input
TX CLK	OUTPUT	Transmitter Clock equal to Master Clock (CLK), divided by either 10 or 80.
\overline{MR}	INPUT	Master Reset, active low
TEST	INPUT	Disable Transmitter output if high (pull-down)

FUNCTIONAL DESCRIPTION

CONTROL WORD REGISTER

The HI-85820/HI-85830 contain a 16-bit control register which is used to configure the device. The control register bits CR0 - CR15 are loaded from BD00 - BD15 when \overline{CWSTR} is pulsed low. The control register contents are output on the databus when SEL = 1 and \overline{RSR} is pulsed low. Each bit of the control register has the following function:

CR Bit	FUNCTION	STATE	DESCRIPTION
CR0	Receiver 1 Data clock Select	0	Data rate = CLK/10
		1	Data rate = CLK/80
CR1	Label Memory Read / Write	0	Normal operation
		1	Load 16 labels using $\overline{PL1}$ / $\overline{PL2}$ Read 16 labels using $\overline{EN1}$ / $\overline{EN2}$
CR2	Enable Label Recognition (Receiver 1)	0	Disable label recognition
		1	Enable label recognition
CR3	Enable Label Recognition (Receiver 2)	0	Disable Label Recognition
		1	Enable Label recognition
CR4	Enable 32nd bit as parity	0	Transmitter 32nd bit is data
		1	Transmitter 32nd bit is parity
CR5	Self Test	0	The transmitter's digital outputs are internally connected to the receiver logic inputs
		1	Normal operation
CR6	Receiver 1 decoder	0	Receiver 1 decoder disabled
		1	ARINC bits 9 and 10 must match CR7 and CR8
CR7	-	-	If receiver 1 decoder is enabled, the ARINC bit 9 must match this bit
CR8	-	-	If receiver 1 decoder is enabled, the ARINC bit 10 must match this bit
CR9	Receiver 2 Decoder	0	Receiver 2 decoder disabled
		1	ARINC bits 9 and 10 must match CR10 and CR11
CR10	-	-	If receiver 2 decoder is enabled, the ARINC bit 9 must match this bit
CR11	-	-	If receiver 2 decoder is enabled, the ARINC bit 10 must match this bit
CR12	Invert Transmitter parity	0	Transmitter 32nd bit is Odd parity
		1	Transmitter 32nd bit is Even parity
CR13	Transmitter data clock select	0	Data rate=CLK/10, O/P slope=1.5us
		1	Data rate=CLK/80, O/P slope=10us
CR14	Receiver 2 data clock select	0	Data rate=CLK/10
		1	Data rate=CLK/80
CR15	Data format	0	Scramble ARINC data
		1	Unscramble ARINC data

STATUS REGISTER

The HI-85820/HI-85830 contain a 9-bit status register which can be interrogated to determine the status of the ARINC receivers, data FIFOs and transmitter. The contents of the status register are output on BD00 - BD08 when the \overline{RSR} pin is taken low and SEL = 0. Unused bits are output as Zeros. The following table defines the status register bits.

SR Bit	FUNCTION	STATE	DESCRIPTION
SR0	Data ready (Receiver 1)	0	Receiver 1 FIFO empty
		1	Receiver 1 FIFO contains valid data Resets to zero when all data has been read. $\overline{DR1}$ pin is the inverse of this bit
SR1	FIFO half full (Receiver 1)	0	Receiver 1 FIFO holds less than 16 words
		1	Receiver 1 FIFO holds at least 16 words. $\overline{HF1}$ pin is the inverse of this bit.
SR2	FIFO full (Receiver 1)	0	Receiver 1 FIFO not full
		1	Receiver 1 FIFO full. To avoid data loss, the FIFO must be read within one ARINC word period. $\overline{FF1}$ pin is the inverse of this bit
SR3	Data ready (Receiver 2)	0	Receiver 2 FIFO empty
		1	Receiver 2 FIFO contains valid data Resets to zero when all data has been read. $\overline{DR2}$ pin is the inverse of this bit
SR4	FIFO half full (Receiver 2)	0	Receiver 2 FIFO holds less than 16 words
		1	Receiver 2 FIFO holds at least 16 words. $\overline{HF2}$ pin is the inverse of this bit.
SR5	FIFO full (Receiver 2)	0	Receiver 2 FIFO not full
		1	Receiver 2 FIFO full. To avoid data loss, the FIFO must be read within one ARINC word period. $\overline{FF2}$ pin is the inverse of this bit
SR6	Transmitter FIFO empty	0	Transmitter FIFO not empty
		1	Transmitter FIFO empty.
SR7	Transmitter FIFO full	0	Transmitter FIFO not full
		1	Transmitter FIFO full. \overline{FFT} pin is the inverse of this bit.
SR8	Transmitter FIFO half full	0	Transmitter FIFO contains less than 16 words
		1	Transmitter FIFO contains at least 16 words. \overline{HFT} pin is the inverse of this bit.

FUNCTIONAL DESCRIPTION (cont.)

ARINC 429 DATA FORMAT

Control register bit CR15 is used to control how individual bits in the received or transmitted ARINC word are mapped to the HI-85820/ HI-85830 data bus during data read or write operations. The following table describes this mapping:

BYTE 1																
DATA BUS	BD 15	BD 14	BD 13	BD 12	BD 11	BD 10	BD 09	BD 08	BD 07	BD 06	BD 05	BD 04	BD 03	BD 02	BD 01	BD 00
ARINC BIT CR15=0	13	12	11	10	9	31	30	32	1	2	3	4	5	6	7	8
ARINC BIT CR15=1	16	15	14	13	12	11	10	9	8	7	6	5	4	3	2	1

BYTE 2																
DATA BUS	BD 15	BD 14	BD 13	BD 12	BD 11	BD 10	BD 09	BD 08	BD 07	BD 06	BD 05	BD 04	BD 03	BD 02	BD 01	BD 00
ARINC BIT CR15=0	29	28	27	26	25	24	23	22	21	20	19	18	17	16	15	14
ARINC BIT CR15=1	32	31	30	29	28	27	26	25	24	23	22	21	20	19	18	17

THE RECEIVERS

ARINC BUS INTERFACE

Figure 1 shows the input circuit for each receiver. The ARINC 429 specification requires the following detection levels:

STATE	DIFFERENTIAL VOLTAGE
ONE	+6.5 Volts to +13 Volts
NULL	+2.5 Volts to -2.5 Volts
ZERO	-6.5 Volts to -13 Volts

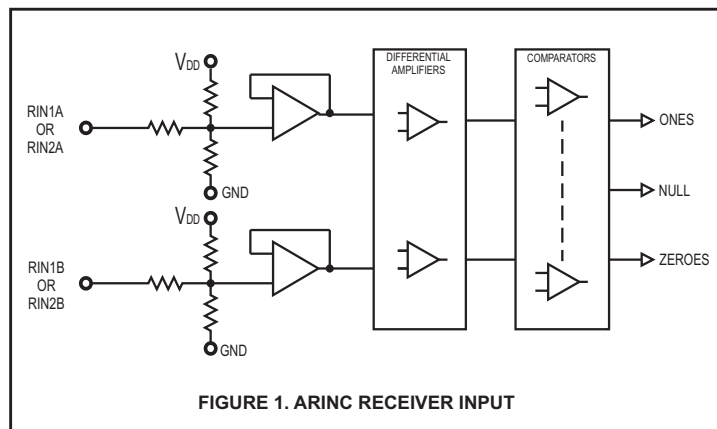

The HI-85820/HI-85830 guarantee recognition of these levels with a common mode Voltage with respect to GND less than $\pm 4V$ for the worst case condition (4.75V supply and 13V signal level).

The tolerances in the design guarantee detection of the above levels, so the actual acceptance ranges are slightly larger. If the ARINC signal is out of the actual acceptance ranges, including the nulls, the chip rejects the data.

RECEIVER LOGIC OPERATION

Figure 2 shows a block diagram of the logic section of each receiver.

BIT TIMING

The ARINC 429 specification contains the following timing specification for the received data:

	HIGH SPEED	LOW SPEED
BIT RATE	100 kbps \pm 1%	12K -14.5 kbps
PULSE RISE TIME	1.5 \pm 0.5 μ sec	10 \pm 5 μ sec
PULSE FALL TIME	1.5 \pm 0.5 μ sec	10 \pm 5 μ sec
PULSE WIDTH	5 μ sec \pm 5%	34.5 to 41.7 μ sec

If the \overline{NFD} pin is high, the HI-85820/HI-85830 accept signals that meet these specifications and rejects signals outside the tolerances. The way the logic operation achieves this is described below:

1. Key to the performance of the timing checking logic is an accurate 1MHz clock source. Less than 0.1% error is recommended.
2. The sampling shift registers are 10 bits long and must show three consecutive Ones, Zeros or Nulls to be considered valid data. Additionally, for data bits, the One or Zero in the upper bits of the sampling shift registers must be followed by a Null in the lower bits within the data bit time. For a Null in the word gap, three consecutive Nulls must be found in both the upper and lower bits of the sampling shift register. In this manner the minimum pulse width is guaranteed.
3. Each data bit must follow its predecessor by not less than 8 samples and no more than 12 samples. In this manner the bit rate is checked. With exactly 1MHz input clock frequency, the acceptable data bit rates are as follows:

	HIGH SPEED	LOW SPEED
DATA BIT RATE MIN	83 kbps	10.4 kbps
DATA BIT RATE MAX	125 kbps	15.6 kbps

4. The Word Gap timer samples the Null shift register every 10 input clocks (80 for low speed) after the last data bit of a valid reception. If the Null is present, the Word Gap counter is incremented. A count of 3 will enable the next reception.

If \overline{NFD} is held low, frequency discrimination is disabled and any data stream totaling 32 bits is accepted even with gaps between bits. The protocol still requires a word gap as defined in 4. above.

FUNCTIONAL DESCRIPTION (cont.)

RECEIVER PARITY

The 32nd bit of received ARINC words stored in the receive FIFO is used as a Parity Flag indicating whether good Odd parity is received from the incoming ARINC word.

Odd Parity Received

The parity bit is reset to indicate correct parity was received and the resulting word is written to the receive FIFO.

Even Parity Received

The receiver sets the 32nd bit to a "1", indicating a parity error and the resulting word is then written to the receive FIFO.

Therefore, the 32nd bit retrieved from the receiver FIFO will always be "0" when valid (odd parity) ARINC 429 words are received.

ARINC words which do not meet the necessary 9th and 10th ARINC bit or label matching are ignored and are not loaded into the receive FIFO. The following table describes this operation.

CR2(3)	ARINC word matches label	CR6(9)	ARINC word bits 9,10 match CR7,8 (10,11)	FIFO
0	X	0	X	Load FIFO
1	No	0	X	Ignore data
1	Yes	0	X	Load FIFO
0	X	1	No	Ignore data
0	X	1	Yes	Load FIFO
1	Yes	1	No	Ignore data
1	No	1	Yes	Ignore data
1	No	1	No	Ignore data
1	Yes	1	Yes	Load FIFO

RETRIEVING DATA

Once 32 valid bits are recognized, the receiver logic generates an End of Sequence (EOS). Depending upon the state of control register bits CR2-CR11, the received ARINC 32-bit word is then checked for correct decoding and label matching before being loaded into the 32 x 32 receive FIFO.

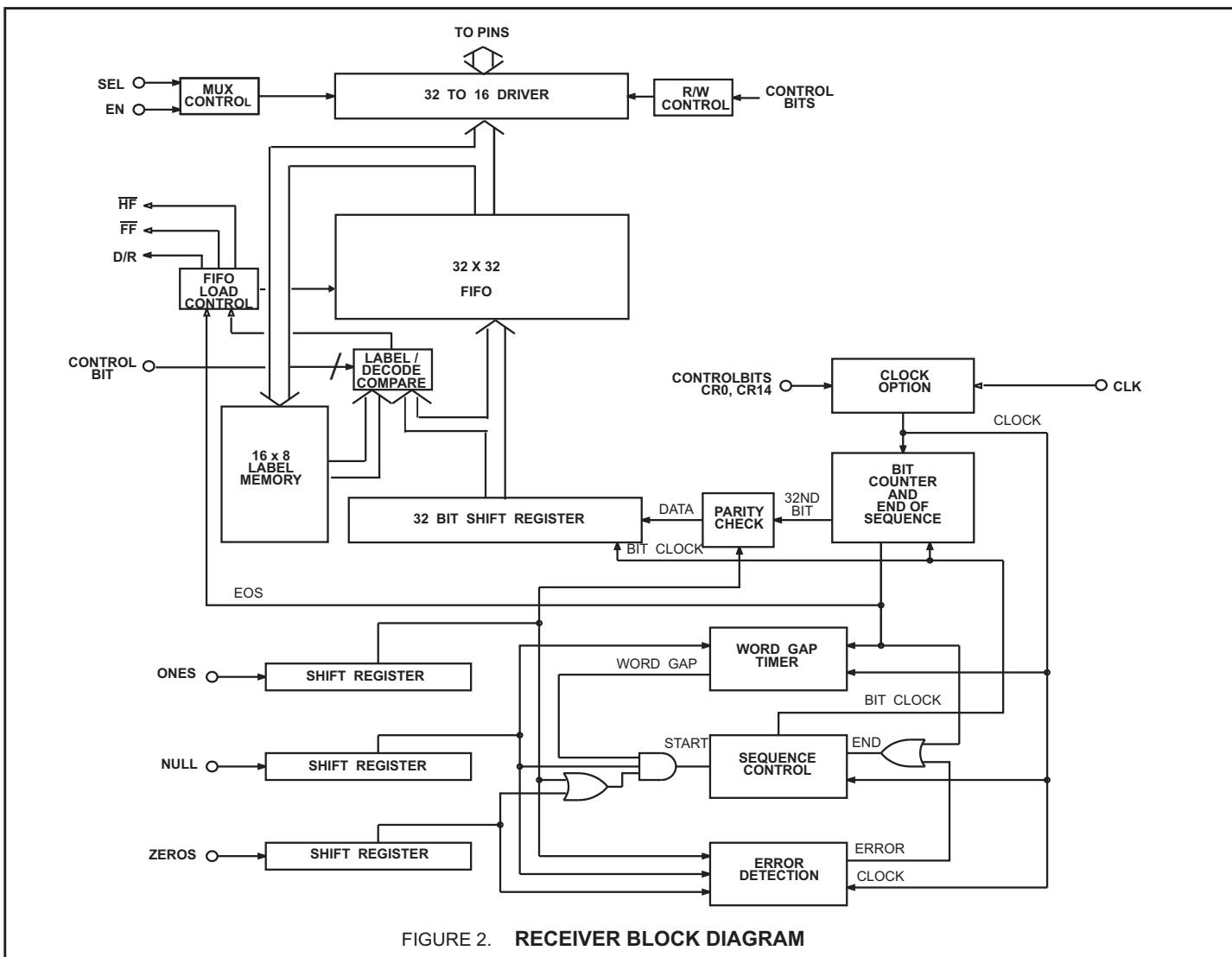

FIGURE 2. RECEIVER BLOCK DIAGRAM

FUNCTIONAL DESCRIPTION (cont.)

Once a valid ARINC word is loaded into the FIFO, then EOS clocks the data ready flag flip flop to a "1", $\overline{D/R1}$ or $\overline{D/R2}$ (or both) will go low. The data flag for a receiver will remain low until both ARINC bytes from that receiver are retrieved and the FIFO is empty. This is accomplished by first activating \overline{EN} with SEL, the byte selector, low to retrieve the first byte and then activating \overline{EN} with SEL high to retrieve the second byte. $\overline{EN1}$ retrieves data from receiver 1 and $\overline{EN2}$ retrieves data from receiver 2.

Up to 32 ARINC words may be loaded into each receiver's FIFO. The $\overline{FF1}$ ($\overline{FF2}$) pin will go low when the receiver 1 (2) FIFO is full. Failure to retrieve data from a full FIFO will cause the next valid ARINC word received to overwrite the existing data in FIFO location 32. A FIFO half full flag $\overline{HF1}$ ($\overline{HF2}$) goes low if the FIFO contains 16 or more received ARINC words. The $\overline{HF1}$ ($\overline{HF2}$) pin is intended to act as an interrupt flag to the system's external microprocessor, allowing a 16 word data retrieval routine to be performed, without the user needing to continually poll the HI-85820/HI-85830 status register bits.

LABEL RECOGNITION

The chip compares the incoming label to the stored labels if label recognition is enabled. If a match is found, the data is processed. If a match is not found, no indicators of receiving ARINC data are presented. Note that 00(Hex) is treated in the same way as any other label value. Label bit significance is not changed by the status of control register bit CR15. Label bits BD00 - BD07 are always compared to received ARINC bits 1 - 8 respectively.

LOADING LABELS

After a write that takes CR1 from 0 to 1, the next 16 writes of data (\overline{PL} pulsed low) load label data into each location of the label memory from the BD00 - BD07 pins. The $\overline{PL1}$ pin is used to write label data for receiver 1 and $\overline{PL2}$ for receiver 2. Note that ARINC word reception is suspended during the label memory write sequence.

READING LABELS

After the write that changes CR1 from 0 to 1, the next 16 data reads of the selected receiver (\overline{EN} taken low) are labels. $\overline{EN1}$ is used to read labels for receiver 1, and $\overline{EN2}$ to read labels for receiver 2. Label data is presented on BD0-BD7.

When writing to, or reading from the label memory, SEL must be a one, all 16 locations should be accessed, and CR1 must be written to zero before returning to normal operation. Label recognition must be disabled ($CR2/3=0$) during the label read sequence.

TRANSMITTER

FIFO OPERATION

The FIFO is loaded sequentially by first pulsing $\overline{PL1}$ to load byte 1 and then $\overline{PL2}$ to load byte 2. The control logic automatically loads the 31 bit word (or 32 bit word if $CR4=0$) in the next available position of the FIFO. If TX/R, the transmitter ready flag is high (FIFO empty), then up to 32 words, each 31 or 32 bits long, may be loaded. If TX/R is low, then only the available positions may be loaded. If all 32 positions are full, the \overline{FFT} flag is asserted and the FIFO ignores further attempts to load data.

A transmitter FIFO half-full flag \overline{HFT} is provided. When the transmit FIFO contains less than 16 words, \overline{HFT} is high, indicating to the system microprocessor that a 16 ARINC word block write sequence can be initiated.

In normal operation ($CR4=1$), the 32nd bit transmitted is a parity bit. Odd or even parity is selected by programming control register bit CR12 to a zero or one. If CR4 is programmed to a 0, then all 32-bits of data loaded into the transmitter FIFO are treated as data and are transmitted.

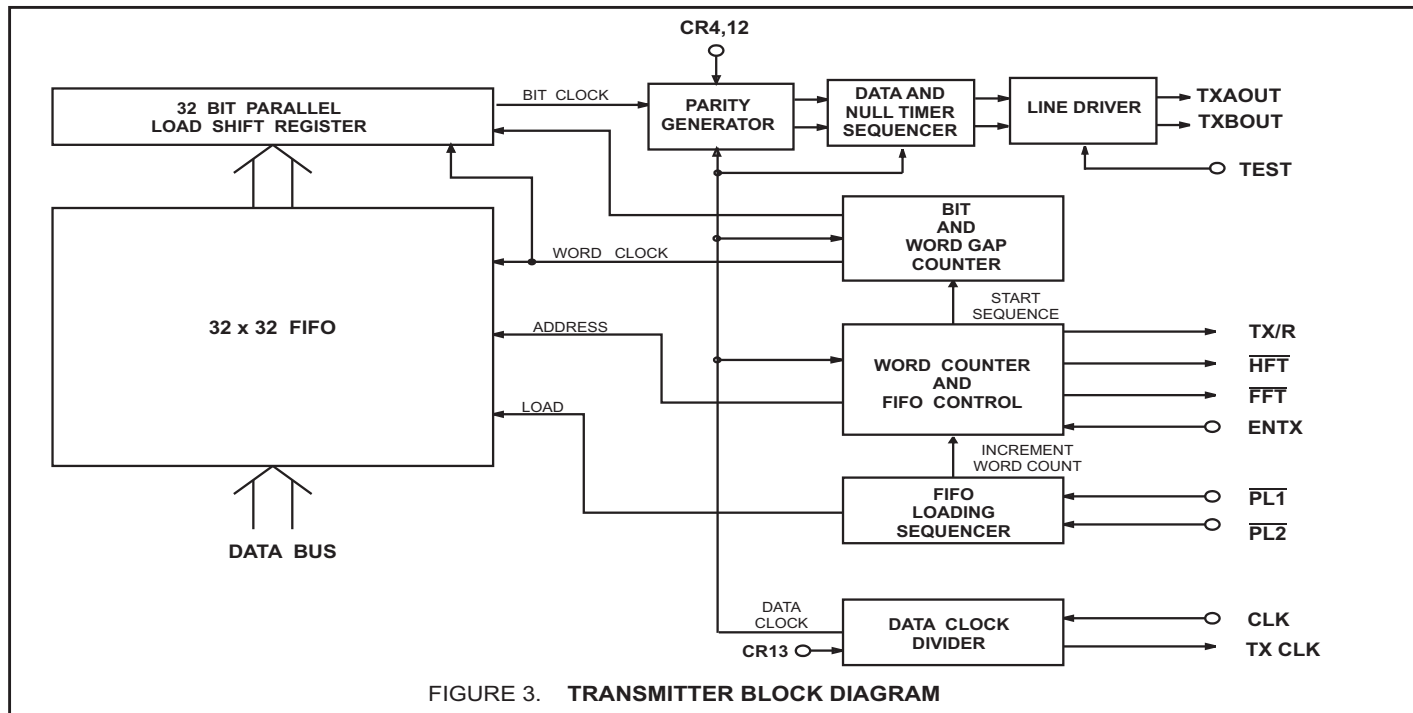

FIGURE 3. TRANSMITTER BLOCK DIAGRAM

FUNCTIONAL DESCRIPTION (cont.)

DATA TRANSMISSION

When ENTX goes high, enabling transmission, the FIFO positions are incremented with the top register loading into the data transmission shift register. Within 2.5 data clocks the first data bit appears at TXAOUT and TXBOUT. The 31 or 32 bits in the data transmission shift register are presented sequentially to the outputs in the ARINC 429 format with the following timing:

	<u>HIGH SPEED</u>	<u>LOW SPEED</u>
ARINC DATA BIT TIME	10 Clocks	80 Clocks
DATA BIT TIME	5 Clocks	40 Clocks
NULL BIT TIME	5 Clocks	40 Clocks
WORD GAP TIME	40 Clocks	320 Clocks

The word counter detects when all loaded positions have been transmitted and sets the transmitter ready flag, TX/R, high.

TRANSMITTER PARITY

The parity generator counts the Ones in the 31-bit word. If control register bit CR12 is set low, the 32nd bit transmitted will make parity odd. If the control bit is high, the parity is even. Setting CR4 to a Zero bypasses the parity generator, and allows 32 bits of data to be transmitted.

SELF TEST

If control register bit CR5 is set low, the transmitter serial output data are internally connected to each of the two receivers, bypassing the analog interface circuitry. Data is passed unmodified to receiver 1 and inverted to receiver 2. Taking TEST high forces TXAOUT and TXBOUT into the null state regardless of the state of CR5.

SYSTEM OPERATION

The two receivers are independent of the transmitter. Therefore, control of data exchanges is strictly at the option of the user. The only restrictions are:

1. The received data will be overwritten if the receiver FIFO is full and at least one location is not retrieved before the next complete ARINC word is received.
2. The transmitter FIFO can store 32 words maximum and ignores attempts to load additional data if full.

LINE DRIVER OPERATION

The line driver in the HI-85820/HI-85830 are designed to directly drive the ARINC 429 bus. The two ARINC outputs (TXAOUT and TXBOUT) provide a differential voltage to produce a +10 volt One, a -10 volt Zero, and a 0 volt Null. Control register bit CR13 controls both the transmitter data rate, and the slope of the differential output signal. No additional hardware is required to control the slope. Programming CR13 to Zero causes a 100 kbits/s data rate and a slope of 1.5 μ s on the ARINC outputs; a One on CR13 causes a 12.5 kbit/s data rate and a slope of 10 μ s. Timing is set by on-chip resistor and capacitor and tested to be within ARINC requirements.

The HI-85820 has 37.5 ohms in series with each line driver output. The HI-85830 has 10 ohms in series. The HI-85830 is for applications where external series resistance is needed, typically for lightning protection devices.

REPEATER OPERATION

Repeater mode of operation allows a data word that has been received by the HI-85820/HI-85830 to be placed directly into the transmitter FIFO. Repeater operation is similar to normal receiver operation. In normal operation, either byte of a received data word may be read from the receiver latches first by use of SEL input. During repeater operation however, the lower byte of the data word must be read first. This is necessary because, as the data is being read, it is also being loaded into transmitter FIFO which is always loaded with the lower byte of the data word first. Signal flow for repeater operation is shown in the Timing Diagrams section.

HI-85820-10 and HI-85830-10

The HI-85820-10/HI-85830-10 options are similar to the HI-85820/HI-85830 with the exception that they allow an external 10 kOhm resistor to be added in series with each ARINC input without affecting the ARINC input thresholds. This option is especially useful in applications where lightning protection circuitry is also required.

Each side of the ARINC bus must be connected through a 10 kOhm series resistor in order for the chip to detect the correct ARINC levels. The typical 10 volt differential signal is translated and input to a window comparator and latch. The comparator levels are set so that with the external 10 kOhm resistors, they are just below the standard 6.5 volt minimum ARINC data threshold and just above the standard 2.5 volt maximum ARINC null threshold.

Please refer to the Holt AN-300 Application Note for additional information and recommendations on lightning protection of Holt line drivers and line receivers.

HIGH SPEED OPERATION

The HI-85820 and HI-85830 may be operated at clock frequencies beyond that required for ARINC compliant operation. For operation at Master Clock (CLK) frequencies up to 5MHz, please contact Holt applications engineering.

POWER SUPPLY SEQUENCING

The power supplies should be controlled to prevent large currents during supply turn-on and turn-off. The recommended sequence is V+ followed by V_{DD}, always ensuring that V+ is the most positive supply. The V- supply is not critical and can be asserted at any time.

MASTER RESET (\overline{MR})

On a Master Reset data transmission and reception are immediately terminated, all three FIFOs are cleared as are the FIFO flags at the device pins and in the Status Register. The Control Register is not affected by a Master Reset.

TIMING DIAGRAMS

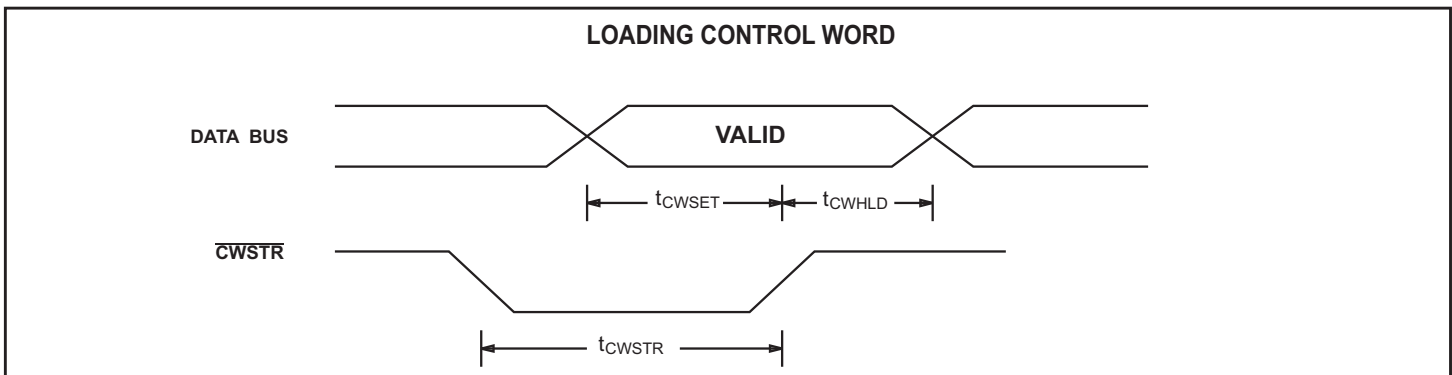
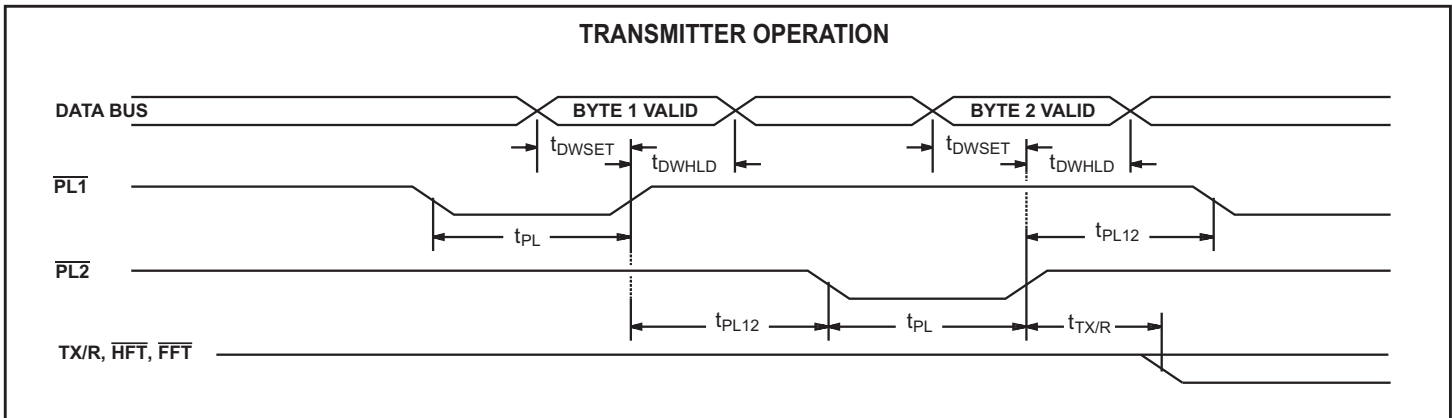
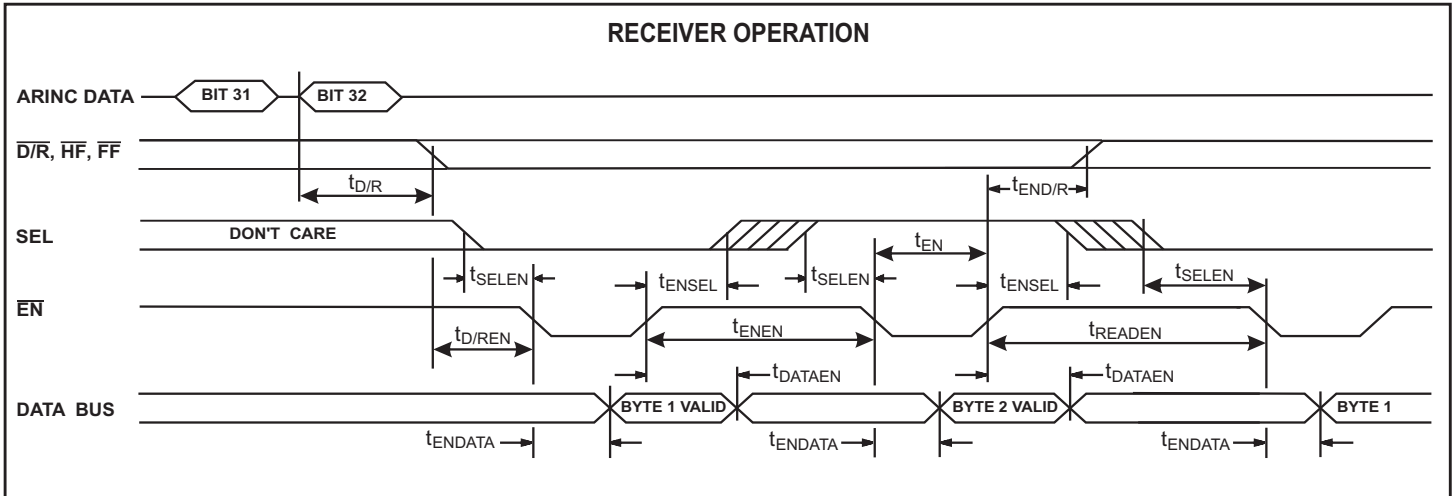
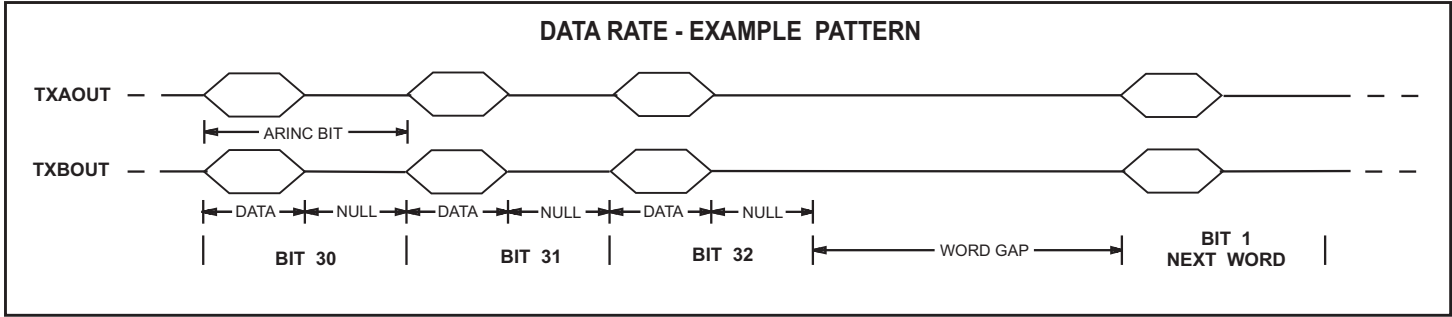

TIMING DIAGRAMS (cont.)

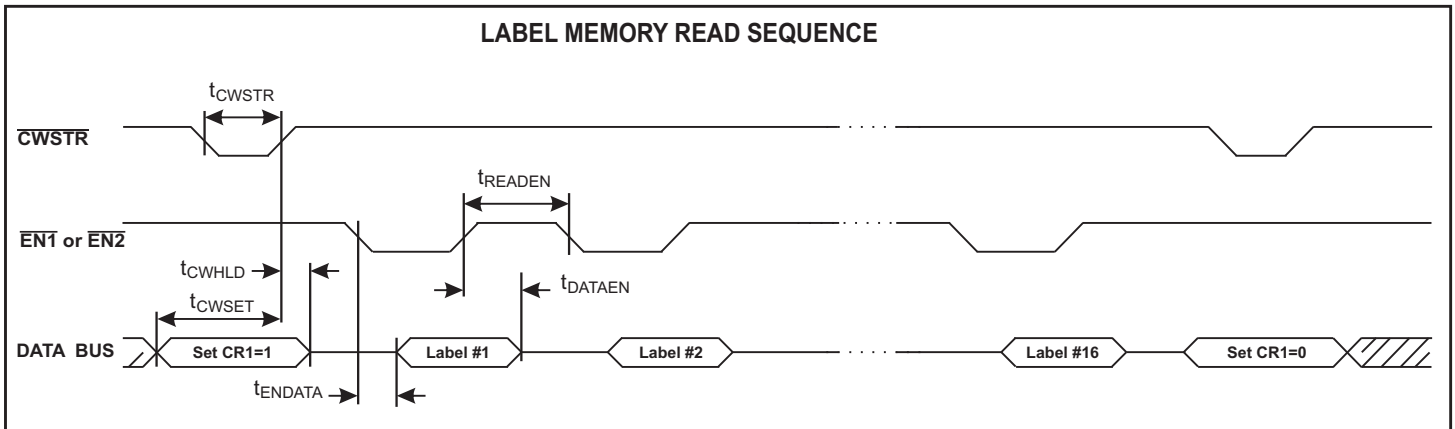
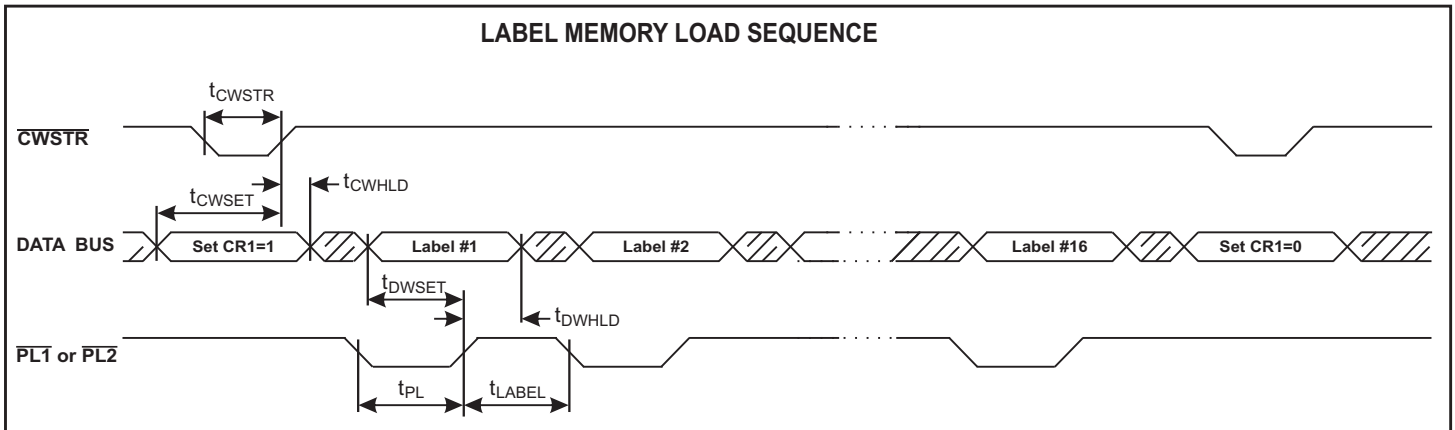
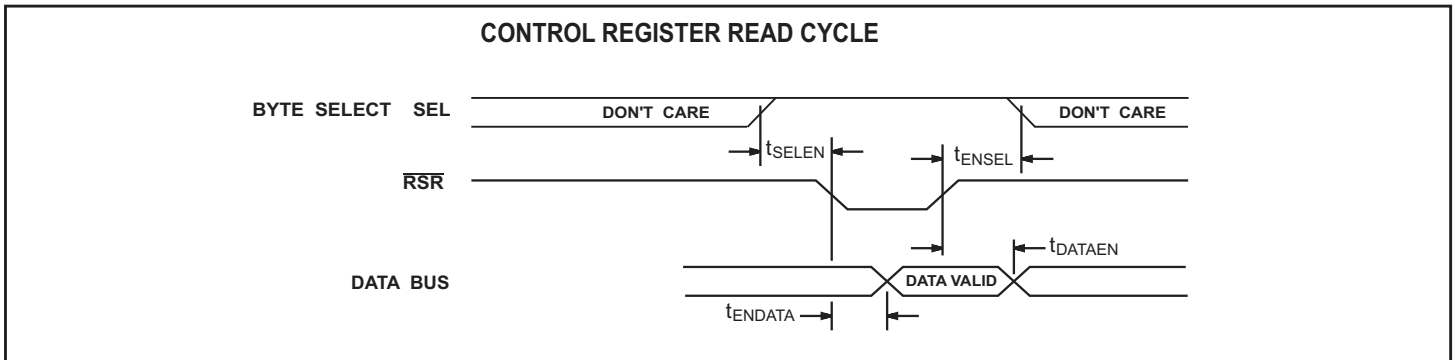
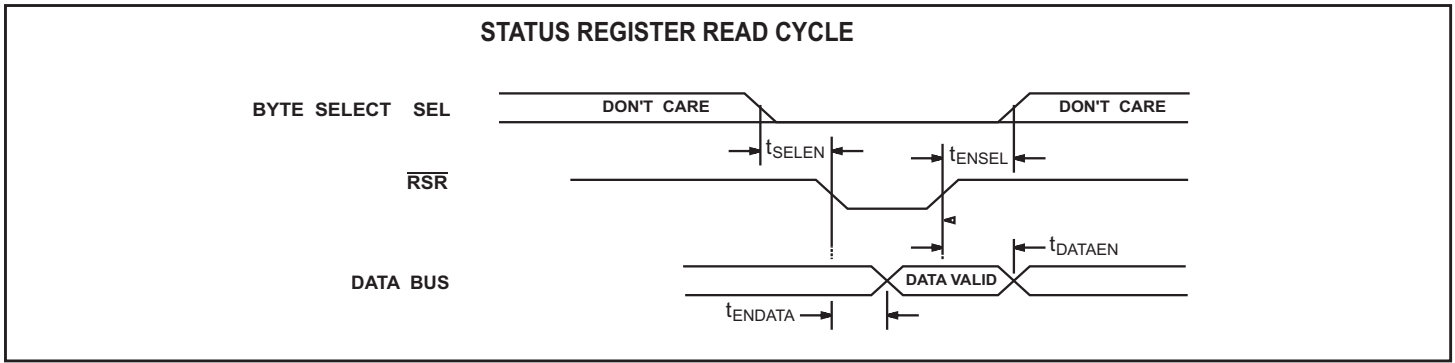

TIMING DIAGRAMS (cont.)

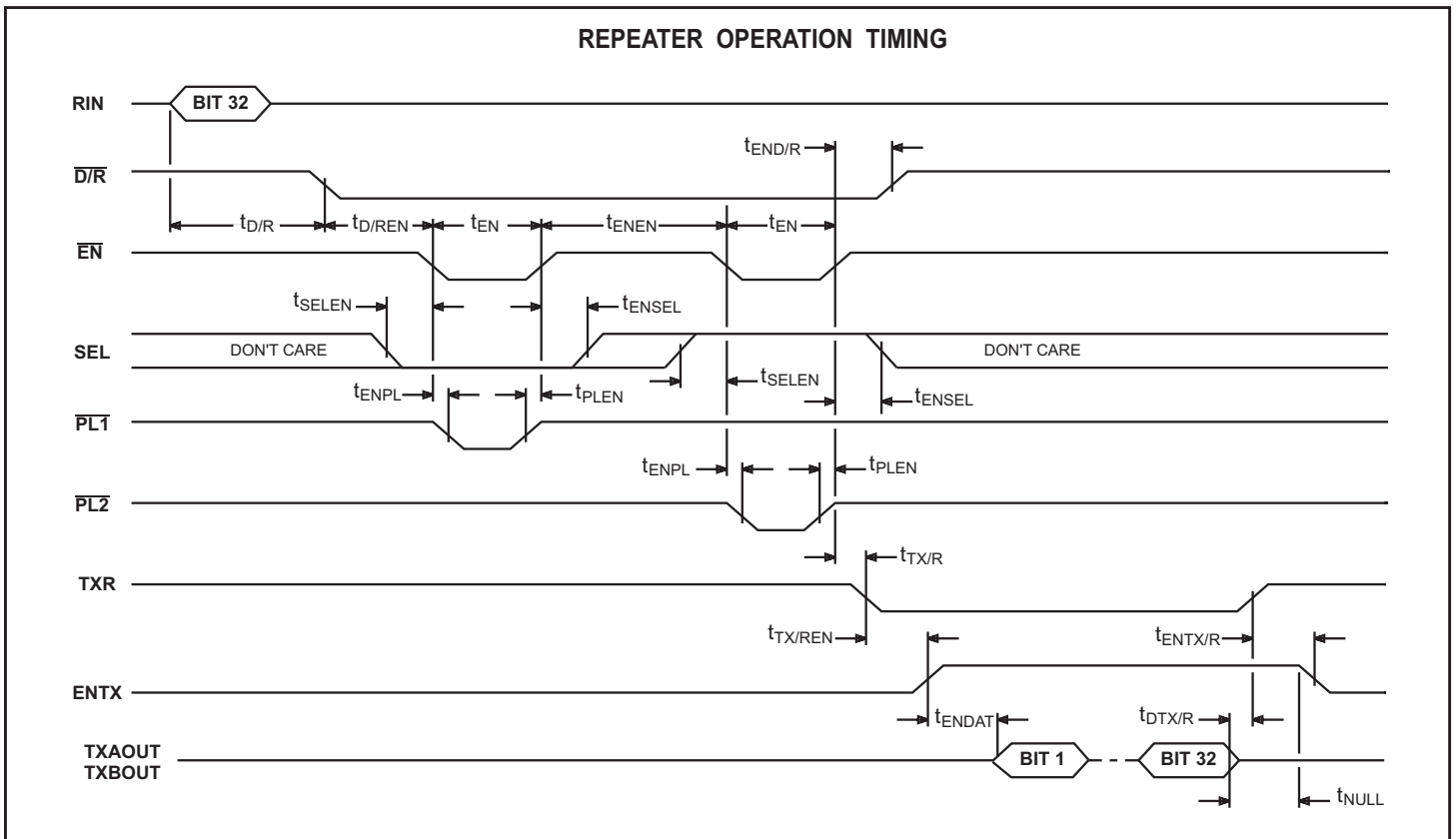
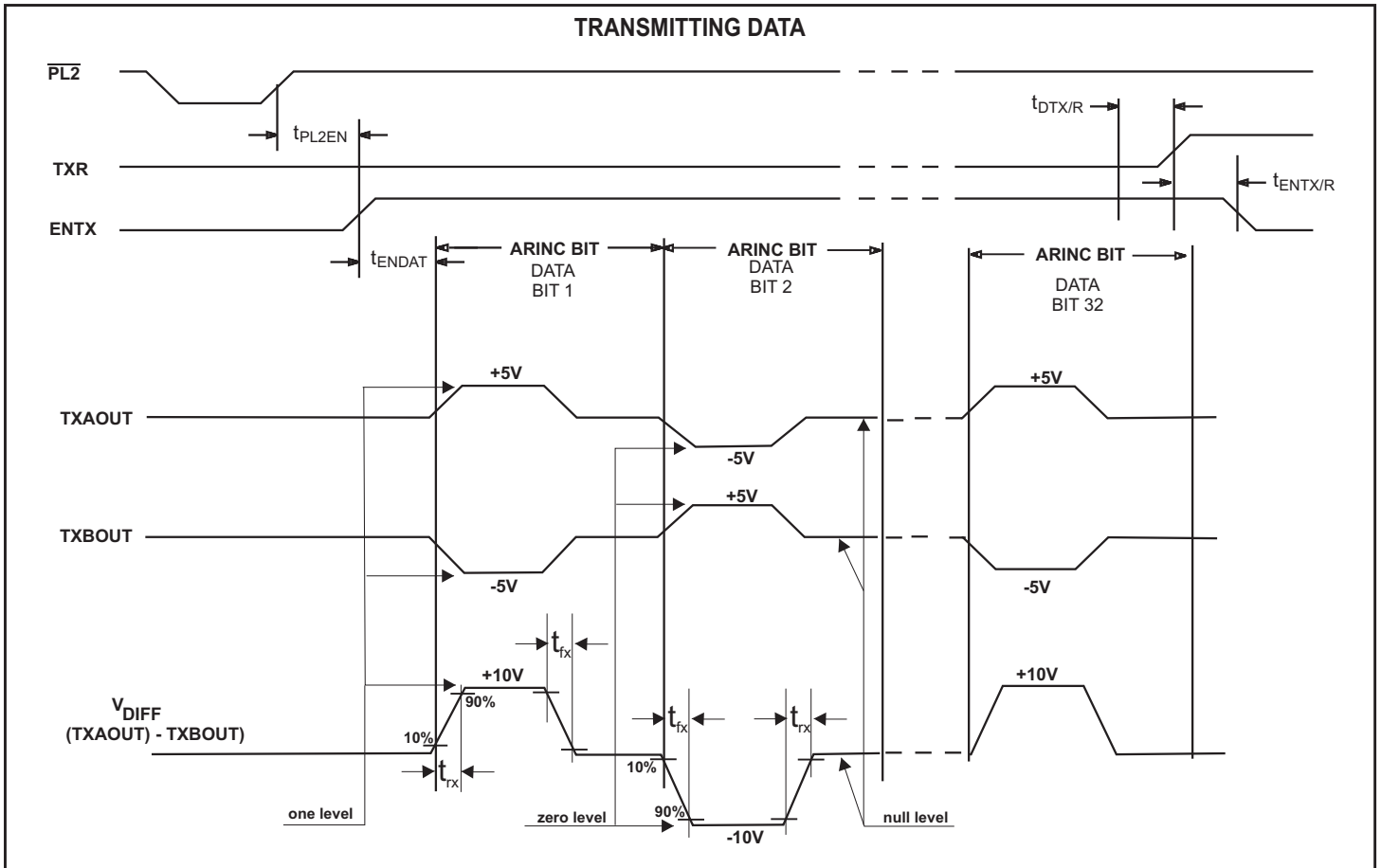

ABSOLUTE MAXIMUM RATINGS

Supply Voltages V _{DD} -0.3V to +7V V ₊ +12.5V V ₋ -12.5V	Power Dissipation at 25°C Plastic Quad Flat Pack 1.5 W, derate 10mW/°C Ceramic J-LEAD CERQUAD 1.0 W, derate 7mW/°C
Voltage at pins RIN1A/1B, RIN2A/2B (DC) -120V to +120V (AC) 120Vrms @ 400Hz	DC Current Drain per pin ±10mA
Voltage at any other pin -0.3V to V _{DD} +0.3V	Storage Temperature Range -65°C to +150°C
Solder temperature (reflow) 260°C	Operating Temperature Range (Industrial): -40°C to +85°C (Extended): -55°C to +125°C

NOTE: Stresses above those listed under "Absolute Maximum Ratings" may cause permanent damage to the device. These are stress ratings only. Functional operation of the device at these or any other conditions above those indicated in the operational sections of the specifications is not implied. Exposure to absolute maximum rating conditions for extended periods may affect device reliability.

DC ELECTRICAL CHARACTERISTICS

V_{DD} = 5V, V₊ = 10V, V₋ = -10V, GND = 0V, TA = Operating Temperature Range (unless otherwise specified).

PARAMETER	SYMBOL	CONDITIONS	LIMITS			UNIT		
			MIN	TYP	MAX			
ARINC INPUTS - Pins RIN1A, RIN1B, RIN2A, RIN2B								
Differential Input Voltage: (RIN1A to RIN1B, RIN2A to RIN2B)	ONE	V _{IH}	Common mode voltages less than ±4V with respect to GND	6.5	10.0	13.0	V	
	ZERO	V _{IL}		-13.0	-10.0	-6.5	V	
	NULL	V _{NUL}		-2.5	0	2.5	V	
Input Resistance:	Differential	R _I		12	46		kΩ	
	To GND	R _G		12	38		kΩ	
	To V _{DD}	R _H		12	38		kΩ	
Input Current:	Input Sink	I _{IH}		-450		200	μA	
	Input Source	I _{IL}					μA	
Input Capacitance: (Guaranteed but not tested)	Differential	C _I	(RIN1A to RIN1B, RIN2A to RIN2B)			20	pF	
	To GND	C _G					20	pF
	To V _{DD}	C _H					20	pF
BI-DIRECTIONAL INPUTS - Pins BD00 - BD15								
Input Voltage:	Input Voltage HI	V _{IH}		2.0		0.8	V	
	Input Voltage LO	V _{IL}					V	
Input Current:	Input Sink	I _{IH}		-1.5		1.5	μA	
	Input Source	I _{IL}					μA	
OTHER INPUTS								
Input Voltage:	Input Voltage HI	V _{IH}		2.0		0.8	V	
	Input Voltage LO	V _{IL}					V	
Input Current:	Input Sink	I _{IH}		-1.5		1.5	μA	
	Input Source	I _{IL}					μA	
	Pull-up current (NFD Pin)	I _{PU}					μA	
	Pull-down Current (TEST Pin)	I _{PD}					700	μA
ARINC OUTPUTS - Pins TXAOUT, TXBOUT								
ARINC output voltage (Ref. To GND)	One or zero	V _{DOUT}	No load and magnitude at pin, V _{DD} = 5.0 V	4.50	5.00	5.50	V	
	Null	V _{NOUT}		-0.25		0.25	V	
ARINC output voltage (Differential)	One or zero	V _{DDIF}	No load and magnitude at pin, V _{DD} = 5.0 V	9.0	10.0	11.0	V	
	Null	V _{NDIF}		-0.5		0.5	V	
ARINC output current		I _{OUT}		80			mA	
OTHER OUTPUTS								
Output Voltage:	Logic "1" Output Voltage	V _{OH}	I _{OH} = -1.5mA I _{OL} = 1.6mA	2.7		0.4	V	
	Logic "0" Output Voltage	V _{OL}					V	
Output Current: (All Outputs & Bi-directional Pins)	Output Sink	I _{OL}	V _{OUT} = 0.4V V _{OUT} = V _{DD} - 0.4V	1.6		-1.0	mA	
	Output Source	I _{OH}					mA	
Output Capacitance:		C _O			15		pF	
Operating Voltage Range								
	V _{DD}			4.75		5.25	V	
	V ₊			9.5		10.5	V	
	V ₋			-9.5		-10.5	V	
Operating Supply Current								
V _{DD}	I _{DD1}					20	mA	
V ₊	I _{DD2}					16	mA	
V ₋	I _{EE1}					16	mA	

AC ELECTRICAL CHARACTERISTICS

VDD = 5V, V+=10V, V--=10V, GND = 0V, TA = Oper. Temp. Range and fclk=1MHz ±0.1% with 60/40 duty cycle

PARAMETER	SYMBOL	LIMITS			UNITS	
		MIN	TYP	MAX		
CONTROL WORD TIMING						
Pulse Width - \overline{CWSTR}	tCWSTR	80			ns	
Setup - DATA BUS Valid to \overline{CWSTR} HIGH	tCWSET	50			ns	
Hold - \overline{CWSTR} HIGH to DATA BUS Hi-Z	tCWHLD	0			ns	
RECEIVER FIFO AND LABEL READ TIMING						
Delay - Start ARINC 32nd Bit to $\overline{D/R}$ LOW: High Speed	tD/R			16	µs	
Low Speed	tD/R			128	µs	
Delay - $\overline{D/R}$ LOW to \overline{EN} LOW	tD/REN	0	250	350	ns	
Delay - \overline{EN} HIGH to $\overline{D/R}$ HIGH	tEND/R				ns	
Setup - SEL to \overline{EN} LOW	tSELEN	10			ns	
Hold - SEL to \overline{EN} HIGH	tENSEL	10			ns	
Delay - \overline{EN} LOW to DATA BUS Valid	tENDATA		60	100	ns	
Delay - \overline{EN} HIGH to DATA BUS Hi-Z	tDATAEN		50	80	ns	
Pulse Width - $\overline{EN1}$ or $\overline{EN2}$	tEN	60			ns	
Spacing - \overline{EN} HIGH to next \overline{EN} LOW (Same ARINC Word)	tENEN	60			ns	
Spacing - \overline{EN} HIGH to next \overline{EN} LOW (Next ARINC Word)	tREADEN	200			ns	
TRANSMITTER FIFO AND LABEL WRITE TIMING						
Pulse Width - $\overline{PL1}$ or $\overline{PL2}$	tPL	80			ns	
Setup - DATA BUS Valid to \overline{PL} HIGH	tDWSET	105			ns	
Hold - \overline{PL} HIGH to DATA BUS Hi-Z	tDWHLD	10			ns	
Spacing - $\overline{PL1}$ or $\overline{PL2}$	tPL12	85			ns	
Spacing between Label Write pulses	tLABEL	200			ns	
Delay - $\overline{PL2}$ HIGH to TX/R LOW	tTX/R			300	ns	
TRANSMISSION TIMING						
Spacing - $\overline{PL2}$ HIGH to ENTX HIGH	tPL2EN	0			µs	
Delay - 32nd ARINC Bit to TX/R HIGH	tDTX/R			50	ns	
Spacing - TX/R HIGH to ENTX LOW	tENTX/R	0			ns	
LINE DRIVER OUTPUT TIMING						
Delay - ENTX HIGH to TXAOUT or TXBOUT: High Speed	tENDAT			25	µs	
Delay - ENTX HIGH to TXAOUT or TXBOUT: Low Speed	tENDAT			200	µs	
Line driver transition differential times:						
(High Speed, control register CR13 = Logic 0)	high to low	tfx	1.0	1.5	2.0	µs
	low to high	trx	1.0	1.5	2.0	µs
(Low Speed, control register CR13 = Logic 1)	high to low	tfx	5.0	10	15	µs
	low to high	trx	5.0	10	15	µs
REPEATER OPERATION TIMING						
Delay - \overline{EN} LOW to \overline{PL} LOW	tENPL	0			ns	
Hold - \overline{PL} HIGH to \overline{EN} HIGH	tPLEN	0			ns	
Delay - TX/R LOW to ENTX HIGH	tTX/REN	0			ns	
MASTER RESET PULSE WIDTH						
	tMR	50			ns	
ARINC DATA RATE AND BIT TIMING						
				± 1%		

ADDITIONAL HI-85820 / HI-85830 PIN CONFIGURATIONS

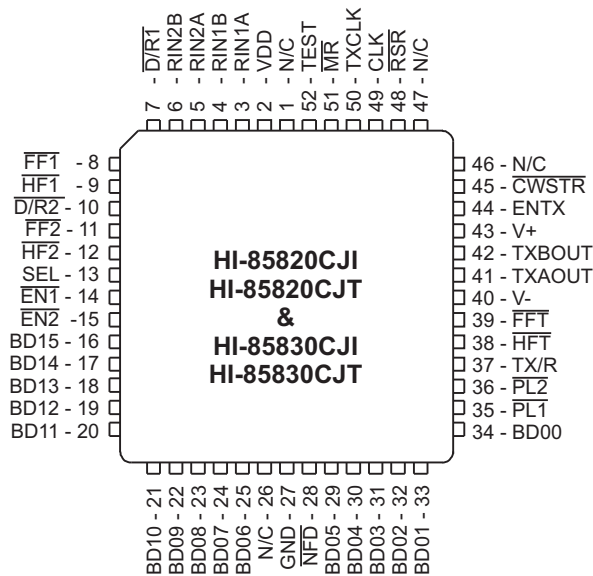

52 - Pin Cerquad J-lead
(See page 1 for additional pin configuration)

ORDERING INFORMATION

HI - 85xxx xx x x - xx

PART NUMBER	INPUT SERIES RESISTANCE	
	BUILT-IN	REQUIRED EXTERNALLY
No dash number	35 kOhm	0
-10	25 kOhm	10 kOhm

PART NUMBER	LEAD FINISH
Blank	Tin / Lead (Sn / Pb) Solder
F	100% Matte Tin (Pb-free, RoHS compliant)

PART NUMBER	TEMPERATURE RANGE	FLOW	BURN IN
I	-40°C TO +85°C	I	NO
T	-55°C TO +125°C	T	NO
M	-55°C TO +125°C	M	YES

PART NUMBER	PACKAGE DESCRIPTION
CJ	52 PIN CERQUAD J LEAD (52U) not available Pb-free
PQ	52 PIN PLASTIC QUAD FLAT PACK PQFP (52PQS)

PART NUMBER	OUTPUT SERIES RESISTANCE	
	BUILT-IN	REQUIRED EXTERNALLY
85820	37.5 Ohms	0
85830	10 Ohms	27.5 Ohms

REVISION HISTORY

P/N	Revision	Date	Description of Change
DS85820	New	01/21/2021	Initial Release.

52-PIN J-LEAD CERQUAD

inches (millimeters)

Package Type: 52U

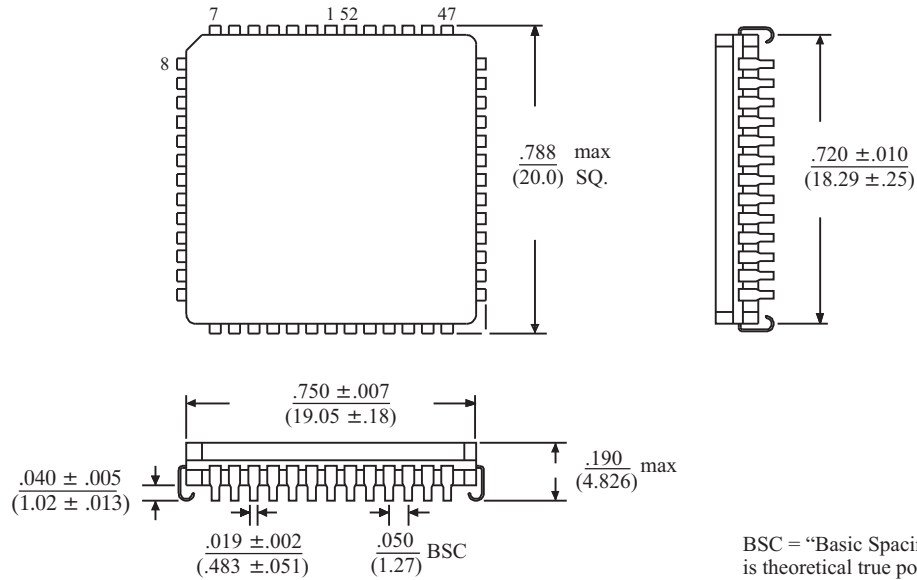

BSC = "Basic Spacing between Centers" is theoretical true position dimension and has no tolerance. (JEDEC Standard 95)

52-PIN PLASTIC QUAD FLAT PACK (PQFP)

millimeters (inches)

Package Type: 52PQS

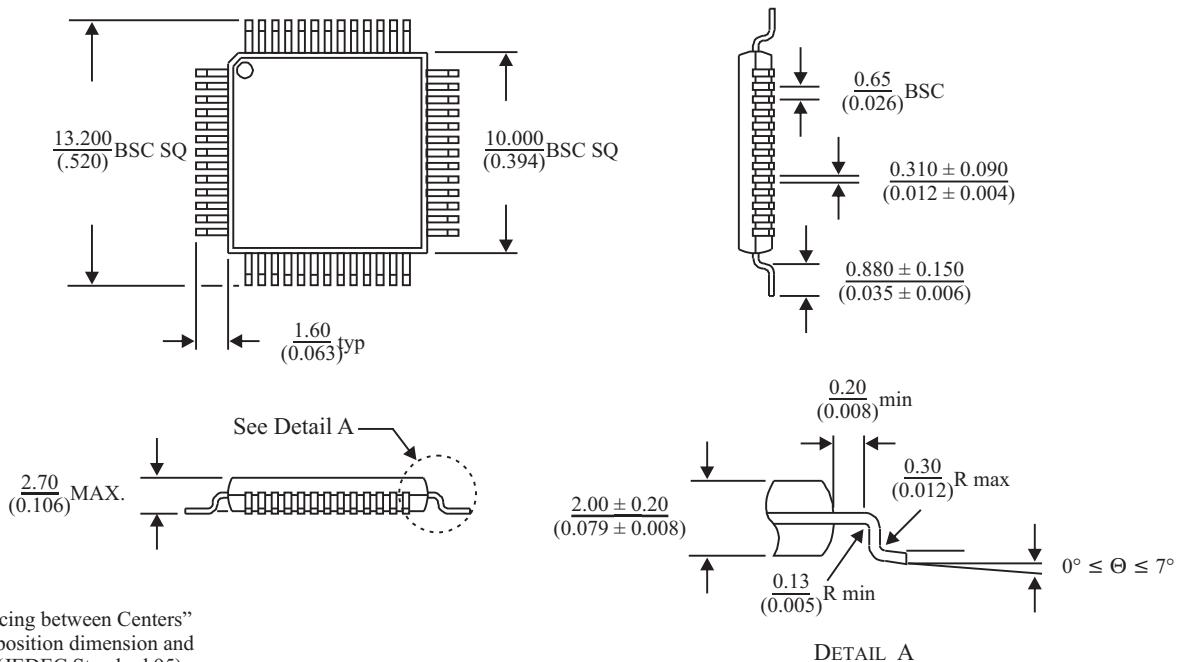

BSC = "Basic Spacing between Centers" is theoretical true position dimension and has no tolerance. (JEDEC Standard 95)