

C8205B-0005

C Jack Clamp For Bulkhead 50Ω

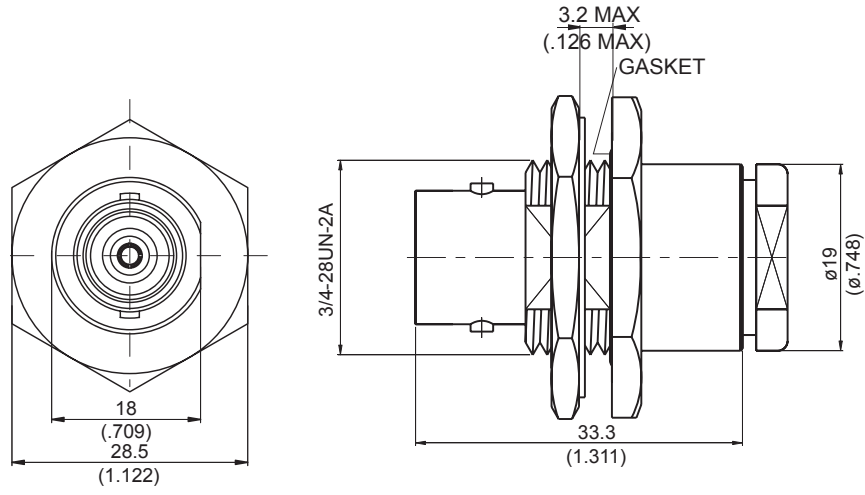

MOUNTING HOLE :

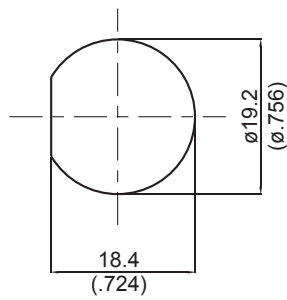

Parts	Material	Plating(Micro-inch)
Hex Nut	Brass	Tin-Zinc-Copper-Alloy 100 Over Copper 50
Lock Washer	Brass	Tin-Zinc-Copper-Alloy 100 Over Copper 50
Nut	Brass	Tin-Zinc-Copper-Alloy 100 Over Copper 50
Gasket	Silicone	
Braid Clamp	Brass	Tin-Zinc-Copper-Alloy 100 Over Copper 50
Washer	Brass	Tin-Zinc-Copper-Alloy 100 Over Copper 50
Contact Pin	Phosphor Bronze	Gold 5 Over Nickel 50 Over Copper 50
Insulator	Teflon	
Body	Brass	Tin-Zinc-Copper-Alloy 100 Over Copper 50

Weight:
Suitable Cables: RG5

This part number complies with RoHS.

Notice: JYEBAO reserves the right to make modifications deemed appropriate.

CABLE ASSEMBLY INSTRUCTION

C8205B-0005

JYE BAO CO., LTD.









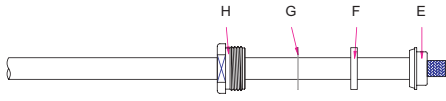
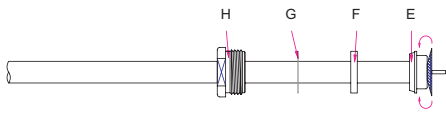
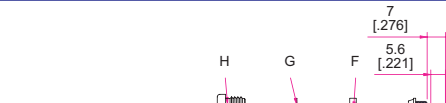
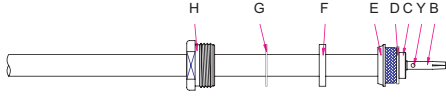
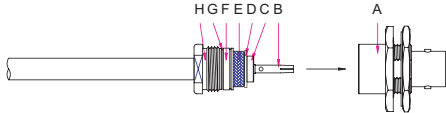
A	B	C	D	E	F	G	H
							
BODY + GASKET + WASHER + HEX NUT	CONTACT PIN	INSULATOR	WASHER	BRAID CLAMP	GASKET	WASHER	NUT

DIAGRAM	ASSEMBLY INSTRUCTION
	Step 1: STRIP AS SHOWN .
	Step 2: SLIDE BRAID CLAMP " E " ,GASKET " F " , WASHER " G " AND NUT " H" OVER CABLE .
	Step 3: WRAP THE BRAIDING OVER " E " .
	Step 4: STRIP AS SHOWN .
	Step 5: SLIDE PREPARED CABLE INTO WASHER " D " AND INSULATOR " C " . Step 6: PUT CONTACT PIN " B " ON CENTER CONDUCTOR AND SOLDER IN " Y " .
	Step 7: FINALLY SCREW " H " ON THE CONNECTOR BODY " A " .

This part number complies with RoHS.

Notice: JYEBAO reserves the right to make modifications deemed appropriate.