

SMB8305-0085

SMB Jack Solder For Bulkhead 50Ω

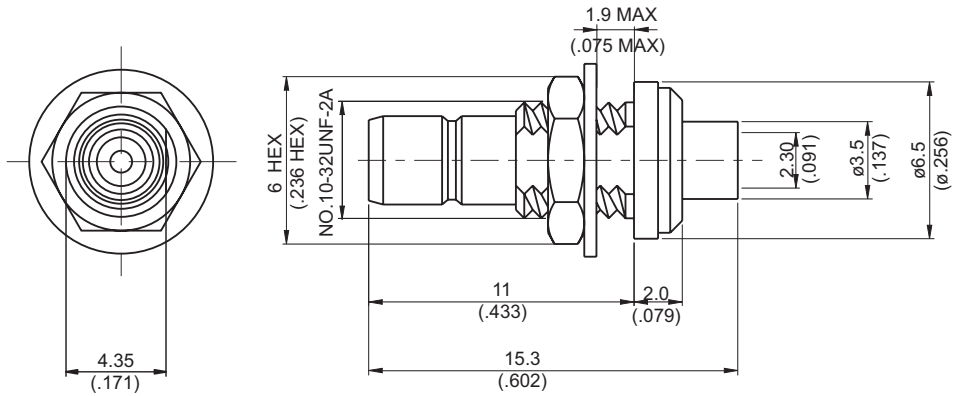

MOUNTING HOLE :

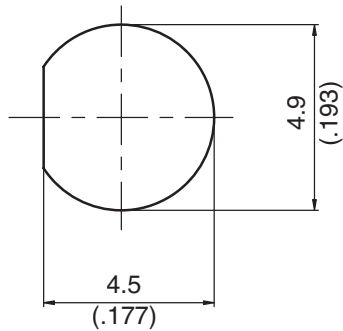

Parts	Material	Plating (Micro-inch)
Hex Nut	Brass	Gold 5 Over Nickel 50 Over Copper 50
Lock Washer	Brass	Gold 5 Over Nickel 50 Over Copper 50
Contact Pin	Brass	Gold 20 Over Nickel 50 Over Copper 50
Insulator	Teflon	
Barrel	Brass	Gold 5 Over Nickel 50 Over Copper 50
Body	Brass	Gold 5 Over Nickel 50 Over Copper 50

Weight: 1.36 g

Suitable Cables: Semi-rigid.085

This part number complies with RoHS.

Notice: JYEBAO reserves the right to make modifications deemed appropriate.

## CABLE ASSEMBLY INSTRUCTION

SMB8305-0085

JYE BAO CO., LTD.

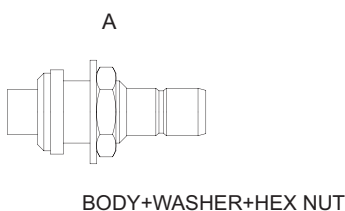
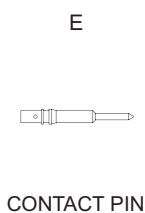

\* TOOLS AND FIXTURES ARE REFERENCE ON  
PAGE 306 OF JYEBAO'S 2005 CATALOG.

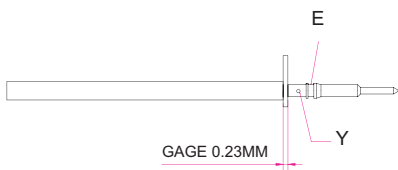
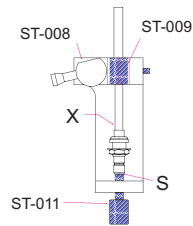
DIAGRAM	ASSEMBLING INSTRUCTION
	<p>Step 1: STRIP AS SHOWN.</p>
	<p>Step 2: PUT 0.23 MM GAGE IN PLACE, INSERT CABLE'S CENTER CONDUCTOR INTO CENTER PIN AND SOLDER IN "Y".</p>
	<p>tep 3: INSERT PREPARED CABLE INTO SOLDERING FIXTURE " ST-008 ". USE INSERT TOOL " ST-009 " AND LOCATOR TOOL " ST-011 " TO FIX THE CONNECTOR . SOLDER IN " X " .</p>

This part number complies with RoHS.

Notice: JYEBAO reserves the right to make modifications deemed appropriate.