

# RM912

## *Power Amplifier Module, 3–4 Volts, for CDMA/AMPS (824–849 MHz)*

The RM912 dual-mode Code Division Multiple Access (CDMA)/Advanced Mobile Phone Service (AMPS) Power Amplifier is a fully matched 6-pin surface mount module designed for mobile units operating in the 824-849 MHz cellular bandwidth. This device meets stringent IS95 CDMA linearity requirements to beyond 28 dBm output power and can be driven to power output levels beyond 31 dBm for high efficiency FM mode operation. A single GaAs Microwave Monolithic Integrated Circuit (MMIC) contains all active circuitry in the module. The MMIC contains on-board bias circuitry, as well as input and interstage matching circuits. The output match is realized off-chip within the module package to optimize efficiency and power performance into a 50  $\Omega$  load. This device is manufactured with Conexant's Gallium Arsenide (GaAs) heterojunction bipolar transistor (HBT) process that provides for all positive voltage DC supply operation while maintaining high efficiency and good linearity. Primary bias to the RM912 can be supplied directly from a three cell nickel-cadmium, single cell lithium-ion, or other suitable battery with an output in the 3-4 volt range. Power down is accomplished by setting the voltage on the low current reference pin to zero volts. No external supply side switch is needed as typical "off" leakage is a few microamperes with full primary voltage supplied from the battery.

### Distinguishing Features

- Low voltage positive bias supply
- Good linearity
- High efficiency
- Dual mode operation
- Large dynamic range
- 6-pin package  
(6 x 6 x 1.5 mm)
- Power down control

### Applications

- Digital cellular (CDMA)
- Analog cellular (AMPS)
- Wireless local loop

### Functional Block Diagram

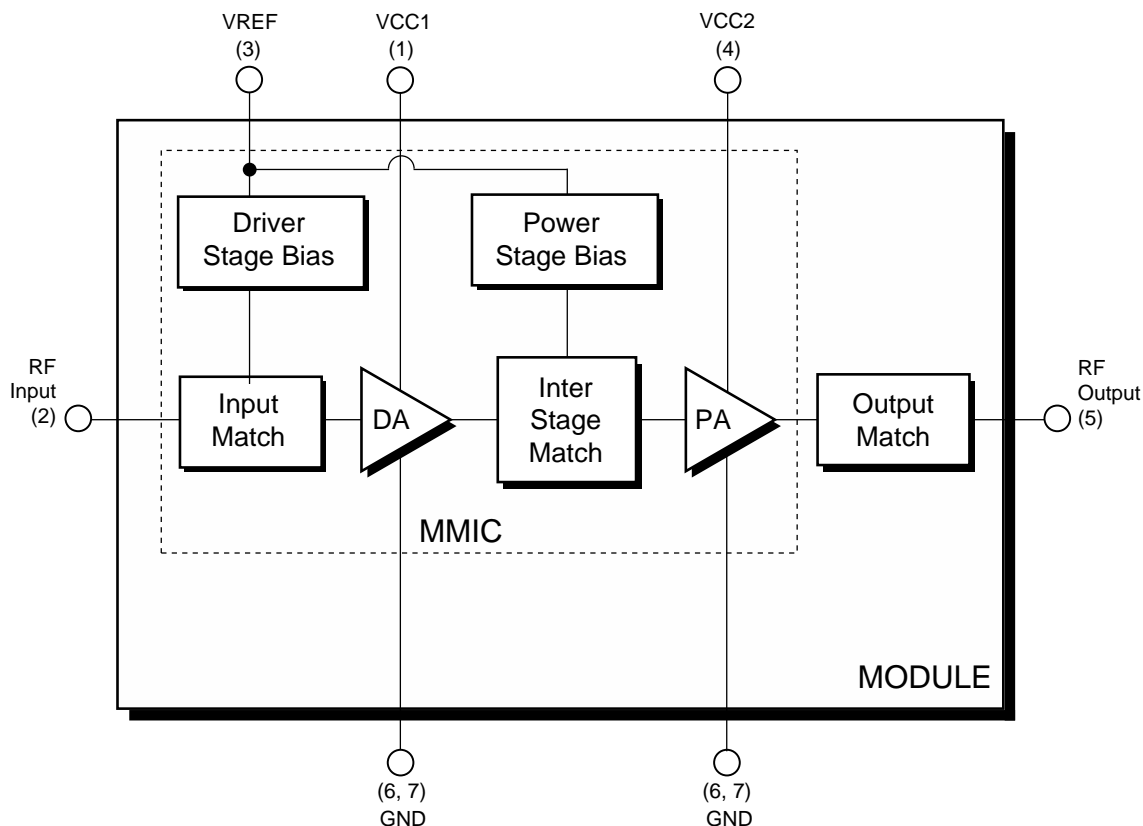

## Electrical Specifications

The following tables list the electrical characteristics of the RM912 Power Amplifier. [Table 1](#) lists the absolute maximum ratings for continuous operation. [Table 2](#) lists the recommended operating conditions for achieving the electrical performance listed in [Table 3](#). [Table 3](#) lists the electrical performance of the RM912 Power Amplifier over the recommended operating conditions.

**Table 1. Absolute Maximum Ratings<sup>(1)</sup>**

Parameter	Symbol	Minimum	Nominal	Maximum	Unit
RF Input Power	Pin	—	3.0	6.0	dBm
Supply Voltage	Vcc	—	3.4	6.0	Volts
Reference Voltage	Vref	—	3.0	3.3	Volts
Case Operating Temperature	Tc	–30	25	+110	°C
Storage Temperature	Tstg	–55	—	+125	°C
<b>NOTE(S):</b> <sup>(1)</sup> No damage assuming only one parameter is set at limit at a time with all other parameters set at or below nominal value.					

**Table 2. Recommended Operating Conditions**

Parameter	Symbol	Minimum	Nominal	Maximum	Unit
Supply Voltage	Vcc	3.2	3.4	4.2	Volts
Reference Voltage	Vref	2.9	3.0	3.1	Volts
Operating Frequency	Fo	824.0	836.5	849.0	MHz
Operating Temperature	To	–30	+25	+85	°C

## Power Amplifier Module, 3–4 Volts, for CDMA/AMPS

Table 3. Electrical Specifications for CDMA / AMPS Nominal Operating Conditions<sup>(1)</sup>

Characteristics	Condition	Symbol	Minimum	Typical	Maximum	Unit
Quiescent current	Vref = 3.0 V	I <sub>q</sub>	—	100.0	—	mA
	Vref = 2.9 V	I <sub>q</sub>	—	80.0	—	mA
Leakage current	Vref = 0 V Vcc = 3.4 V	I <sub>lk</sub>	—	—	4.0	μA
Gain–Digital	Po = 0 dBm	G	26.0	28.0	31.0	dB
	Po = 28 dBm	G <sub>p</sub>	26.0	29.0	32.5	dB
Gain–Analog	Po = 31 dBm	G <sub>p</sub>	26.0	28.0	31.9	dB
Power Added Efficiency	Analog Mode Po = 31 dBm	PAE <sub>a</sub>	42.0	45.0	—	%
	Digital Mode Po = 28 dBm	PAE <sub>d</sub>	31.0	34.0	—	%
Adjacent Channel Power <sup>(2)</sup>	885 kHz Offset Po ≤ 28 dBm	ACP1	—	–50.0	–47.0	dBc
	1980 kHz Offset Po ≤ 28 dBm	ACP2	—	–58.0	–58.0	dBc
Harmonic Suppression	Second Po ≤ 31 dBm	AFo2	—	–42.0	–33.0	dBc
	Third Po ≤ 31 dBm	AFo3	—	–45.0	–35.0	dBc
Noise Power in RX Band 869–894 MHz	Po ≤ 28 dBm	RxBN	—	–134.0	–133.0	dBm/Hz
Noise Figure	—	NF	—	6.0	—	dB
Input Voltage Standing Wave Ratio	—	VSWR	—	1.4:1	1.9:1	—
Stability (Spurious output)	5:1 VSWR All phases	S	—	—	–60.0	dBc
Ruggedness—No damage	Po ≤ 31 dBm	Ru	10:1	—	—	VSWR
<b>NOTE(S):</b>						
<sup>(1)</sup> Vcc = +3.4 V, Vref = +3.0 V, Freq = 836.5 MHz, Tc = 25 °C, unless otherwise specified.						
<sup>(2)</sup> ACP is specified per IS95 as the ratio of the total in-band power (1.23 MHz BW) to adjacent power in a 30 kHz BW.						

Table 4. Electrical Specifications Limits for CDMA / AMPS Recommended Operating Conditions<sup>(1)</sup>

Characteristics	Condition	Symbol	Minimum	Maximum	Unit
Quiescent current	Vref = 3.0 V	Iq	—	140.0	mA
Gain–Digital	Po = 0 dBm	G	25.0	31.5	dB
	Po = 28 dBm	Gp	24.0	34.0	dB
Gain—Analog	Po = 31dBm	Gp	23.0	33.4	dB
Power Added Efficiency	Analog Mode Po = 31 dBm	PAEa	40.0	—	%
	Digital Mode Po = 28 dBm	PAEd	30.0	—	%
Adjacent Channel Power <sup>(2)</sup>	885 kHz Offset Po ≤ 28 dBm	ACP1	—	–44.0	dBc
	1980 kHz Offset Po ≤ 28 dBm	ACP2	—	–56.0	dBc
Harmonic Suppression	Second Po ≤ 31 dBm	AFo2	—	–30.0	dBc
	Third Po ≤ 31 dBm	AFo3	—	–30.0	dBc
Noise Power in RX Band 869—894 MHz	Po ≤ 28 dBm	RxBN	—	–131.0	dBm/Hz
Input Voltage Standing Wave Ratio	—	VSWR	—	2:1	—
<b>NOTE(S):</b> (1) Per <a href="#">Table 2</a> . (2) ACP is specified per IS95 as the ratio of the total in-band power (1.23 MHz BW) to adjacent power in a 30 kHz BW.					

## Characterization Data

The following charts illustrate the characteristics of a typical RM912 Power Amplifier tested in the evaluation board described in the following section. The amplifier was selected by characterizing a group of devices and choosing a part with average electrical performance at both nominal and worst case (limit) conditions. [Figures 1 through 4](#) illustrate the digital signal characteristics and [Figures 5 through 8](#) illustrate the analog characteristics of the RM912

Figure 1. Digital Gain vs. Output Power

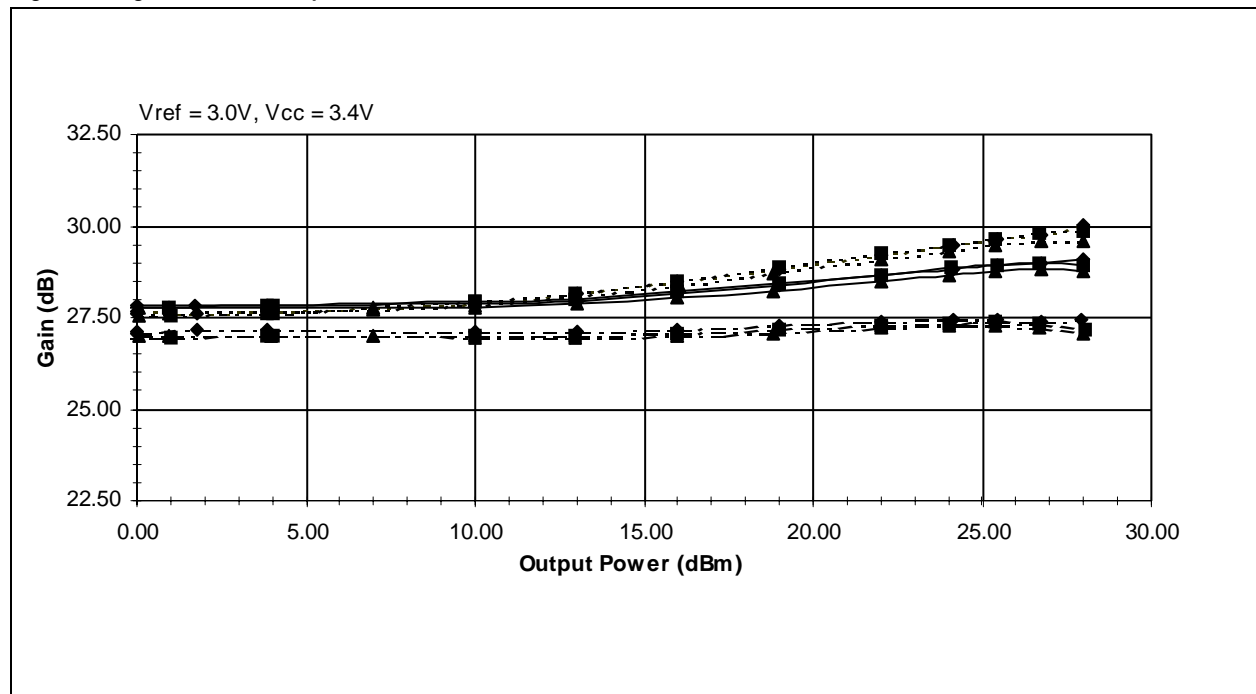

Legend

---◆---	824 MHz @ -30 °C	—◆—	824 MHz @ +25 °C	---◆---	824 MHz @ +85 °C
---■---	837 MHz @ -30 °C	—■—	837 MHz @ +25 °C	---■---	837 MHz @ +85 °C
---▲---	849 MHz @ -30 °C	—▲—	849 MHz @ +25 °C	---▲---	849 MHz @ +85 °C

Figure 2. Digital Adjacent Channel Power (ACP1) vs. Output Power

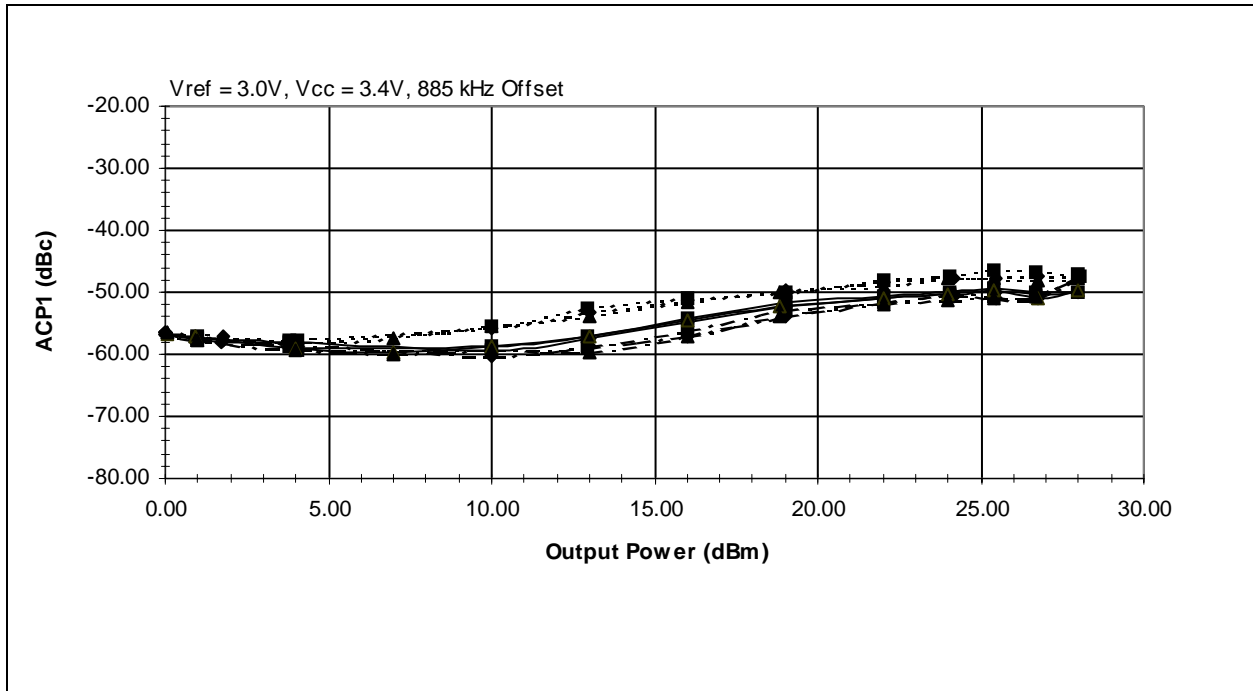
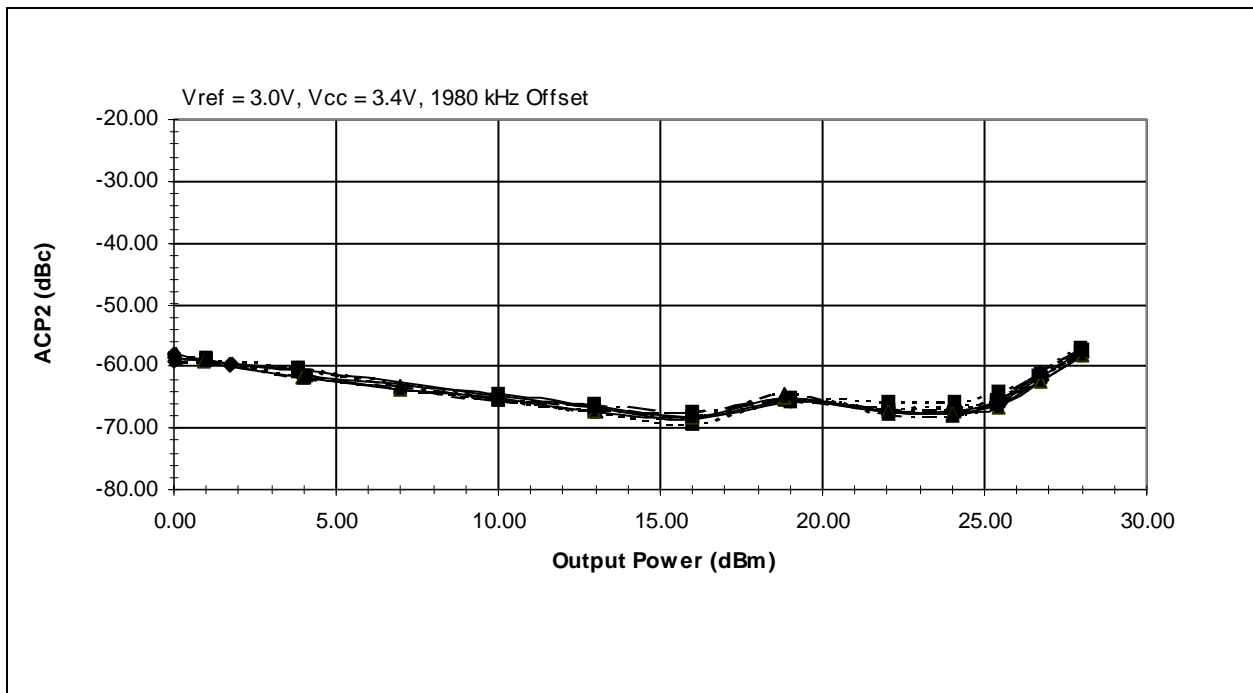

Figure 3. Digital Adjacent Channel Power (ACP2) vs. Output Power



Legend

---◆---	824 MHz @ -30 °C	—◆—	824 MHz @ +25 °C	---◆---	824 MHz @ +85 °C
---■---	837 MHz @ -30 °C	—■—	837 MHz @ +25 °C	---■---	837 MHz @ +85 °C
---▲---	849 MHz @ -30 °C	—▲—	849 MHz @ +25 °C	---▲---	849 MHz @ +85 °C

Power Amplifier Module, 3–4 Volts, for CDMA/AMPS

Figure 4. Digital Power Added Efficiency vs. Output Power

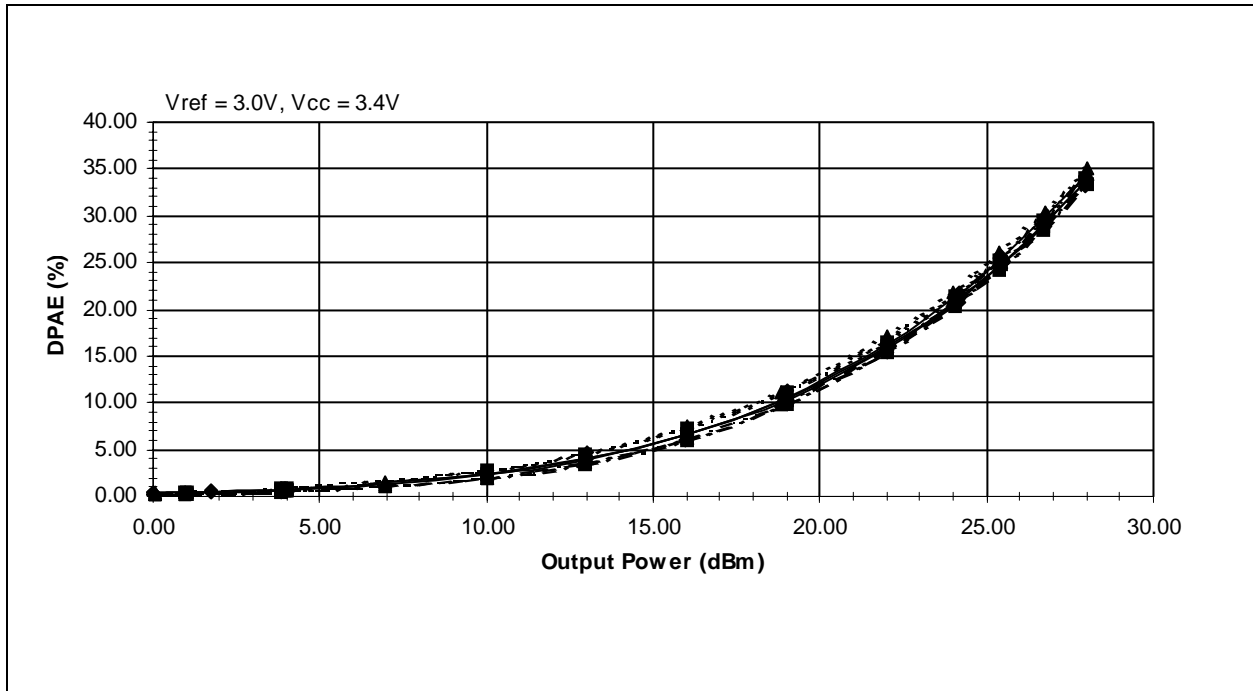
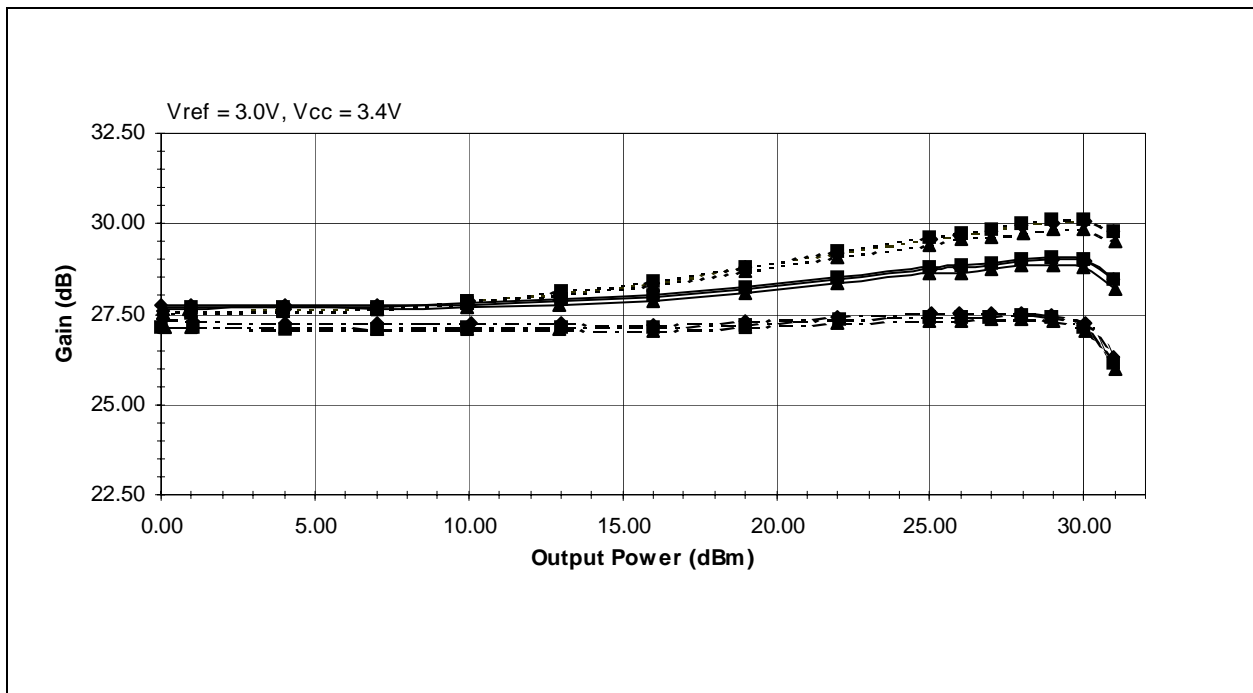

Figure 5. Analog Gain vs. Output Power



Legend

---◆---	824 MHz @ -30 °C	—◆—	824 MHz @ +25 °C	---◆--	824 MHz @ +85 °C
---■---	837 MHz @ -30 °C	—■—	837 MHz @ +25 °C	---■--	837 MHz @ +85 °C
---▲---	849 MHz @ -30 °C	—▲—	849 MHz @ +25 °C	---▲--	849 MHz @ +85 °C

Figure 6. Analog Power Added Efficiency vs. Output Power

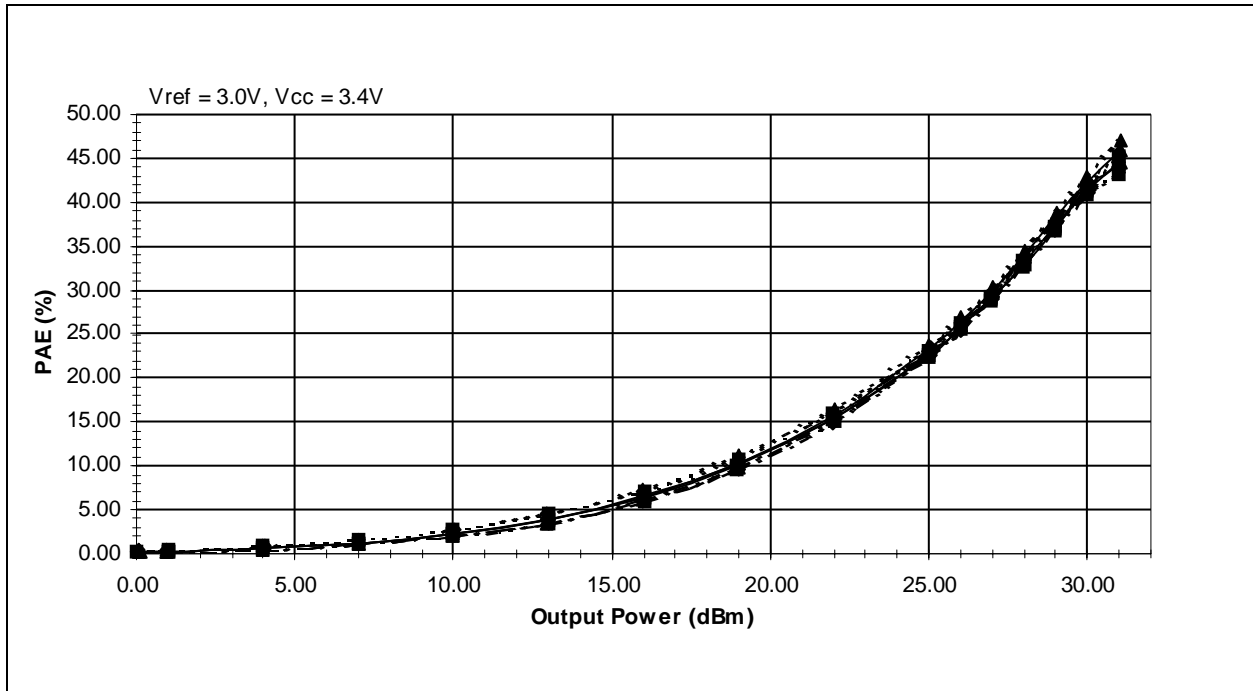
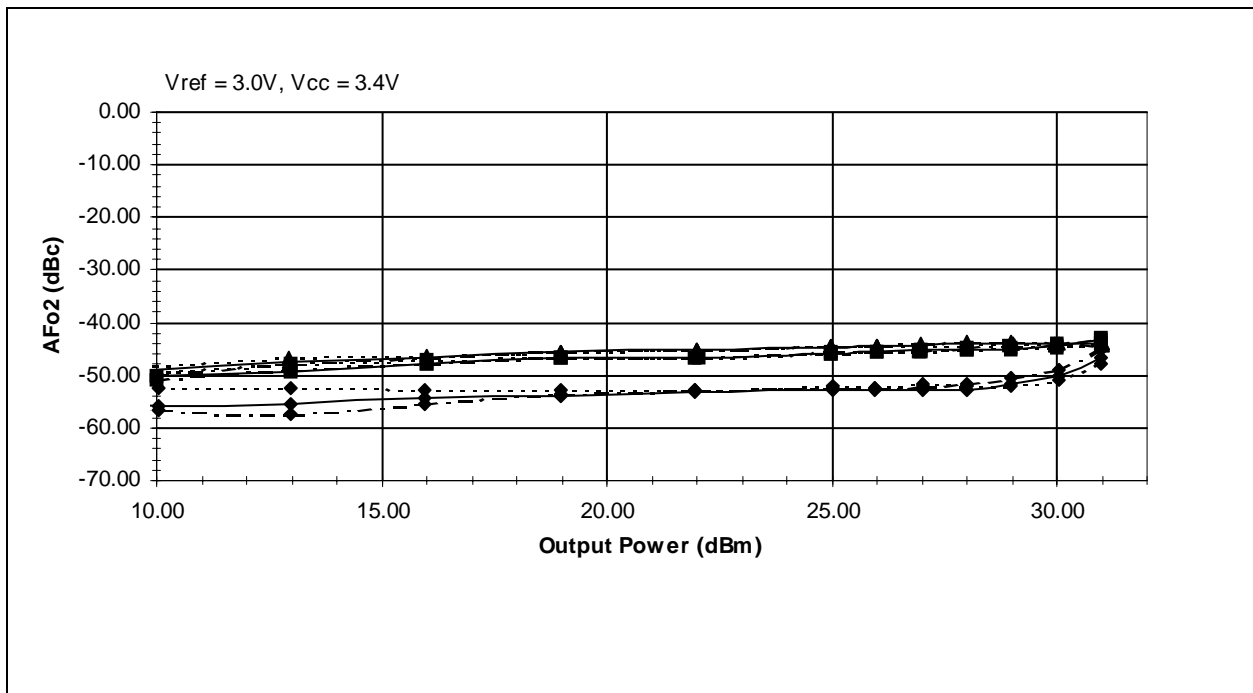

Figure 7. Analog Second Order Harmonic Suppression



Legend

---◆---	824 MHz @ -30 °C	—◆—	824 MHz @ +25 °C	---◆---	824 MHz @ +85 °C
---■---	837 MHz @ -30 °C	—■—	837 MHz @ +25 °C	---■---	837 MHz @ +85 °C
---▲---	849 MHz @ -30 °C	—▲—	849 MHz @ +25 °C	---▲---	849 MHz @ +85 °C

Power Amplifier Module, 3–4 Volts, for CDMA/AMPS

Figure 8. Analog Third Order Harmonic Suppression

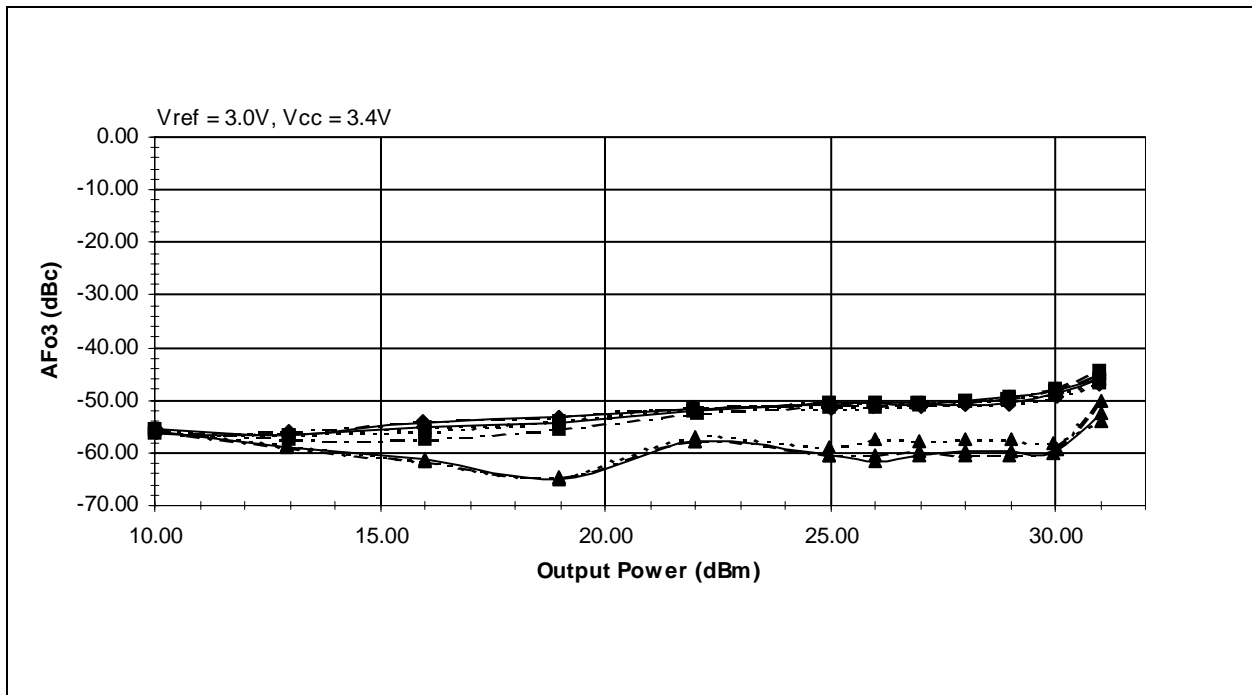

Legend

---◆---	824 MHz @ -30 °C	—◆—	824 MHz @ +25 °C	---◆---	824 MHz @ +85 °C
---■---	837 MHz @ -30 °C	—■—	837 MHz @ +25 °C	---■---	837 MHz @ +85 °C
---▲---	849 MHz @ -30 °C	—▲—	849 MHz @ +25 °C	---▲---	849 MHz @ +85 °C

Figure 9. Digital Gain vs. Output Power

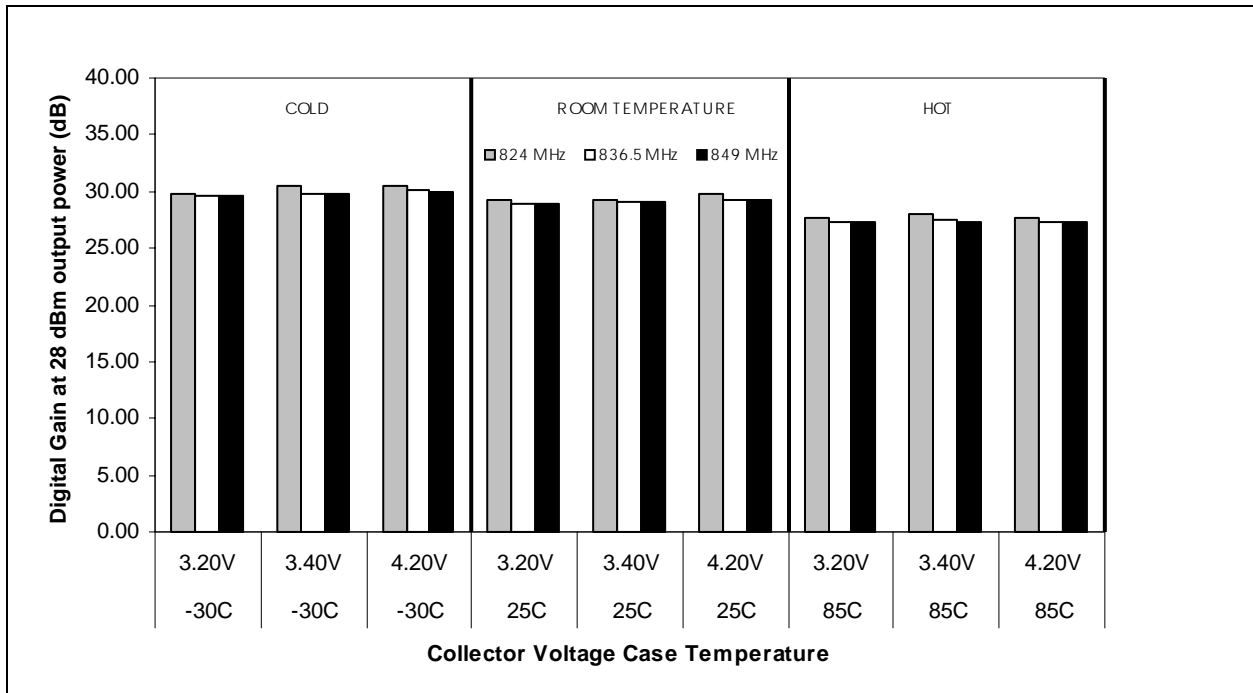
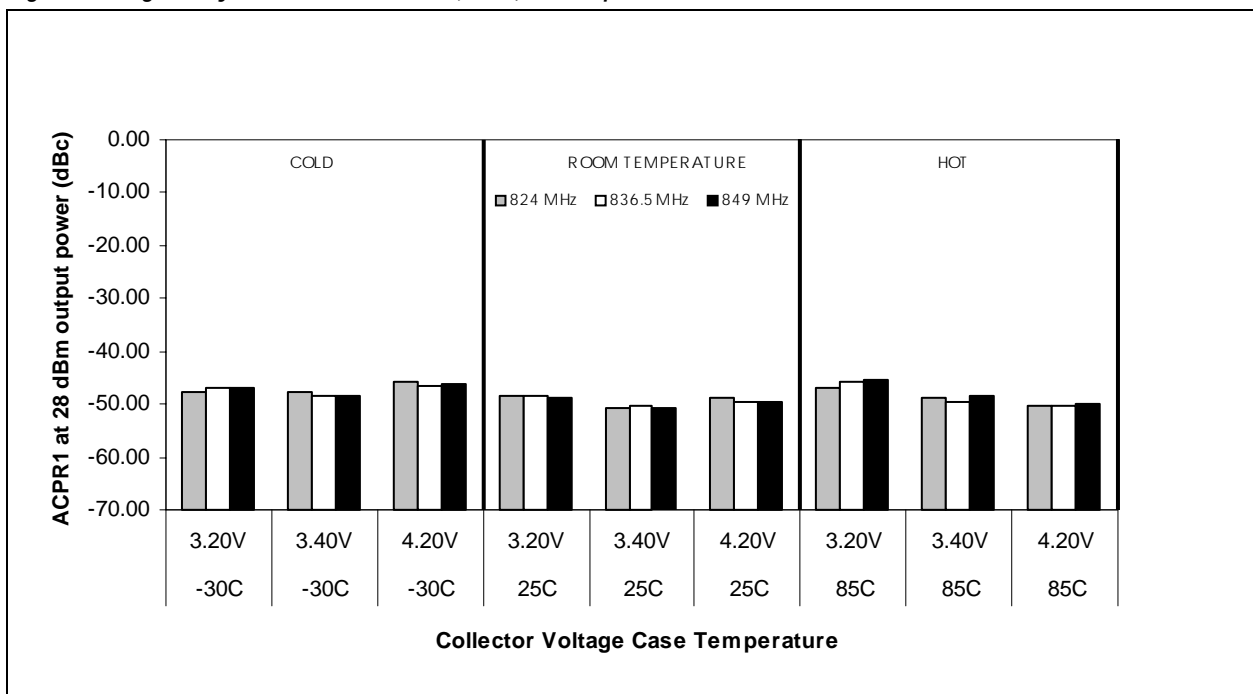

Figure 10. Digital Adjacent Channel Power (ACP1) vs. Output Power



Power Amplifier Module, 3–4 Volts, for CDMA/AMPS

Figure 11. Digital Adjacent Channel Power (ACP2) vs. Output Power

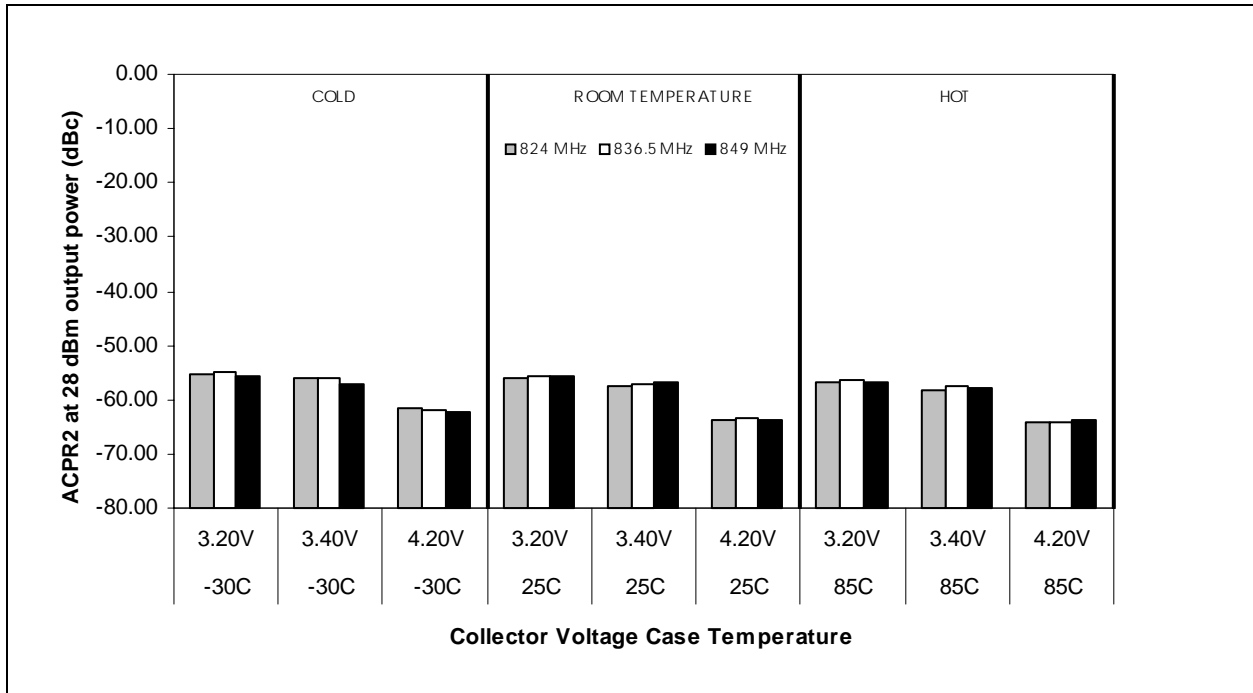

Figure 12. Analog Gain vs. Output Power

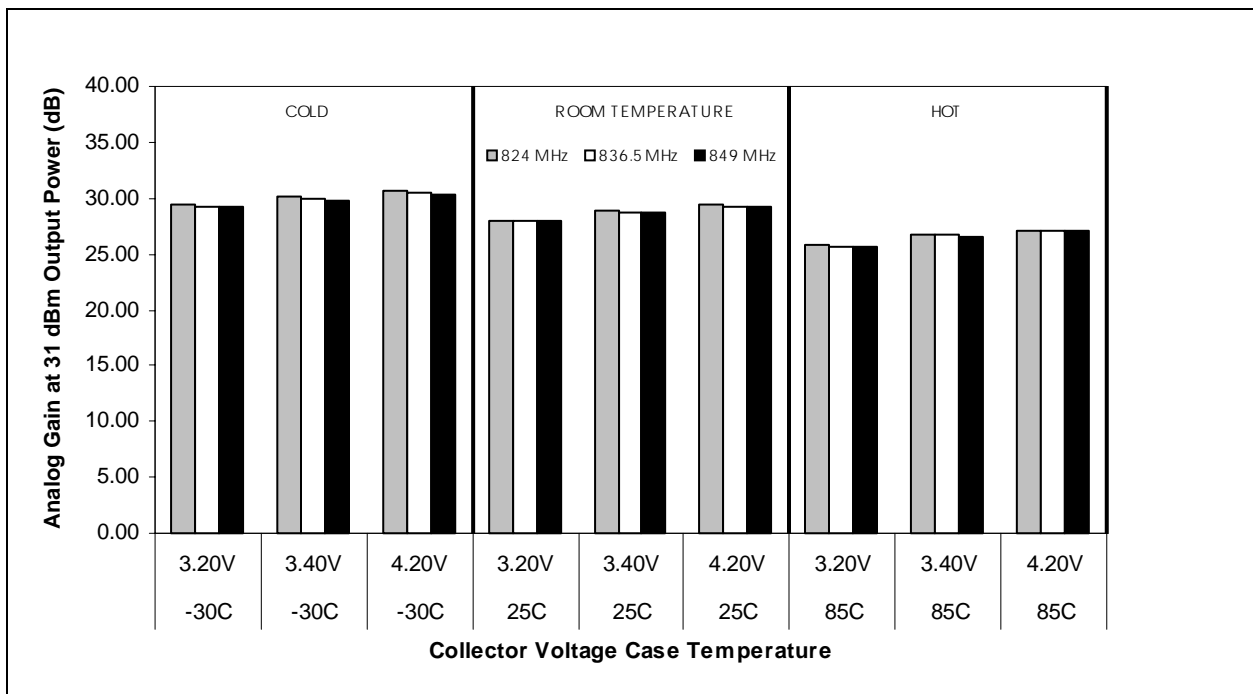

Figure 13. Analog Second Order Harmonic Suppression

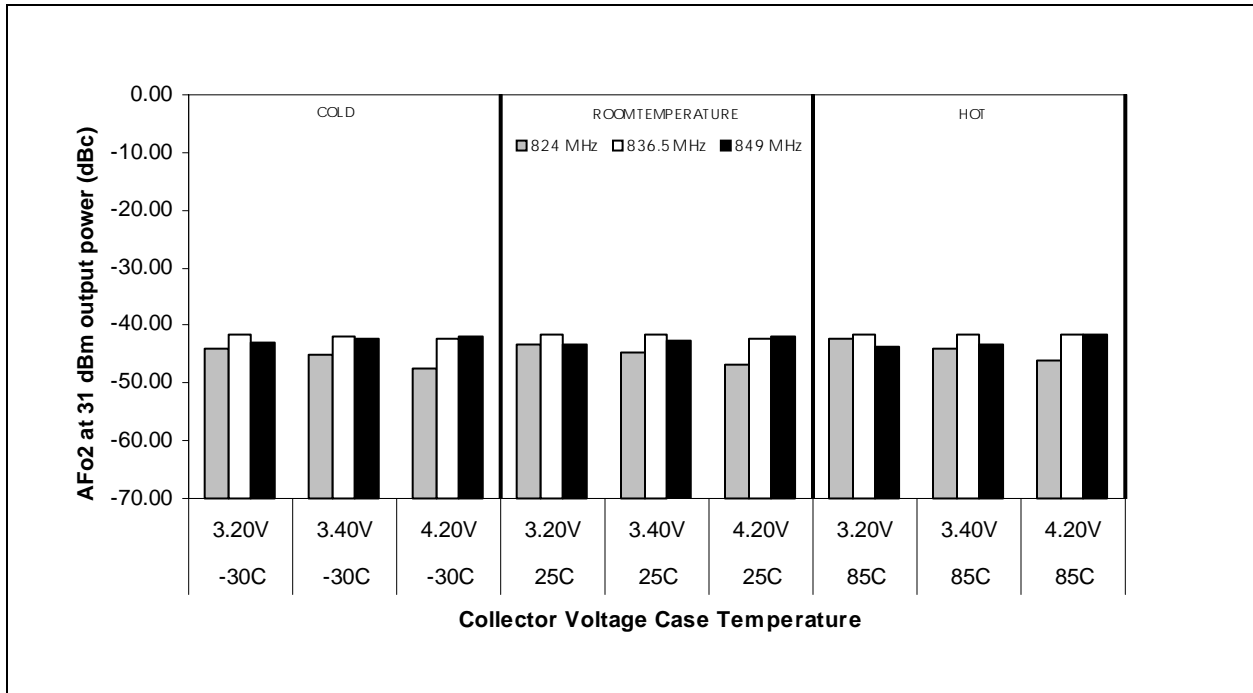
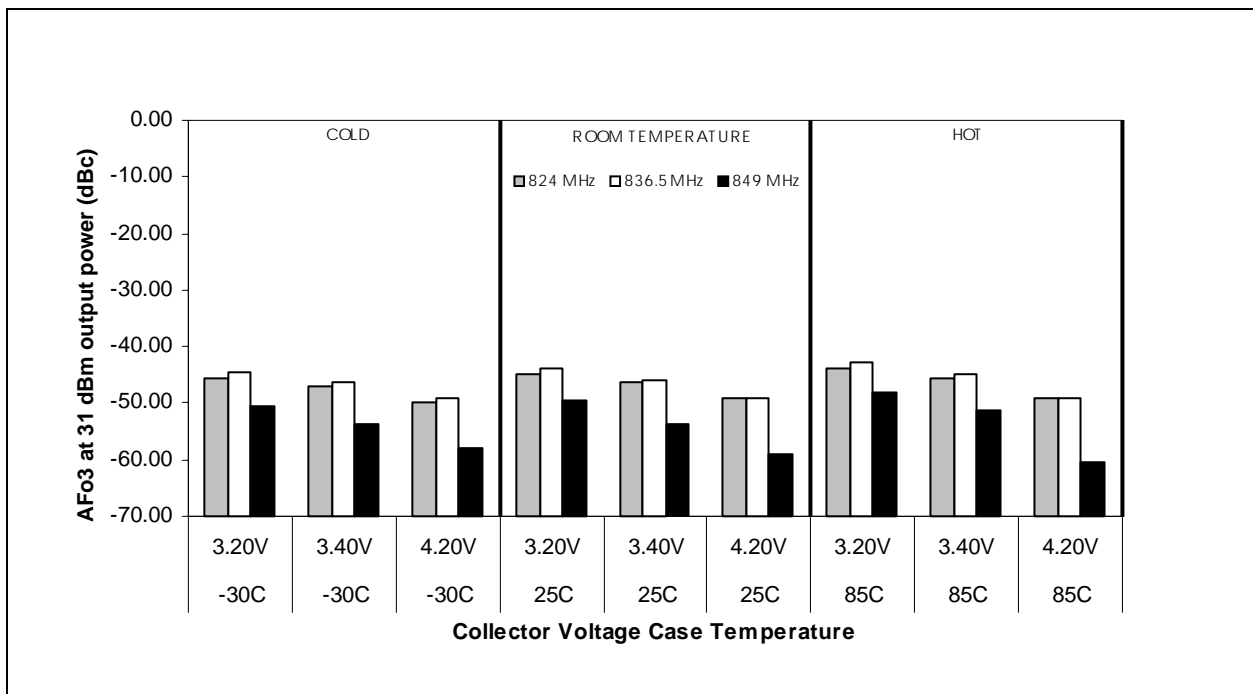

Figure 14. Analog Third Order Harmonic Suppression



Power Amplifier Module, 3–4 Volts, for CDMA/AMPS

Figure 15. Noise Figure Variation Over Recommended Operating Conditions

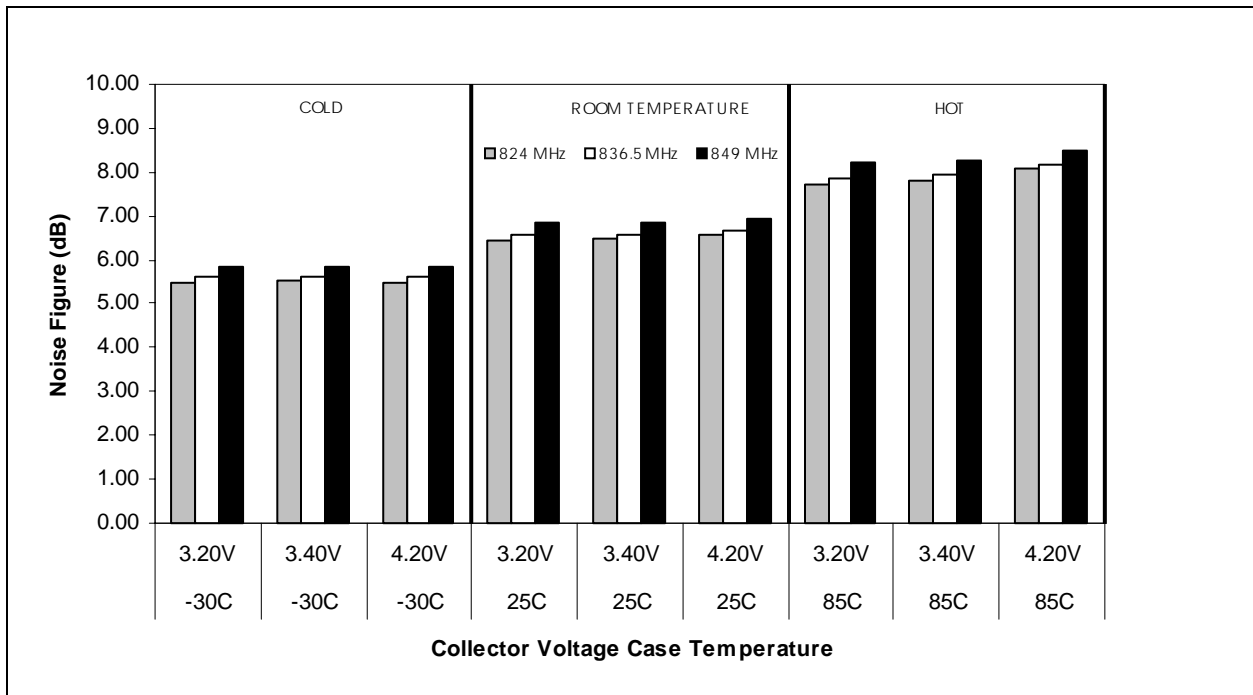
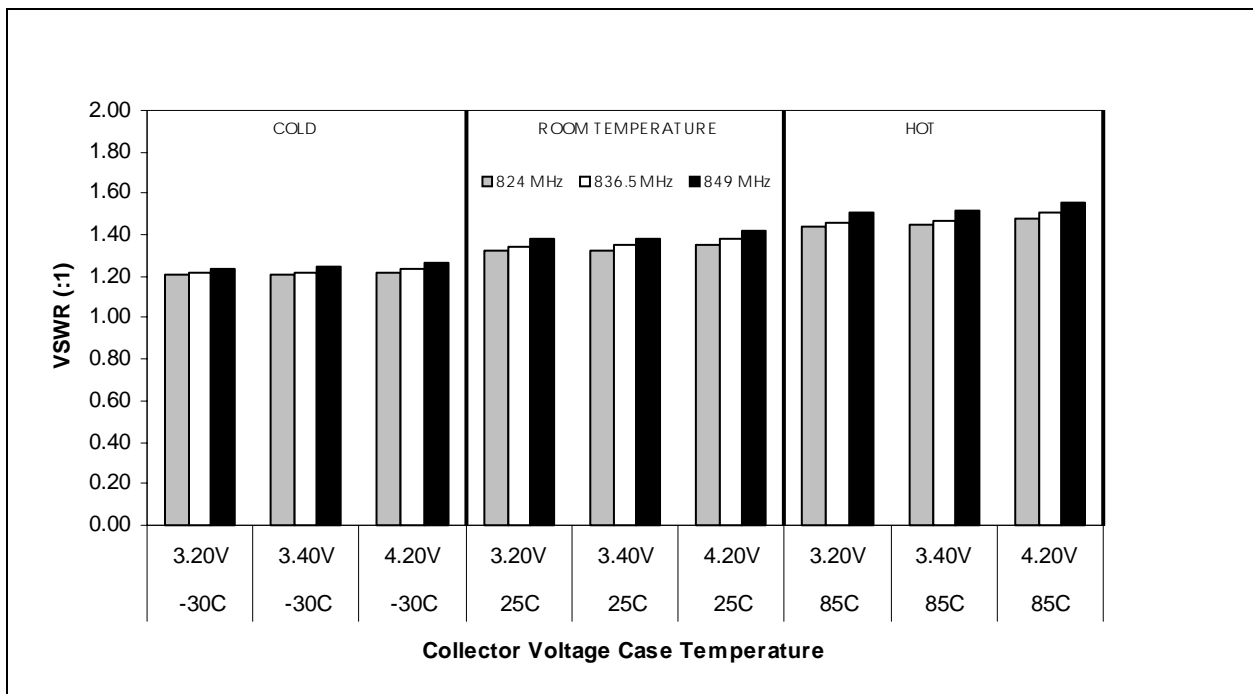

Figure 16. Voltage Standing Wave Ratio Variation Over Recommended Operating Conditions



## Evaluation Board Description

The evaluation board is a platform for testing and interfacing design circuitry. To accommodate the interface testing of the RM912, the evaluation board schematic and diagrams are included for preliminary analysis and design. Figure 17 shows the basic schematic of the board for the 824 MHz to 849 MHz range. Figure 18 illustrates the board layout.

Figure 17. Evaluation Board Schematic

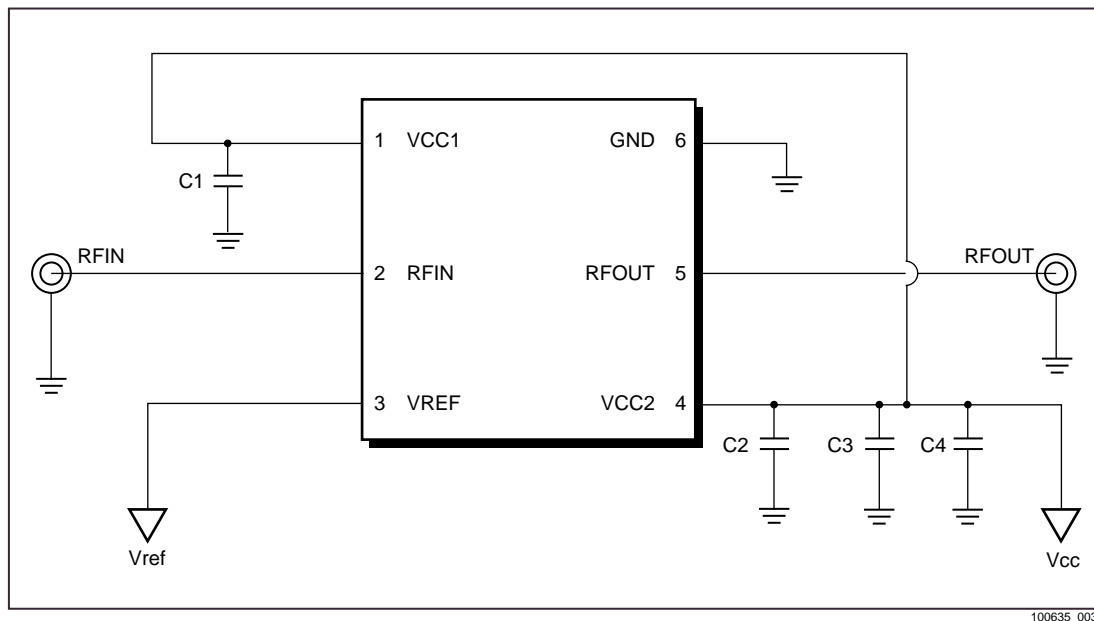
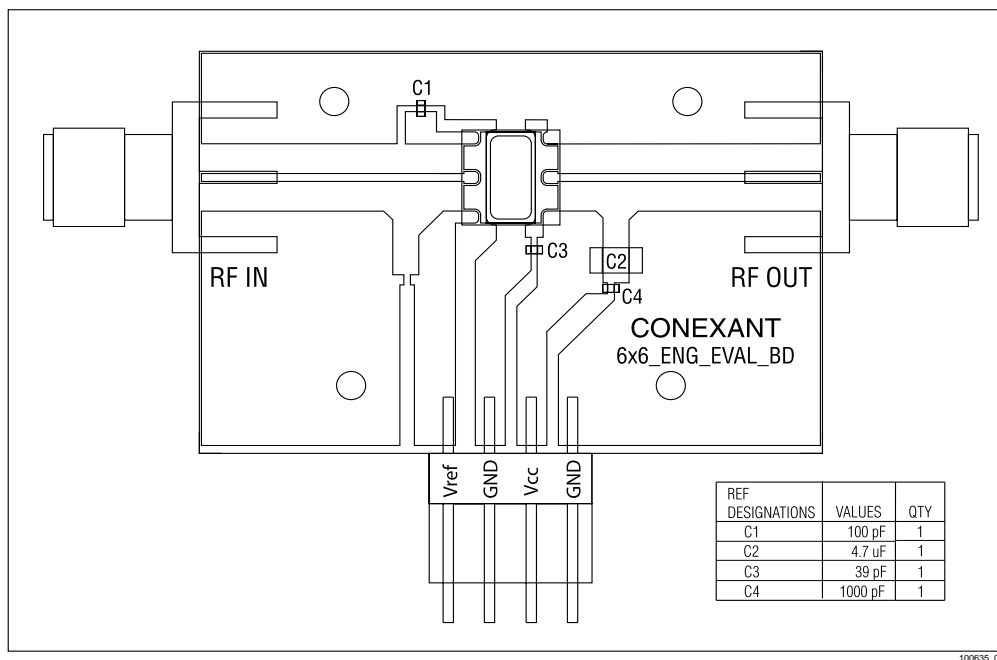

Figure 18. Evaluation Board Assembly Diagram



## Package Dimensions and Pin Descriptions

The RM912 is a multi-layer laminate base, overmold encapsulated modular package designed for surface mount solder attachment to a printed circuit board.

Figure 19. RM912 Package Drawing

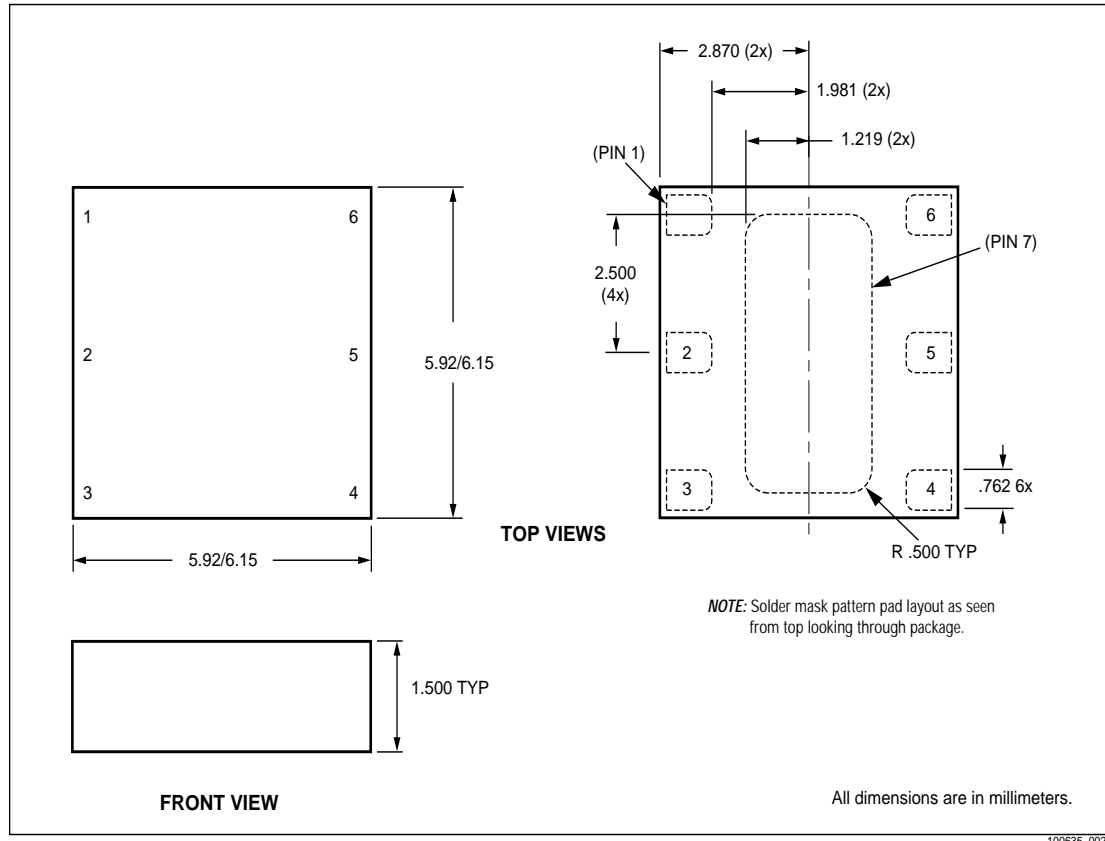

Table 5. Pin Description

Pin #	Function
1	VCC1 <sup>(1)</sup>
2	RF Input
3	VREF
4	VCC2 <sup>(1)</sup>
5	RF Output
6	GND
GND PAD	GND <sup>(2)</sup>

**NOTE(S):**  
<sup>(1)</sup> All supply pins may be connected together at the supply.  
<sup>(2)</sup> Package underside is GND.

## Package and Handling Information

Because this device package is sensitive to moisture absorption, it is baked and vacuum packed prior to shipment. Instructions on the shipping container label regarding exposure to moisture after the container seal is broken must be followed. Otherwise, problems related to moisture absorption may occur when the part is subjected to high temperature during solder assembly. If the part is attached in a reflow oven, the temperature ramp rate should not exceed 5 °C per second. Maximum temperature should not exceed 225 °C and the time spent at a temperature exceeding 210 °C should be limited to less than 10 seconds. If the part is manually attached, precaution should be taken to insure that the part is not subjected to a temperature exceeding 300 °C for more than 10 seconds.

Care must be taken when attaching this product, whether it is done manually or in a production solder reflow environment. For additional details on both attachment techniques, precautions, and handling procedures recommended by Conexant, please refer to *Application Note: Solder Reflow, Document Number 101536*.

Production quantities of this product are shipped in the standard tape-and-reel format. For packaging details, refer to *Application Note: Tape and Reel, Document Number 101568*.

*Figure 20. Typical Case Markings*

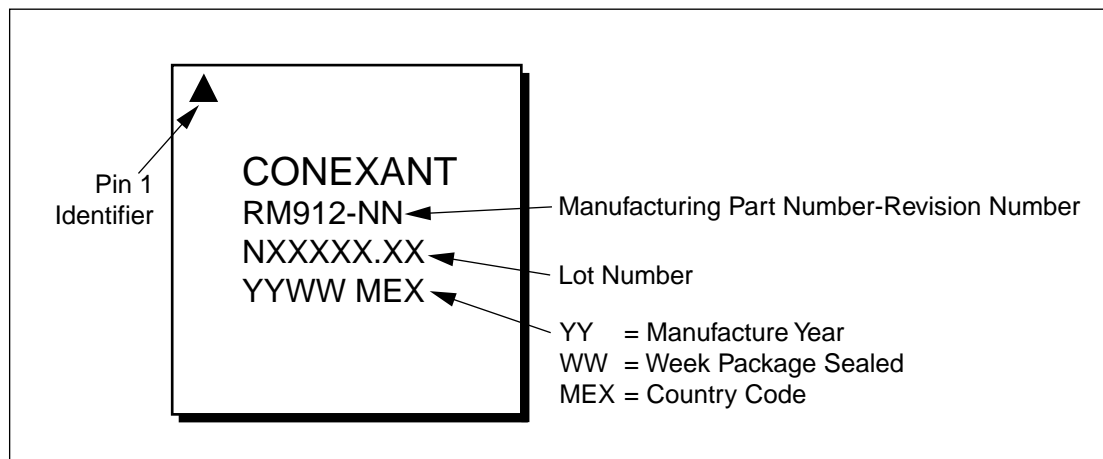

## Electrostatic Discharge Sensitivity

The RM912 is a Class I device. [Figure 21](#) lists the Electrostatic Discharge (ESD) immunity level for each pin of the RM912 product. The numbers in [Figure 21](#) specify the ESD threshold level for each pin where the I-V curve between the pin and ground starts to show degradation. The ESD testing was performed in compliance with MIL-STD-883E Method 3015.7 using the Human Body Model. Since 2000 volts represents the maximum measurement limit of the test equipment used, pins marked > 2000 V pass 2000V ESD stress.

**Figure 21. ESD Sensitivity Areas**

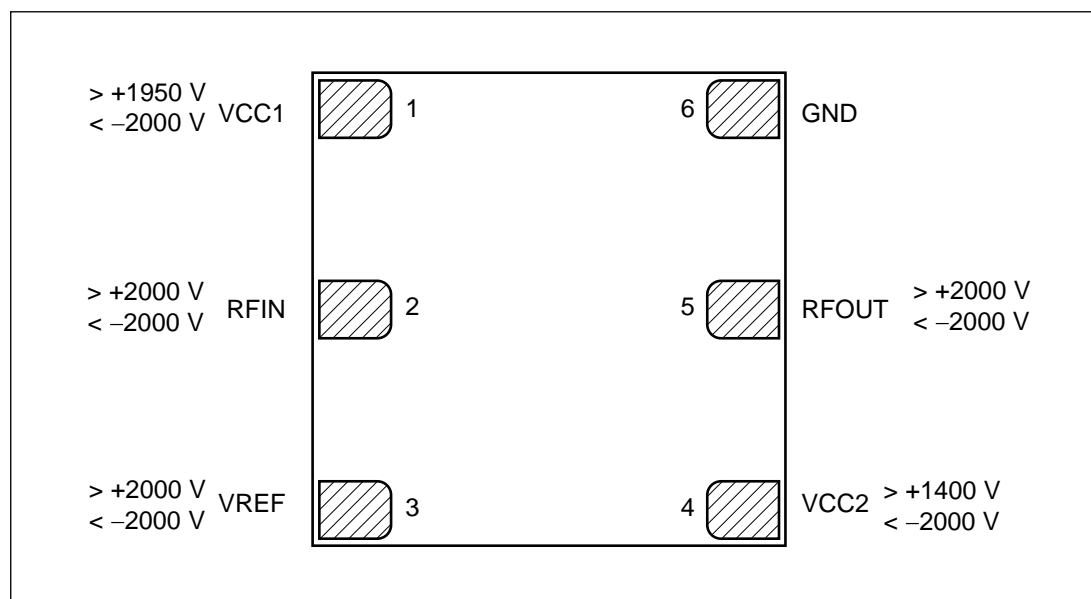

100635\_007

Various failure criteria can be utilized when performing ESD testing. Many vendors employ relaxed ESD failure standards which fail devices only after “the pin fails the electrical specification limits” or “the pin becomes completely non-functional”. Conexant employs most stringent criteria, fails devices as soon as the pin begins to show any degradation on a curve tracer.

To avoid ESD damage, latent or visible, it is very important the Class-1 ESD handling precautions listed in [Table 6](#) be used in the product assembly and test areas follow.

**Table 6. Precautions for GaAs ICs with ESD Thresholds Greater Than 200V But Less Than 2000V**

<p style="text-align: center;"><b><u>Personnel Grounding</u></b></p> <p>Wrist Straps Conductive Smocks, Gloves and Finger Cots Antistatic ID Badges</p>	<p style="text-align: center;"><b><u>Facility</u></b></p> <p>Relative Humidity Control and Air Ionizers Dissipative Floors (less than 10<sup>9</sup> Ω to GND)</p>
<p style="text-align: center;"><b><u>Protective Workstation</u></b></p> <p>Dissipative Table Tops Protective Test Equipment (Properly Grounded) Grounded Tip Soldering Irons Conductive Solder Suckers Static Sensors</p>	<p style="text-align: center;"><b><u>Protective Packaging &amp; Transportation</u></b></p> <p>Bags and Pouches (Faraday Shield) Protective Tote Boxes (Conductive Static Shielding) Protective Trays Grounded Carts Protective Work Order Holders</p>



## Ordering Information

Model Number	Manufacturing Part Number	Product Revision	Package	Operating Temperature
RM912	RM912-15	15	6x6LM-6	-30 °C to +85 °C

## Revision History

Revision	Level	Date	Description
A		March 2000	Preliminary Information
B		March 2000	Updated Preliminary Information
C		June 2000	Added Characterization Data, Released
D		July 2000	Updated ESD Data
E		July 2000	Preprint Update
F		August 2000	Web Site Update
G		August 2000	Web Format Corrections
H		December 2000	Add: Solder Reflow, Temp. Guidelines; Revise: Figure 21; Revise Ordering Information
I		March 2001	Revise: Table 3, graphs
J		October 2001	Revise: Tables 3, 4; Figures 18, 20, 21

## References:

1. Application Note: Solder Reflow, Document Number 101536
2. Application Note: Tape and Reel, Document Number 101568

© 2001, Conexant Systems, Inc.  
All Rights Reserved.

Information in this document is provided in connection with Conexant Systems, Inc. ("Conexant") products. These materials are provided by Conexant as a service to its customers and may be used for informational purposes only. Conexant assumes no responsibility for errors or omissions in these materials. Conexant may make changes to specifications and product descriptions at any time, without notice. Conexant makes no commitment to update the information and shall have no responsibility whatsoever for conflicts or incompatibilities arising from future changes to its specifications and product descriptions.

No license, express or implied, by estoppel or otherwise, to any intellectual property rights is granted by this document. Except as provided in Conexant's Terms and Conditions of Sale for such products, Conexant assumes no liability whatsoever.

THESE MATERIALS ARE PROVIDED "AS IS" WITHOUT WARRANTY OF ANY KIND, EITHER EXPRESS OR IMPLIED, RELATING TO SALE AND/OR USE OF CONEXANT PRODUCTS INCLUDING LIABILITY OR WARRANTIES RELATING TO FITNESS FOR A PARTICULAR PURPOSE, CONSEQUENTIAL OR INCIDENTAL DAMAGES, MERCHANTABILITY, OR INFRINGEMENT OF ANY PATENT, COPYRIGHT OR OTHER INTELLECTUAL PROPERTY RIGHT. CONEXANT FURTHER DOES NOT WARRANT THE ACCURACY OR COMPLETENESS OF THE INFORMATION, TEXT, GRAPHICS OR OTHER ITEMS CONTAINED WITHIN THESE MATERIALS. CONEXANT SHALL NOT BE LIABLE FOR ANY SPECIAL, INDIRECT, INCIDENTAL, OR CONSEQUENTIAL DAMAGES, INCLUDING WITHOUT LIMITATION, LOST REVENUES OR LOST PROFITS, WHICH MAY RESULT FROM THE USE OF THESE MATERIALS.

Conexant products are not intended for use in medical, lifesaving or life sustaining applications. Conexant customers using or selling Conexant products for use in such applications do so at their own risk and agree to fully indemnify Conexant for any damages resulting from such improper use or sale.

The following are trademarks of Conexant Systems, Inc.: Conexant™, the Conexant C symbol, and "What's Next in Communications Technologies"™. Product names or services listed in this publication are for identification purposes only, and may be trademarks of third parties. Third-party brands and names are the property of their respective owners.

For additional disclaimer information, please consult Conexant's Legal Information posted at [www.conexant.com](http://www.conexant.com), which is incorporated by reference.

**Reader Response:** Conexant strives to produce quality documentation and welcomes your feedback. Please send comments and suggestions to [tech.pubs@conexant.com](mailto:tech.pubs@conexant.com). For technical questions, contact your local Conexant sales office or field applications engineer.

[www.conexant.com](http://www.conexant.com)

General Information:

U.S. and Canada: (800) 854-8099

International: (949) 483-6996

Headquarters – Newport Beach

4311 Jamboree Rd.

Newport Beach, CA. 92660-3007

