



# 21150 PCI-to-PCI Bridge

## Brief Datasheet

### Product Features

Intel's 21150 is a PCI-to-PCI bridge that is fully compliant with *PCI Local Bus Specification*, Revision 2.1, and the *Advanced Configuration Power Interface (ACPI) Specification*. The 21150 provides full support for delayed transactions, which enables the buffering of memory read, I/O, and configuration transactions.

- Complies fully with Revision 2.1 of the *PCI Local Bus Specification*
- Complies fully with the *PCI Bus Power Management Specification*
- Complies fully with the *Advanced Configuration Power Interface (ACPI) Specification*
- Allows 72 bytes of read data buffering in each direction
- Includes live insertion support
- Provides ten secondary clock outputs:
  - Low skew, permitting direct drive of option slots
  - Individual clock disables, capable of automatic configuration during reset
- Supports both 5-V and 3.3-V signaling environments
- Allows 88 bytes of buffering (data and address) for posted memory write commands in each direction—up to 5 posted write transactions simultaneously in each direction
- Provides enhanced address decoding:
  - A 32-bit I/O address range
  - A 32-bit memory-mapped I/O address range
  - A 64-bit prefetchable memory address range
  - ISA-aware mode for legacy support in the first 64 KB of I/O address range
- Provides VGA addressing and VGA palette snooping support
- Provides concurrent primary and secondary bus operation to isolate traffic
- Provides a 4-pin general-purpose I/O interface, accessible through device-specific configuration space
- Available in both 33 MHz and 66 MHz versions
- Includes downstream lock support
- Provides arbitration support for nine secondary bus devices:
  - A programmable 2-level arbiter
  - Hardware disable control, permitting use of an external arbiter
- Provides an IEEE standard 1149.1 JTAG interface
- Implements delayed transactions for all PCI configuration, I/O, and memory read commands—up to three transactions simultaneously in each direction
- Supports PCI transaction forwarding for the following commands:
  - All I/O and memory commands
  - Type 1 to Type 1 configuration commands
  - Type 1 to Type 0 configuration commands (downstream only)
  - All Type 1 to special cycle configuration commands



## Description

The 21150 has separate posted write, read data, and delayed transaction queues with significant buffering capability. In addition, the 21150 supports buffering of simultaneous, multiple, posted write and delayed transactions in both directions.

Among the features of the 21150 are:

- A programmable 2-level secondary bus arbiter
- An IEEE standard 1149.1 JTAG interface
- Live insertion support
- A 4-pin general-purpose I/O interface
- Individual secondary clock disables
- Enhanced address decoding

The 21150 has sufficient clock and arbitration pins to support nine PCI bus master devices directly on its secondary interface.

The 21150 allows the two PCI buses to operate concurrently. This means that a master and a target on the same PCI bus can communicate while the other PCI bus is busy. This traffic isolation may increase system performance in applications such as multimedia.

Information in this document is provided in connection with Intel products. No license, express or implied, by estoppel or otherwise, to any intellectual property rights is granted by this document. Except as provided in Intel's Terms and Conditions of Sale for such products, Intel assumes no liability whatsoever, and Intel disclaims any express or implied warranty, relating to sale and/or use of Intel products including liability or warranties relating to fitness for a particular purpose, merchantability, or infringement of any patent, copyright or other intellectual property right. Intel products are not intended for use in medical, life saving, or life sustaining applications.

Intel may make changes to specifications and product descriptions at any time, without notice.

Contact your local Intel sales office or your distributor to obtain the latest specifications and before placing your product order.

Copies of documents which have an ordering number and are referenced in this document, or other Intel literature may be obtained by calling 1-800-548-4725 or by visiting Intel's website at <http://www.intel.com>.

Copyright © Intel Corporation, 1998

\*Third-party brands and names are the property of their respective owners.

## Applications

The 21150 makes it possible to extend a system's load capability limit beyond that of a single PCI bus by allowing motherboard designers to add more PCI devices, or more PCI option card slots, than a single PCI bus can support. Figure 1, the system card block diagram illustrates the use of two PCI-to-PCI bridges on a system board. Each 21150 added to the board creates a new PCI bus that provides support for the additional PCI slots or devices.

Figure 1. System Card Block Diagram

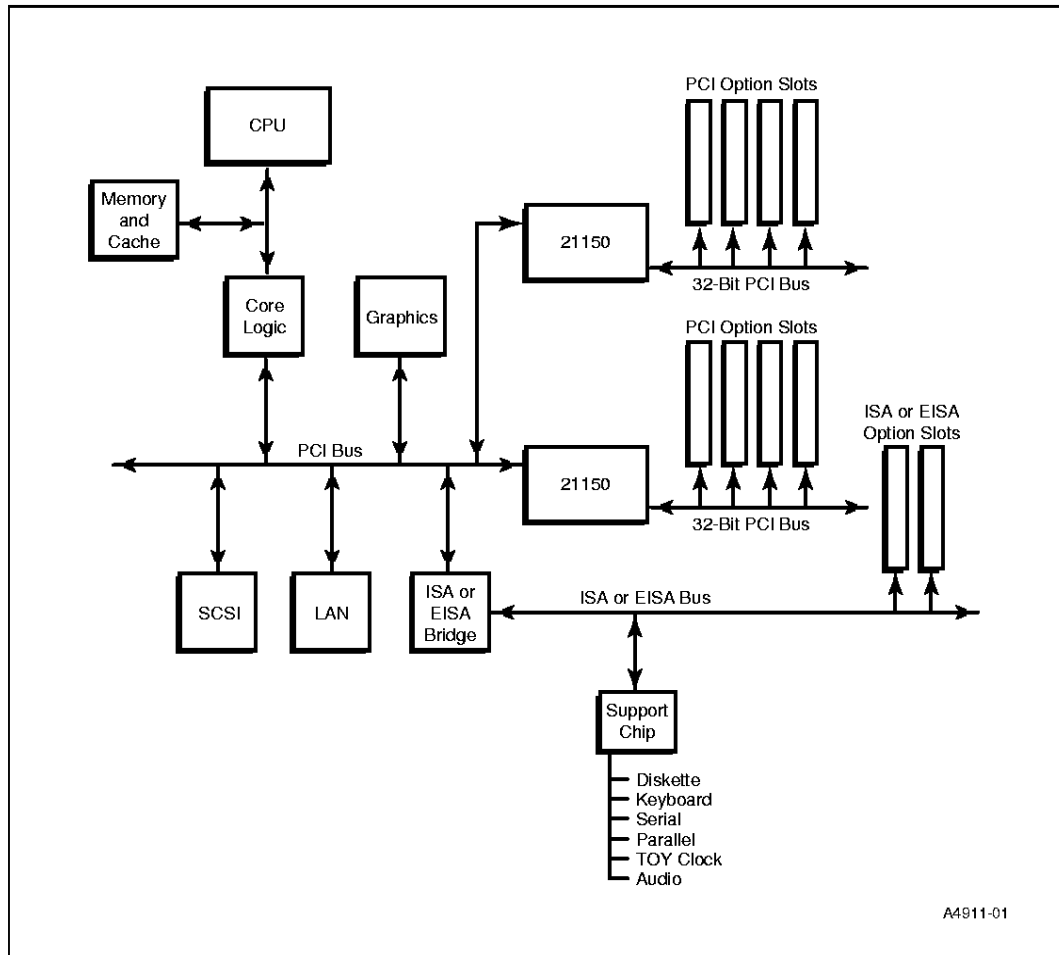

A4911-01

## Multidevice PCI Option Cards

Option card designers can use the 21150 to implement multiple-device PCI option cards. Without a PCI-to-PCI bridge, PCI loading rules would limit option cards to one device. The *PCI Local Bus Specification* loading rules limit PCI option cards to a single connection per PCI signal in the option card connector. However, the 21150 overcomes this restriction by providing, on the option card, an independent PCI bus to which up to nine devices can be attached. Figure 2, the 21150 with option cards diagram illustrates how the 21150 enables the design of a multicomponent option card.

Figure 2. 21150 with Option Cards

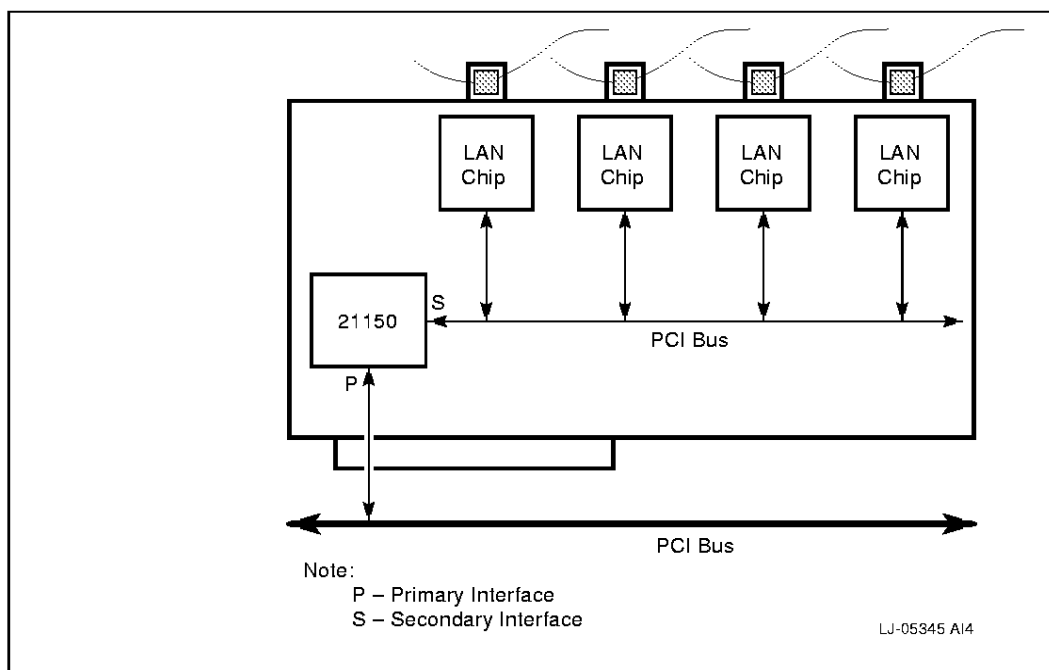

Characteristics	Specifications
Power supply	Vdd 3.3 V Vdd_clamp=5 V or 3.3 V
Operating temperature	T <sub>J</sub> maximum = 125°C
Storage temperature range	-55°C to +125°C (-67°F to 257°F)
Power dissipation (typical)	1.2 W @ Vdd=3.3 V with 33-MHz PCI Clock
Package	208-pin PQFP



# Support, Products, and Documentation

If you need technical support, a *Product Catalog*, or help deciding which documentation best meets your needs, visit the Intel World Wide Web Internet site:

<http://www.intel.com>

Copies of documents that have an ordering number and are referenced in this document, or other Intel literature may be obtained by calling **1-800-332-2717** or by visiting Intel's website for developers at:

<http://developer.intel.com>

You can also contact the Intel Massachusetts Information Line or the Intel Massachusetts Customer Technology Center. Please use the following information lines for support:

<b>For documentation and general information:</b>	
Intel Massachusetts Information Line	
United States:	1-800-332-2717
Outside United States:	1-303-675-2148
Electronic mail address:	techdoc@intel.com

<b>For technical support:</b>	
Intel Massachusetts Customer Technology Center	
Phone (U.S. and international):	1-978-568-7474
Fax:	1-978-568-6698
Electronic mail address:	techsup@intel.com