

MITSUBISHI RF POWER TRANSISTOR

2SC2932

NPN EPITAXIAL PLANAR TYPE

DESCRIPTION

2SC2932 is a silicon NPN epitaxial planar type transistor specifically designed for power amplifiers applications in 800–940 MHz UHF band.

FEATURES

- High power gain: $G_p \geq 7.8\text{dB}$, $P_o \geq 6\text{W}$
@ $f = 900\text{MHz}$, $V_{CC} = 12.5\text{V}$
- Emitter ballasted construction
- Gold metalization die in the transistor
- High ruggedness high reliability: Ability to withstand 20:1 load VSWR when operated at $V_{CC}=15.2\text{V}$, $P_o=6\text{W}$, $f=900\text{MHz}$.
- Small size, low common lead inductance strip line type ceramic package.
- Common base configuration.
- Series equivalent input/output impedance
 $Z_{in} = 2.8-j1.4 (\Omega)$, $Z_{out} = 4.7-j5.9 (\Omega)$
Operated at $f = 900\text{MHz}$, $V_{CC} = 12.5\text{V}$, $P_o = 6\text{W}$

APPLICATION

RF power amplifiers applications in 800 to 940 MHz mobile radio sets.

OUTLINE DRAWING

Dimensions in mm

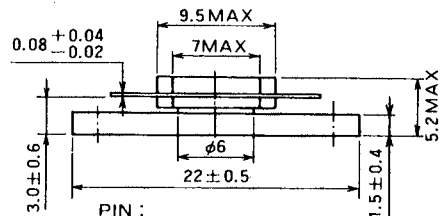
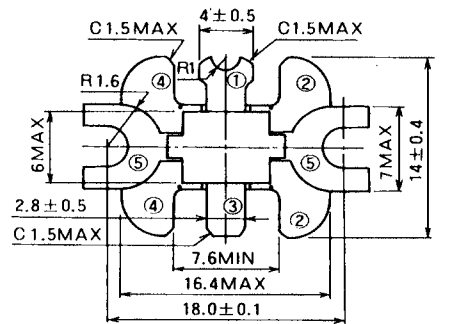

- PIN :
- ① COLLECTOR
 - ② BASE (FLANGE)
 - ③ EMITTER
 - ④ BASE (FLANGE)
 - ⑤ FIN (BASE)

T-31B

ABSOLUTE MAXIMUM RATINGS ($T_C = 25^\circ\text{C}$ unless otherwise specified)

Symbol	Parameter	Conditions	Ratings	Unit
V_{CBO}	Collector to base voltage		35	V
V_{EBO}	Emitter to base voltage		3	V
V_{CEO}	Collector to emitter voltage	$R_{BE} = \infty$	17	V
I_C	Collector current		2	A
P_C	Collector dissipation	$T_C = 25^\circ\text{C}$	20	W
T_j	Junction temperature		175	$^\circ\text{C}$
T_{stg}	Storage temperature		-55 to 175	$^\circ\text{C}$
R_{th-c}	Thermal resistance	Junction to case	7.5	$^\circ\text{C/W}$

Note. Above parameters are guaranteed independently.

ELECTRICAL CHARACTERISTICS ($T_C = 25^\circ\text{C}$ unless otherwise specified)

Symbol	Parameter	Test conditions	Limits			Unit
			Min	Typ	Max	
$V_{(BR)EBO}$	Emitter to base breakdown voltage	$I_E = 10\text{mA}$, $I_C = 0$	3			V
$V_{(BR)CBO}$	Collector to base breakdown voltage	$I_C = 10\text{mA}$, $I_E = 0$	35			V
$V_{(BR)CEO}$	Collector to emitter breakdown voltage	$I_C = 0.1\text{A}$, $R_{BE} = \infty$	17			V
I_{CBO}	Collector cut-off current	$V_{CB} = 15\text{V}$, $I_E = 0$			2	mA
I_{EBO}	Emitter cut-off current	$V_{EB} = 2\text{V}$, $I_C = 0$			2	mA
h_{FE}	DC Current gain *	$V_{CE} = 10\text{V}$, $I_C = 0.1\text{A}$	10	30	180	—
P_O	Output power	$f = 900\text{MHz}$, $V_{CC} = 12.5\text{V}$, $P_{in} = 1\text{W}$	6	7		W
η_C	Collector efficiency		55	65		%

Note. * Pulse test, $P_w = 150\mu\text{s}$, duty=5%.
Above parameters, ratings, limits and conditions are subject to change.

MITSUBISHI RF POWER TRANSISTOR 2SC2932

NPN EPITAXIAL PLANAR TYPE

TEST CIRCUIT (f=900MHz)

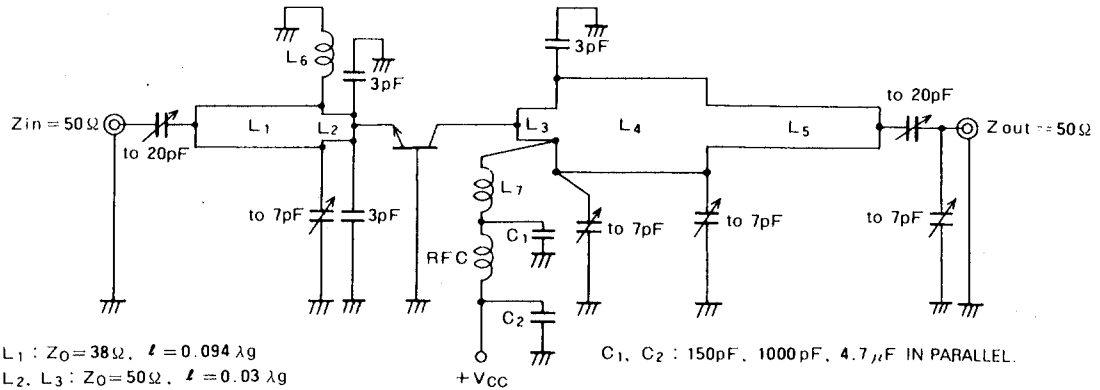

- L₁ : Z₀ = 38Ω, l = 0.094 λg
- L₂, L₃ : Z₀ = 50Ω, l = 0.03 λg
- L₄ : Z₀ = 20Ω, l = 0.104 λg
- L₅ : Z₀ = 38Ω, l = 0.123 λg
- L₆ : 4D, 12 T, OP (φ0.8 SILVER PLATED COPPER WIRE)
- L₇ : l = 25, (φ1.0 SILVER PLATED COPPER WIRE)

Note: Board Material: Glass Teflon, t=1.6, ε_r=2.7
 D: Inner Diameter, T: Turn Number, P: Pitch.
 All dimensions in mm.

TYPICAL PERFORMANCE DATA

COLLECTOR DISSIPATION VS. AMBIENT TEMPERATURE

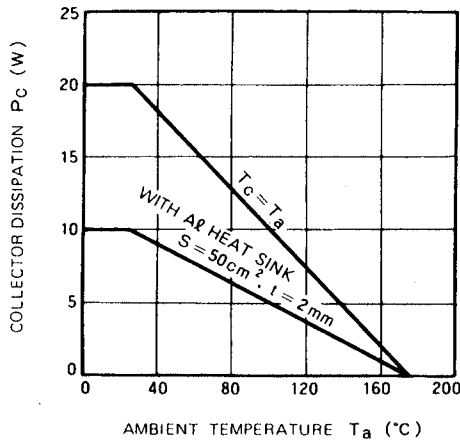

COLLECTOR OUTPUT CAPACITANCE VS. COLLECTOR TO BASE VOLTAGE

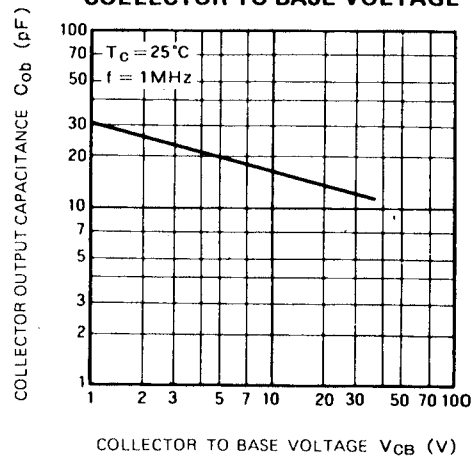

OUTPUT POWER, COLLECTOR EFFICIENCY VS. INPUT POWER

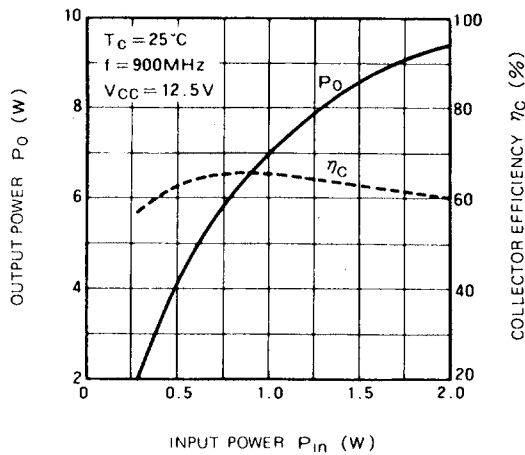

OUTPUT POWER VS. COLLECTOR SUPPLY VOLTAGE

