

SANYO**LA1136N, 1136NM, 1137N, 1137NM****AM Tuners for Car Radios and Home Stereos****Overview**

The LA1136N/NM and LA1137N/NM are high-performance AM electronic tuner ICs offering sophisticated functions. They are especially suited for use in car radio and home stereo (antenna: loop) applications.

Functions

- MIX
- OSC (with ALC)
- IF amplifier
- Detector
- AGC (normal)
- RF wide-band AGC
- Auto search stop signal (Signal meter output)
- Local oscillation buffer output
- IF band switching circuit (for LA1136N only)
- IF count buffer
- Stop detector output (can be set independently)
- Tweet prevention circuit
- AGC (RF, IF) time constant switching circuit
- IF AGC circuit
- Pin-diode driver
- AM stereo decoder IF output (for LA1136N only)
- Circuit preventing incorrect seek operation

Features

- Excellent cross modulation characteristic: Meets the requirements for preventing not only adjacent-channel interference but also interference caused by all channels within broadcast band.
- Narrow-band signal meter output: Usable as auto search stop signal. Has linearity up to 100 dB μ .
- Local oscillation buffer output: Facilitates designing of electronic tuner system, frequency display, etc.
- OSC (with ALC): Improves tracking error because oscillation output is stabilized at a low level (350 mVrms: LA1137N) for varactor diode.
- MIX: Double-balanced differential MIX meeting the requirements for preventing spurious interference, IF interference.
- Good characteristic at high input: 130 dB μ input fm = 400 Hz 80%mod THD = 0.5% typ.
- High S/N: Good S/N at medium input (55 dB typ).
- Usable sensitivity: (S/N = 20 dB input): 25 dB μ (when using 2SK715)
- V_{CC} variation compensation: Less variation in gain, distortion: 8 to 12 V

AM stereo capability (LA1136N only)

- IF band switching circuit on chip; controlled by microcontroller
- Oscillating circuit for AM stereo; SUB S/N improved to 6 dB
- IF output for AM stereo decoder
- Improved tweet characteristics: 10 dB increase, controlled by microcontroller
- Improved cross modulation characteristics, especially sensitivity suppression characteristics: 15 dB improvement, wide-band AGC operation even for SW band interference
- Improved low-frequency modulation distortion
- Improved temperature characteristics: S-meter, SD sensitivity
- Faster RF AGC response: RF: 1/3; IF: 1/8 (compared to predecessors)
- Improved capability for driving external RF AGC transistors: I_B max = 200 μ A
- Measures to prevent incorrect seek operation
 - IF count buffer on chip; controlled by microcontroller
 - Time constant switching circuit on chip for RF and IF AGC
 - IF AGC clear circuit on chip
 - Measures that prevent stopping one station too soon

Package Dimensions

unit : mm

3067-DIP24S

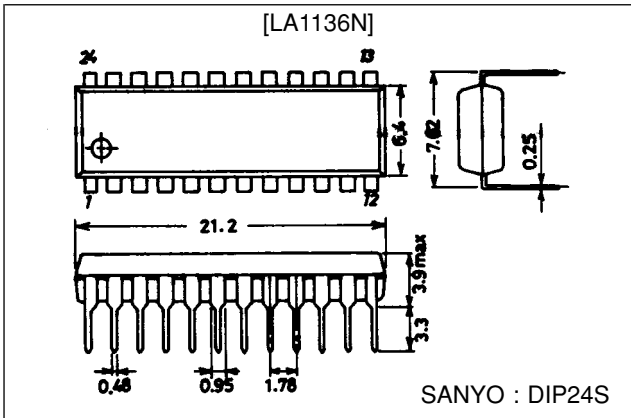

unit : mm

3112-MFP24S

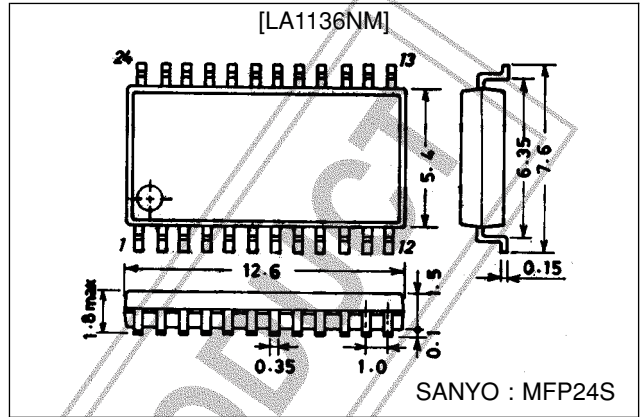

unit : mm

3021B-DIP20S

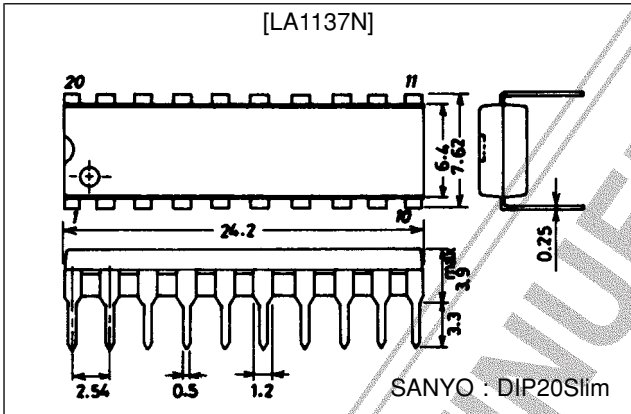

unit : mm

3036B-MFP20

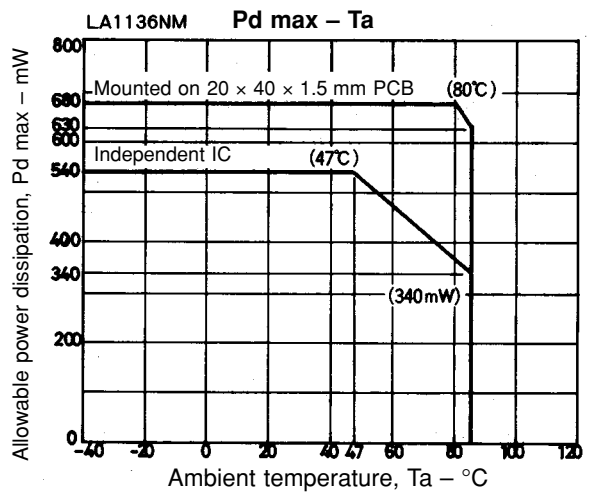
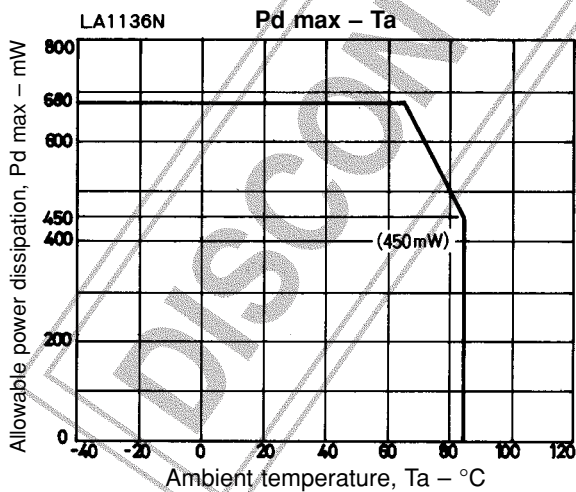
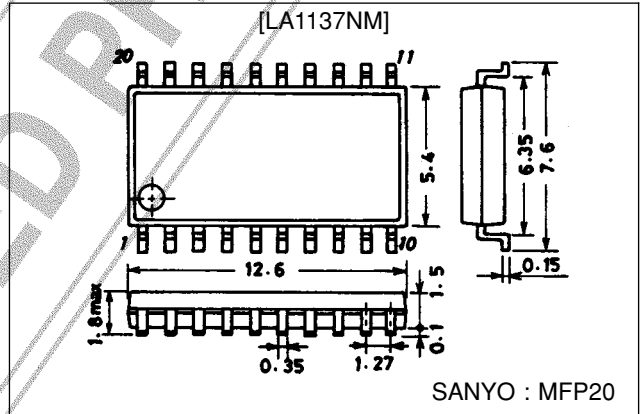

LA1136N, 1136NM, 1137N, 1137NM

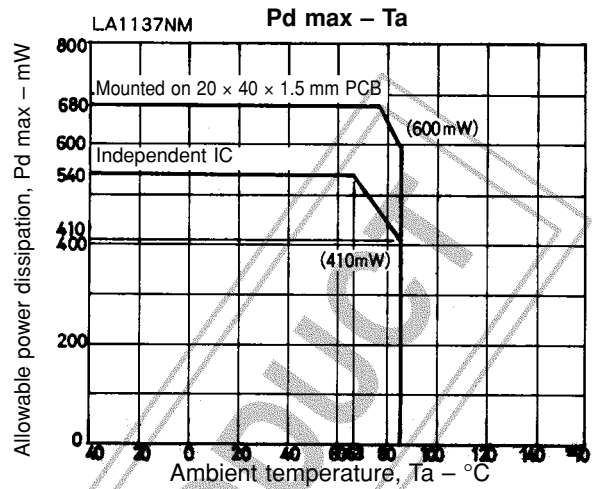
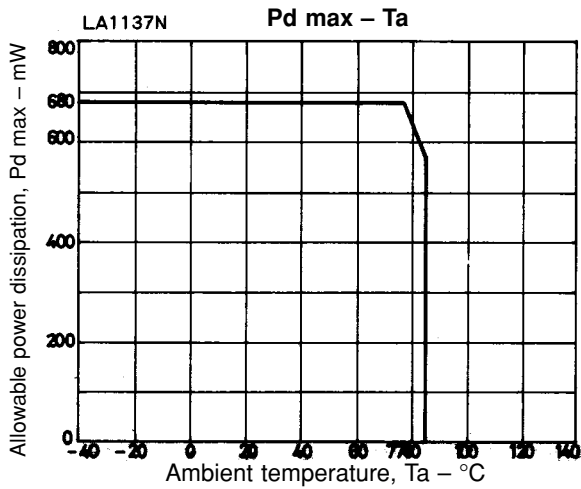

Specifications

Maximum Ratings at Ta = 25°C

Parameter	Symbol	Conditions	Ratings	Unit
Maximum supply voltage	V _{CC} max	Pin 19 (LA1136N), Pin 15 (LA1137N)	12	V
Output voltage	V _{O1}	Pin 6	13.4	V
	V _{O2}	Pin 13 (LA1136N), Pin 10 (LA1137N)	15.5	V
Input voltage	V _{IN}	Pin 5	5.6	V
Current drain	I _{CC}	Pin 15+6+10, V ₁₁ = 0 (LA1137N) Pin 6+13+19, V ₁₄ = 0 (LA1136N)	60	mA
Flow-out current	I ₂₀	Pin 20 (LA1137N), Pin 24 (LA1136N)	2	mA
Allowable power dissipation	Pd max	Ta ≤ 65°C (LA1136N), Ta ≤ 77°C (LA1137N)	680	mW
	Pd max1	Independent IC, Ta ≤ 47°C (LA1136NM)	540	mW
	Pd max2	With PCB, Ta ≤ 80°C (LA1136NM)	680	mW
	Pd max1	Independent IC, Ta ≤ 63°C (LA1137NM)	540	mW
	Pd max2	With PCB, Ta ≤ 77°C (LA1137NM)	680	mW
Operating temperature	Topr		-40 to +85	°C
Storage temperature	Tstg		-40 to +125	°C

Operating Conditions at Ta = 25°C

Parameter	Symbol	Conditions	Ratings	Unit
Recommended supply voltage	V _{CC}		8	V
Supply voltage range	V _{CC} op		7.5 to 10	V

LA1136N, 1136NM, 1137N, 1137NM

LA1136N, LA1136NM

Operating Conditions at $T_a = 25^\circ\text{C}$, $V_{CC} = 8\text{ V}$, $f_r = 1\text{ MHz}$, $f_m = 400\text{ Hz}$, See specified Test Circuit

Parameter	Symbol	Conditions	Pin				min	typ	max	Unit
			12	14	17	22				
Current drain	I_{CC1}	Quiescent	L	L	L	O	22	38	52	mA
	I_{CC2}	130 dB μ	L	L	L	O	30	45	60	
Detection output	V_O	74 dB μ , 30% modulation	L	L	L	O	-15.0	-12.0	-9.0	dBm
Signal-to-noise ratio	S/N	74 dB μ , 30% modulation	L	L	L	O	49	54		dB
AGC figure-of-merit	AGC	74 dB μ , 30% modulation, reference output 10 dB below input	L	L	L	O	50	54		dB μ
Total harmonic distortion	THD1	74 dB μ , 80% modulation	L	L	L	O		0.4	1.0	%
	THD2	130 dB μ , 80% modulation	L	L	L	O		0.5	2.0	
Signal meter output voltage	V_{SM1}	Quiescent	L	L	L	O		0	0.3	V
	V_{SM2}	130 dB μ	L	L	L	O	3.5	5.0	7.5	
Stop detector sensitivity	SD	$V_{18} = 3.5\text{ V}$	L	H	L	O	26	32	38	dB μ
Local-oscillator buffer output voltage	$V_{OSC\text{ BUFF}}$	Quiescent	L	L	L	O	270	330		mVrms
IF buffer output voltage	$V_{IF\text{ BUFF}}$	74 dB μ , zero modulation	L	L	L	O	530	750	1,000	mVrms
IF count buffer output voltage	V_{IFCB}	30 dB μ , zero modulation	L	H	H	O	260	300		mVrms
IF count buffer output leakage voltage	V_{IFCBL}	74 dB μ , zero modulation	L	L	L	O			10	mVrms
Antenna input level for RF AGC ON and tweet prevention	ANT1		L	L	L	L	56	62	68	dB μ
Antenna input for wideband AGC ON	ANT2	Quiescent, 1.0-MHz receive signal, 1.4 MHz interference, zero modulation	L	L	L	O	92	98	104	dB μ
Wideband/narrowband detector output ratio (weak input)	-	21 dB μ , 30% modulation	L/H	L	L	O		2	4	dB
Pin-diode driver current	I_{ANTD}	$V_1 = 0.7\text{ V}$	L	L	L	O	4.0	5.5		mA

Note) SW voltage: H = 5 V, L = GND, O = OPEN

LA1137N, LA1137NM

Operating Characteristics at $T_a = 25^\circ\text{C}$, $V_{CC} = 8\text{ V}$, $f_r = 1\text{ MHz}$, $f_m = 400\text{ Hz}$, See specified Test Circuit

Parameter	Symbol	Conditions	SW			min	typ	max	Unit
			11	13	18				
Current drain	I_{CC1}	Quiescent	L	L	O	22	38	52	mA
	I_{CC2}	130 dB μ , zero modulation	L	L	O	30	45	60	
Detection output	V_O	74 dB μ , 30% modulation	L	L	O	-15.0	-12.0	-9.0	dBm
Signal-to-noise ratio	S/N	74 dB μ , 30% modulation	L	L	O	50	55		dB
AGC figure-of-merit	AGC	74 dB μ , 30% modulation, reference output 10 dB below input	L	L	O	48	52	56	dB
Total harmonic distortion	THD1	74 dB μ , 80% modulation	L	L	O		0.3	1.0	%
	THD2	130 dB μ , 80% modulation	L	L	O		0.4	2.0	
Signal meter output voltage	V_{SM1}	Quiescent	L	L	O		0	0.3	V
	V_{SM2}	130 dB μ , zero modulation	L	L	O	3.5	5	7.5	
Stop detector sensitivity	SD	$V_{18} = 3.5\text{ V}$, zero modulation	H	L	O	27	33	39	dB μ
Local-oscillator buffer output voltage	$V_{OSC\text{ BUFF}}$	Quiescent	L	L	O	290	350		mVrms
IF count buffer output voltage	V_{IFCB}	30 dB μ , zero modulation	H	H	O	260	300		mVrms
IF count buffer output leakage voltage	V_{IFCBL}	74 dB μ , zero modulation	L	L	O			10	mVrms
Antenna input for RF AGC ON and tweet prevention	ANT1		L	L	L	56	62	68	dB μ
Antenna input for wide band AGC ON	ANT2	Quiescent, 1.0 MHz receive signal, 1.4 MHz interference signal, zero modulation	L	L	O	92	98	104	dB μ
Pin-diode driver current	I_{ANTD}	$V_1 = 0.7\text{ V}$	L	L	O	4.0	5.5		mA

Note) SW voltage: H = 5 V, L = 0 V, O = open

Short the ammeter used to measure the pin-diode driver current when not in use.

LA1136N Equivalent Circuit

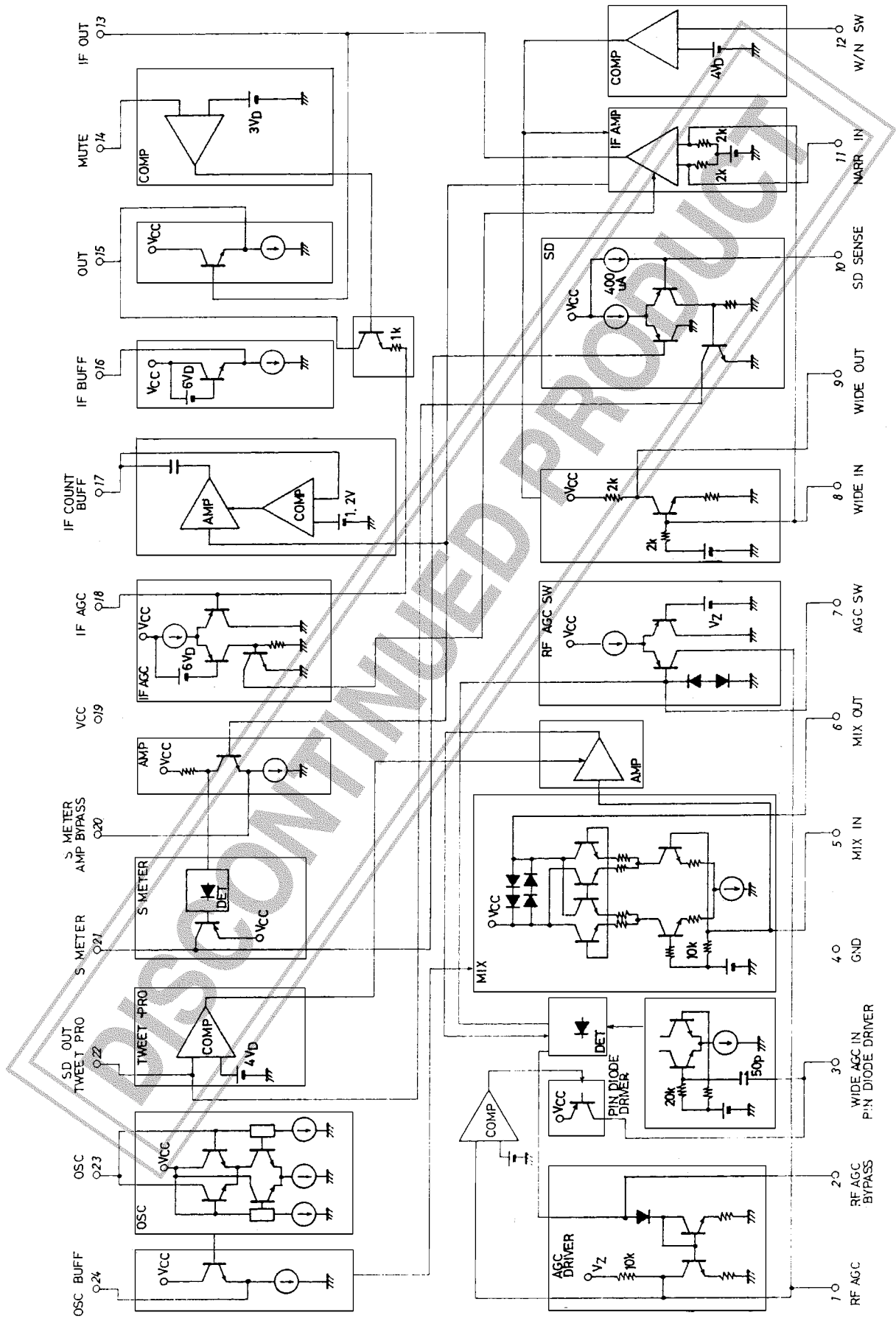

LA1137N Equivalent Circuit

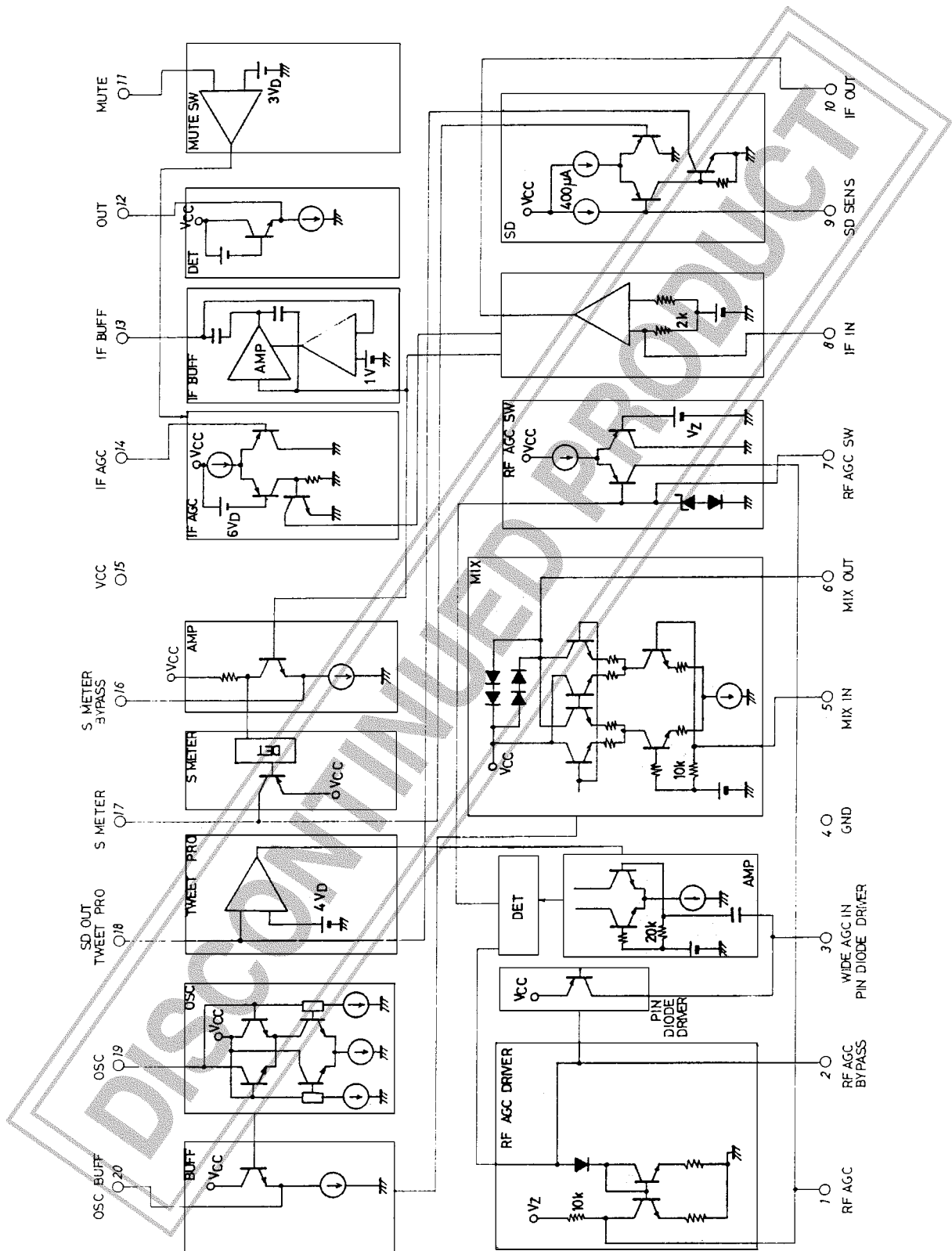

LA1137N Sample Application Circuit

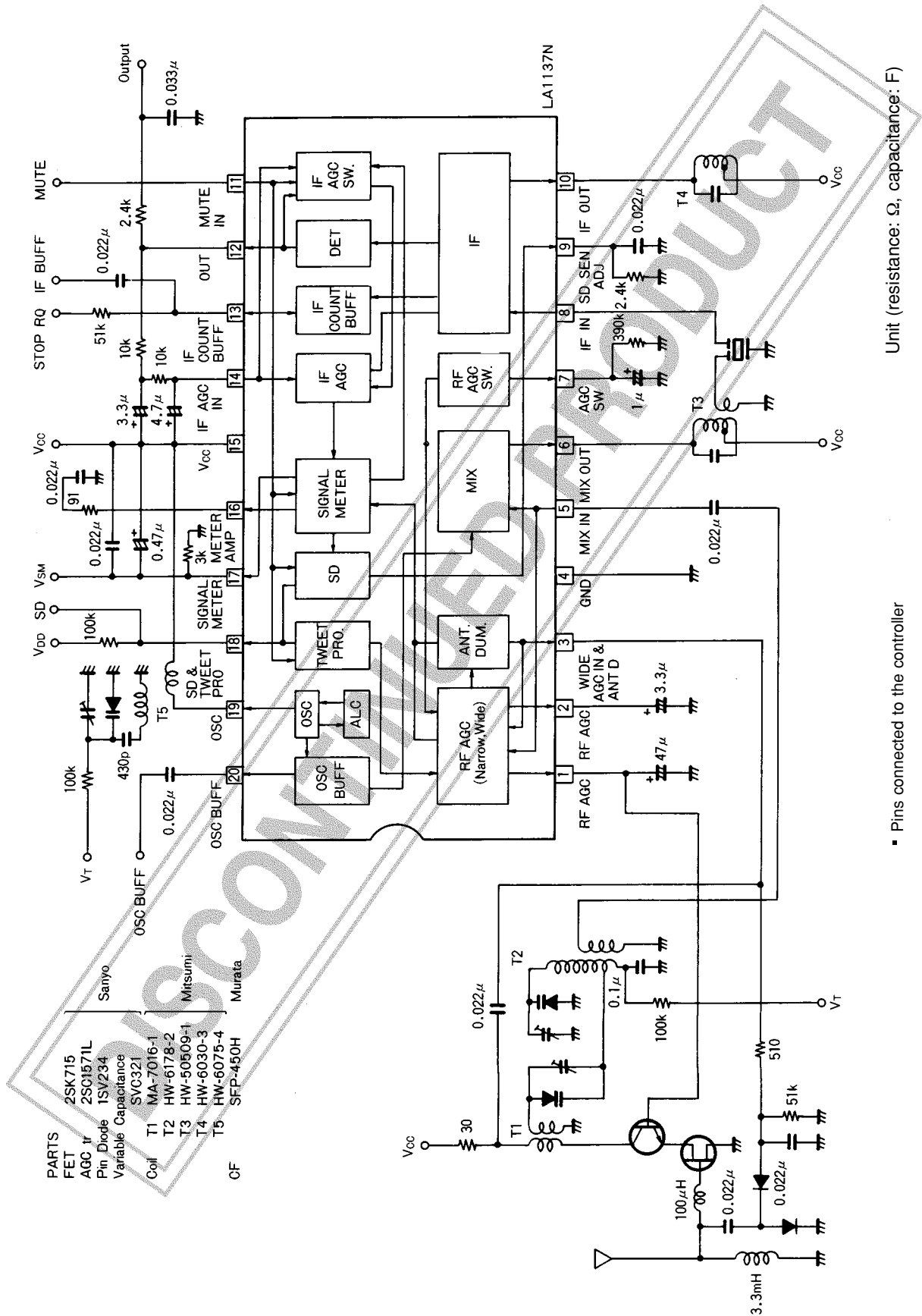

PARTS

FET	2SK715	Sanyo
AGC	2SQ1571L	Sanyo
Pin Diode	1SV234	Sanyo
Variable Capacitance	SVC321	Sanyo
Coil	T1 MA-7016-1	Mitsumi
	T2 HW-6178-2	Mitsumi
	T3 HW-50509-1	Mitsumi
	T4 HW-6030-3	Mitsumi
	T5 HW-6075-4	Mitsumi
CF	SFP-450H	Murata

Unit (resistance: Ω, capacitance: F)

▪ Pins connected to the controller

LA1136N, LA1137N Pin Specifications (Pins connected to an external microcontroller)

- (1) IF Band Switching : Pin 12
 Narrowband : 3.5 V or greater
 Wideband : 2.1 V or lower
- (2) Seek Detection : Pin 14
 Station seek : 3.5 V or greater
 Receive mode : 1.5 V or lower
- (3) IF Count Buffer : Pin 17
 IF count buffer enabled : 2.5 V or greater
 IF count buffer disabled : 1.2 V or lower
- (4) SD output, tweet prevention control pin: Pin 22
 The function of pin 22 is determined by the control voltage on pin 14 as follows:

[Pin 14]	[Pin 22]
HIGH (3.5 V or higher) →	SD output pin (active high)
LOW (1.5 V or lower) →	Tweet prevention input pin
	Microcontroller control voltage, Tweet prevention
	HIGH (3.5 V or higher) off
	LOW (1.5 V or lower) on

Note: It is necessary to modify the microcontroller specifications in order to implement tweet prevention. When a conventional microcontroller is used with the LA1136N or the LA1137N, the tweet prevention circuit does not operate, but all other functions operate independently.

Device Comparison

Comparison between LA1135, LA1136N and LA1137N

Parameter	LA1135	LA1136N	LA1137N
Packages	DIP20S, MFP20	DIP24S, MFP24	DIP20S, MFP20
Double-balanced mixer	Yes	Yes	Yes
Oscillator	LW to SW	Supports AM stereo in LW and MW, low-band noise reduction	LW to SW
Local-oscillator buffer	Yes	Yes	Yes
IF amplifier	Yes	Yes	Yes
Detector	External capacitor	Internal capacitor	Internal capacitor
IF-band switching	No	Yes	No
S-meter linearity	Approximately 80 dBμ	Approximately 100 dBμ	Approximately 100 dBμ
Active-HIGH stop detector output	No (requires 2 transistors)	Yes	Yes
Stop detector sensitivity	S-meter load dependent	Set by external resistor (Pin 10)	Set by external resistor (Pin 9)
IF count buffer	No (requires 2 transistors)	Yes	Yes
AM stereo buffer	No	Yes	No
IF AGC	Yes	Yes	Yes
IF AGC time-constant switching	No (requires 1 transistor)	Yes	Yes
IF AGC reset	No	Yes	Yes
Wideband RF AGC	Yes	Yes	Yes
RF AGC time-constant switching	No	Yes	Yes
Antenna dumping	Transistor	Pin-diode	Pin-diode
Tweet prevention	No	Yes	Yes

LA1136N, LA1137N Usage Notes

1. Do not connect the antenna alignment circuit and local oscillation circuit.
2. The coils should be specified to obtain an output level of -25 dBm (43.6 mVrms) for the given input levels shown below, and under the conditions $f_m = 400$ Hz, 30% modulation and $f_{OSC} = 1.45$ MHz.

Antenna input	20.0 dB μ (Note)
Mixer input	30.5 dB μ
IF input	38.0 dB μ
Detector input	106.0 dB μ

Input connections

Antenna input

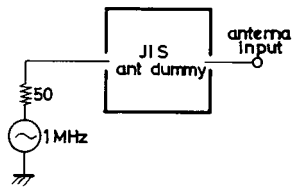

Mixer input

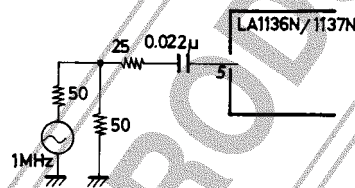

IF input

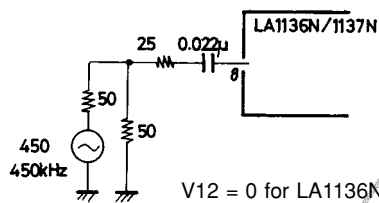

Detector input

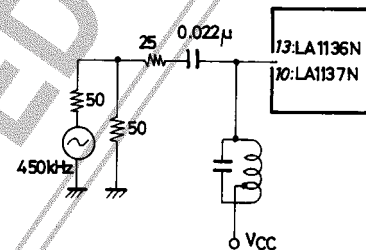

Unit (resistance: Ω , capacitance: F)

Note : The antenna input can be adjusted by changing the number of turns in the primary winding of the alignment coil in accordance with the AGC figure-of-merit.

3. Coil Design Notes

(1) RF alignment coil

- Gain adjustment: The gain is adjusted by varying the primary turns ratio of the primary coil.
- Coupling: The design of this coil is geared towards critical coupling.

The coupling is dependent on the turns ratio of the primary coil and the secondary coil:

Tight coupling: High turns ratio

Loose coupling: Low turns ratio

- With tight coupling, the selectivity characteristic develops a double hump; when making a tracking adjustment, it must be noted that misadjustment can occur, leading to a deterioration of the dual signal characteristics.
- With loose coupling, selectivity increases, but the sensitivity error within the band of the RF alignment itself also increases.

During design, be certain to confirm data such as that for coil specifications. Furthermore, it is also necessary to note that although the turns ratio of the primary and secondary coils have the greatest bearing on coupling, the shape of the coil core and the manner in which the coil is wound also have an impact.

(2) Oscillator coil

The oscillator for LA1136N and LA1137N can operate up to 100 MHz. Stray capacitance resulting from poor oscillator coil design can cause antiresonance in the range 50 to 100 MHz. This results in parasitic oscillations at the local-oscillator buffer output, which can prevent the PLL from locking.

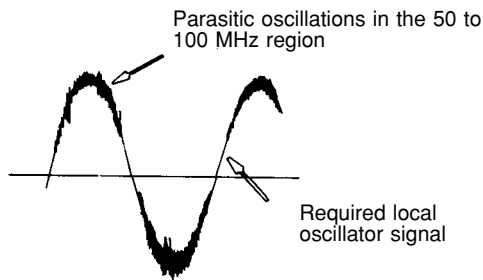

Countermeasure

- ① Reduce the oscillator coil stray capacitance (tapping is recommended)
- ② Connect a capacitor of 43 pF or greater between OSC BUFF (Pin 24 for LA1136N, and Pin 20 for LA1137N) and GND.

(3) IF tank coil

LA1136N Pin 13 load coil
LA1137N Pin 10 load coil

The IF tank coil connected to IF OUT has different specifications to that of the LA1135. The detector input impedance of the LA1135 is low, therefore for a Q_O of 70 to 80, the Q_L was 20 to 30. The detector input impedances of the LA1136N and LA1137N are higher. This means that the Q_O and Q_L of the tank coil are approximately the same. A coil with a Q_O of approximately 30 is recommended.

4. Recommended Coil Specifications

(1) RF alignment coil

Primary coil

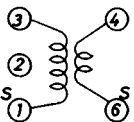

	MA-7016-1(Mitsumi)	SA-067(Sumida)
1-3	76	85
4-6	7	7
L ₁₋₃ = 224 uH		

Secondary coil

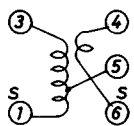

	HW-6178-2(Mitsumi)
1-5	1 1/2
6-4	16
5-3	74 1/2

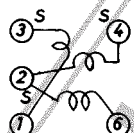

	SA-063(Sumida)
4-2	3 1/2
3-1	16
2-6	68 1/2

LA1136N, 1136NM, 1137N, 1137NM

(2) Oscillator coil

For use with SVC321, triple varactor diode

		YD-9632-1	
		(Mitsumi)	(Sumida)
	④	1-3	57
	⑥	2-3	19
		$L_{1-3} = 118 \mu\text{H}$	

For use with quad varactor diode

		YD-9494-1	
		(Mitsumi)	(Sumida)
	④	1-3	55
	⑥	2-3	18
		$L_{1-3} = 85 \mu\text{H}$	

(3) Mixer coil

		HW-50509-1(Mitsumi)	SA-045(Sumida)
			④
⑥	6-4		26
	2-3		100
		Center frequency	450kHz
		Q_0	37
		C_{in}	180pF
			45
			180pF

(4) IF tank coil

		HW-6030-3(Mitsumi)	SA-044(Sumida)
			④
⑥	2-3		69
			Center frequency
		Q_0	37
		C_{in}	180pF
			45
			180pF

DISCONTINUED PRODUCT

LA1136N, 1136NM, 1137N, 1137NM

- (5) Sample RF alignment coil selectivity characteristics (Mitsumi)
 New coil designs should have the same selectivity characteristics as shown below.

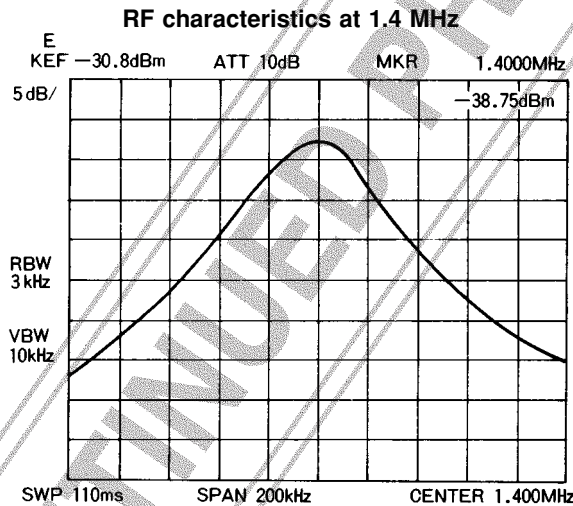
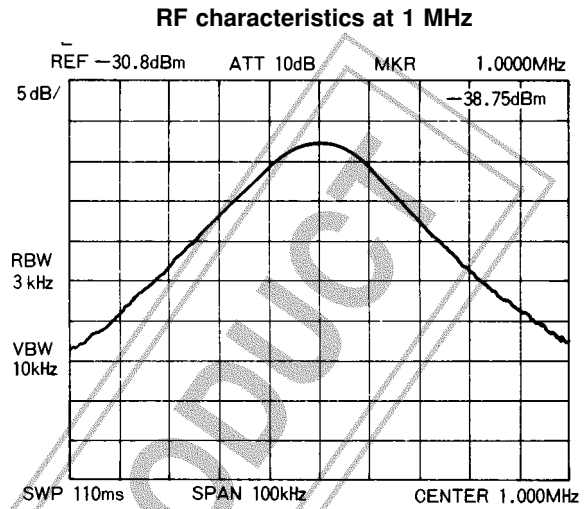
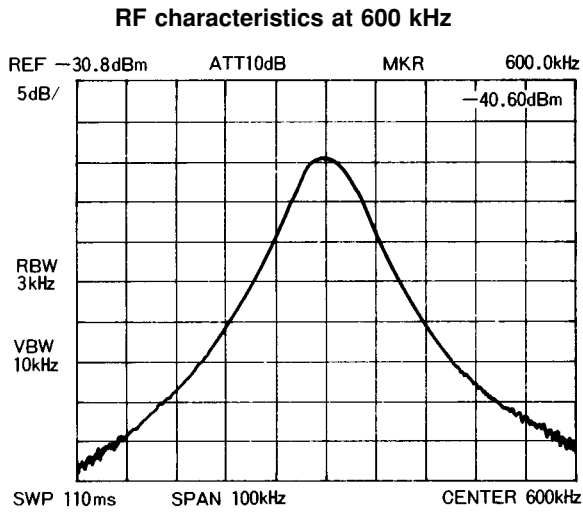

5. Problems Concerning Wideband AGC

Because the LA1136N and the LA1137N offer many sophisticated functions, a number of their pins are dual-purpose pins. An example is pin 3 (on both the LA1136N and the LA1137N), which serves both as the wideband AGC input pin and the antenna dumping pin diode drive pin. As a result, particular attention must be given to the wiring pattern layout, since feedthrough of other signals as shown in the figure below can cause AGC to operate without input, resulting in reduced sensitivity.

Avoid direct feedthrough from the RF amplifier to the pin 3 line.

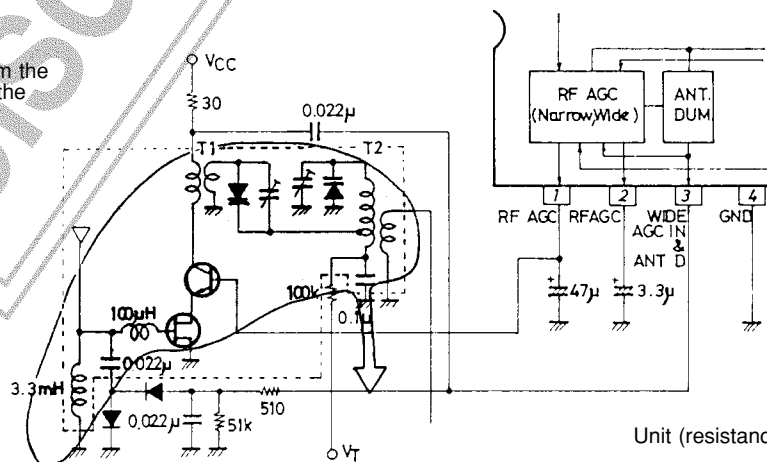

LA1136N/1137N Antenna, RF circuit

LA1136N, 1136NM, 1137N, 1137NM

6. Wideband AGC Sensitivity

The wideband AGC circuit two-signal sensitivity and shortwave interference suppression characteristics have been achieved by reducing the sensitivity by approximately 10 dB from that of previous devices. If a FET with low g_m and high I_{DSS} is used, the sensitivity can be increased by increasing the external sensitivity adjustment resistor (30 Ω). However, the voltage drop across this resistor can cause the cascade AGC transistor to saturate. Therefore, if the sensitivity is to be increased by a large amount, a choke coil should be added as shown in the figure below.

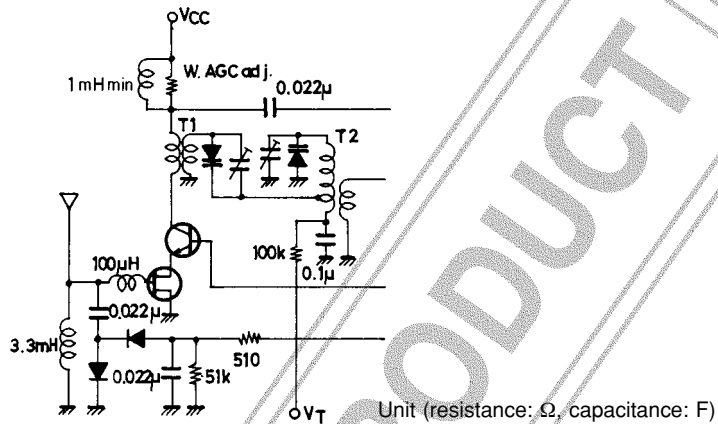

7. The local oscillation level increased during LW (approx. 50°C or greater)

27 k Ω should be added between pins 19 and 23 for LA1136N, and between pins 15 and 19 for LA1137N. Not necessary for MW.

8. Image Interference Reduction

Image interference in the alignment circuit can be reduced by up to 70 dB at $f_r = 1.4$ MHz by injecting a 2.3 MHz trap signal into the primary coil. Note that this technique reduces the sensitivities at frequencies above 1.4 MHz.

9. Upgraded Features of LA1136 and LA1137 to LA1136N and LA1137N

Upgraded features	LA1136, LA1137	LA1136N, LA1137N
IF count buffer output voltage 74 dB μ , zero modulation, $f_r = 1$ MHz when STOP RQ = 0 V Test circuit LA1137N	80 mVp-p	1.5 mVp-p
Signal detector output voltage when V_{CC} OFF Test circuit LA1137N	0.7 V	5 V

Unit (resistance: Ω , capacitance: F)

LA1136N, 1136NM, 1137N, 1137NM

10. Application Circuit using the IF count method

The LA1136N and LA1137N can be configured for tuning using either the stop detector or the IF count method. The application circuits are examples of tuners using the IF count method. The stop detector can be used in any of the application circuits by making the circuit modifications shown below.

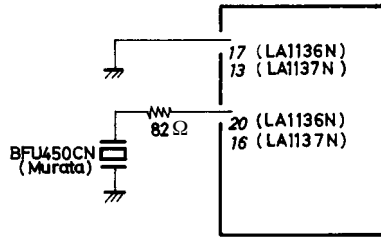

The other pins are the same as those shown in the application circuits.

11. Improving Fidelity

Distortion for low-frequency ($f_m \leq 100$ Hz), high-modulation signals can be reduced by increasing the capacitance connected to RF AGC of pins 1 and 2 (LA1136N, LA1137N). However, increasing this capacitance (C_2) by a large amount can increase the AGC response time to an unacceptable level.

12. Loop Antenna Specifications

The recommended loop antennae for the LA1136N and LA1137N are the Korin 42579719100 (LA-1500) and 4257976000 (LA-100A). Note that these are the same antennae previously recommended for the LA1135.

13. AGC ON Level Frequency Characteristics

The frequency at which the sensitivity decreases by -3 dB from the point when $f = 1$ MHz is as shown below.

	Normal	Wideband
LA1136N, LA1137N	37 MHz	24 MHz
LA1135	20 MHz	7 MHz

In other words, in AGC for the main signal, the point at which the AGC sensitivity drops 3 dB is 37 MHz, as shown in the diagram below. The AGC ON level -3 dB frequencies for narrowband and wideband AGC have been extended from those of the LA1135 to cover the entire SW3 shortwave band. As a result, the wideband AGC sensitivity is significantly increased and susceptibility to shortwave interference, reduced. This has been achieved without any increase in dispersion or distortion.

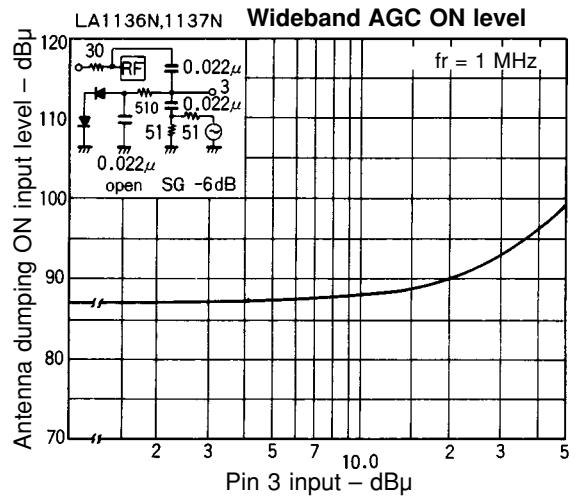
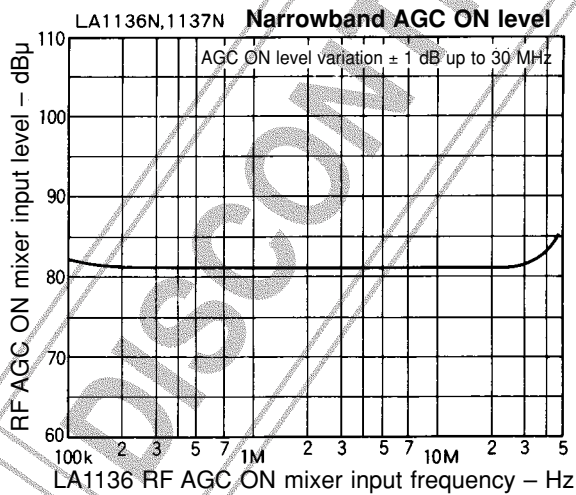

Unit (resistance: Ω , capacitance: F)

14. Stop Detector Adjustment

Although this explanation is for the LA1137N, it is identical for the LA1136N, except that the pin numbers are different. The LA1137N is designed for use with the following microcontrollers.

- Stop detection method: LM7001 (Sanyo) (SD output only)
- IF count method: LM7000 (Sanyo)
- LC7230 (Sanyo)

(1) Support for the LM7001

The search stop detector uses the active HIGH signal of pin18.

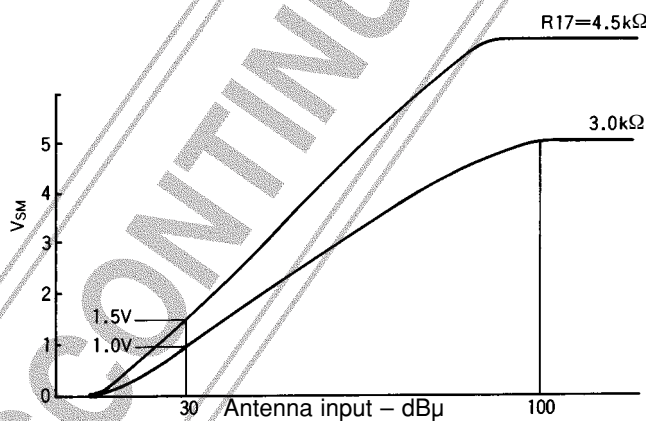
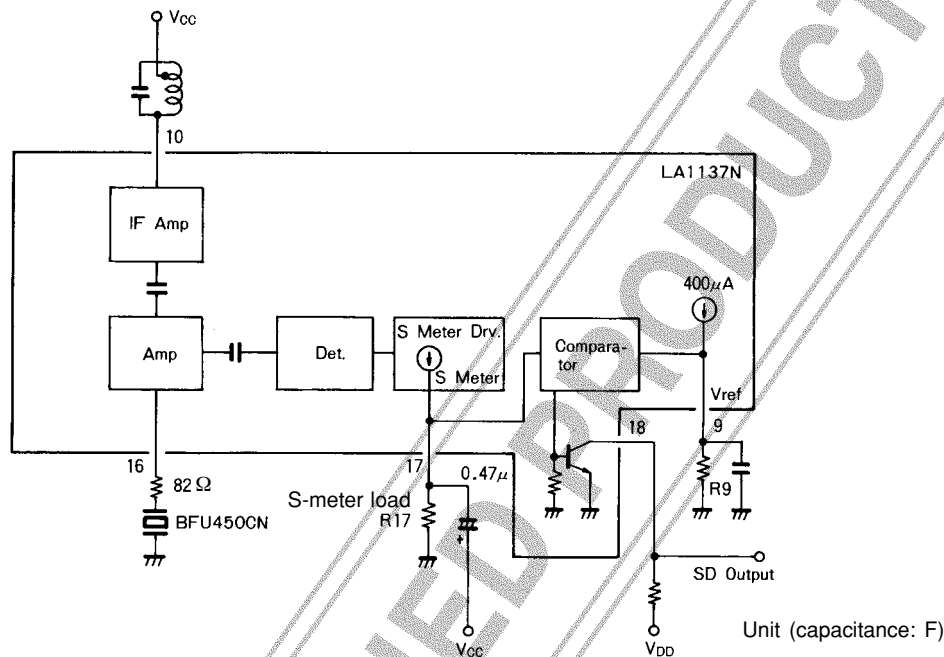

The IF signal from the IF amplifier is detected, on pin 16 the signal that determined the bandwidth characteristics through the narrowband filter BFU450CN (BFU450CN is equivalent to the amplifier emitter load) is detected, and the S-meter output is output by the S-meter drive circuit by driving with current the load on pin 17. Therefore, the S-meter output V_{SM} on pin 17 has the following relationship with the S-meter load R17.

$$V_{SM} \propto R17$$

In the above example, 3 kΩ is changed to 4.5 kΩ, but the R ratio of the output is 1.5x. However, the meter output has an upper limit; as a guide, saturation occurs when the upper limit is at about $V_{CC} - 1.4$ V. The pin 18 SD output is generated by comparing the S-meter output described above with the reference voltage V_{ref} on pin 9 ($400 \mu \times R9$). Using the recommended constants, $V_{ref} = 400 \mu \times 2.4 k = 1.0$ (V).

The comparator compares the electric potential of pin 17 with that of pin 9 and detects when the electric potential of pin 17 is greater than that of pin 9, in which event the transistor is turned off and the SD output changes from LOW to HIGH (GND to V_{DD}).

Note that, in consideration of differences in circuit configurations, V_{ref} should be at least 0.7 V.

(2) SD sensitivity adjustment method

The SD sensitivity is determined by the voltage level of the two inputs to the comparator. Because the absolute value is determined by the resistor as described above, no matter which level, the sensitivity can be adjusted through both levels. However, from the standpoint of the stability of the system as a whole and given the possibility that the S-meter output will be used for other purposes, it is best to make adjustments by adjusting the value on pin 9.

Because the S-meter I/O characteristics during a seek operation or a receive operation are basically as depicted in the diagram below, so allowing for potential differences, the setting level for the adjustable range should be 25 to 60 dBμ.

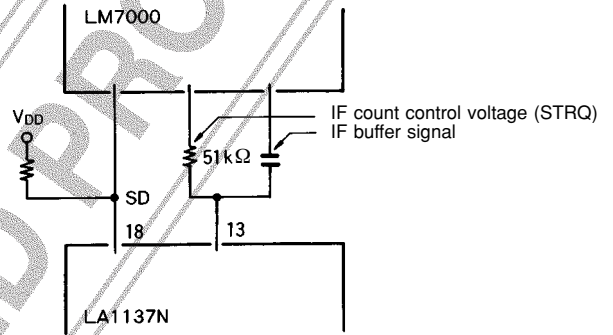
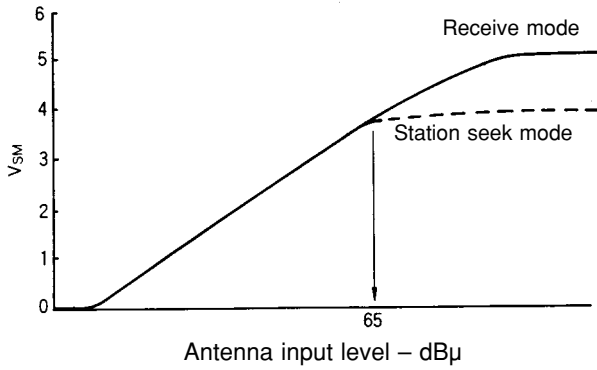

(3) Support for the LM7000 (IF count method)
Implemented as shown in the figure at right.

15. Tweet Prevention Circuit

(1) Cause and countermeasures for Tweet distortion

The beat noise frequency characteristics for LA1137N is $f_r = 900$ kHz and the corresponding circuit where it is generated are shown below. The minimum signal-to-noise ratio for tuners using a reference input signal is 30 dB.

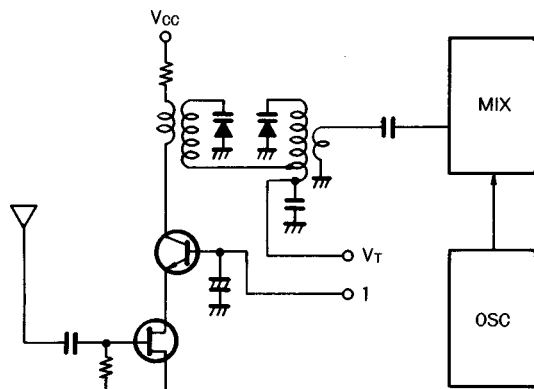
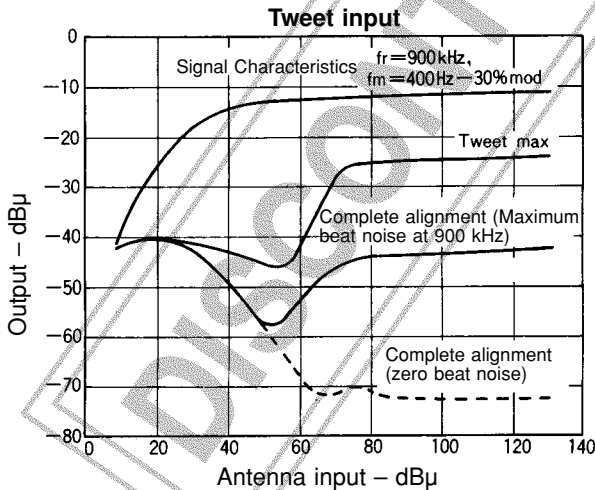

Mechanism behind the deterioration of the characteristics

The 900 kHz RF input signal from the antenna is amplified by the FET RF amplifier before passing through the RF alignment stage to the mixer. If this signal is large, the varactor diodes can cause second-harmonic distortion of 1.8 MHz. The 900 kHz and 1.8 MHz components each generate an IF signal; $(450 + \alpha)$ kHz for the 900 kHz signal, and $(450 - \alpha)$ kHz for the 1.8 kHz signal. These two signals interact to produce a beat frequency at $2 \times \alpha$ kHz.

(2) Methods for improving tweet characteristics

- ① A twin varactor diode can be used, as is used for FM detection. However, the chip size is four times that of a standard varactor diode having the same capacitance, resulting in increased cost and a narrower capacitance range.

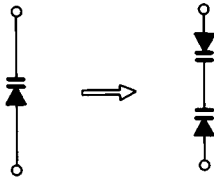

- ② The RF AGC ON level can be reduced to prevent the varactor diodes from distorting the signal. However, the signal-to-noise ratio is limited to approximately 50 dB or lower.
- ③ The varactor diodes can be replaced by an up-converter. However, this increases the susceptibility to interference.

(3) Countermeasures for LA1136N, LA1137N

Although this explanation is for the LA1137N, it is identical for the LA1136N, except that the pin numbers are different.

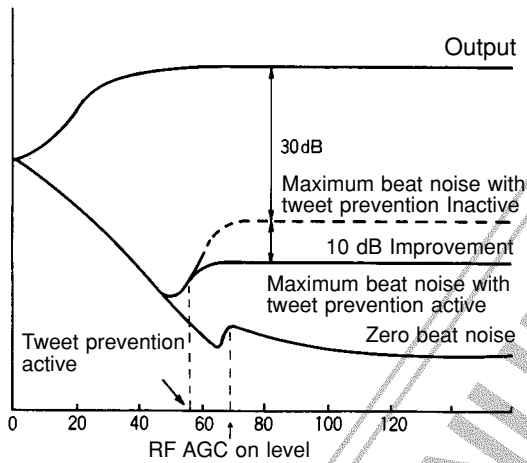

The AGC ON level for $f_r = 90$ kHz is reduced by 10 dB to reduce the signal level on the varactor diodes. The microcontroller determines when the tuner is receiving at 900 kHz and forces the HIGH-level signal present on pin 18 and $SD V_{DD}$ to LOW, reducing the ON level by 10 dB. This gives the signal-to-noise characteristics shown below.

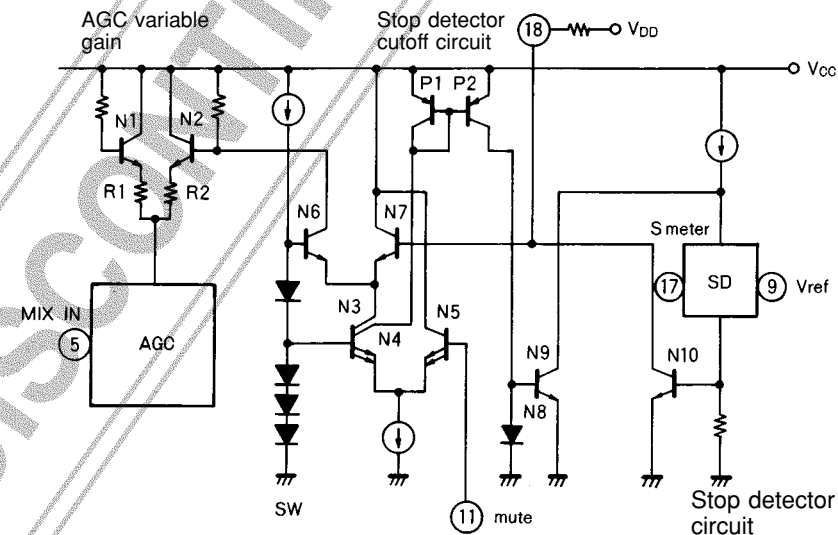

(4) The accurate voltages for each pin

During seek:

When the voltage of pin 11 is HIGH 5 V, transistor N is ON and transistors N3, N4, N6, N7, N8 and N9, OFF.

Pin 18 is connected to the collector of N10 and through a pull-up resistor to V_{DD} .

Pin 18 is the stop detector output when a carrier is present. When N10 is ON, pin 18 is LOW, $V_{18} \approx 0$, and when N10 is OFF, pin 18 is HIGH, $V_{18} \approx V_{DD}$.

During stop:

When the voltage of pin 11 is LOW and the voltage of pin 18 is HIGH, transistor N5 is OFF, and transistors N3, N4, N7, N8, N9, P1 and P2, ON. The SD cut-off circuit for N8 and N9 are ON. Since N9 is ON, no current flows through the stop detector circuit. Therefore the voltage for pin 18 = V_{DD} .

When the microcontroller pulls pin 18 to ground, N5 and N7 turn OFF, and N3, N4, N6, N8, N9, P1 and P2, ON. As a result, N2 is also turned OFF and the amplifier load for $f_r = 900$ kHz is R1. The amplifier load for $f_r = 900$ kHz is $R1 // R2$. The AGC ON level is 10 dB lower for R1, $R1//R2$ than for other frequencies.

16. IF block AGC time constant switching circuit

These tuners incorporate various AGC time constant switching circuits that serve to prevent incorrect stops during seek operations. A summary of these circuits is provided below.

(1) Problems with IF AGC response, such as incorrect stops during seek operations

- ① Incorrect stops (or overshoots) due to S-meter oscillation caused by transient response in IF AGC (secondary filter).
- ② Overshoots of adjacent stations or weak signal stations due to the time required to discharge the electric charge that has built up in the IF AGC capacitor when a seek is initiated while the device is receiving a strong signal

(2) Countermeasures

Although this explanation is for the LA1137N, it is identical for the LA1136N, except that the pin numbers are different.

Countermeasure for problem ①:

When a high signal on pin 11 is detected during a seek operation, change the time constants as indicated below.

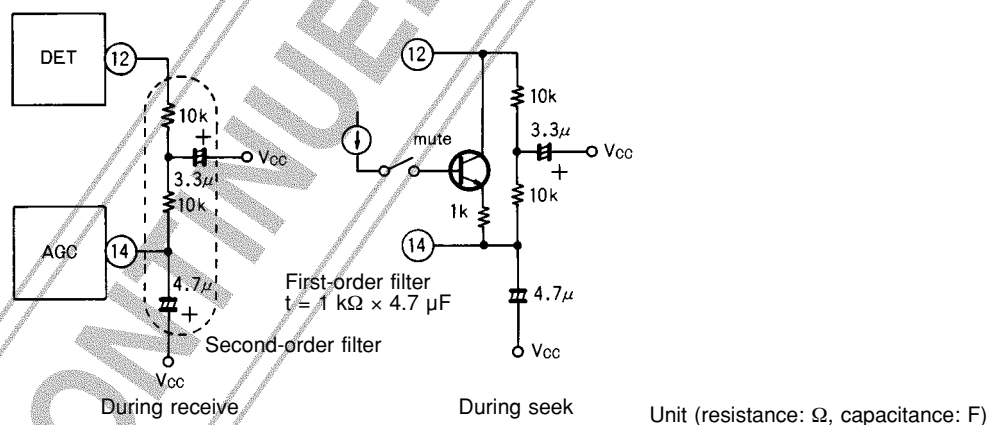

Countermeasure for problem ②:

AGC capacitor discharge times can be reduced by tracking the S-meter output voltage and rapidly discharging the AGC capacitor connected to pin 14 as shown below. This circuit is interlocked with the MUTE signal on pin 11 so that it operates only during seek.

It also reduces the AGC time constant during seek to one-eighth of its normal value.

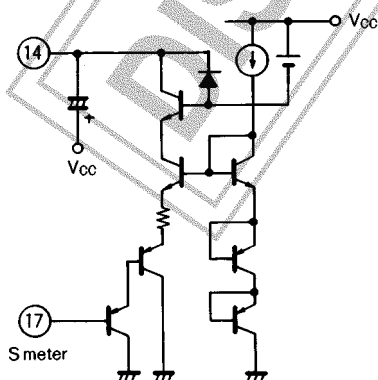

17. Preventing Incorrect RF AGC time-constant switching, Seek Operation

These tuners incorporate various circuits that serve to prevent incorrect stops during seek operation. A summary of the RF amplifiers is provided below.

(1) Incorrect stops during RF AGC, and other problems

- ① The RF AGC response time can cause incorrect seek and stop operation when moving from a weak-signal station to a strong-signal station. When seek operation starts from a strong station, the tuner can overshoot an adjacent weak station if the AGC time constant is too high.
- ② If the wideband AGC ON level is too high, the varactor diodes can generate cross-modulation distortion causing incorrect seek operation.
- ③ Input FETs with high I_{DSS} , required for correct seek and stop operation, are difficult to drive.

(2) Countermeasures

Countermeasure for problem ①:

When the input signal goes from a strong to a weak station, the detector generates a pulse as shown in the figure below. The AGC capacitor C1 is charged rapidly for the duration of this pulse. It also reduces the AGC time constant during charging to one-third of its normal value.

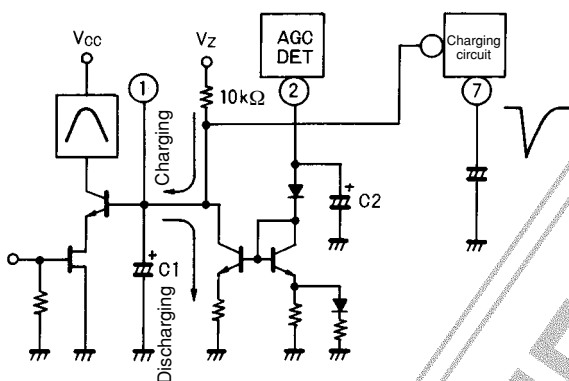

Countermeasure for problem ②:

The wideband AGC ON level should be raised as far as practicable within cross-modulation distortion and sensitivity constraints. If a pin-diode is used, the sensitivity is not suppressed even if the AGC ON level is increased considerably. However, if the varactor diodes in the RF input circuit are exposed to strong interference signals of any frequency, the resulting non-linearity can cause seek and stop operation errors.

Previous devices used the same S-meter linearity for both seek and stop operations, where the linearity was extended to 100 dBμ by the IF AGC and RF AGC. When the wideband RF AGC operated, the S-meter signal was amplified causing incorrect stop operation. For example, modulation sidebands could stop the tuner one station too early.

The S-meter linearity has now been restricted to approximately 60 dBμ minimum during the seek and stop operations for LA1136N and LA1137N. When the RF AGC operates during seek operation, the S-meter signal amplifier is disabled. This reduces the potential for tuning error when using the stop detector method (such as LM7001, etc.).

Countermeasure for problem ③:

For LA1137N, a transistor and base current supply circuit (200 μA maximum) have been incorporated into a cascade AGC configuration to simplify the use of high I_{DSS} FETs. An external resistor is required.

Note that $V_{AGC-0} = 6.1$ V for no input signal. Also, V_{CC} should be chosen carefully since it affects both the dynamic range and the sensitivity.

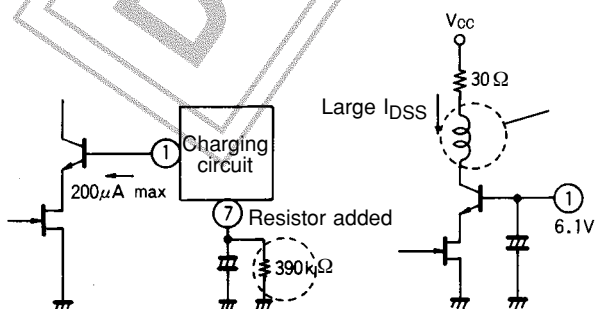

18. Gain Adjustment Method

(1) AGC Operations

The AGC circuits for LA1136N and LA1137N are configured based on the AGC circuit for LA1135. Although this explanation is for the LA1137N, it is identical for the LA1136N, except that the pin numbers are different.

① IF stage

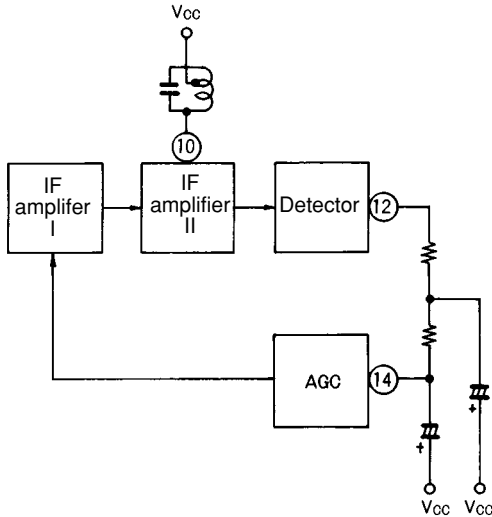
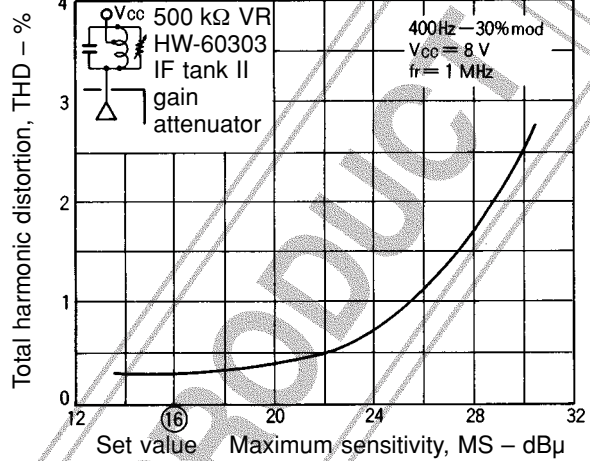

Figure 1 AGC gain and distortion characteristics



The IF stage block diagram is shown in the figure above. The output current from pin 12 is converted to a voltage and detected by pin 14 of the IF AGC circuit. IF Amplifier I prevents the input signal from exceeding the dynamic range of IF Amplifier II. The relationship between the gain and distortion of the IF stage is shown in Figure 1.

Note that when the gain is decreased, the AGC ON level is increased causing distortion at the IF Amplifier II input (At maximum sensitivity, the antenna input is increased at output -25 dBμ). This limits the effectiveness of using the IF tank II for decreasing gain.

② RF stage

The AGC for signal 1 of LA1137N operates as shown below.

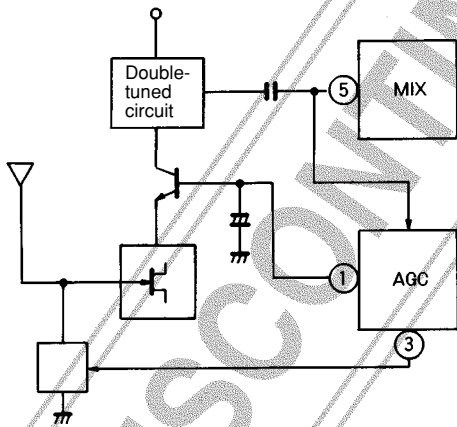
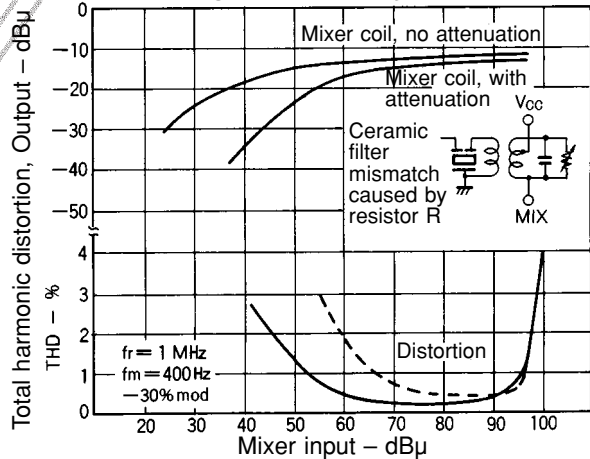

Figure 2 Gain adjustment



The RF AGC circuit reduces the voltage on pin 1 (6 V when no input) by detecting and amplifying the mixer input signal. When operating, the voltage drops to 3.5 V, approximately 6 mA of antenna dumping current is driven from Pin 3 to hold the antenna input signal constant. When current flows from Pin 3, the voltage on Pin 1 drops to 0.6 V min. to control the drain-to-source voltage of the input FET. Because the RF AGC operates independently of the gain of IF tank I, the RF AGC gain can be reduced without increasing distortion (See Figure 2).

LA1136N, 1136NM, 1137N, 1137NM

③ RF alignment coil

In general, the RF amplifier gain and fluctuations in the effective sensibility should be kept as low as possible.

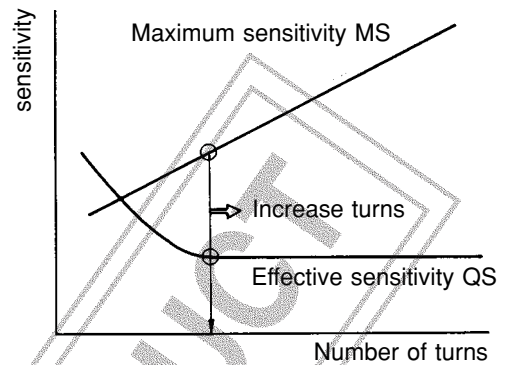
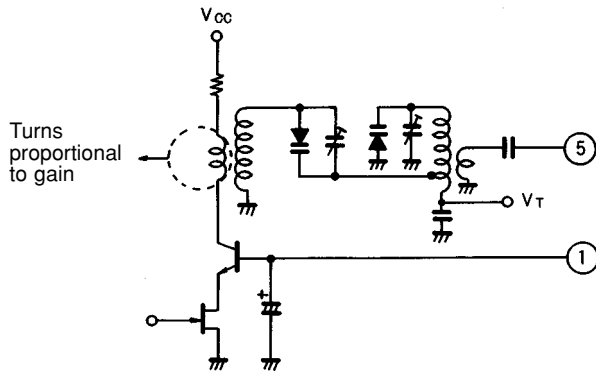

Check the data in the diagram to determine the number of turns.

19. IF Count Buffer

Although this explanation is for the LA1137N, it is identical for the LA1136N, except that the pin numbers are different.

Circuit operations

Pin 13 serves as both the count buffer input pin and output pin. When the control voltage with no load is HIGH 5 V, the IF buffer output is 300 mVrms and when LOW GND, 1 mVrms or lower. Supports Sanyo's LM7000 and LC7230.

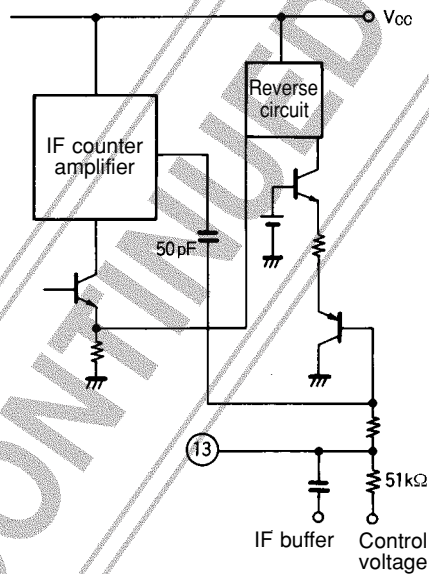

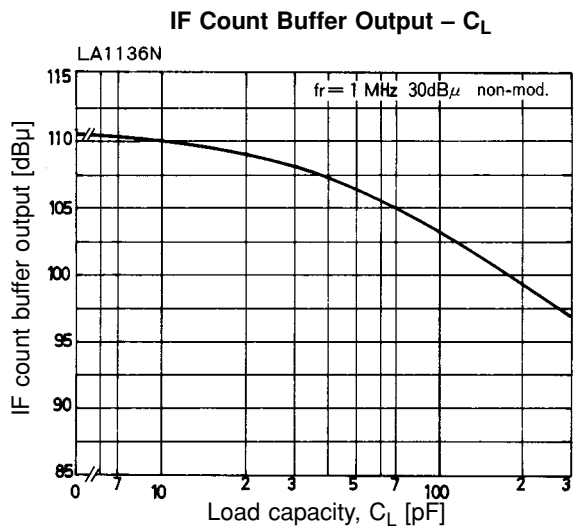
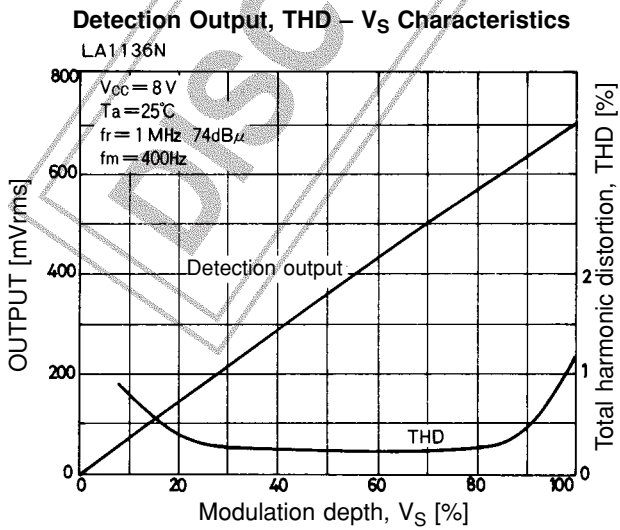
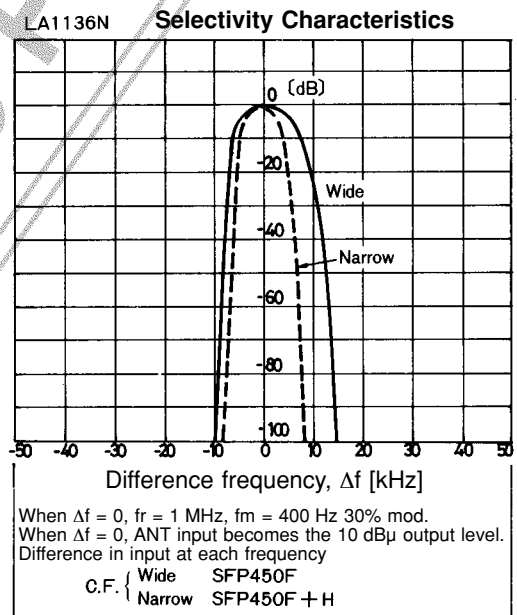
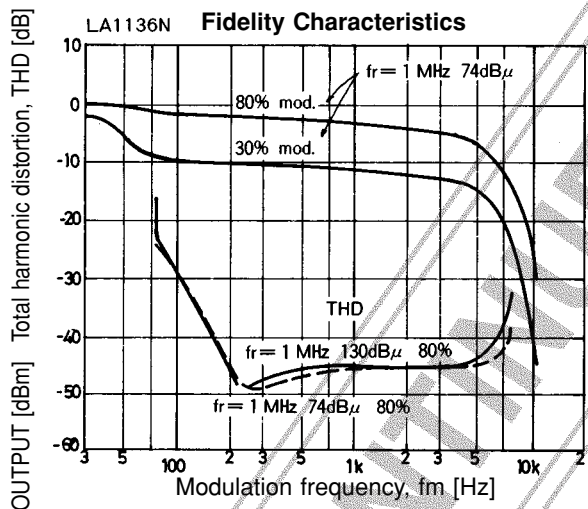
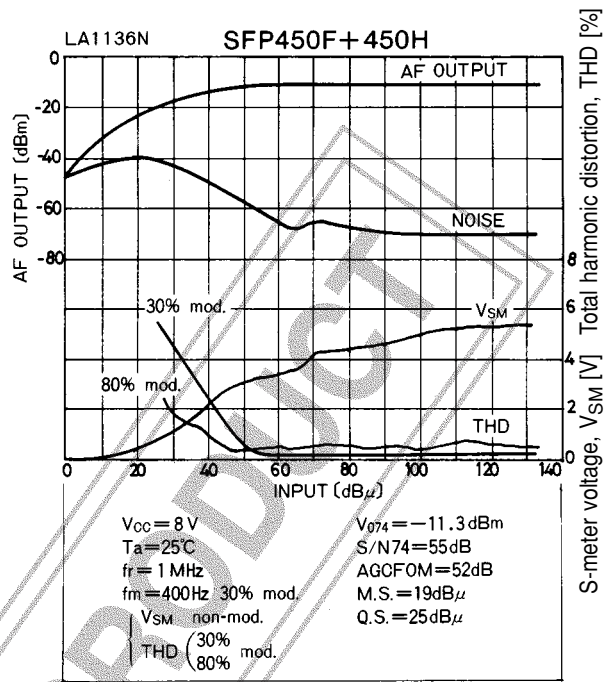
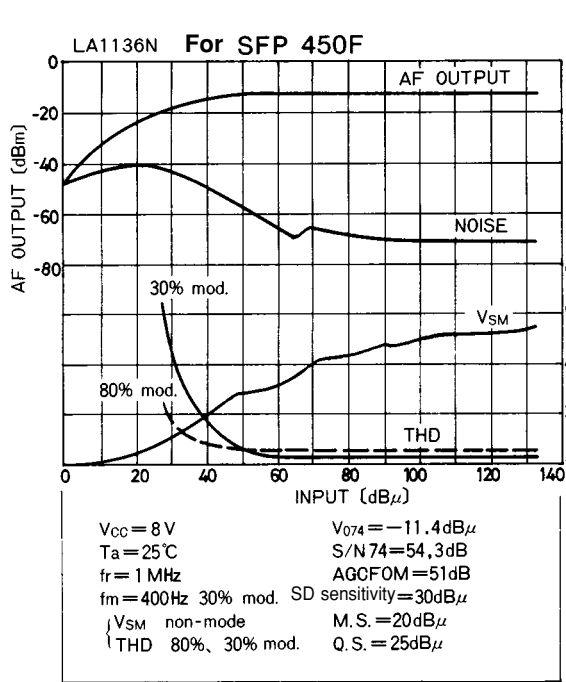

LA1136N, 1136NM, 1137N, 1137NM

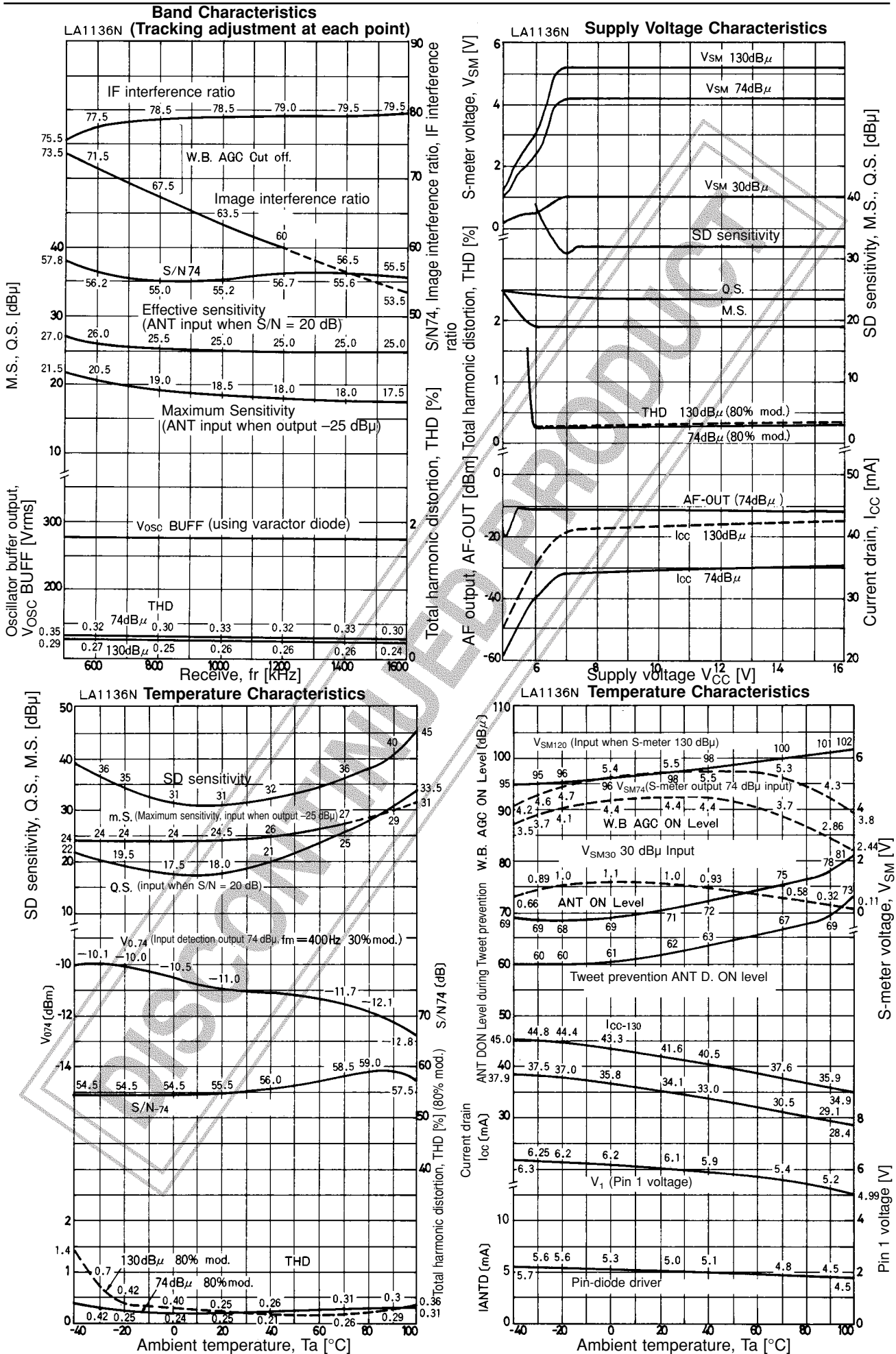

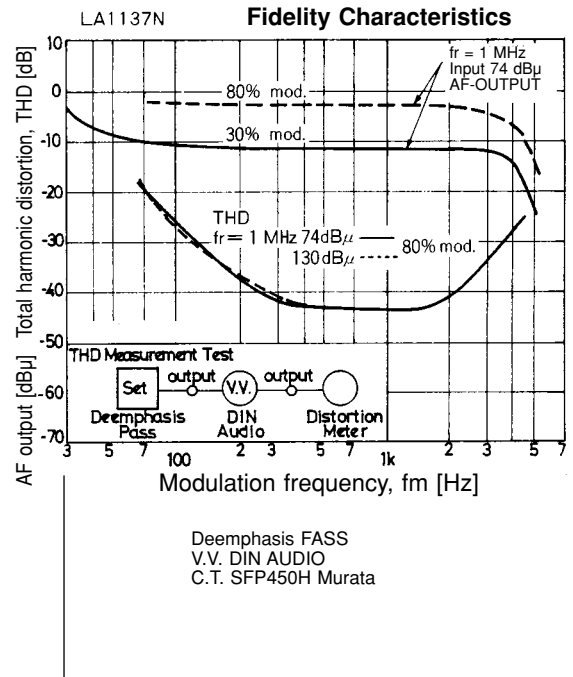
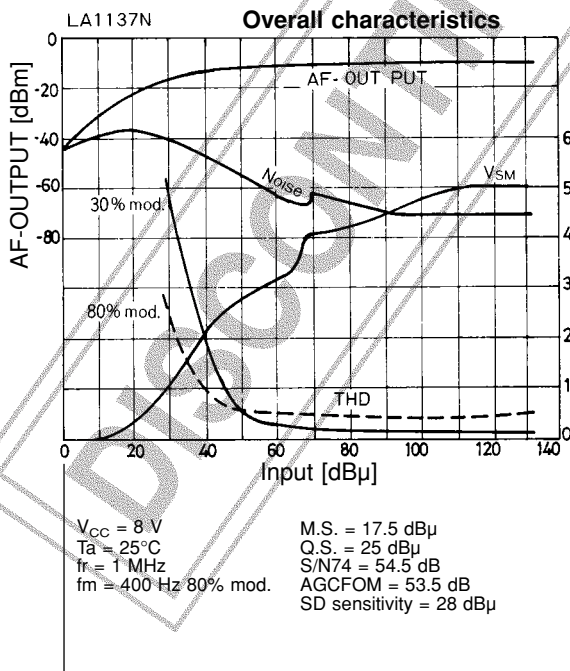
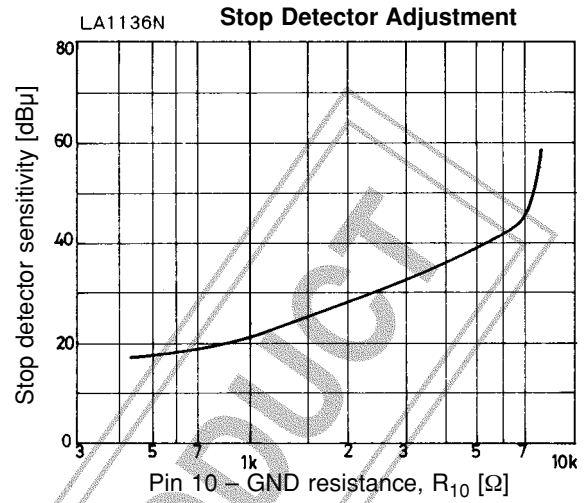
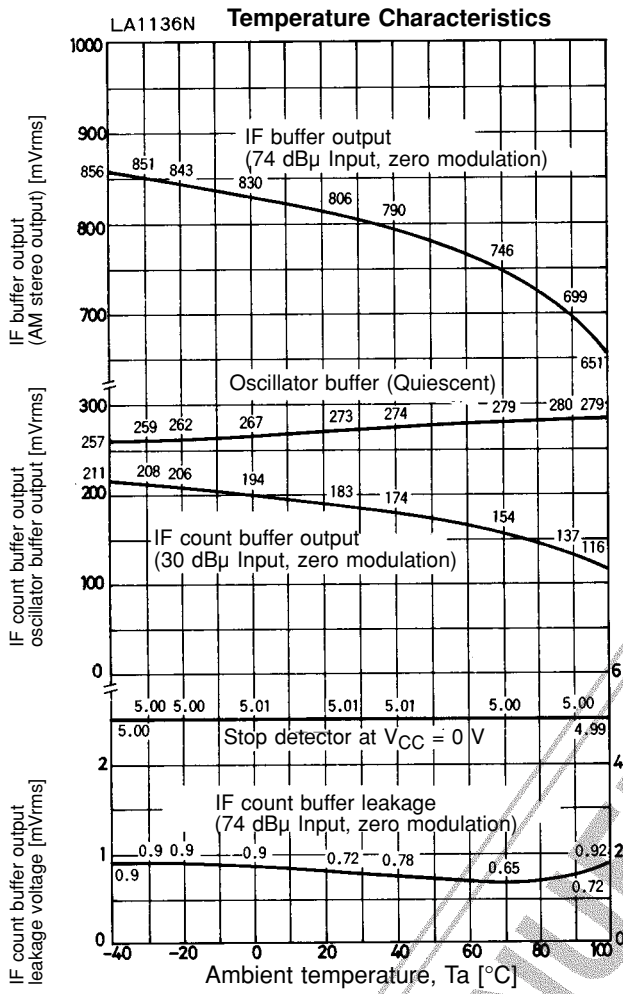

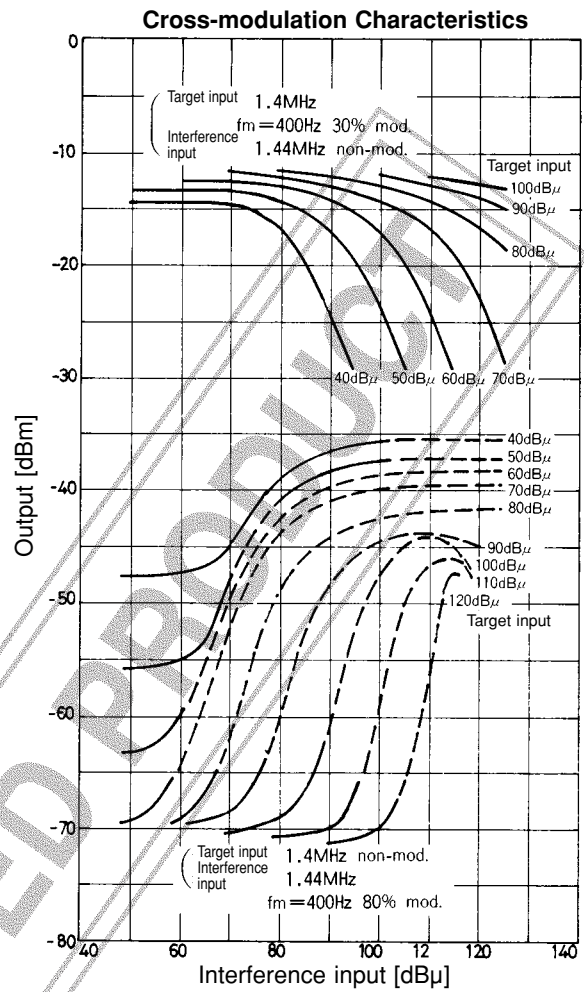
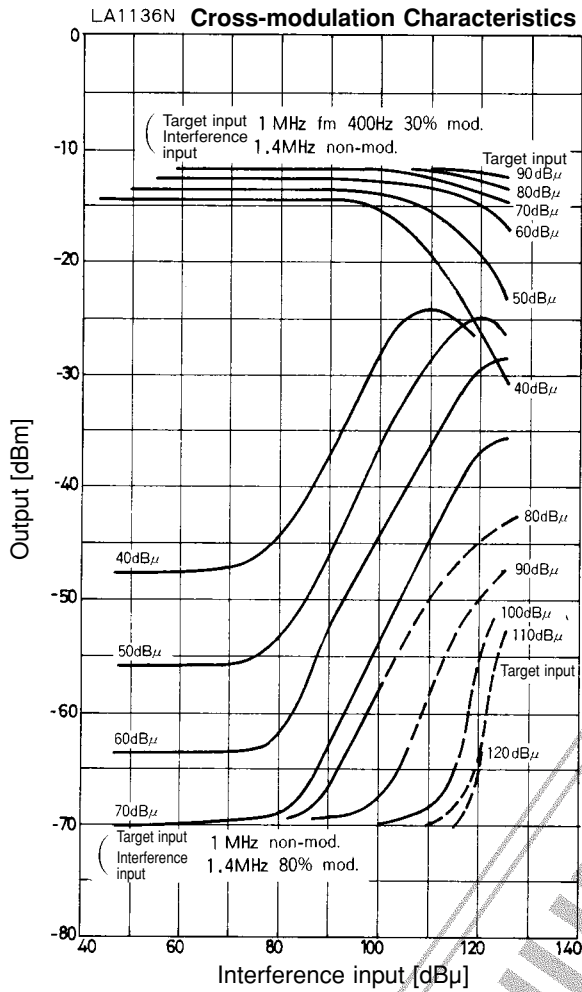

- No products described or contained herein are intended for use in surgical implants, life-support systems, aerospace equipment, nuclear power control systems, vehicles, disaster/crime-prevention equipment and the like, the failure of which may directly or indirectly cause injury, death or property loss.
- Anyone purchasing any products described or contained herein for an above-mentioned use shall:
 - ① Accept full responsibility and indemnify and defend SANYO ELECTRIC CO., LTD., its affiliates, subsidiaries and distributors and all their officers and employees, jointly and severally, against any and all claims and litigation and all damages, cost and expenses associated with such use:
 - ② Not impose any responsibility for any fault or negligence which may be cited in any such claim or litigation on SANYO ELECTRIC CO., LTD., its affiliates, subsidiaries and distributors or any of their officers and employees jointly or severally.
- Information (including circuit diagrams and circuit parameters) herein is for example only; it is not guaranteed for volume production. SANYO believes information herein is accurate and reliable, but no guarantees are made or implied regarding its use or any infringements of intellectual property rights or other rights of third parties.

This catalog provides information as of September, 1997. Specifications and information herein are subject to change without notice.