



050-352

PRODUCT BRIEF

10MBPS-200 MBPS

PRINTED CIRCUIT BOARD (PCB) MOUNT TRANSCEIVER

1310NM FP TRANSMITTER, PIN TIA RECEIVER

SMALL & COMPACT WITH RUGGED CONSTRUCTION FOR
HARSH ENVIRONMENTS

REV	DESCRIPTION	DATE	APPROVED
2	Preliminary	06/05/2015	SZ
3	Updated description on Pin Assignment Table	01/04/2016	SZ
4	Add ECCN	05/26/2016	RAS
5	Change PRBS Specification to 2 ⁷ -1	10/12/2016	SZ/GC
6	Replace "mm" with "um" on I2C table	11/11/2016	SZ/GC
7	Edit Bag and Tag Labeling	12/12/2016	RAS/GC
8	Remove incorrect reference to ATMEL AT240C01A, added optional I2C addressing	02/28/2017	RAS/GC
9	Corrected datasheet - removed Receiver power monitoring language	6/11/2018	RAS/SZ

BF15U2-2330

THIS COPYRIGHTED DOCUMENT IS THE PROPERTY OF GLENAIR, INC. AND IS FURNISHED ON THE CONDITION THAT IT IS NOT TO BE DISCLOSED, REPRODUCED IN WHOLE OR IN PART, OR USED TO SOLICIT QUOTATIONS FROM COMPETITIVE SOURCES, OR USED FOR MANUFACTURE BY ANYONE OTHER THAN GLENAIR, INC. WITHOUT WRITTEN PERMISSION FROM GLENAIR, INC. THE INFORMATION HEREIN HAS BEEN DEVELOPED AT GLENAIR'S EXPENSE AND MAY BE USED FOR ENGINEERING EVALUATION AND INCORPORATION INTO TECHNICAL SPECIFICATIONS AND OTHER DOCUMENTS WHICH SPECIFY PROCUREMENT OF PRODUCTS FROM GLENAIR, INC.

050-352 Product Brief
PCB Mount Transceiver
10 Mbps – 200 Mbps, SMF, 3.3V



PCB Mount Fiber Optic Transceiver, 10Mbps-200Mbps, SMF, 3.3V

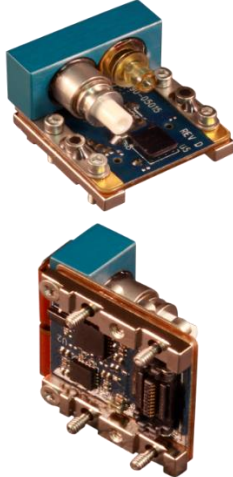

Glenair 050-352, is a ruggedized harsh environment PCB Mount Transceiver with electrical and optical functionality equivalent to SFP transceivers but with mechanical design that is suited to the harsh temperature and vibration environments found in Military, Aerospace, Railway, Oil and Gas, and Industrial applications. The PCB mount optical transceivers also support optional Digital Monitoring Interface (DMI) features in accordance with SFF 8472. The Transceiver is comprised of a transmitter section and a receiver section that resides on a common package and interface with a host board through a high speed electrical connector.

The transmitter section includes the Transmitter Optical Subassembly (TOSA) and Laser driver circuitry. The TOSA, containing a 1310nm FP laser is located at the optical interface and mates with the GC optical connector. The TOSA is driven by a laser driver, which converts differential logic signals into an analog drive current.

The receiver section includes the Receiver Optical Subassembly (ROSA) and amplification/quantization circuitry. The ROSA, containing a PIN photodiode and trans-impedance preamplifier, is located at the optical interface and mates with the GC optical connector. The ROSA is mated to a limiting amplifier IC that provides post-amplification and quantization. Also included is a Loss Of Signal (LOS) detection circuit.

KEY FEATURES/BENEFITS

- SFP Compatible Electrical I/O signal levels
- 1310nm FP laser to support up to 200Mbps
- PIN PD to support high sensitivity up to 200Mbps
- Glenair Rugged GC Optical connector
- High Operational Shock (650 g) & Vibration (54 g rms) – test reports available
- Transceiver is securely mounted with screws to PCB to ensure excellent shock and vibration performance
- High-Speed Electrical plug-in connector eliminates the need for soldering & enables ease of servicing
- Captive screws to simplify logistics and assembly
- Compact size: Approx 0.8" x 0.9" x 0.5"

- -40°C to +85°C Operating Case Temperature
- Glenair fiber jumpers connect from transceiver to any Glenair Mil/Aero Fiber Optic Connector Style
- Evaluation fixtures available
- Optional Digital Diagnostic and Monitoring (DMI) based on SFF-8472, enables monitoring of:
 - TX optical power, Laser bias current, Temperature, Supply voltage

APPLICATIONS

- Harsh Environment such as: Airborne, Tactical, Railway, Industrial, Oil and Gas and Shipboard applications
 - Ethernet, Fast Ethernet, FDDI

HOW TO ORDER Table 1 Part Number Development Options

Part Number	Two Wire Address	Data Rate	Temperature**	Screw Length** (Mod Code)
050-352	Blank = A2h	-1-D = 10 Mbps - 200 Mbps	Blank = Standard	Blank = Standard
PCB Mount Transceiver, SMF, 1310nm	Other Options: C0, C2, C4, C6, C8, CA, CC, CE, D0, D2, D4, D6, D8, DA, DC, DE			-954-xxx = IAW Mod Code 954 -954A-xxx = IAW Mod Code 954A

Example: **050-352C0-1-D**

PCB Mount Transceiver, SMF, 1310nm, Two Wire Address = C0h, Data Rate = 10 Mbps – 200 Mbps, Standard Temperature Range, Standard Screw Length

**Temperature and Screw Length Mod Codes will not be added onto Digital Memory ID (See Table 9)

050-352 Product Brief
PCB Mount Transceiver
10 Mbps – 200 Mbps, SMF, 3.3V



Ratings and Specifications

TABLE 2 ABSOLUTE MAXIMUM RATINGS

Parameter	Symbol	Min	Typ	Max	Units	Notes
Storage Temperature	T _s	-55		+100	°C	
Supply Voltage	V _{cc}	-0.4		3.8	V	V _{ccT} & V _{ccR} may not differ by more than 0.5V

TABLE 3 OPERATING CONDITIONS

Parameter	Symbol	Min	Typ	Max	Units	Notes
Operating Temperature, Case	T _{op}	-40		+85	°C	
Supply Voltage	V _{cc}	3.135	3.3	3.465	V	
Supply Current	I _{cc}		180	250	mA	Typical @ +85°C
Power Supply Noise (Peak-Peak)	V _{cc_ripple}			100	mV	

TABLE 4 ELECTRO-OPTICAL CHARACTERISTICS – TRANSMITTER (T_{OP} UNLESS NOTED OTHERWISE)

Parameter	Symbol	Min	Typ	Max	Units	Notes
Optical Output Power	P _{OUT}	-14		-4	dBm	1310nm FP, SMF
Extinction Ratio	E _r	8	10		dB	
Optical Wavelength	λ _{OUT}	1260	1300	1380	nm	
Spectral Width, rms	Δλ		4		nm	
Transmitter Differential Input Impedance	Z _{in}		100		Ohms	AC coupled Internally
Differential Input Voltage	V _{in_d}	250		2200	mV _{p-p}	LVPECL, 100 ohm

TABLE 5 ELECTRO-OPTICAL CHARACTERISTICS – RECEIVER (T_{OP} UNLESS NOTED OTHERWISE)

Parameter	Symbol	Min	Typ	Max	Units	Notes
Sensitivity, BER 10 ⁻¹⁰ , PRBS 2 ⁷ -1, E _r 10 dB	P _{IN}		-34	-32	dBm	PIN PD @ 125Mbps
Overload, BER 10 ⁻¹⁰ , PRBS 2 ⁷ -1	P _{IN}	-3			dBm	@125Mbps
Optical Wavelength	λ _{IN}	1100		1600	nm	
Receiver Differential Output Impedance	Z _{out}		100		Ohms	AC coupled internally
Differential Output Voltage Swing	V _{out_d}	400		2000	mV _{p-p}	LVPECL, 100 ohm
LOS Assert Level	LOS			-35	dBm	@ 125 Mbps
LOS Hysteresis	LOS _{HYS}	1.5	3		dB	@ 125 Mbps

**050-352 Product Brief
PCB Mount Transceiver
10 Mbps – 200 Mbps, SMF, 3.3V**



Ratings and Specifications (cont'd)

TABLE 6 COMPLIANCE SPECIFICATIONS

CHARACTERISTIC	Standard	Condition	Notes
Mechanical Shock	MIL-STD-810	Para. 516.6, proc. I, 650g	0.9 ms operating
Mechanical Vibration	MIL-STD-810	Para. 514.6, 40g rms	Random, operating
ESD	MIL-STD-883		1000V HBM
Flame Resistance	MIL-STD-1344	Method 1012, Cond. B	30 seconds
Altitude Altitude, 25Kft Altitude, 70Kft Decompression Overpressure	RTCA DO160 G	Section 4.6.1 Category B1 Section 4.6.1 Category E1 Section 4.6.2 Category A2 Section 4.6.3 Category A1	Operating Altitude, 25,000 ft Operating Altitude, 70,000 ft Operating Altitude, 45,000 ft 28 psia
Damp Heat	RTCA DO160G MIL-STD-1344	Section 6 Category A Method 1002.2, Cond. B	48 hours, Non-operational 10 cycles, 24 hours, Operational
Eye Safety	CDRH and IEC-825	Class 1 Laser Product	

TABLE 7 MATERIAL/FINISH

Item	Material/Finish
PCB	FR4
PCB flex	FR4 & Polyimide
Railings	Aluminum 6061-T6 per ASTM-B221/B211M or Equivalent
Screws	CRES Type, 302, 303, 304, 305, or 316
Optical Ferrules & Sleeves	Zirconia, Ceramic
Solder type	RoHS compliant Sn95/Sb5 (232°C melting temp) & RoHS compliant Sn96.5/Ag3.0/Cu0.5 (217° melting)

050-352 Product Brief
PCB Mount Transceiver
10 Mbps – 200 Mbps, SMF, 3.3V



FIGURE 1 - OUTLINE DRAWING CONTINUED (MARKING)

LABELING:

Each unit will be shipped in an antistatic bag. The label on the antistatic bag shall be at a minimum Arial size 10 black font and contain at a minimum the following information:

ANTISTATIC BAG LABEL:

Glenair

Cage Code: 06324

PN: 050-352XX-X-X

Rev: X

QTY: X

J/N: X

D/C: X

S/N*: XXXXXX

*If QTY is more than 1, there is no S/N

Each unit will be marked, either with a label or laser engraving, as follows:

- Marking font to be Arial, greater than .08 inches in height.
- Marking:
 - FIRST LINE OF TEXT
 - Glenair
 - Serial Number (6 digits)
 - SECOND LINE OF TEXT:
 - Part number

Example

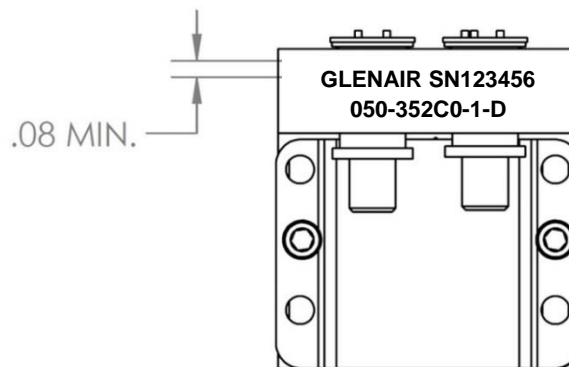

FUNCTIONAL DESCRIPTION

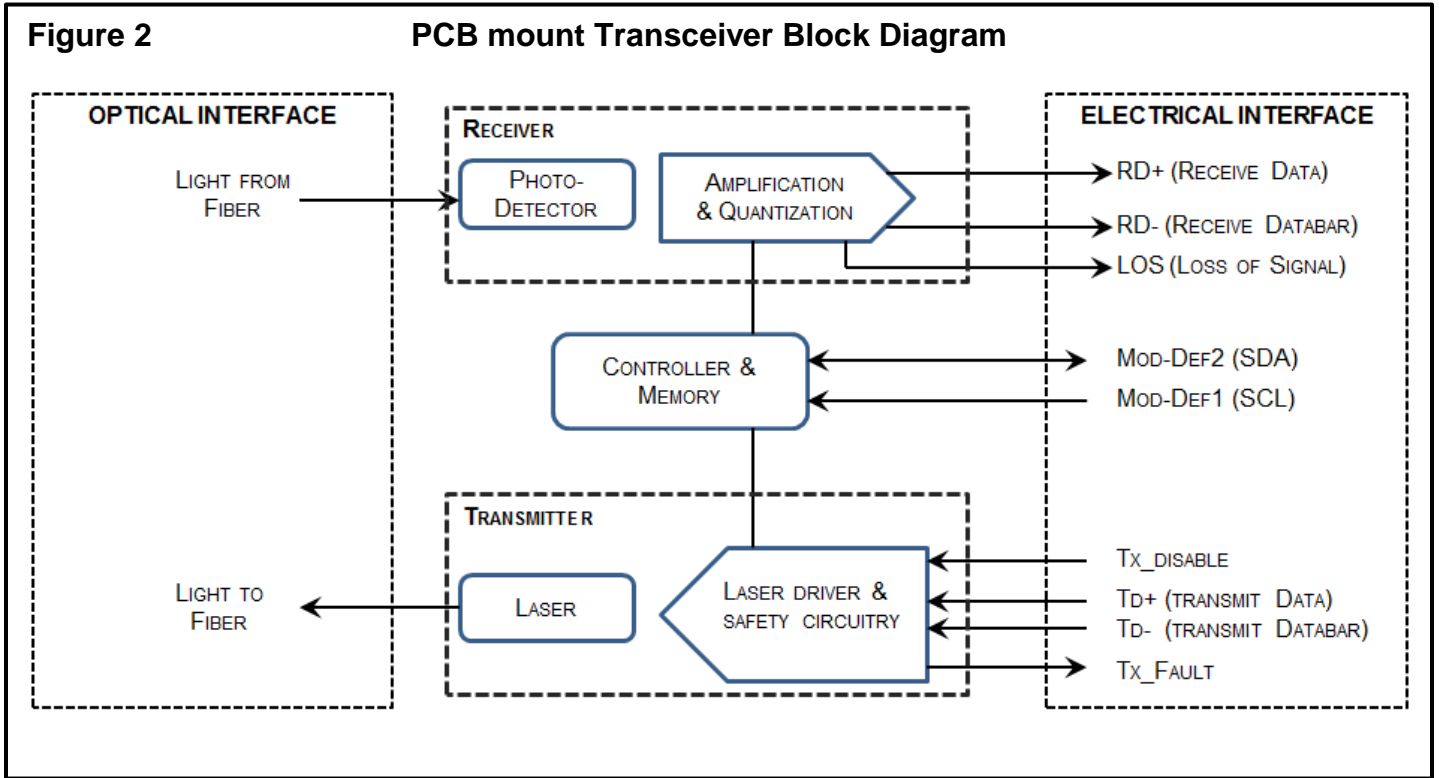

TRANSMITTER SECTION

Transmit Disable (TX_Disable, pin 10)

The transmitter section of the transceiver accepts a TTL and CMOS compatible transmit disable control signal input that shuts down the transmitter optical output. A high signal disables the transmitter while a low signal allows normal transceiver operation. Also Laser is disabled when TX Disable is open.

RECEIVER SECTION

Receiver Loss of Signal (LOS, Pin 20)

The Loss of Signal (LOS) output indicates an unusable optical input power level. The post-amplification IC includes transition detection circuitry which monitors the ac level of incoming optical signals and provides a TTL/CMOS compatible status signal to the host. A low LOS logic level indicates the presence of an optical input while a high LOS logic level indicates an unusable optical input. The LOS thresholds are factory-set so that a high output indicates a definite optical fault has occurred (e.g. failed transmitter, broken or disconnected fiber connection to the transceiver, etc.). The LOS can also be monitored via the 2-wire serial interface (address A2h, byte 110, bit 1).

**050-352 Product Brief
PCB Mount Transceiver
10 Mbps – 200 Mbps, SMF, 3.3V**



FUNCTIONAL I/O

The PCB Mount Transceiver accepts industry standard differential signals such as LVPECL within the scope of the SFP MSA. To simplify board requirements, transmitter bias resistors and ac coupling capacitors are incorporated, per SFF-8074i, and hence are not required on the host board. The module is AC-coupled and internally terminated.

Figure 3 illustrates a recommended interface circuit to link the PCB Mount Transceiver to the supporting Physical Layer integrated circuits.

The PCB Mount Transceiver interfaces with the host circuit board through twenty I/O pins identified by function in Table 8. The transceiver high speed transmit and receive interfaces requires SFP MSA compliant signal lines on the host board. The Tx_Disable and Rx_LOS lines require TTL lines on the host board (per SFF-8074i) if used. If an application chooses not to take advantage of the functionality of these pins, TX_Disable need to be tied to GND and RX_LOS does not need to be connected.

Digital Diagnostic Interface and Serial Identification (EEPROM)

The PCB Mount Transceiver is compatible with the SFF-8074i SFP specification and with SFF-8472, the SFP specification for Digital Diagnostic Monitoring Interface. Both specifications can be found at <http://www.sffcommittee.org>.

050-352 Product Brief
 PCB Mount Transceiver
 10 Mbps – 200 Mbps, SMF, 3.3V



FIGURE 3 RECOMMENDED PCB MOUNT TRANSCEIVER HOST BOARD SCHEMATIC

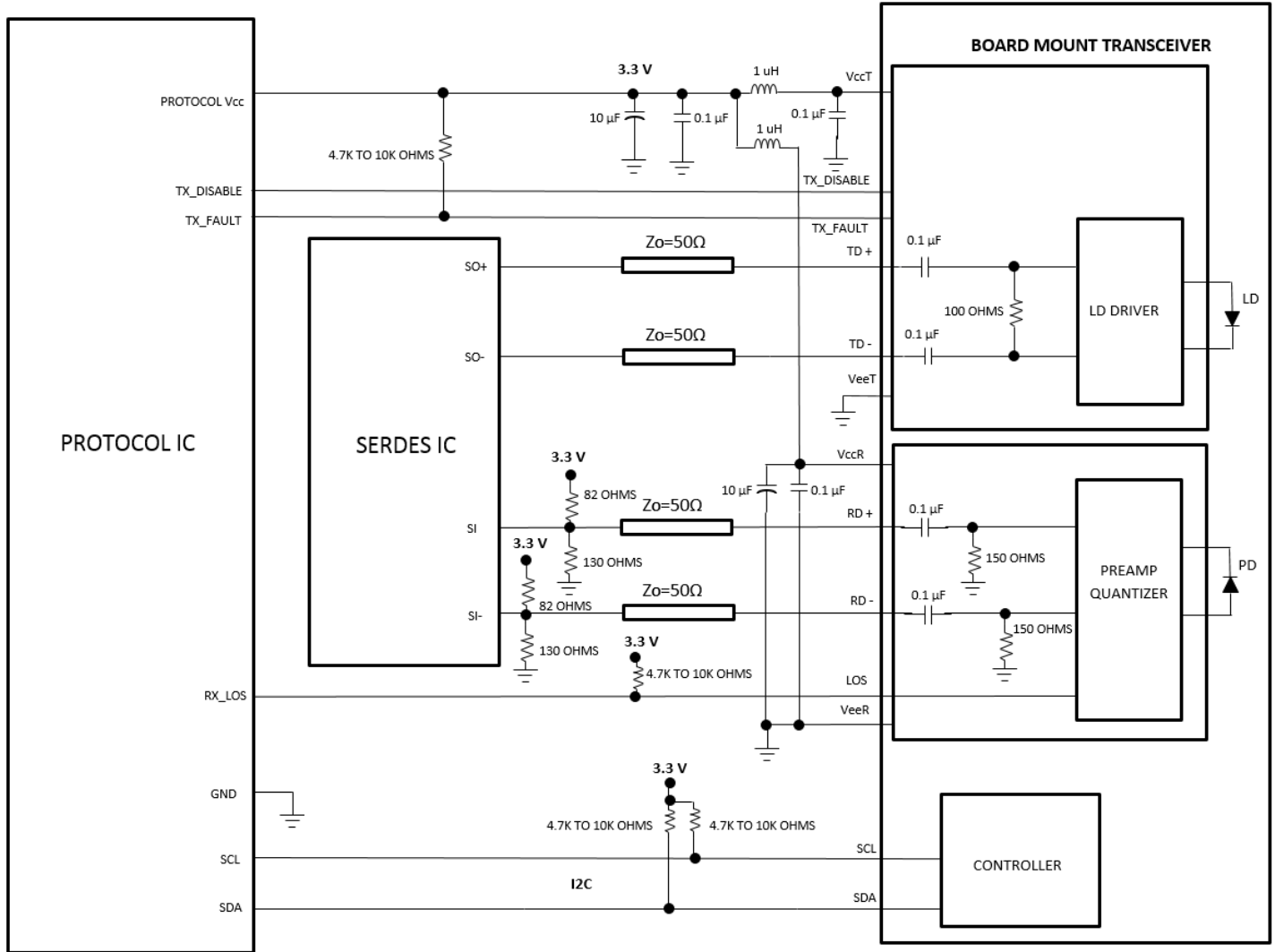

The PCB Mount Transceiver features EEPROM for Serial ID, which contains the product data stored for retrieval by host equipment. This data is accessed via the 2-wire serial EEPROM protocol in compliance with the industry standard SFP Multi-Source Agreement. The base EEPROM memory, bytes 0-255 at memory address 0xA0, is organized in compliance with SFF-8074i.

As an enhancement to the conventional SFP interface defined in SFF-8074i, the PCB Mount Transceiver is compliant to SFF-8472 (digital diagnostic interface for optical transceivers). This new digital diagnostic information is stored in bytes 0-255 at memory address 0xA2. Using the 2-wire serial interface defined in the MSA, the PCB Mount Transceiver provides real time temperature, supply voltage, Laser bias current and Transmitter output power. These parameters are internally calibrated, per the SFF-8472 MSA. The digital diagnostic interface also adds the capability to monitor for Receiver Loss

**050-352 Product Brief
PCB Mount Transceiver
10 Mbps – 200 Mbps, SMF, 3.3V**



of Signal (RX_LOS). The diagnostic information provides the opportunity for Predictive Failure Identification, Compliance Prediction, Fault Isolation and Component Monitoring.

Compliance Prediction

Compliance prediction is the ability to determine if an optical transceiver is operating within its operating and environmental requirements. The PCB Mount Transceiver provide real-time access to transceiver internal supply voltage and temperature, allowing a host to identify potential component compliance issues. Transmitter optical power can also be monitored through 2 wire serial interface. When operating out of requirements, the link cannot guarantee error free transmission.

Fault Isolation

The fault isolation feature allows a host to quickly pinpoint the location of a link failure, minimizing downtime. For optical links, the ability to identify a fault at a local device, remote device or cable plant is crucial to speeding service of an installation. PCB Mount Transceiver real-time monitors of Tx_Bias, Vcc, Temperature and Tx_Power can be used to assess local transceiver current operating conditions. In addition, status flag Rx Loss of Signal (LOS) is mirrored in memory and available via the two-wire serial interface.

Component Monitoring

Component evaluation is another use of the PCB Mount Transceiver real-time monitors of Tx_Bias, Vcc, Temperature and Tx_Power. Potential uses are as debugging aids for system installation and design, and transceiver parametric evaluation for factory or field qualification. For example, temperature per module can be observed in high density applications to facilitate thermal evaluation of systems that incorporate this PCB Mount Transceiver

Required Host Board Components

A power supply noise rejection filter as describe in SFP MSA is required on the host PCB to meet data sheet performance. This is filter incorporates an inductor which should be rated to 600 mADC and 0.5 Ω series resistance or better. It should not be replaced with a ferrite. The required filter is illustrated in Figure 4. Also, the host PCB for the PCB Mount Transceiver requires 4.7 K to 10 K Ω pull-up resistors for LOS, SCA and SDL lines.

FIGURE 4 RECOMMENDED HOST BOARD POWER SUPPLY FILTERING CIRCUIT

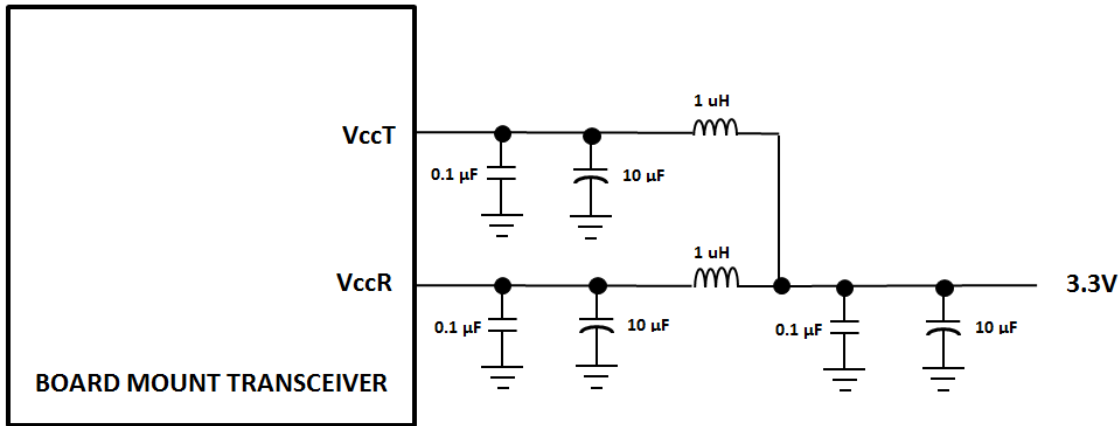

Fiber Compatibility

The transceiver is capable of transmission over link distance of 1 meter to 10 km of 9/125 μm fiber, at 125 Mbps Ethernet or FDDI data rates.

Electrostatic Discharge (ESD)

The Transceiver is compatible with ESD levels found in typical manufacturing and operating environments as described JEDEC EIA JESD22-A114, Class 1C (<2000Volts) HBM. Glenair recommends that devices are handled with ESD precautions to limit exposure to below 500V HBM.

There are two design cases in which immunity to ESD damage is important. The first case is during handling of the transceiver prior to insertion to the host board. To protect the transceiver, it's important to use standard industry ESD handling precautions. These precautions include using grounded wrist straps, work benches, and floor mats in ESD controlled areas. The ESD sensitivity of the Glenair PCB Mount Transceiver is compatible with typical industry production environments.

The second case to consider is static discharges to the exterior of the host equipment after installation, in which case the transceiver may be subject to system-level ESD requirements.

**050-352 Product Brief
PCB Mount Transceiver
10 Mbps – 200 Mbps, SMF, 3.3V**



Application Support

To assist in the transceiver design and evaluation process, Glenair offers the following aids:

- Evaluation board & Product Manual, part number 050-329, which facilitates in the testing of the PCB Mount Transceiver.
- 3D Step file to support modeling of mechanical fit and routing
- PADS schematic and PCB layout library files that can be exported into customer's PCB software design program
- Applications Aid Example of PCB layout including details of high speed transmission designs

Customer Manufacturing Processes

This module is mounted with screws and interfaces with a high-speed low cost surface mount electrical connector residing on the host PC board. The PCB Mount Transceiver is not designed for aqueous wash, IR reflow, or wave soldering processes and should be mounted on the host board after host PC board has been through these processes.

Proper torque values for mounting screws must be observed. Please contact Glenair for hardware mounting process recommendations.

050-352 Product Brief
PCB Mount Transceiver
10 Mbps – 200 Mbps, SMF, 3.3V



TABLE 9 TWO-WIRE INTERFACE ID: DATA FIELDS – ADDRESS A0h

Byte Decimal	# Hex	Data Notes	Byte Decimal	# Hex	Data Notes
0	80	Glenair PCB Mount Transceiver	37	00	Vendor OUI (NOT USED)
1	04	Serial ID Module Definition	38	00	Vendor OUI (NOT USED)
2	80	"GC" Fiber Optic Connector	39	00	Vendor OUI (NOT USED)
3	00		40	30	"0" Vendor Part Number ASCII Character (Note 5)
4	00		41	35	"5" Vendor Part Number ASCII Character (Note 5)
5	00		42	30	"0" Vendor Part Number ASCII Character (Note 5)
6	20	100BASE-FX	43	2D	"-" Vendor Part Number ASCII Character (Note 5)
7	00		44	33	"3" Vendor Part Number ASCII Character (Note 5)
8	00		45	35	"5" Vendor Part Number ASCII Character (Note 5)
9	00		46	32	"2" Vendor Part Number ASCII Character (Note 5)
10	00		47	43	"C" Vendor Part Number ASCII Character (Note 5)
11	01	Compatible with 8B/10B encoded data	48	30	"0" Vendor Part Number ASCII Character (Note 5)
12	01	BR, 100Mbps	49	2D	"-" Vendor Part Number ASCII Character (Note 5)
13	00		50	31	"1" Vendor Part Number ASCII Character (Note 5)
14	00		51	2D	"-" Vendor Part Number ASCII Character (Note 5)
15	64	10km of 9/125µm Fiber @ 125Mbps	52	44	"D" Vendor Part Number ASCII Character (Note 5)
16	00		53	20	" " Vendor Part Number ASCII Character (Note 5)
17	00		54	20	" " Vendor Part Number ASCII Character (Note 5)
18	00		55	20	" " Vendor Part Number ASCII Character (Note 5)
19	00		56	20	" " Vendor REV Level ASCII Character (Note 5)
20	47	"G" Vendor NAME ASCII Character	57	20	" " Vendor REV Level ASCII Character (Note 5)
21	4C	"L" Vendor NAME ASCII Character	58	20	" " Vendor REV Level ASCII Character (Note 5)
22	45	"E" Vendor NAME ASCII Character	59	20	" " Vendor REV Level ASCII Character (Note 5)
23	4E	"N" Vendor NAME ASCII Character	60	05	Hex Byte of Laser Wavelength (Note 6)
24	41	"A" Vendor NAME ASCII Character	61	14	Hex Byte of Laser Wavelength (Note 6)
25	49	"I" Vendor NAME ASCII Character	62		RESERVED
26	52	"R" Vendor NAME ASCII Character	63		Check sum code for ID fields 0-62 (Note 7)
27	20	" " Vendor NAME ASCII Character	64	00	
28	20	" " Vendor NAME ASCII Character	65	1A	Hardware TX_Disable & LOS
29	20	" " Vendor NAME ASCII Character	66	00	
30	20	" " Vendor NAME ASCII Character	67	00	
31	20	" " Vendor NAME ASCII Character	68-83		Serial Number, ASCII (Note 8)
32	20	" " Vendor NAME ASCII Character	84-91		Date Code (Note 9)
33	20	" " Vendor NAME ASCII Character	92	68	Diagnostic Monitoring Type
34	20	" " Vendor NAME ASCII Character	93	B0	Enhanced Options
35	20	" " Vendor NAME ASCII Character	94	05	SFF-8472 rev 11.0
36	00		95		Checksum for bytes 64-94 (Note 7)
			96-255	00	

Notes:

1. RESERVED
2. RESERVED
3. RESERVED
4. RESERVED
5. Table 1, Part number options/extensions. Temperature and Screw Length Mod Codes will not be added onto Digital Memory ID.
6. Laser wavelength is represented in 16 unsigned bits. The hex representation of 1300nm is 0514.
7. Addresses 63 and 95 are checksums calculated per SFF-8472 and SFF-8074, and stored prior to product shipment.
8. Addresses 68-83 specify the module's ASCII serial number and will vary by unit.
9. Addresses 84-91 specify the module's ASCII date code and will vary according to manufactured date-code.

050-352 Product Brief
PCB Mount Transceiver
10 Mbps – 200 Mbps, SMF, 3.3V



Table 10 Two-Wire interface ID: Data Fields – Address A2h is standard – other options available, see part number development

Byte # Decimal	Data Notes	Byte # Decimal	Data Notes	Byte # Decimal	Data Notes
0	Temp H Alarm MSB (Note 1)	26	TX Pwr L Alarm MSB (Note 4)	104	N/A
1	Temp H Alarm LSB (Note 1)	27	TX Pwr L Alarm LSB (Note 4)	105	N/A
2	Temp L Alarm MSB (Note 1)	28	TX Pwr H Warning MSB (Note 4)	106	Reserved
3	Temp L Alarm LSB (Note 1)	29	TX Pwr H Warning LSB (Note 4)	107	Reserved
4	Temp H Warning MSB (Note 1)	30	TX Pwr L Warning MSB (Note 4)	108	Reserved
5	Temp H Warning LSB (Note 1)	31	TX Pwr L Warning LSB (Note 4)	109	Reserved
6	Temp L Warning MSB (Note 1)	32	N/A	110	Status/Control
7	Temp L Warning LSB (Note 1)	33	N/A	111	Reserved
8	Vcc H Alarm MSB (Note 2)	34	N/A	112	Flag Bits
9	Vcc H Alarm LSB (Note 2)	35	N/A	113	Flag Bits
10	Vcc L Alarm MSB (Note 2)	36	N/A	114	Reserved
11	Vcc L Alarm LSB (Note 2)	37	N/A	115	Reserved
12	Vcc H Warning MSB (Note 2)	38	N/A	116	Flag Bits
13	Vcc H Warning LSB (Note 2)	39	N/A	117	Flag Bits
14	Vcc L Warning MSB (Note 2)	40-45	Reserved	118	Reserved
15	Vcc L Warning LSB (Note 2)	56-94	External Cal Constants (Note 4)	119	Reserved
16	Tx Bias H Alarm MSB (Note 3)	95	Checksum for bytes 0-94	120-122	Reserved
17	Tx Bias H Alarm LSB (Note 3)	96	Temperature MSB (Note 1)	123	Reserved
18	Tx Bias L Alarm MSB (Note 3)	97	Temperature LSB (Note 1)	124	Reserved
19	Tx Bias L Alarm LSB (Note 3)	98	Vcc MSB (Note 2)	125	Reserved
20	Tx Bias H Warning MSB (Note 3)	99	Vcc LSB (Note 2)	126	Reserved
21	Tx Bias H Warning LSB (Note 3)	100	TX Bias MSB (Note 3)	127	Reserved (Note 8)
22	Tx Bias L Warning MSB (Note 3)	101	TX Bias LSB (Note 3)	128-247	Customer Writable (Note 9)
23	Tx Bias L Warning LSB (Note 3)	102	TX Power MSB (Note 4)	248-255	Vendor Specific
24	TX Pwr H Alarm MSB (Note 4)	103	TX Power LSB (Note 4)		
25	TX Pwr H Alarm LSB (Note 4)				

Notes:

1. Temperature (Temp) is decoded as a 16 bit signed twos complement integer in increments of 1/256 °C.
2. Supply voltage (VCC) is decoded as a 16 bit unsigned integer in increments of 100 µV.
3. Laser bias current (Tx Bias) is decoded as a 16 bit unsigned integer in increments of 2 µA.
4. Transmitted average optical power (Tx Pwr) is not available
5. N/A
6. Bytes 55-94 are not intended for use but have been set to default values per SFF-8472.
7. Bytes 95 is a checksum calculated (per SFF-8472) and stored prior to product shipment.
8. Byte 127 accepts a write but performs no action (reserved legacy byte).
9. Bytes 128-247 are write enabled (customer writable).

050-352 Product Brief
PCB Mount Transceiver
10 Mbps – 200 Mbps, SMF, 3.3V



TABLE 11 TRANSCEIVER DIGITAL DIAGNOSTIC MONITOR CHARACTERISTICS (WHEN APPLICABLE)

PARAMETER	SYMBOL	MIN.	UNITS	NOTES
Transceiver Internal Temperature Accuracy	TINT	±3.0	°C	Temperature is measured internal to the transceiver and is valid from -40°C to +85 °C case temperature
Transceiver Internal Supply Voltage accuracy	VINT	±0.1	V	Supply voltage is measured internal to the transceiver and can, with less accuracy, be correlated to the voltage at the Vcc pin. Valid over 3.3V ±5%
Transmitter Laser DC Bias Current Accuracy	IINT	±10	%	
Transmitted Average Optical Output Power Accuracy	PT	±3.0	dB	Coupled into 9/125 mm SM fiber. Valid from -1dBm to -14dBm

050-352 Product Brief
PCB Mount Transceiver
10 Mbps – 200 Mbps, SMF, 3.3V



ACCESSORIES

Fiber Optic Jumper Cables to support connection to Mil/Aerospace Connectors

KEY FEATURES:

- Jumper cable between Glenair Transceiver (end A) and Mil/Aero Connector termini (End B)
- Offered with either Multimode or Single Mode fibers

FIGURE 5
Fiber Optic Jumper Cable Assembly (see separate Glenair sales drawing FA02454 for details)



PCB Threaded Inserts, PN 059-0007

KEY FEATURES

- Simplifies installation of PCB Mount Transceivers eliminating the need for washers and nuts
- Existing Options to support PCB thickness from 0.03" to 0.92"
- Can support thicker PCB if required

EVALUATION Boards, PN 050-329, include

- MANUAL with test block diagram, schematic
- Evaluation board PCBA
- 2 fiber optic cables (~1m, 9 μm/125 μm, GC connector to LC connector)

