

AMERICAN
TECHNICAL
CERAMICS

INDUCTOR PRODUCTS

Manufactured for ATC



 THE
ENGINEERS'
CHOICE®

CORPORATE PROFILE

Corporate Profile

ATC designs, develops, manufactures and markets Multilayer Capacitors, Single Layer Capacitors, Resistive Products, Inductors and Custom Thin Film Products for RF, microwave and millimeter-wave applications. Our products are primarily focused on the wireless communications infrastructure, fiber optic, medical electronics, semiconductor manufacturing equipment, defense, aerospace, and satellite communications markets. For over fifty years, ATC's family of superior component and custom integrated packaging solutions has been represented by **THE ENGINEERS' CHOICE™** brand.

Customer interface is administered by our own personnel and independent sales representatives. American Technical Ceramics is headquartered in Huntington Station, New York and has an Advanced Technology Center in Jacksonville, Florida. This is the center of excellence for our traditional product lines and the development and manufacturing facilities for Thin Film and Resistive Products.

American Technical Ceramics' Sales and Customer Service Center, serving Europe, Africa and the Middle East, is located in the Czech Republic. ATC has Regional Sales Offices in Surrey, England and Hallbergmoos, Germany. The Company's wholly-owned subsidiary offering Sales and Technical Support for Asia is located in Shenzhen, P.R. China.

American Technical Ceramics is a wholly-owned subsidiary of AVX Corp. The common stock of AVX is listed on the New York Stock Exchange (symbol "AVX").

RLC Product Offerings

- Multilayer Ceramic Capacitors
- Capacitor Assemblies for Power Applications
- Single Layer Ceramic Capacitors
- Resistor Products
- Inductor Products

Process and Packaging Offerings

- Thin Film Custom Products: metalization and patterned substrates for a broad range of hybrid circuit requirements

Markets Served

- Wireless Communications Infrastructure
- Semiconductor Manufacturing Equipment
- Medical Diagnostic Equipment
- Sattelite Systems
- Public Safety Radio
- Avionic Systems
- Military and Aerospace
- Commerical Broadcast Transmitters
- Fiber Optic Communications
- Automotive Electronics



▲ ATC's New York Facility occupies approximately 90,000 sq. ft.



▲ ATC's Jacksonville Facility occupies approximately 100,000 sq. ft.

Facilities

- **Huntington Station, New York** – Sales, Applications Support, Manufacturing and Distribution Center
- **Jacksonville, Florida** – Advanced Technology Center, Manufacturing Facility.

A M E R I C A N T E C H N I C A L C E R A M I C S

ATC North America
sales@atceramics.com

ATC Europe
sales@atceramics.com

ATC Asia
sales@atceramics-asia.com

www.atceramics.com

GENERAL SPECIFICATIONS

Introducing ATC's New WL Series, High Frequency Wire Wound Chip Inductors

ATC introduces its new family of RF surface mount inductor components, intended to complement its high frequency ultra low ESR capacitor products. The WL Series Wire Wound Chip Inductor Products have been designed to provide excellent performance at competitive prices.

This Series includes the most widely used traditional EIA case sizes – 0402, 0603, 0805, 1008, and 1206. The WL Inductor Product line is intended for RF and microwave applications and features high self-resonant frequencies (SRF), high Q, and low DC resistance. These products are manufactured on a rugged core made of high quality ceramic material that exhibits high Q at high operating frequencies.

The WL Series is especially attractive for all 800 MHz to 3.4 GHz wireless applications where cost and performance are major factors. These applications include but are not limited to: cellular base stations, broadband wireless services, point-to-point and point-to-multipoint radio as well as other RF and microwave telecommunications systems.

All WL Series Inductor Products are supplied in tape and reel (2000 to 4000 parts per reel depending on case size) as standard, making them ideal for automated pick and place manufacturing applications. The terminations consist of a barrier layer with a lead-free tin-plated finish that exhibits excellent solderability for trouble-free attachments.

Features

- High Q
- High SRF
- Low DC Resistance
- Wide Range of Standard EIA Inductance Values
1 nH to 15000 nH
- Traditional EIA Case Sizes 0402, 0603, 0805, 1008, and 1206
- Lead-Free, RoHS Compliant Terminations,
Tin Plated over Nickel Barrier
- Rugged Ceramic Core Construction
- Tape and Reel for Automated Placement

General Electrical Specifications:

- Inductance Range: 1 nH to 15000 nH, See Tables
- Operating Temperature: -40°C to +125°C
- Temperature Coefficient of Inductance (TCL):
+25 to +125 ppm/°C Typical From -40°C to +125°C
- Rated Current: See Tables, Pages 2-6
- SRF: See Tables, Pages 2-6
- IDC: See Tables, Pages 2-6
- RDC: See Tables, Pages 2-6

Applications:

- Cellular Base Station Equipment
- Broadband Wireless Services
- Point-to-Point and Point-to-Multipoint Radio
- Satcom Equipment
- Telecommunications Wireless Applications
- RF and Microwave Communications Systems

Circuit Applications:

- Amplifier Matching Networks
- Bias Networks
- Filters
- Oscillators
- Synthesizers

ATC 0402 WL SERIES WIRE WOUND CHIP INDUCTORS

| Inductance (nH) | Tolerance Code | Q min. | SRF (GHz) min. | RDC (Ohms) max. | IDC (mA) max. | 900 MHz | | 1.7 GHz | |
|-----------------|----------------|--------|----------------|-----------------|---------------|---------|--------|---------|--------|
| | | | | | | L typ. | Q typ. | L typ. | Q typ. |
| 1.0 @ 250 (MHz) | J, K | 16 | 12.7 | 0.045 | 1360 | 1.02 | 77 | 1.02 | 69 |
| 1.2 @ 250 (MHz) | J, K | 14 | 12.0 | 0.045 | 1360 | — | — | — | — |
| 1.8 @ 250 (MHz) | G, J, K | 16 | 11.3 | 0.07 | 1040 | 1.72 | 68 | 1.74 | 82 |
| 1.9 @ 250 (MHz) | J, K | 16 | 11.3 | 0.070 | 1040 | 1.72 | 68 | 1.74 | 82 |
| 2.0 @ 250 (MHz) | J, K | 16 | 11.1 | 0.070 | 1040 | 1.93 | 54 | 1.93 | 75 |
| 2.2 @ 250 (MHz) | J, K | 19 | 10.8 | 0.070 | 960 | 2.19 | 59 | 2.23 | 100 |
| 2.4 @ 250 (MHz) | J, K | 15 | 10.5 | 0.070 | 790 | 2.24 | 51 | 2.27 | 68 |
| 2.7 @ 250 (MHz) | J, K | 16 | 10.4 | 0.120 | 640 | 2.23 | 42 | 2.25 | 61 |
| 3.3 @ 250 (MHz) | G, J, K | 19 | 7.00 | 0.066 | 840 | 3.10 | 65 | 3.12 | 87 |
| 3.6 @ 250 (MHz) | G, J, K | 19 | 6.80 | 0.066 | 840 | 3.56 | 65 | 3.62 | 71 |
| 3.9 @ 250 (MHz) | G, J, K | 19 | 5.80 | 0.066 | 840 | 3.89 | 50 | 4.00 | 75 |
| 4.3 @ 250 (MHz) | G, J, K | 18 | 6.00 | 0.090 | 700 | 4.19 | 47 | 4.30 | 71 |
| 4.7 @ 250 (MHz) | G, J, K | 15 | 4.70 | 0.130 | 640 | 4.55 | 48 | 4.68 | 68 |
| 5.1 @ 250 (MHz) | G, J, K | 20 | 4.80 | 0.083 | 800 | 5.15 | 56 | 5.25 | 82 |
| 5.6 @ 250 (MHz) | G, J, K | 20 | 4.80 | 0.083 | 760 | 5.16 | 54 | 5.28 | 81 |
| 6.2 @ 250 (MHz) | G, J, K | 20 | 4.80 | 0.083 | 760 | 6.16 | 52 | 6.37 | 76 |
| 6.8 @ 250 (MHz) | G, J, K | 20 | 4.80 | 0.080 | 680 | 6.56 | 63 | 6.93 | 78 |
| 7.5 @ 250 (MHz) | G, J, K | 22 | 4.80 | 0.104 | 680 | 7.91 | 60 | 8.22 | 88 |
| 8.2 @ 250 (MHz) | G, J, K | 22 | 4.40 | 0.104 | 680 | 8.50 | 57 | 8.85 | 84 |
| 8.7 @ 250 (MHz) | G, J, K | 18 | 4.10 | 0.200 | 480 | 8.78 | 54 | 9.21 | 73 |
| 9.0 @ 250 (MHz) | G, J, K | 22 | 4.16 | 0.104 | 680 | 9.07 | 62 | 9.53 | 78 |
| 9.5 @ 250 (MHz) | G, J, K | 18 | 4.00 | 0.200 | 480 | 9.42 | 54 | 9.98 | 69 |
| 10 @ 250 (MHz) | G, J, K | 21 | 3.90 | 0.195 | 480 | 9.8 | 50 | 10.1 | 67 |
| 11 @ 250 (MHz) | G, J, K | 24 | 3.68 | 0.120 | 640 | 10.7 | 52 | 11.2 | 78 |
| 12 @ 250 (MHz) | G, J, K | 24 | 3.60 | 0.120 | 640 | 11.9 | 53 | 12.7 | 71 |
| 13 @ 250 (MHz) | G, J, K | 24 | 3.45 | 0.210 | 440 | 13.4 | 51 | 14.6 | 57 |
| 15 @ 250 (MHz) | G, J, K | 24 | 3.28 | 0.172 | 560 | 14.6 | 55 | 15.5 | 77 |
| 16 @ 250 (MHz) | G, J, K | 24 | 3.10 | 0.220 | 560 | 16.6 | 46 | 18.8 | 47 |
| 18 @ 250 (MHz) | G, J, K | 24 | 3.10 | 0.230 | 420 | 18.3 | 57 | 20.3 | 62 |
| 19 @ 250 (MHz) | G, J, K | 24 | 3.04 | 0.202 | 480 | 19.1 | 50 | 21.1 | 67 |
| 20 @ 250 (MHz) | G, J, K | 25 | 3.00 | 0.250 | 420 | 20.7 | 52 | 23.7 | 53 |
| 22 @ 250 (MHz) | G, J, K | 25 | 2.80 | 0.300 | 400 | 23.2 | 53 | 26.8 | 53 |
| 23 @ 250 (MHz) | G, J, K | 24 | 2.72 | 0.214 | 400 | 23.8 | 49 | 26.9 | 64 |
| 24 @ 250 (MHz) | G, J, K | 25 | 2.70 | 0.300 | 400 | 25.1 | 51 | 29.5 | 50 |
| 27 @ 250 (MHz) | G, J, K | 24 | 2.48 | 0.298 | 400 | 28.7 | 49 | 33.5 | 63 |
| 30 @ 250 (MHz) | G, J, K | 25 | 2.35 | 0.350 | 400 | 31.1 | 46 | 38.5 | 39 |
| 33 @ 250 (MHz) | G, J, K | 24 | 2.35 | 0.350 | 400 | 34.9 | 31 | 41.7 | 32 |
| 36 @ 250 (MHz) | G, J, K | 24 | 2.32 | 0.403 | 320 | 39.5 | 44 | 48.4 | 53 |
| 39 @ 250 (MHz) | G, J, K | 25 | 2.10 | 0.550 | 200 | 41.7 | 47 | 50.2 | 45 |
| 40 @ 250 (MHz) | G, J, K | 24 | 2.24 | 0.438 | 320 | 39.0 | 44 | 47.4 | 33 |
| 43 @ 250 (MHz) | G, J, K | 25 | 2.03 | 0.810 | 100 | 45.8 | 46 | 61.6 | 34 |
| 47 @ 250 (MHz) | G, J, K | 20 | 2.10 | 0.830 | 150 | 50.0 | 38 | 59.4 | 37 |
| 51 @ 250 (MHz) | G, J, K | 25 | 2.10 | 0.820 | 100 | 50.4 | 47 | 59.4 | 37 |
| 56 @ 250 (MHz) | G, J, K | 25 | 1.75 | 0.970 | 100 | 57.4 | 49 | 72.4 | 40 |
| 68 @ 250 (MHz) | G, J, K | 22 | 1.76 | 1.120 | 100 | 69.6 | 45 | 83.4 | 38 |
| 72 @ 250 (MHz) | G, J, K | 22 | 1.3 | 1.12 | 100 | — | — | — | — |
| 82 @ 250 (MHz) | G, J, K | 22 | 1.62 | 1.550 | 50 | — | — | — | — |
| 100 @ 250 (MHz) | G, J, K | 22 | 1.16 | 2.000 | 30 | — | — | — | — |
| 120 @ 250 (MHz) | G, J, K | 20 | 1.8 | 2.6 | 50 | — | — | — | — |

NOTE: For Mechanical Configurations, see page 7.

ATC Part Number Code

0402 WL 100 K T

EIA Case Size: 0402, 0603, 0805, 1008, 1206

Wire Wound Inductor

Inductance value in nH.
1st and 2nd digits are significant digits. 3rd digit is multiplier. R is decimal point.

The above part number refers to an ATC 0402 WL wire wound chip inductor, 10 nH, K (±10%) tolerance, in tape and reel packaging. Tighter tolerances are available. Consult factory.

Terminations for all WL Series Inductor Case Sizes are **Lead-Free, RoHS Compliant**, Tin Plated over Nickel Barrier.

Packaging: T - Tape & Reel

Tolerance: See table below.

| Inductance Tolerances | | | |
|-----------------------|------|------|-------|
| Code | G | J | K |
| Tol. | ± 2% | ± 5% | ± 10% |

Terminations

Terminations for all WL Series Inductor Case Sizes are **Lead-Free, RoHS Compliant**, Tin Plated over Nickel Barrier.

A M E R I C A N T E C H N I C A L C E R A M I C S

ATC North America
sales@atceramics.com

ATC Europe
sales@atceramics.com

ATC Asia
sales@atceramics-asia.com

ATC 0603 WL SERIES WIRE WOUND CHIP INDUCTORS

| Inductance (nH) | Tolerance Code | Q min. | SRF (MHz) min. | RDC (Ohms) max. | IDC (mA) max. | 900 MHz | | 1.7 GHz | |
|-----------------|----------------|--------|----------------|-----------------|---------------|---------|--------|---------|--------|
| | | | | | | L typ. | Q typ. | L typ. | Q typ. |
| 1.6 @ 250 (MHz) | J, K | 16 | 12,500 | 0.040 | 700 | 1.53 | 35 | 1.58 | 55 |
| 1.8 @ 250 (MHz) | J, K | 16 | 12,500 | 0.045 | 700 | 1.63 | 35 | 1.66 | 50 |
| 2.2 @ 250 (MHz) | J, K | 15 | 6000 | 0.100 | 700 | 2.18 | 41 | 2.20 | 64 |
| 2.3 @ 250 (MHz) | J, K | 16 | >4000 | 0.140 | 700 | 2.32 | 32 | 2.35 | 40 |
| 3.3 @ 250 (MHz) | G, J, K | 22 | 6000 | 0.080 | 700 | 3.35 | 47 | 3.40 | 65 |
| 3.6 @ 250 (MHz) | G, J, K | 22 | 5900 | 0.063 | 700 | 3.72 | 53 | 3.71 | 65 |
| 3.9 @ 250 (MHz) | G, J, K | 22 | 6900 | 0.080 | 700 | 3.95 | 49 | 3.96 | 67 |
| 4.3 @ 250 (MHz) | G, J, K | 22 | 5900 | 0.063 | 700 | 4.32 | 50 | 4.33 | 70 |
| 4.5 @ 250 (MHz) | G, J, K | 20 | 5800 | 0.120 | 700 | 4.74 | 55 | 4.87 | 92 |
| 4.7 @ 250 (MHz) | G, J, K | 20 | 5800 | 0.116 | 700 | 4.72 | 47 | 4.75 | 57 |
| 5.1 @ 250 (MHz) | G, J, K | 20 | 5700 | 0.140 | 700 | 4.93 | 47 | 4.95 | 56 |
| 5.6 @ 250 (MHz) | G, J, K | 20 | 5800 | 0.170 | 700 | 5.53 | 56 | 5.86 | 77 |
| 6.2 @ 250 (MHz) | G, J, K | 25 | 5800 | 0.110 | 700 | 6.28 | 60 | 6.40 | 85 |
| 6.3 @ 250 (MHz) | G, J, K | 25 | 5800 | 0.110 | 700 | 6.67 | 41 | 6.86 | 61 |
| 6.8 @ 250 (MHz) | G, J, K | 27 | 5800 | 0.110 | 700 | 6.75 | 60 | 7.10 | 81 |
| 7.5 @ 250 (MHz) | G, J, K | 28 | 4800 | 0.106 | 700 | 7.70 | 60 | 7.82 | 65 |
| 8.2 @ 250 (MHz) | G, J, K | 28 | 4700 | 0.109 | 700 | 8.30 | 60 | 8.50 | 60 |
| 8.7 @ 250 (MHz) | G, J, K | 28 | 4600 | 0.109 | 700 | 8.86 | 62 | 9.32 | 58 |
| 9.1 @ 250 (MHz) | G, J, K | 35 | 4800 | 0.130 | 700 | 9.20 | 70 | 9.70 | 80 |
| 9.5 @ 250 (MHz) | G, J, K | 28 | 5400 | 0.135 | 700 | 9.70 | 59 | 9.92 | 61 |
| 10 @ 250 (MHz) | G, J, K | 31 | 4800 | 0.130 | 700 | 10.00 | 66 | 10.60 | 83 |
| 11 @ 250 (MHz) | G, J, K | 33 | 4000 | 0.086 | 700 | 11.00 | 53 | 11.50 | 5 |
| 12 @ 250 (MHz) | G, J, K | 35 | 4000 | 0.130 | 700 | 12.30 | 72 | 13.50 | 83 |
| 15 @ 250 (MHz) | G, J, K | 35 | 4000 | 0.170 | 700 | 15.40 | 64 | 16.80 | 89 |
| 16 @ 250 (MHz) | G, J, K | 34 | 3300 | 0.104 | 700 | 16.20 | 55 | 17.30 | 52 |
| 17 @ 250 (MHz) | G, J, K | 35 | 3200 | 0.170 | 700 | 17.60 | 56 | 19.40 | 44 |
| 18 @ 250 (MHz) | G, J, K | 35 | 3100 | 0.170 | 700 | 18.70 | 70 | 21.40 | 69 |
| 20 @ 250 (MHz) | G, J, K | 40 | 3000 | 0.190 | 700 | 20.70 | 80 | 23.50 | 30 |
| 22 @ 250 (MHz) | G, J, K | 38 | 3000 | 0.190 | 700 | 22.80 | 73 | 26.10 | 71 |
| 23 @ 250 (MHz) | G, J, K | 38 | 2850 | 0.190 | 700 | 24.10 | 71 | 28.00 | 71 |
| 24 @ 250 (MHz) | G, J, K | 37 | 2650 | 0.135 | 700 | 24.50 | 45 | 28.70 | 39 |
| 27 @ 250 (MHz) | G, J, K | 40 | 2800 | 0.220 | 600 | 29.20 | 74 | 34.60 | 65 |
| 30 @ 250 (MHz) | G, J, K | 37 | 2250 | 0.144 | 600 | 31.40 | 47 | 39.90 | 28 |
| 33 @ 250 (MHz) | G, J, K | 40 | 2300 | 0.220 | 600 | 36.00 | 67 | 49.50 | 42 |
| 36 @ 250 (MHz) | G, J, K | 38 | 2080 | 0.250 | 600 | 39.40 | 47 | 52.70 | 24 |
| 39 @ 250 (MHz) | G, J, K | 40 | 2200 | 0.250 | 600 | 42.70 | 60 | 60.20 | 40 |
| 43 @ 250 (MHz) | G, J, K | 39 | 2000 | 0.280 | 600 | 47.00 | 44 | 64.90 | 21 |
| 47 @ 200 (MHz) | G, J, K | 38 | 2000 | 0.280 | 600 | 52.20 | 62 | 77.20 | 35 |
| 51 @ 200 (MHz) | G, J, K | 38 | 1900 | 0.280 | 600 | 55.50 | 69 | 82.20 | 34 |
| 56 @ 200 (MHz) | G, J, K | 38 | 1900 | 0.310 | 600 | 62.50 | 56 | 97.00 | 26 |
| 62 @ 200 (MHz) | G, J, K | 37 | 1800 | 0.340 | 600 | 68.00 | 40 | 110.00 | 10 |
| 68 @ 200 (MHz) | G, J, K | 37 | 1700 | 0.340 | 600 | 80.50 | 54 | 168.00 | 21 |
| 72 @ 150 (MHz) | G, J, K | 34 | 1700 | 0.490 | 400 | 82.00 | 53 | 135.00 | 20 |
| 82 @ 150 (MHz) | G, J, K | 34 | 1700 | 0.540 | 400 | 96.20 | 54 | 177.00 | 21 |
| 91 @ 150 (MHz) | G, J, K | 30 | 1700 | 0.500 | 400 | 110.00 | 50 | 416.40 | 6 |
| 100 @ 150 (MHz) | G, J, K | 34 | 1400 | 0.580 | 400 | 124.00 | 49 | 319.50 | 13 |
| 110 @ 150 (MHz) | G, J, K | 32 | 1350 | 0.610 | 300 | 138.00 | 43 | 342.70 | 15 |
| 120 @ 150 (MHz) | G, J, K | 32 | 1300 | 0.650 | 300 | 166.00 | 39 | 529.30 | 8 |
| 130 @ 150 (MHz) | G, J, K | 30 | 1400 | 0.720 | 300 | 185.00 | 60 | - | - |
| 140 @ 100 (MHz) | G, J, K | 28 | 1300 | 0.870 | 280 | 190.00 | 80 | - | - |
| 150 @ 150 (MHz) | G, J, K | 32 | 1300 | 0.950 | 280 | 230.00 | 25 | - | - |
| 160 @ 100 (MHz) | G, J, K | 25 | 1300 | 1.400 | 280 | 215.00 | 20 | - | - |
| 180 @ 100 (MHz) | G, J, K | 25 | 1250 | 1.400 | 250 | 303.00 | 20 | - | - |
| 220 @ 100 (MHz) | G, J, K | 25 | 1200 | 1.600 | 250 | 440.00 | 15 | - | - |
| 240 @ 100 (MHz) | G, J, K | 38 | 2.8 | 0.13 | 700 | 25.7 | 45 | 30.9 | 40 |
| 260 @ 100 (MHz) | G, J, K | 25 | 1000 | 2.000 | 200 | 469.00 | 21 | - | - |
| 270 @ 100 (MHz) | G, J, K | 25 | 900 | 2.100 | 200 | 580.00 | 12 | - | - |
| 280 @ 100 (MHz) | G, J, K | 25 | 900 | 2.400 | 100 | 524.00 | 18 | - | - |
| 300 @ 100 (MHz) | G, J, K | 25 | 750 | 2.500 | 150 | 539.70 | 21 | - | - |
| 330 @ 100 (MHz) | G, J, K | 25 | 900 | 3.800 | 100 | 440.00 | 15 | - | - |
| 390 @ 100 (MHz) | G, J, K | 25 | 900 | 4.350 | 100 | 580.00 | 12 | - | - |
| 470 @ 100 (MHz) | G, J, K | 23 | 600 | 3.600 | 80 | - | - | - | - |

NOTE: For Mechanical Configurations, see page 7.

ATC Part Number Code

0603 WL 100 J T

EIA Case Size: 0402, 0603, 0805, 1008, 1206

Wire Wound Inductor

Inductance value in nH.
1st and 2nd digits are significant digits. 3rd digit is multiplier. R is decimal point.
The above part number refers to an ATC 0603 WL wire wound chip inductor, 10 nH, J (±5%) tolerance, in tape and reel packaging.
Tighter tolerances are available. Consult factory.

Terminations for all WL Series Inductor Case Sizes are **Lead-Free, RoHS Compliant, Tin Plated over Nickel Barrier.**

Packaging: T - Tape & Reel
Tolerance: See table below.

| Inductance Tolerances | | | |
|-----------------------|------|------|-------|
| Code | G | J | K |
| Tol. | ± 2% | ± 5% | ± 10% |

A M E R I C A N T E C H N I C A L C E R A M I C S

ATC North America
sales@atceramics.com

ATC Europe
sales@atceramics.com

ATC Asia
sales@atceramics-asia.com

ATC 0805 WL SERIES WIRE WOUND CHIP INDUCTORS

| Inductance (nH) | Tolerance Code | Q (MHz) | SRF (MHz) | RDC (Ohms) | | IDC (mA) |
|------------------|----------------|-----------|-----------|------------|------|----------|
| | | min. | min. | max. | max. | |
| 2.7 @ 250 (MHz) | J, K | 80 @ 1500 | 7900 | 0.060 | 800 | |
| 2.8 @ 250 (MHz) | J, K | 80 @ 1500 | 7900 | 0.060 | 800 | |
| 3.0 @ 250 (MHz) | J, K | 65 @ 1500 | 7900 | 0.060 | 800 | |
| 3.3 @ 250 (MHz) | J, K | 50 @ 1500 | 7900 | 0.080 | 600 | |
| 5.6 @ 250 (MHz) | J, K | 65 @ 1500 | 5500 | 0.080 | 600 | |
| 6.2 @ 250 (MHz) | J, K | 50 @ 1000 | 5500 | 0.110 | 600 | |
| 6.8 @ 250 (MHz) | J, K | 50 @ 1000 | 5500 | 0.110 | 600 | |
| 7.5 @ 250 (MHz) | J, K | 50 @ 1000 | 4500 | 0.140 | 600 | |
| 8.2 @ 250 (MHz) | J, K | 50 @ 1000 | 4700 | 0.120 | 600 | |
| 8.7 @ 250 (MHz) | J, K | 50 @ 1000 | 3900 | 0.210 | 400 | |
| 10 @ 250 (MHz) | G, J, K | 60 @ 500 | 4200 | 0.100 | 600 | |
| 12 @ 250 (MHz) | G, J, K | 50 @ 500 | 4000 | 0.150 | 600 | |
| 15 @ 250 (MHz) | G, J, K | 50 @ 500 | 3400 | 0.170 | 600 | |
| 18 @ 250 (MHz) | G, J, K | 50 @ 500 | 3300 | 0.200 | 600 | |
| 22 @ 250 (MHz) | G, J, K | 55 @ 500 | 2600 | 0.220 | 500 | |
| 24 @ 250 (MHz) | G, J, K | 50 @ 500 | 2000 | 0.220 | 500 | |
| 27 @ 250 (MHz) | G, J, K | 55 @ 500 | 2500 | 0.250 | 500 | |
| 30 @ 250 (MHz) | G, J, K | 55 @ 500 | 2000 | 0.260 | 500 | |
| 33 @ 250 (MHz) | G, J, K | 60 @ 500 | 2050 | 0.270 | 500 | |
| 36 @ 250 (MHz) | G, J, K | 55 @ 500 | 1700 | 0.270 | 500 | |
| 39 @ 250 (MHz) | G, J, K | 60 @ 500 | 2000 | 0.290 | 500 | |
| 43 @ 200 (MHz) | G, J, K | 60 @ 500 | 1650 | 0.340 | 500 | |
| 47 @ 200 (MHz) | G, J, K | 60 @ 500 | 1650 | 0.310 | 500 | |
| 56 @ 200 (MHz) | G, J, K | 60 @ 500 | 1550 | 0.340 | 500 | |
| 68 @ 200 (MHz) | G, J, K | 60 @ 500 | 1450 | 0.380 | 500 | |
| 72 @ 150 (MHz) | G, J, K | 65 @ 500 | 1400 | 0.400 | 500 | |
| 82 @ 150 (MHz) | G, J, K | 65 @ 500 | 1300 | 0.420 | 400 | |
| 91 @ 150 (MHz) | G, J, K | 65 @ 500 | 1200 | 0.480 | 400 | |
| 100 @ 150 (MHz) | G, J, K | 65 @ 500 | 1200 | 0.460 | 400 | |
| 110 @ 150 (MHz) | G, J, K | 50 @ 250 | 1000 | 0.480 | 400 | |
| 120 @ 150 (MHz) | G, J, K | 50 @ 250 | 1100 | 0.510 | 400 | |
| 150 @ 100 (MHz) | G, J, K | 50 @ 250 | 920 | 0.560 | 400 | |
| 180 @ 100 (MHz) | G, J, K | 50 @ 250 | 870 | 0.640 | 400 | |
| 200 @ 100 (MHz) | G, J, K | 50 @ 250 | 860 | 0.660 | 400 | |
| 220 @ 100 (MHz) | G, J, K | 50 @ 250 | 850 | 0.700 | 400 | |
| 240 @ 100 (MHz) | G, J, K | 44 @ 250 | 690 | 1.000 | 350 | |
| 250 @ 100 (MHz) | G, J, K | 45 @ 250 | 680 | 1.000 | 350 | |
| 270 @ 100 (MHz) | G, J, K | 48 @ 250 | 650 | 1.300 | 350 | |
| 300 @ 100 (MHz) | G, J, K | 48 @ 250 | 620 | 1.200 | 330 | |
| 330 @ 100 (MHz) | G, J, K | 48 @ 250 | 600 | 1.650 | 310 | |
| 360 @ 100 (MHz) | G, J, K | 48 @ 250 | 580 | 1.450 | 300 | |
| 390 @ 100 (MHz) | G, J, K | 48 @ 250 | 560 | 1.800 | 290 | |
| 430 @ 50 (MHz) | G, J, K | 33 @ 100 | 430 | 1.700 | 230 | |
| 470 @ 50 (MHz) | G, J, K | 22 @ 100 | 375 | 2.000 | 250 | |
| 560 @ 25 (MHz) | G, J, K | 23 @ 50 | 340 | 2.100 | 230 | |
| 600 @ 25 (MHz) | G, J, K | 23 @ 50 | 260 | 1.600 | 450 | |
| 620 @ 25 (MHz) | G, J, K | 23 @ 50 | 220 | 2.200 | 210 | |
| 680 @ 25 (MHz) | G, J, K | 23 @ 50 | 188 | 2.300 | 190 | |
| 750 @ 25 (MHz) | G, J, K | 23 @ 50 | 200 | 2.300 | 180 | |
| 820 @ 25 (MHz) | G, J, K | 23 @ 50 | 200 | 2.350 | 180 | |
| 910 @ 25 (MHz) | G, J, K | 18 @ 50 | 120 | 1.900 | 170 | |
| 1000 @ 25 (MHz) | G, J, K | 20 @ 50 | 100 | 2.500 | 170 | |
| 1200 @ 25 (MHz) | G, J, K | 18 @ 25 | 100 | 2.500 | 170 | |
| 1500 @ 25 (MHz) | G, J, K | 16 @ 25 | 100 | 2.500 | 170 | |
| 1800 @ 25 (MHz) | G, J, K | 16 @ 7.9 | 80 | 2.500 | 170 | |
| 2200 @ 25 (MHz) | G, J, K | 16 @ 7.9 | 60 | 2.700 | 160 | |
| 2700 @ 25 (MHz) | G, J, K | 16 @ 7.9 | 50 | 2.950 | 150 | |
| 3300 @ 7.9 (MHz) | G, J, K | 15 @ 7.9 | 40 | 4.400 | 90 | |
| 4700 @ 7.9 (MHz) | G, J, K | 15 @ 7.9 | | | | |

NOTE: For Mechanical Configurations, see page 7.

ATC Part Number Code

0805
WL
100
K
T

EIA Case Size: 0402, 0603, 0805, 1008, 1206

Wire Wound Inductor

Inductance value in nH.
1st and 2nd digits are significant digits. 3rd digit is multiplier. R is decimal point.

The above part number refers to an ATC 0805 WL wire wound chip inductor, 10 nH, J (±10%) tolerance, in tape and reel packaging. Tighter tolerances are available. Consult factory.

Terminations for all WL Series Inductor Case Sizes are **Lead-Free, RoHS Compliant, Tin Plated over Nickel Barrier.**

Packaging: T - Tape & Reel

Tolerance: See table below.

| Inductance Tolerances | | | |
|-----------------------|------|------|-------|
| Code | G | J | K |
| Tol. | ± 2% | ± 5% | ± 10% |

A M E R I C A N T E C H N I C A L C E R A M I C S

ATC North America
sales@atceramics.com

ATC Europe
sales@atceramics.com

ATC Asia
sales@atceramics-asia.com

ATC 1008 WL SERIES WIRE WOUND CHIP INDUCTORS

| Inductance (nH) | Tolerance Code | Q (MHz) | SRF (MHz) | RDC (Ohms) | IDC (mA) |
|--------------------|----------------|-----------|-----------|------------|----------|
| | | min. | min. | max. | max. |
| 4.7 @ 50 (MHz) | J, K | 50 @ 1500 | 4000 | 0.15 | 1000 |
| 5.6 @ 50 (MHz) | J, K | 50 @ 1500 | 4000 | 0.15 | 1000 |
| 10 @ 50 (MHz) | G, J, K | 50 @ 500 | 4100 | 0.08 | 1000 |
| 12 @ 50 (MHz) | G, J, K | 50 @ 500 | 3300 | 0.09 | 1000 |
| 15 @ 50 (MHz) | G, J, K | 50 @ 500 | 2500 | 0.11 | 1000 |
| 18 @ 50 (MHz) | G, J, K | 50 @ 350 | 2400 | 0.12 | 1000 |
| 22 @ 50 (MHz) | G, J, K | 55 @ 350 | 2400 | 0.12 | 1000 |
| 24 @ 50 (MHz) | G, J, K | 55 @ 350 | 1900 | 0.12 | 1000 |
| 27 @ 50 (MHz) | G, J, K | 55 @ 350 | 1600 | 0.13 | 1000 |
| 33 @ 50 (MHz) | G, J, K | 60 @ 350 | 1600 | 0.14 | 1000 |
| 36 @ 50 (MHz) | G, J, K | 60 @ 350 | 1600 | 0.15 | 1000 |
| 39 @ 50 (MHz) | G, J, K | 60 @ 350 | 1500 | 0.15 | 1000 |
| 47 @ 50 (MHz) | G, J, K | 65 @ 350 | 1500 | 0.16 | 1000 |
| 56 @ 50 (MHz) | G, J, K | 65 @ 350 | 1300 | 0.18 | 1000 |
| 62 @ 50 (MHz) | G, J, K | 65 @ 350 | 1250 | 0.20 | 1000 |
| 68 @ 50 (MHz) | G, J, K | 65 @ 350 | 1300 | 0.20 | 1000 |
| 75 @ 50 (MHz) | G, J, K | 60 @ 350 | 1100 | 0.21 | 1000 |
| 82 @ 50 (MHz) | G, J, K | 60 @ 350 | 1000 | 0.22 | 1000 |
| 91 @ 50 (MHz) | G, J, K | 50 @ 350 | 1000 | 0.45 | 1000 |
| 100 @ 25 (MHz) | G, J, K | 60 @ 350 | 1000 | 0.56 | 650 |
| 120 @ 25 (MHz) | G, J, K | 60 @ 350 | 950 | 0.63 | 650 |
| 150 @ 25 (MHz) | G, J, K | 45 @ 100 | 850 | 0.70 | 800 |
| 180 @ 25 (MHz) | G, J, K | 45 @ 100 | 750 | 0.77 | 620 |
| 220 @ 25 (MHz) | G, J, K | 45 @ 100 | 700 | 0.84 | 500 |
| 240 @ 25 (MHz) | G, J, K | 45 @ 100 | 650 | 0.88 | 500 |
| 270 @ 25 (MHz) | G, J, K | 45 @ 100 | 600 | 0.91 | 690 |
| 300 @ 25 (MHz) | G, J, K | 45 @ 100 | 585 | 1.00 | 450 |
| 330 @ 25 (MHz) | G, J, K | 45 @ 100 | 570 | 1.05 | 450 |
| 360 @ 25 (MHz) | G, J, K | 45 @ 100 | 530 | 1.10 | 470 |
| 390 @ 25 (MHz) | G, J, K | 45 @ 100 | 500 | 1.12 | 630 |
| 430 @ 25 (MHz) | G, J, K | 45 @ 100 | 480 | 1.15 | 470 |
| 470 @ 25 (MHz) | G, J, K | 45 @ 100 | 450 | 1.19 | 470 |
| 490 @ 25 (MHz) | G, J, K | 45 @ 100 | 420 | 1.25 | 470 |
| 560 @ 25 (MHz) | G, J, K | 45 @ 100 | 415 | 1.33 | 580 |
| 620 @ 25 (MHz) | G, J, K | 45 @ 100 | 375 | 1.40 | 300 |
| 680 @ 25 (MHz) | G, J, K | 45 @ 100 | 375 | 1.47 | 540 |
| 750 @ 25 (MHz) | G, J, K | 45 @ 100 | 360 | 1.54 | 360 |
| 820 @ 25 (MHz) | G, J, K | 45 @ 100 | 350 | 1.61 | 400 |
| 910 @ 25 (MHz) | G, J, K | 35 @ 50 | 320 | 1.68 | 380 |
| 1000 @ 25 (MHz) | G, J, K | 35 @ 50 | 290 | 1.75 | 370 |
| 1200 @ 7.9 (MHz) | G, J, K | 35 @ 50 | 250 | 2.00 | 310 |
| 1500 @ 7.9 (MHz) | G, J, K | 28 @ 50 | 200 | 2.30 | 330 |
| 1800 @ 7.9 (MHz) | G, J, K | 28 @ 50 | 160 | 2.60 | 300 |
| 2200 @ 7.9 (MHz) | G, J, K | 28 @ 50 | 160 | 2.80 | 280 |
| 2700 @ 7.9 (MHz) | G, J, K | 22 @ 25 | 140 | 3.20 | 290 |
| 3300 @ 7.9 (MHz) | G, J, K | 22 @ 25 | 110 | 3.40 | 290 |
| 3900 @ 7.9 (MHz) | G, J, K | 20 @ 25 | 100 | 3.60 | 260 |
| 4700 @ 7.9 (MHz) | G, J, K | 18 @ 25 | 90 | 4.00 | 260 |
| 5600 @ 7.9 (MHz) | G, J, K | 16 @ 7.96 | 20 | 4.00 | 240 |
| 6800 @ 7.9 (MHz) | G, J, K | 15 @ 7.96 | 40 | 4.90 | 200 |
| 8200 @ 7.9 (MHz) | G, J, K | 15 @ 7.96 | 25 | 6.00 | 170 |
| 10000 @ 2.52 (MHz) | G, J, K | 16 @ 7.96 | 20 | 9.00 | 150 |
| 12000 @ 2.52 (MHz) | G, J, K | 15 @ 7.96 | 18 | 10.5 | 130 |
| 15000 @ 2.52 (MHz) | G, J, K | 15 @ 7.96 | 15 | 11.5 | 120 |

NOTE: For Mechanical Configurations, see page 7.

ATC Part Number Code

1008 WL 100 K T

EIA Case Size: 0402, 0603, 0805, 1008, 1206

Wire Wound Inductor

Inductance value in nH.

1st and 2nd digits are significant digits. 3rd digit is multiplier. R is decimal point.

The above part number refers to an ATC 1008 WL wire wound chip inductor, 10 nH, J ($\pm 10\%$) tolerance, in tape and reel packaging. Tighter tolerances are available. Consult factory.

Terminations for all WL Series Inductor Case Sizes are **Lead-Free, RoHS Compliant**, Tin Plated over Nickel Barrier.

Packaging: T - Tape & Reel

Tolerance: See table below.

| Inductance Tolerances | | | |
|-----------------------|-----------|-----------|------------|
| Code | G | J | K |
| Tol. | $\pm 2\%$ | $\pm 5\%$ | $\pm 10\%$ |

A M E R I C A N T E C H N I C A L C E R A M I C S

ATC North America
sales@atceramics.com

ATC Europe
sales@atceramics.com

ATC Asia
sales@atceramics-asia.com

www.atceramics.com

ATC 1206 WL SERIES WIRE WOUND CHIP INDUCTORS

| Inductance (nH) | Tolerance Code | Q (MHz) | SRF (MHz) | RDC (Ohms) | IDC (mA) |
|-----------------|----------------|----------|-----------|------------|----------|
| | | min. | min. | max. | max. |
| 6.8 @ 100 (MHz) | J, K | 30 @ 300 | 5500 | .070 | 1000 |
| 10 @ 100 (MHz) | J, K | 40 @ 300 | 4000 | .080 | 1000 |
| 12 @ 100 (MHz) | J, K | 40 @ 300 | 3200 | .080 | 1000 |
| 15 @ 100 (MHz) | J, K | 40 @ 300 | 3200 | .100 | 1000 |
| 18 @ 100 (MHz) | J, K | 50 @ 300 | 2800 | .100 | 1000 |
| 22 @ 100 (MHz) | J, K | 50 @ 300 | 2200 | .100 | 1000 |
| 24 @ 100 (MHz) | J, K | 50 @ 300 | 2000 | .100 | 1000 |
| 27 @ 100 (MHz) | G, J, K | 50 @ 300 | 1800 | .110 | 1000 |
| 33 @ 100 (MHz) | G, J, K | 55 @ 300 | 1800 | .110 | 1000 |
| 39 @ 100 (MHz) | G, J, K | 55 @ 300 | 1800 | .120 | 1000 |
| 47 @ 100 (MHz) | G, J, K | 55 @ 300 | 1500 | .130 | 1000 |
| 56 @ 100 (MHz) | G, J, K | 55 @ 300 | 1450 | .140 | 1000 |
| 68 @ 100 (MHz) | G, J, K | 55 @ 300 | 1200 | .260 | 950 |
| 82 @ 100 (MHz) | G, J, K | 55 @ 300 | 1200 | .210 | 920 |
| 91 @ 100 (MHz) | G, J, K | 55 @ 300 | 1100 | .240 | 900 |
| 100 @ 100 (MHz) | G, J, K | 55 @ 300 | 1100 | .260 | 850 |
| 120 @ 100 (MHz) | G, J, K | 55 @ 300 | 750 | .260 | 800 |
| 150 @ 100 (MHz) | G, J, K | 60 @ 300 | 950 | .310 | 750 |
| 180 @ 50 (MHz) | G, J, K | 55 @ 300 | 900 | .430 | 700 |
| 220 @ 50 (MHz) | G, J, K | 55 @ 300 | 760 | .500 | 670 |
| 270 @ 50 (MHz) | G, J, K | 40 @ 300 | 740 | .560 | 630 |
| 300 @ 50 (MHz) | G, J, K | 50 @ 150 | 680 | .600 | 600 |
| 330 @ 50 (MHz) | G, J, K | 45 @ 150 | 650 | .620 | 590 |
| 360 @ 50 (MHz) | G, J, K | 45 @ 150 | 600 | .650 | 550 |
| 390 @ 50 (MHz) | G, J, K | 45 @ 150 | 600 | .750 | 530 |
| 470 @ 50 (MHz) | G, J, K | 45 @ 150 | 550 | 1.30 | 490 |
| 560 @ 35 (MHz) | G, J, K | 45 @ 150 | 470 | 1.34 | 460 |
| 620 @ 35 (MHz) | G, J, K | 45 @ 150 | 470 | 1.58 | 460 |
| 680 @ 35 (MHz) | G, J, K | 45 @ 150 | 450 | 1.58 | 430 |
| 750 @ 35 (MHz) | G, J, K | 45 @ 150 | 440 | 2.25 | 320 |
| 820 @ 35 (MHz) | G, J, K | 45 @ 150 | 420 | 1.82 | 400 |
| 910 @ 35 (MHz) | G, J, K | 45 @ 150 | 410 | 2.95 | 310 |
| 1000 @ 35 (MHz) | G, J, K | 45 @ 150 | 400 | 2.80 | 320 |
| 1200 @ 35 (MHz) | G, J, K | 45 @ 150 | 380 | 3.20 | 300 |

NOTE: For Mechanical Configurations, see page 7.

ATC Part Number Code

1206 WL 100 K T

EIA Case Size: 0402, 0603, 0805, 1008, 1206

Wire Wound Inductor

Inductance value in nH.
1st and 2nd digits are significant digits. 3rd digit is multiplier. R is decimal point.

The above part number refers to an ATC 1206 WL wire wound chip inductor, 10 nH, J (±10%) tolerance, in tape and reel packaging. Tighter tolerances are available. Consult factory.

Terminations for all WL Series Inductor Case Sizes are **Lead-Free, RoHS Compliant**, Tin Plated over Nickel Barrier.

Packaging: T - Tape & Reel
Tolerance: See table below.

| Inductance Tolerances | | | |
|-----------------------|------|------|-------|
| Code | G | J | K |
| Tol. | ± 2% | ± 5% | ± 10% |

1206 Series available by special order non stock item, consult factory for availability.

A M E R I C A N T E C H N I C A L C E R A M I C S

ATC North America
sales@atceramics.com

ATC Europe
sales@atceramics.com

ATC Asia
sales@atceramics-asia.com

ATC WL SERIES WIRE WOUND CHIP INDUCTORS

Mechanical Configurations

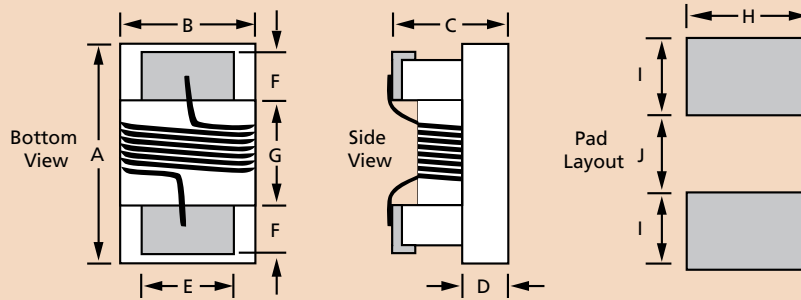

| WL Case Size/ Series | A max. | B max. | C max. | D ref. | E | F | G | H | I | J |
|-------------------------|--------------|-------------|-------------|-------------|-------------|-------------|-------------|-------------|-------------|-------------|
| 0402 | .050 (1.27) | .030 (0.76) | .024 (0.61) | .006 (0.15) | .020 (0.51) | .009 (0.23) | .022 (0.56) | .026 (0.66) | .019 (0.50) | .018 (0.46) |
| 0603 | .071 (1.80) | .044 (1.12) | .040 (1.02) | .015 (0.38) | .030 (0.76) | .013 (0.33) | .034 (0.86) | .040 (1.02) | .025 (0.64) | .025 (0.64) |
| 0805 | 0.09 (2.29) | .068 (1.73) | 0.06 (1.52) | 0.02 (0.51) | 0.05 (1.27) | 0.02 (0.51) | 0.04 (1.02) | 0.07 (1.78) | 0.04 (1.02) | 0.03 (0.76) |
| 1008 | 0.115 (2.92) | 0.11 (2.79) | 0.08 (2.03) | 0.02 (0.51) | 0.08 (2.03) | 0.02 (0.51) | 0.06 (1.52) | 0.10 (2.54) | 0.04 (1.02) | 0.05 (1.27) |
| 1206 | 0.14 (3.56) | .085 (2.16) | 0.06 (1.52) | 0.02 (0.51) | 0.06 (1.52) | 0.02 (0.51) | 0.08 (2.03) | 0.08 (2.03) | 0.04 (1.02) | 0.07 (1.78) |

Inches (mm)

Terminations for all WL Series Inductor Case Sizes are **Lead-Free, RoHS Compliant**, Tin Plated over Nickel Barrier.

Tape and Reel Specifications

ATC WL Series Inductor Products are supplied on tape and reel in standard quantities of 2000 and 4000 parts per reel (see table below), making them ideal for automated pick and place manufacturing applications.

Packaging

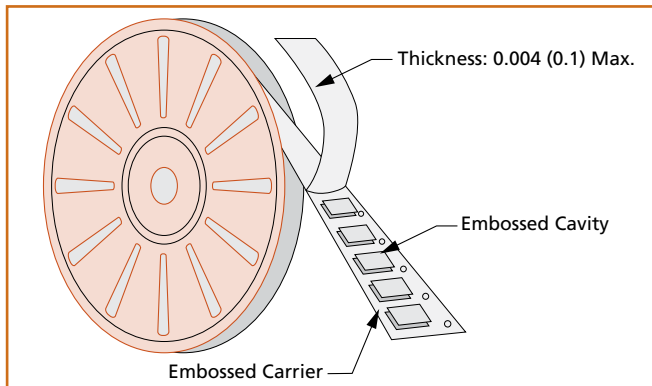

Tape Dimensions

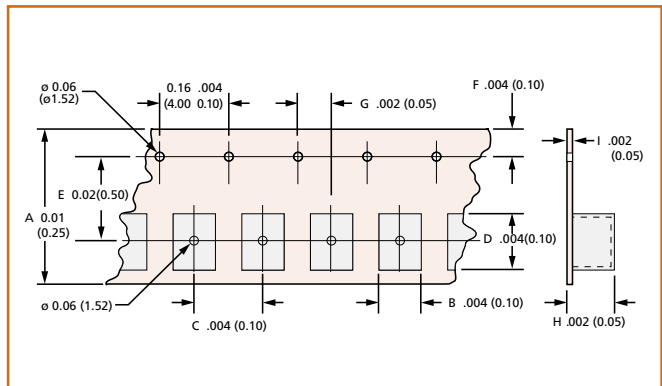

| WL Case Size / Series | A Dim. | B Dim. | C Dim. | D Dim. | E Dim. | F Dim. | G Dim. | H Dim. | I Dim. | Pcs. / per reel |
|-----------------------|-------------|-------------|-------------|-------------|-------------|-------------|-------------|-------------|-------------|-----------------|
| 0402 | 0.32 (8.00) | .044 (1.10) | .080 (2.00) | .070 (1.75) | .140 (3.50) | .070 (1.75) | .080 (2.00) | .024 (0.60) | .010 (0.25) | 4000 |
| 0603 | 0.32 (8.00) | .044 (1.10) | 0.16 (4.00) | .070 (1.75) | .140 (3.50) | .070 (1.75) | .080 (2.00) | .042 (1.05) | .010 (0.25) | 4000 |
| 0805 | 0.32 (8.00) | .075 (1.88) | 0.16 (4.00) | .095 (2.38) | .140 (3.50) | .070 (1.75) | .080 (2.00) | .054 (1.35) | .008 (0.20) | 2000 |
| 1008 | 0.32 (8.00) | .109 (2.73) | 0.16 (4.00) | .115 (2.88) | .140 (3.50) | .070 (1.75) | .080 (2.00) | .090 (2.25) | .008 (0.20) | 2000 |
| 1206 | 0.32 (8.00) | .109 (2.73) | 0.16 (4.00) | .115 (2.88) | .140 (3.50) | .070 (1.75) | .080 (2.00) | 0.10 (2.50) | .008 (0.20) | 2000 |

A M E R I C A N T E C H N I C A L C E R A M I C S

ATC North America
sales@atceramics.com

ATC Europe
sales@atceramics.com

ATC Asia
sales@atceramics-asia.com

www.atceramics.com

ATC WL SERIES WIRE WOUND CHIP INDUCTORS

Inductor Quality Assurance:

ATC ensures that all of its contracted component manufacturing facilities are ISO 9000 Registered, and that an outgoing product quality level of better than 100 PPM is maintained. ATC's WL Series products have successfully passed the most rigorous environmental, mechanical and electrical validations. All manufacturing lots receive a tollgate sample inspection of the primary parameter values used to specify an inductor. The test equipment and fixtures listed below in the RF Measurement Table are used to verify RF performance parameters for ATC's WL Series Inductor Products.

Quality and Reliability Testing - Environmental

| Item | Examination | Test Method | Performance Specs. |
|------|--------------------------|---|--|
| 1 | High Temperature Storage | Inductors are subjected to +125°C for 48 hours, then tested after 1 hour at room temperature. | <ul style="list-style-type: none"> Inductors shall not have a shorted or open winding Change in inductance shall not change more than ±5%. Change in Q shall not change more than ±10%. |
| 2 | Low Temperature Storage | Inductors are subjected to -40°C for 48 hours, then tested after 1 hour at room temperature | |
| 3 | Thermal Shock | Inductors are subjected to 10 cycles of -40°C for 30 min. and +125°C for 30 min., then tested after 1 hour at room temperature. | |
| 4 | Moisture Resistance | Inductors are subjected to 10 25-hour cycles from 25°C to 65°C at 80 to 90% RH, and are exposed to -10°C for 3 hours during one of the cycles. Samples are then tested after 2 hours at room temperature. | |
| 5 | Life Test | Inductors are subjected to 110°C for 1,000 hours at rated current. Samples are then tested after 1 hour at room temperature. | |

Quality and Reliability Testing - Mechanical

| Item | Examination | Test Method | Performance Specifications |
|------|-------------------|---|--|
| 1 | Solderability Dip | Dip terminals into molten Sn63 at 235°C for 5 sec. | Terminals shall exhibit a continuous solder coating free of defects for a minimum of 95% of surface. |
| 2 | Adhesion | Reflow solder to circuit lands. A force gauge is applied to side of component | 1 lb. for 0402, 2 lbs. for 0603, 4 lbs. for all larger parts |
| 3 | Vibration | 10 to 2000 Hz, 5 Gs for 20 minutes, 12 cycles each, 3 orientations | 1. No mechanical damage 2. Change in L less than ±5% 3. Change in Q less than ±10% |
| 4 | Mechanical Shock | MIL-STD-202, method 213, condition A. Test mounted parts 2 axes 6 times (50 G's, 11 ms, half-sine). | 1. No mechanical damage 2. Change in L less than ±5% 3. Change in Q less than ±10% |

RF Test Measurements

| Measured Parameter | Test Equipment | Fixture(s) |
|-------------------------------|----------------------------------|--|
| Inductance (L) | HP 4291B Impedance Analyzer | Bottom Electrode SMD Test Fixture, Model 16197A |
| Quality Factor (Q) | | |
| Self Resonant Frequency (SRF) | HP 8722D Vector Network Analyzer | Anritsu Universal test fixture Model 3680K with substrate DUT adapters |
| DC Resistance (DCR) | Micro-ohm meter | Four Wire Kelvin Probes |

Inductor Design Kits

ATC's WL Series Inductor Design Kits contain a selection of standard inductance values for circuit prototyping.

| Kit # | Item # | Description | Inductor Value range (nH) | Inductor Values (nH) | Tol. | Price |
|--------|--------|---|---------------------------|--|------|----------|
| Kit 51 | DK0051 | 0402 WL Chip Inductors 41 different values, 15 pieces per value | 1.0nH to 120nH | 1.0, 1.8, 2.0, 2.2, 2.7, 3.3, 3.6, 3.9, 4.3, 4.7, 5.1, 5.6, 6.2, 6.8, 7.5, 8.2, 8.7, 9, 10, 11, 12, 13, 15, 18, 20, 22, 27, 30, 33, 36, 39, 40, 43, 47, 51, 56, 68, 72, 82, 100, 120 | 5% | \$140.00 |
| Kit 52 | DK0052 | 0603 WL Chip Inductors 50 different values, 15 pieces per value | 1.6nH to 390nH | 1.6, 1.8, 2.2, 2.4, 3.3, 3.9, 4.3, 5.1, 5.6, 6.3, 6.8, 7.5, 8.2, 8.7, 9.5, 10, 11, 12, 15, 17, 20, 22, 24, 27, 30, 33, 36, 39, 43, 47, 51, 56, 62, 68, 75, 82, 91, 100, 110, 120, 140, 160, 180, 220, 240, 260, 280, 300, 330, 390 | 5% | \$140.00 |
| Kit 53 | DK0053 | 0805 WL Chip Inductors 50 different values, 15 pieces per value | 2.7nH to 2700nH | 2.7, 3.0, 3.3, 5.6, 6.8, 7.5, 8.2, 8.7, 10, 12, 15, 18, 22, 24, 27, 30, 36, 39, 47, 56, 68, 72, 82, 91, 100, 110, 120, 150, 180, 200, 220, 240, 270, 300, 330, 390, 470, 560, 600, 620, 680, 750, 820, 910, 1000, 1200, 1500, 1800, 2200, 2700 | 5% | \$140.00 |
| Kit 54 | DK0054 | 1008 WL Chip Inductors 44 different values, 15 pieces per value | 4.7nH to 15,000nH | 4.7, 10, 15, 18, 24, 27, 33, 39, 47, 56, 68, 75, 82, 91, 100, 120, 150, 180, 220, 240, 270, 300, 330, 360, 390, 430, 470, 560, 620, 680, 750, 820, 910, 1000, 1200, 1500, 1800, 2200, 2700, 3300, 3900, 4700, 5600, 15,000 | 5% | \$140.00 |

A M E R I C A N T E C H N I C A L C E R A M I C S

ATC North America
sales@atceramics.com

ATC Europe
sales@atceramics.com

ATC Asia
sales@atceramics-asia.com

CONTACT INFORMATION

ATC NORTH AMERICA

AMERICAN TECHNICAL CERAMICS

One Norden Lane, Huntington Station, NY 11746-2142
Phone: +1-631-622-4700 • Fax: +1-631-622-4748
email: sales@atceramics.com • website: www.atceramics.com

ATC EUROPE

American Technical Ceramics' Sales and Customer Service Center, serving Europe, Africa and the Middle East, is located in the Czech Republic.

AMERICAN TECHNICAL CERAMICS CUSTOMER SERVICE CENTER

Za Olsavkou 303
686 01 Uherske Hradiste
Czech Republic
Phone: +420 575757520 • Fax: +420 575757109
e-mail: saleseur@atceramics.com • website: www.atceramics.com

AMERICAN TECHNICAL CERAMICS REGIONAL SALES OFFICE, WESTERN EUROPE

6 Archipelago Park
Lyon Way, Frimley
GU167ER
Surrey, UK
Mobile: +420 575757520
e-mail: sgudge@atceramics.com • website: www.atceramics.com

AMERICAN TECHNICAL CERAMICS REGIONAL SALES OFFICE, EASTERN EUROPE

c/o AVX GmbH
Lilienthalstr. 17/17a
85399 Hallbergmoos
Germany
Phone: +49 811 959 4931 • Mobile: +49 172 8404 775
e-mail: arinortner@atceramics.com • website: www.atceramics.com

ATC ASIA / INDIA SALES AND TECHNICAL SUPPORT OFFICE

AMERICAN TECHNICAL CERAMICS (CHINA) LIMITED

Unit D & E, 11/F JunYun Century Building,
No. 6033 Chegongmiao, Shennan Road, Futian Dist. Shenzhen,
Guangdong Province, 518031 P. R. China
Phone: +86 755 2396 8759 • Fax: +86 755 2396 8442
e-mail: sales@atceramics-asia.com • website: www.atceramics-asia.com

Sales of ATC products are subject to the terms and conditions contained in American Technical Ceramics Corp. Terms and Conditions of Sale (ATC document #001-992 Rev. B 12/05). Copies of these terms and conditions will be provided upon request. They may also be viewed on ATC's website at www.atceramics.com/productfinder/default.asp. Click on the link for Terms and Conditions of Sale.

ATC has made every effort to have this information as accurate as possible. However, no responsibility is assumed by ATC for its use, nor for any infringements of rights of third parties which may result from its use. ATC reserves the right to revise the content or modify its product without prior notice.

© 2001 American Technical Ceramics Corp. All Rights Reserved.

ATC # 001-960 Rev. V; 12/17

A M E R I C A N T E C H N I C A L C E R A M I C S

ATC North America
sales@atceramics.com

ATC Europe
saleseur@atceramics.com

ATC Asia
sales@atceramics-asia.com

www.atceramics.com



AMERICAN

ATC North America
sales@atceramics.com

TECHNICAL

ATC Europe
saleseur@atceramics.com

CERAMICS

ATC Asia
sales@atceramics-asia.com

THE ENGINEERS' CHOICE™

www.atceramics.com



ISO 9001 REGISTERED
COMPANY