

## BROADCAST MECHANICAL TUNING AM/FM/SW RADIO RECEIVER

### Features

- Worldwide FM band support (64–109 MHz)
- Worldwide AM band support (504–1750 kHz)
- SW band support (5.6–22 MHz)
- Excellent real-world performance
- Enhanced short wave tuning experience
- EN55020-compliant
- No manual alignment necessary
- Flexible band selections
- Automatic frequency control (AFC)
- Integrated LDO regulator
- 2.0 to 3.6 V supply voltage
- Wide range of ferrite loop sticks and air loop antennas supported
- 24-pin SSOP
- RoHS-compliant
- Supports station and stereo LED indicators
- Direct volume control
- Bass and treble tone control

### Applications

- Table and portable radios
- Stereos
- Mini/micro systems
- CD/DVD players
- Boom boxes
- Modules
- Clock radios
- Mini HiFi
- Entertainment systems
- Multi Band Radio

### Description

The Si4835-B31 is the 2nd generation mechanical-tuned digital CMOS AM/FM/SW radio receiver IC that integrates the complete receiver function from antenna input to audio output. The Si4835-B31 extends Silicon Laboratories' multi-band tuner family and further increases the ease and attractiveness of adding SW radio reception to audio devices through small size and board area, minimum component count, and superior, proven performance. The Si4835-B31 is pin-to-pin compatible with the existing Si4831/5-B30 tuner. The Si4835-B31 requires a simple application circuit and removes any requirements for manually tuning components during the manufacturing process. The Si4835-B31 is a very simple product to design, manufacture, and support across multiple product lines. The receiver has very low power consumption, runs off two AAA batteries, and delivers the performance benefits of digital tuning to the analog radio market.

### Functional Block Diagram

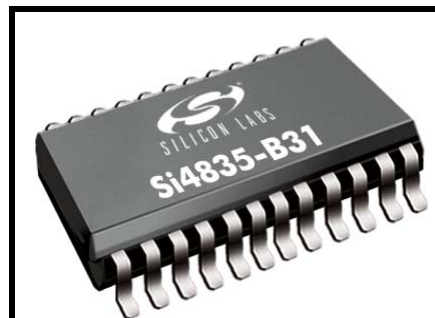
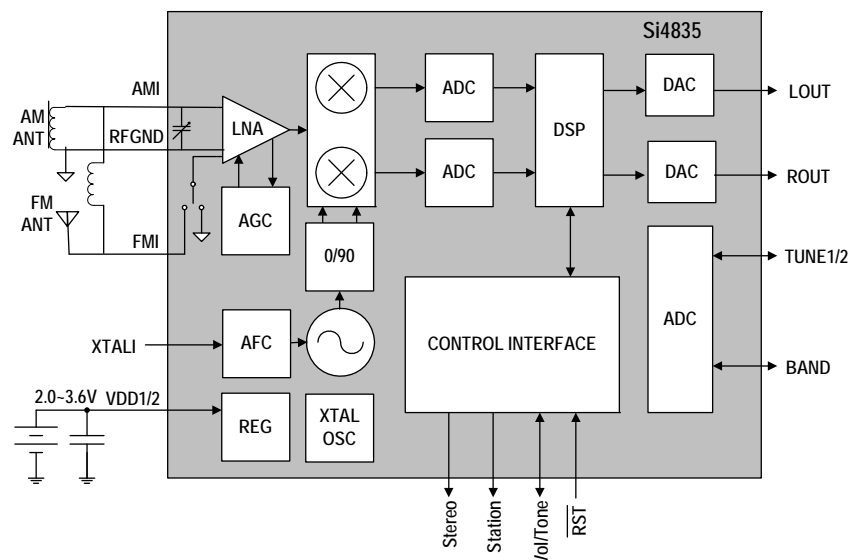

**Ordering Information:**  
See page 14.

### Pin Assignments

#### Si4835-B31 (SSOP)

STEREO	1	24	LOUT
STATION	2	23	ROUT
TUNE1	3	22	DBYP
TUNE2	4	21	VDD2
BAND	5	20	VDD1
NC	6	19	XTALI
NC	7	18	XTALO
FMI	8	17	VOL-/BASS
RFGND	9	16	VOL+/TREBLE
NC	10	15	RST
NC	11	14	GND
AMI	12	13	GND

This product, its features, and/or its architecture is covered by one or more of the following patents, as well as other patents, pending and issued, both foreign and domestic: 7,127,217; 7,272,373; 7,272,375; 7,321,324; 7,355,476; 7,426,376; 7,471,940; 7,339,503; 7,339,504.



---

**TABLE OF CONTENTS**

---

<b><u>Section</u></b>	<b><u>Page</u></b>
<b>1. Electrical Specifications</b> .....	<b>4</b>
<b>2. Typical Application Schematic</b> .....	<b>9</b>
<b>3. Bill of Materials</b> .....	<b>10</b>
<b>4. Functional Description</b> .....	<b>11</b>
4.1. Overview .....	11
4.2. FM Receiver .....	11
4.3. AM Receiver .....	12
4.4. SW Receiver .....	12
4.5. Frequency Tuning .....	12
4.6. Band Select .....	12
4.7. Bass and Treble .....	12
4.8. Volume Control .....	12
<b>5. Pin Descriptions: Si4835-B31</b> .....	<b>13</b>
<b>6. Ordering Guide</b> .....	<b>14</b>
<b>7. Package Markings (Top Marks)</b> .....	<b>15</b>
7.1. Si4835-B31 Top Mark .....	15
7.2. Top Mark Explanation .....	15
<b>8. Package Outline: Si4835-B31</b> .....	<b>16</b>
<b>9. PCB Land Pattern: Si4835-B31</b> .....	<b>17</b>
<b>10. Additional Reference Resources</b> .....	<b>18</b>
<b>Contact Information</b> .....	<b>20</b>

# Si4835-B31

---

## 1. Electrical Specifications

**Table 1. Recommended Operating Conditions<sup>1,2</sup>**

Parameter	Symbol	Test Condition	Min	Typ	Max	Unit
Supply Voltage <sup>3</sup>	$V_{DD}$		2	—	3.6	V
Power Supply Powerup Rise Time	$V_{DDRISE}$		10	—	—	$\mu$ s

**Note:**

1. Typical values in the data sheet apply at  $V_{DD} = 3.3$  V and 25 °C unless otherwise stated.
2. All minimum and maximum specifications in the data sheet apply across the recommended operating conditions for minimum  $V_{DD} = 2.7$  V.
3. Operation at minimum  $V_{DD}$  is guaranteed by characterization when  $V_{DD}$  voltage is ramped down to 2.0 V. Part initialization may become unresponsive below 2.3 V.

**Table 2. DC Characteristics** $(V_{DD} = 2.7 \text{ to } 3.6 \text{ V}, T_A = -15 \text{ to } 85 \text{ }^\circ\text{C})$ 

Parameter	Symbol	Test Condition	Min	Typ	Max	Unit
<b>FM Mode</b>						
Supply Current <sup>1</sup>	$I_{FM}$		—	21.0	—	mA
Supply Current <sup>2</sup>	$I_{FM}$	Low SNR level	—	21.5	—	mA
<b>AM/SW Mode</b>						
Supply Current <sup>1</sup>	$I_{AM}$		—	17.0	—	mA
<b>Supplies and Interface</b>						
$V_{DD}$ Powerdown Current	$I_{DDPD}$		—	10	—	$\mu\text{A}$
<b>Notes:</b>						
1. Specifications are guaranteed by characterization.						
2. LNA is automatically switched to higher current mode for optimum sensitivity in weak signal conditions.						

**Table 3. Reset Timing Characteristics** $(V_{DD} = 2.7 \text{ to } 3.6 \text{ V}, T_A = -15 \text{ to } 85 \text{ }^\circ\text{C})$ 

Parameter	Symbol	Min	Typ	Max	Unit
$\overline{\text{RST}}$ Pulse Width and TUNE1, TUNE2 Setup to $\overline{\text{RST}}\uparrow$	$t_{SRST}$	100	—	—	$\mu\text{s}$

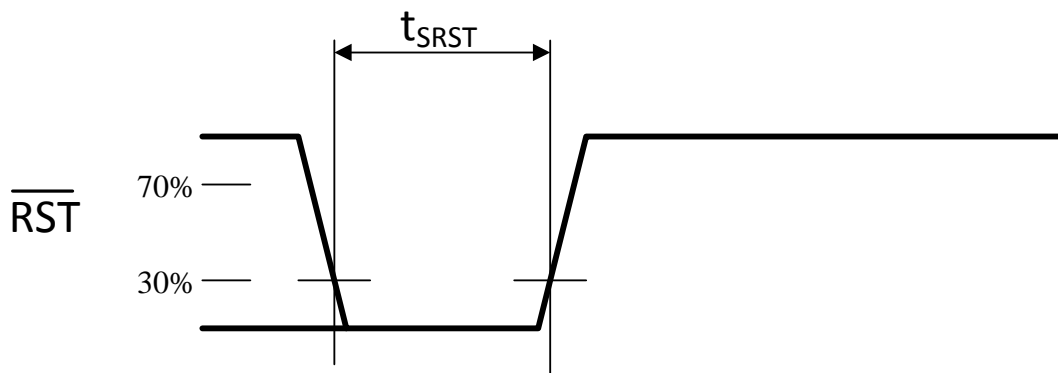
**Figure 1. Reset Timing**

# Si4835-B31

**Table 4. FM Receiver Characteristics<sup>1,2</sup>**

( $V_{DD}$  = 2.7 to 3.6 V,  $T_A$  = -15 to 85 °C)

Parameter	Symbol	Test Condition	Min	Typ	Max	Unit
Input Frequency	$f_{RF}$		64	—	109	MHz
Sensitivity with Headphone Network <sup>3</sup>		(S+N)/N = 26 dB	—	2.2	—	$\mu$ V EMF
LNA Input Resistance <sup>4,5</sup>			—	4	—	k $\Omega$
LNA Input Capacitance <sup>4,5</sup>			—	5	—	pF
AM Suppression <sup>4,5,6,7</sup>		m = 0.3	—	50	—	dB
Input IP <sub>3</sub> <sup>4,8</sup>			—	105	—	dB $\mu$ V EMF
Adjacent Channel Selectivity <sup>4</sup>		$\pm$ 200 kHz	—	50	—	dB
Alternate Channel Selectivity <sup>4</sup>		$\pm$ 400 kHz	—	65	—	dB
Audio Output Voltage <sup>5,6,7,12</sup>			—	80	—	mV <sub>RMS</sub>
Audio Mono S/N <sup>5,6,7,9,10</sup>			—	55	—	dB
Audio Stereo S/N <sup>3,4,5,7,9,10,</sup>			—	55	—	dB
Audio Frequency Response Low <sup>4</sup>		-3 dB	—	—	30	Hz
Audio Frequency Response High <sup>4</sup>		-3 dB	15	—	—	kHz
Audio Stereo Separation <sup>5,11</sup>			—	40	—	dB
Audio THD <sup>6,5,11</sup>			—	0.1	0.5	%
Audio Output Load Resistance <sup>4,10</sup>	$R_L$	Single-ended	10	—	—	k $\Omega$
Audio Output Load Capacitance <sup>4,10</sup>	$C_L$	Single-ended	—	—	50	pF
Powerup/Band Switch Time <sup>4</sup>			—	—	110	ms

**Notes:**

1. Additional testing information is available in “AN569: Si4831/35/20/24-DEMO Board Test Procedure.” Volume = maximum for all tests. Tested at RF = 98.1 MHz.
2. To ensure proper operation and receiver performance, follow the guidelines in “AN555: Si483x-B/Si4820/24 Antenna, Schematic, Layout, and Design Guidelines.” Silicon Laboratories will evaluate schematics and layouts for qualified customers.
3. Frequency is 64~109 MHz.
4. Guaranteed by characterization.
5.  $V_{EMF}$  = 1 mV.
6.  $F_{MOD}$  = 1 kHz, MONO, and L = R unless noted otherwise.
7.  $\Delta f$  = 22.5 kHz.
8.  $|f_2 - f_1| > 2$  MHz,  $f_0 = 2 \times f_1 - f_2$ .
9.  $B_{AF}$  = 300 Hz to 15 kHz, A-weighted.
10. At  $L_{OUT}$  and  $R_{OUT}$  pins.
11.  $\Delta f$  = 75 kHz.
12. Tested in Digital Volume Mode.

**Table 5. AM/SW Receiver Characteristics<sup>1, 2</sup>**(V<sub>DD</sub> = 2.7 to 3.6 V, T<sub>A</sub> = -15 to 85 °C)

Parameter	Symbol	Test Condition	Min	Typ	Max	Unit
Input Frequency	f <sub>RF</sub>	Medium Wave (AM)	504	—	1750	kHz
		Short Wave (SW)	5.60	—	22.0	MHz
Sensitivity <sup>3,4,5</sup>		(S+N)/N = 26 dB	—	30	—	μV EMF
Large Signal Voltage Handling <sup>5</sup>		THD < 8%	—	300	—	mV <sub>RMS</sub>
Power Supply Rejection Ratio <sup>5</sup>		ΔV <sub>DD</sub> = 100 mV <sub>RMS</sub> , 100 Hz	—	40	—	dB
Audio Output Voltage <sup>3,6,8</sup>			—	60	—	mV <sub>RMS</sub>
Audio S/N <sup>3,4,6</sup>			—	55	—	dB
Audio THD <sup>3,6</sup>			—	0.1	0.5	%
Antenna Inductance <sup>5,7</sup>			180	—	450	μH
Powerup/Band Switch Time <sup>5</sup>		From powerdown	—	—	110	ms

**Notes:**

1. Additional testing information is available in “AN569: Si4831/35/20/24-DEMO Board Test Procedure.” Volume = maximum for all tests. Tested at RF = 520 kHz.
2. To ensure proper operation and receiver performance, follow the guidelines in “AN555: Si483x-B/Si4820/24 Antenna, Schematic, Layout, and Design Guidelines.” Silicon Laboratories will evaluate schematics and layouts for qualified customers.
3. F<sub>MOD</sub> = 1 kHz, 30% modulation, 2 kHz channel filter.
4. B<sub>AF</sub> = 300 Hz to 15 kHz, A-weighted.
5. Guaranteed by characterization.
6. V<sub>IN</sub> = 5 mV<sub>rms</sub>.
7. Stray capacitance on antenna and board must be < 10 pF to achieve full tuning range at higher inductance levels.
8. Tested in Digital Volume Mode.

**Table 6. Reference Clock and Crystal Characteristics**(V<sub>DD</sub> = 2.7 to 3.6 V, T<sub>A</sub> = -15 to 85 °C)

Parameter	Symbol	Test Condition	Min	Typ	Max	Unit
<b>Reference Clock</b>						
XTALI Supported Reference Clock Frequencies			—	32.768	—	kHz
Reference Clock Frequency Tolerance for XTALI			-100	—	100	ppm
<b>Crystal Oscillator</b>						
Crystal Oscillator Frequency			—	32.768	—	kHz
Crystal Frequency Tolerance			-100	—	100	ppm
Board Capacitance			—	—	3.5	pF

# Si4835-B31

**Table 7. Thermal Conditions**

( $V_{DD} = 2.7$  to  $3.6$  V,  $T_A = -15$  to  $85$  °C)

Parameter	Symbol	Min	Typ	Max	Unit
Thermal Resistance*	$\Theta_{JA}$	—	80	—	°C/W
Ambient Temperature	$T_A$	-15	25	85	°C
Junction Temperature	$T_J$	—	—	92	°C

**\*Note:** Thermal resistance assumes a multi-layer PCB with the exposed pad soldered to a topside PCB pad.

**Table 8. Absolute Maximum Ratings<sup>1,2</sup>**

Parameter	Symbol	Value	Unit
Supply Voltage	$V_{DD}$	-0.5 to 5.8	V
Input Current <sup>3</sup>	$I_{IN}$	10	mA
Operating Temperature	$T_{OP}$	-40 to 95	°C
Storage Temperature	$T_{STG}$	-55 to 150	°C
RF Input Level <sup>4</sup>		0.4	$V_{PK}$

**Notes:**

1. Permanent device damage may occur if the above Absolute Maximum Ratings are exceeded. Functional operation should be restricted to the conditions as specified in the operational sections of this data sheet. Exposure beyond recommended operating conditions for extended periods may affect device reliability.
2. The Si4835-B31 devices are high-performance RF integrated circuits with certain pins having an ESD rating of < 2 kV HBM. Handling and assembly of these devices should only be done at ESD-protected workstations.
3. For input pins RST, VOL+/TREBLE, VOL-/BASS, XTALO, XTALI, BAND, TUNE2, TUNE1, STATION, and STEREO.
4. At RF input pins, FMI and AMI.

## 2. Typical Application Schematic

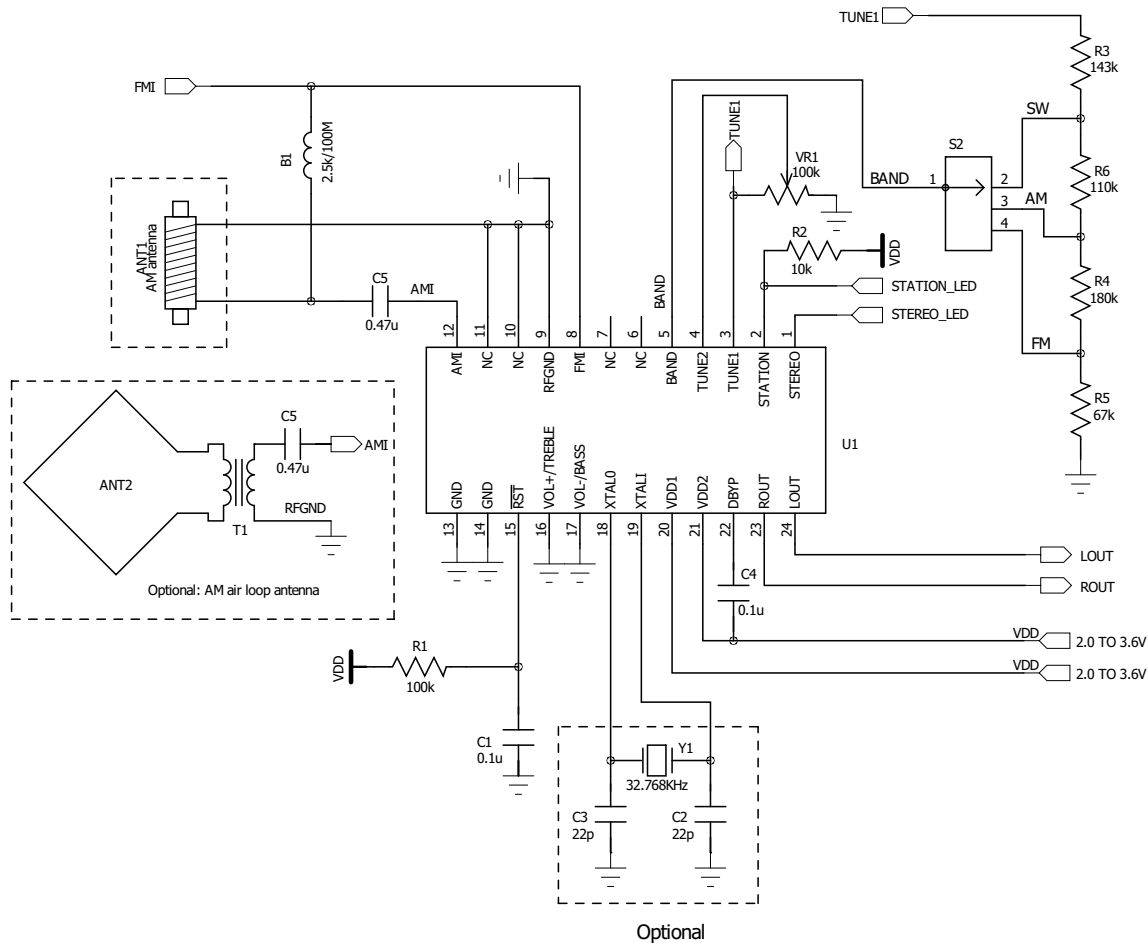

### Notes:

1. Place  $C_4$  close to  $V_{DD2}$  and DBYP pins.
2. All grounds connect directly to GND plane on PCB.
3. Leave pins 6 and 7 floating.
4. To ensure proper operation and receiver performance, follow the guidelines in "AN555: Si483x-B/Si4820/24 Antenna, Schematic, Layout, and Design Guidelines." Silicon Labs will evaluate the schematics and layouts for qualified customers.
5. Pin 8 connects to the FM antenna interface and pin 12 connects to the AM antenna interface.
6. Place Si483x as close as possible to the antenna jack and keep the FMI and AMI traces as short as possible.

# Si4835-B31

## 3. Bill of Materials

Table 9. Si4835-B31 Bill of Materials

Component(s)	Value/Description	Supplier
C1	Reset capacitor 0.1 uF, $\pm 20\%$ , Z5U/X7R	Murata
C4	Supply bypass capacitor, 0.1 uF, $\pm 20\%$ , Z5U/X7R	Murata
C5	Coupling capacitor, 0.47 $\mu$ F, $\pm 20\%$ , Z5U/X7R	Murata
B1	Ferrite bead 2.5k/100 MHz	Murata
VR1	Variable resistor (POT), 100k, $\pm 10\%$	Kennon
R1	Reset timing resistor, 100k, $\pm 5\%$	Venkel
R2	Resistor, 10k, $\pm 5\%$	Venkel
R3	Resistor, 143k, $\pm 1\%$	Venkel
R4	Resistor, 180k, $\pm 1\%$	Venkel
R5	Resistor, 67k, $\pm 1\%$	Venkel
R6	Resistor, 110k, $\pm 1\%$	Venkel
U1	Si4835-B31 Mechanical Tuning Radio Receiver	Silicon Laboratories
S2	Band switch	Any, depends on customer
ANT1	Ferrite stick, 180-450 $\mu$ H	Jiaxin
<b>Optional Components</b>		
C2, C3	Crystal load capacitors, 22 pF, $\pm 5\%$ , COG (Optional: for crystal oscillator option)	Venkel
Y1	32.768 kHz crystal (Optional: for crystal oscillator option)	Epson or equivalent
ANT2	Air loop antenna, 10-20 $\mu$ H	Various

## 4. Functional Description

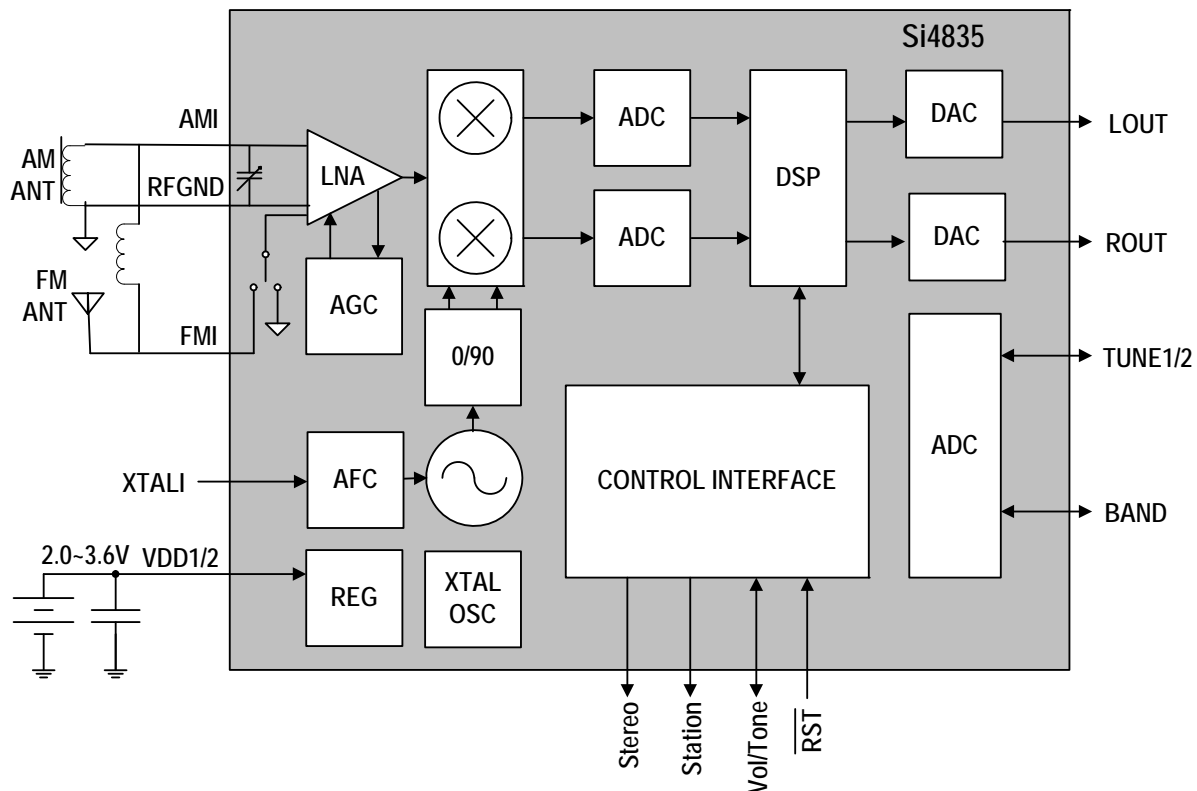

Figure 2. Si4835-B31 Functional Block Diagram

### 4.1. Overview

The Si4835-B31 is the industry's most advanced fully integrated, mechanical-tuned 100% CMOS AM/FM/SW radio receiver IC with short wave tuning experience enhancement and band switching noise improvement. The Si4835-B31 extends Silicon Laboratories' multi-band tuner family and further increases the ease and attractiveness of adding SW radio reception to audio devices through small size and board area, minimum component count, and superior, proven performance. Si4835-B31 is pin-to-pin compatible with the existing Si4831/35-B30 tuner. Offering unmatched integration and PCB space savings, the Si4835-B31 requires minimum external components and a small board area. The Si4835-B31 AM/FM/SW radio provides space savings and low power consumption while delivering the high performance and design simplicity desired for all AM/FM/SW solutions.

Leveraging Silicon Laboratories' proven and patented digital low intermediate frequency (low-IF) receiver architecture, the Si4835-B31 delivers superior RF performance and interference rejection in AM, FM, and SW bands. The high integration and complete system production test simplifies design-in, increases system quality, and improves manufacturability.

### 4.2. FM Receiver

The Si4835-B31 integrates a low noise amplifier (LNA) supporting the worldwide FM broadcast band (64 to 109 MHz).

Pre-emphasis and de-emphasis is a technique used by FM broadcasters to improve the signal-to-noise ratio of FM receivers by reducing the effects of high frequency interference and noise. When the FM signal is transmitted, a pre-emphasis filter is applied to accentuate the high audio frequencies. All FM receivers incorporate a de-emphasis filter which attenuates high frequencies to restore a flat frequency response. Two time constants are used in various regions. The de-emphasis time constant can be chosen to be 50 or 75  $\mu$ s. Refer to "AN555: Si483x-B/Si4820/24 Antenna, Schematic, Layout, and Design Guidelines"

The Si4835-B31 also has advanced stereo blending that employs adaptive noise suppression. As a signal quality degrades, the Si4835-B31 gradually combines the stereo left and right audio channels to a mono audio signal to maintain optimum sound fidelity under varying reception conditions. The Si4835-B31 can drive a stereo light with the stereo/mono information so that the user can easily discern the signal quality.

# Si4835-B31

---

The stereo light up criteria are defined using both RSSI and the Left and Right separation levels as these two specifications are the primary factors for stereo listening. The criteria can be set between two conditions: the Left and Right channels are separated by more than 6 dB with RSSI at >20 dB or Left and Right channels are separated by more than 12 dB with RSSI at >28 dB. The selection can be set up using different values of the external resistor. Refer to "AN555: Si483x-B/Si4820/24 Antenna, Schematic, Layout, and Design Guidelines."

## 4.3. AM Receiver

The highly integrated Si4835-B31 supports worldwide AM band reception from 504 to 1750 kHz using a digital low-IF architecture with a minimum number of external components and no manual alignment required. This patented architecture allows for high-precision filtering, offering excellent selectivity and SNR with minimum variation across the AM band. The Si4835 supports the worldwide AM band with 5 sub-bands. One of the 5 sub-bands is a universal AM band (AM4, 520–1730 kHz) supporting both 9 kHz and 10 kHz tuning step for all regional AM standards of the world. The Si4835-B31 optimizes sensitivity and rejection of strong interferers, allowing better reception of weak stations.

To offer maximum flexibility, the receiver supports a wide range of ferrite loop sticks from 180–450  $\mu$ H. An air loop antenna is supported by using a transformer to increase the effective inductance from the air loop. Using a 1:5 turn ratio inductor, the inductance is increased by 25 times and easily supports all typical AM air loop antennas, which generally vary between 10 and 20  $\mu$ H.

## 4.4. SW Receiver

The Si4835-B31 supports 16 short wave (SW) band receptions from 5.60 to 22.0 MHz. Si4835-B31 supports extensive short wave features such as minimal discrete components and no factory adjustments. The Si4835-B31 supports using the FM antenna to capture short wave signals. The short wave tuning experience for the B31 has been enhanced compared to the B30 version, allowing users to find the weak short wave stations more easily when tuning quickly across them.

## 4.5. Frequency Tuning

A valid channel can be found by tuning the potentiometer that is connected to the TUNE1 and TUNE2 pin of the Si4835-B31 chip.

To offer easy tuning, the Si4835-B31 also supports a station LED light. It will light up the LED if the RF signal quality passes the LED sensitivity threshold when tuned to a valid station.

## 4.6. Band Select

The Si4835-B31 supports the worldwide AM band with five sub-bands, the US/Europe/Japan/China FM band with five sub-bands, and the SW band with 16 sub-bands. For details on band selection, refer to "AN555: Si483x-B/Si4820/24 Antenna, Schematic, Layout, and Design Guidelines."

## 4.7. Bass and Treble

The Si4835-B31 further supports bass and treble tone control for superior sound quality. Pins 16 and 17 can be configured for tone control, allowing customers to use either two buttons or one slide-switch to adjust the bass and treble. For further configuration details, refer to "AN555: Si483x-B/Si4820/24 Antenna, Schematic, Layout, and Design Guidelines."

## 4.8. Volume Control

The Si4835-B31 not only allows customers to use the traditional PVR wheel volume control through an external speaker amplifier, it also supports direct digital volume control through pins 16 and 17 by using volume up and down buttons. Refer to "AN555: Si483x-B/Si4820/24 Antenna, Schematic, Layout, and Design Guidelines."

## 5. Pin Descriptions: Si4835-B31

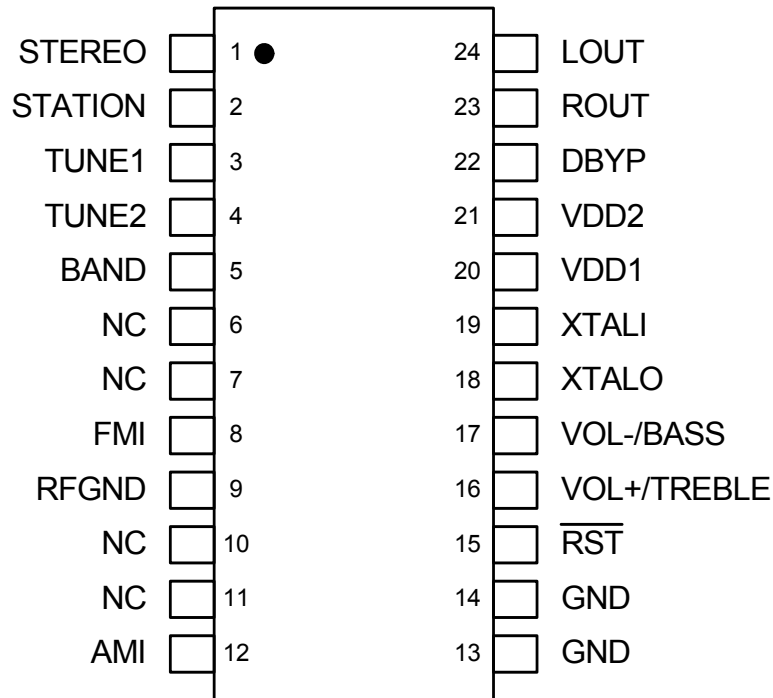

Pin Number(s)	Name	Description
1	STEREO	Stereo indicator
2	STATION	Station indicator
3	TUNE1	Frequency tuning
4	TUNE2	Frequency tuning
5	BAND	Band selection and De-emphasis/Stereo separation selection
6,7	NC	No connect. Leave floating.
8	FMI	FM RF inputs. FMI should be connected to the antenna trace.
9	RFGND	RF ground. Connect to ground plane on PCB.
10,11	NC	Unused. Tie these pins to GND.
12	AMI	AM RF input. AMI should be connected to the AM antenna.
13,14	GND	Ground. Connect to ground plane on PCB.
15	$\overline{\text{RST}}$	Device reset (active low) input
16	VOL+/TREBLE	Volume button up/Treble
17	VOL-/BASS	Volume button down/Bass
18	XTALO	Crystal oscillator output
19	XTALI	Crystal oscillator input
20	VDD1	Supply voltage. May be connected directly to battery.
21	VDD2	Supply voltage. May be connected directly to battery.
22	DBYP	Dedicated bypass for VDD
23	ROUT	Right audio line output in analog output mode
24	LOUT	Left audio line output in analog output mode

# Si4835-B31

---

## 6. Ordering Guide

Part Number*	Description	Package Type	Operating Temperature/Voltage
Si4835-B31-GU	AM/FM/SW Broadcast Radio Receiver	24L SSOP Pb-free	-15 to 85 °C 2.0 to 3.6 V

**\*Note:** Add an "(R)" at the end of the device part number to denote tape and reel option. The devices will typically operate at 25 °C with degraded specifications for  $V_{DD}$  voltage ramped down to 2.0 V.

## 7. Package Markings (Top Marks)

### 7.1. Si4835-B31 Top Marking

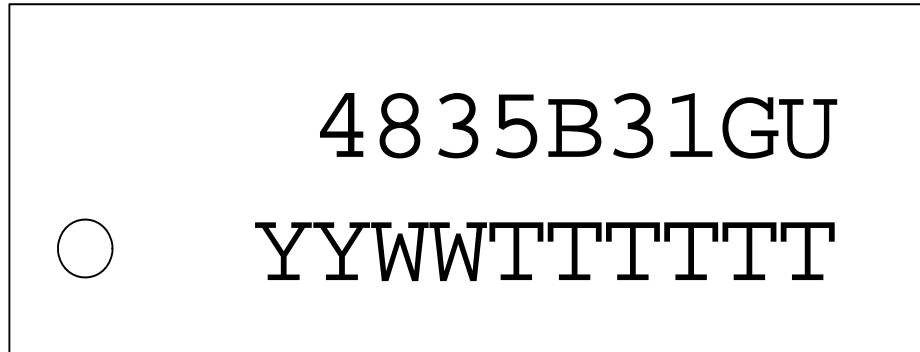

### 7.2. Top Marking Explanation

<b>Mark Method:</b>	YAG Laser	
<b>Line 1 Marking:</b>	Device identifier	4835B31GU = Si4835-B31
<b>Line 2 Marking:</b>	YY = Year WW = Work week TTTTTT = Manufacturing code	Assigned by the Assembly House.

# Si4835-B31

## 8. Package Outline: Si4835-B31

The 24-pin SSOP illustrates the package details for the Si4835-B31. Table 10 lists the values for the dimensions shown in the illustration.

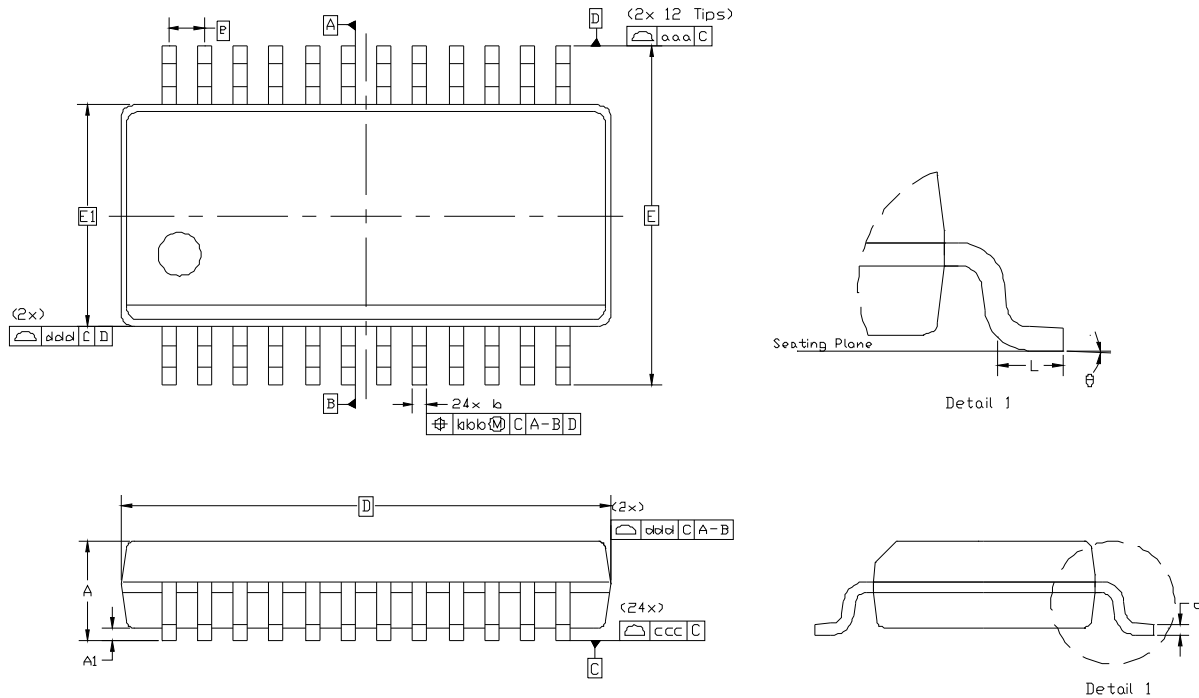

Figure 3. 24-Pin SSOP

Table 10. Package Dimensions

Dimension	Min	Nom	Max
A	—	—	1.75
A1	0.10	—	0.25
b	0.20	—	0.30
c	0.10	—	0.25
D	8.65 BSC		
E	6.00 BSC		
E1	3.90 BSC		
e	0.635 BSC		
L	0.40	—	1.27
θ	0°	—	8°
aaa	0.20		
bbb	0.18		
ccc	0.10		
ddd	0.10		
<b>Notes:</b>			
1. All dimensions shown are in millimeters (mm) unless otherwise noted.			
2. Dimensioning and Tolerancing per ANSI Y14.5M-1994.			
3. This drawing conforms to the JEDEC Solid State Outline MO-137, Variation AE.			
4. Recommended card reflow profile is per the JEDEC/IPC J-STD-020 specification for Small Body Components.			

## 9. PCB Land Pattern: Si4835-B31

Figure 4, "PCB Land Pattern," illustrates the PCB land pattern details for the Si4835-B31-GU SSOP. Table 11 lists the values for the dimensions shown in the illustration.

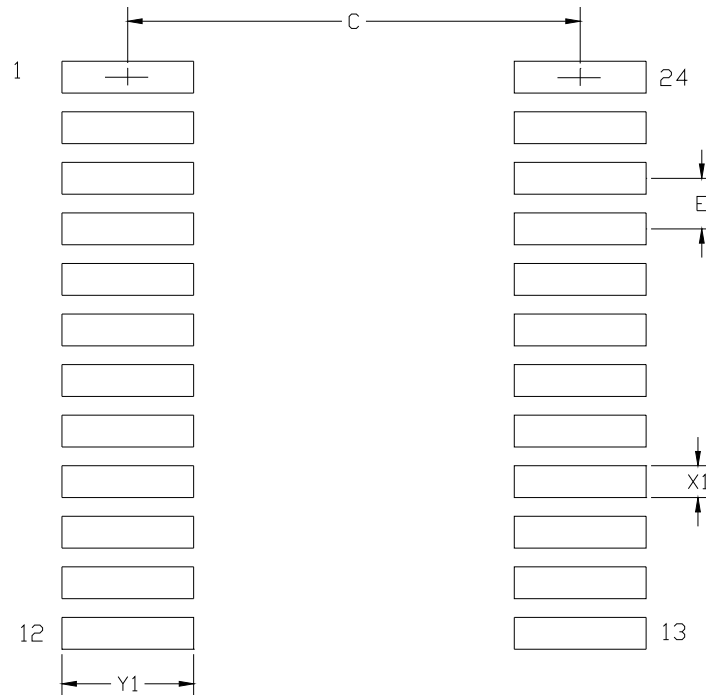

Figure 4. PCB Land Pattern

Table 11. PCB Land Pattern Dimensions

Dimension	Min	Max
C	5.20	5.40
E	0.635 BSC	
X1	0.35	0.45
Y1	1.55	1.75

**General:**

- All dimensions shown are in millimeters (mm) unless otherwise noted.
- This land pattern design is based on the IPC-7351 guidelines.

**Solder Mask Design:**

- All metal pads are to be non-solder mask defined (NSMD). Clearance between the solder mask and the metal pad is to be 60  $\mu\text{m}$  minimum, all the way around the pad.

**Stencil Design:**

- A stainless steel, laser-cut, and electro-polished stencil with trapezoidal walls should be used to assure good solder paste release.
- The stencil thickness should be 0.125 mm (5 mils).
- The ratio of stencil aperture to land pad size should be 1:1 for all perimeter pads.

**Card Assembly:**

- A No-Clean, Type-3 solder paste is recommended.
- The recommended card reflow profile is per the JEDEC/IPC J-STD-020 specification for Small Body Components.

## 10. Additional Reference Resources

Contact your local sales representatives for more information or to obtain copies of the following references:

- EN55020 Compliance Test Certificate
- AN555: Si483x-B/Si4820/24 Antenna, Schematic, Layout, and Design Guidelines
- AN569: Si4831/35/20/24-DEMO Board Test Procedure
- Si4831/35-DEMO Board User's Guide

**NOTES:**

## CONTACT INFORMATION

### Silicon Laboratories Inc.

400 West Cesar Chavez  
Austin, TX 78701  
Tel: 1+(512) 416-8500  
Fax: 1+(512) 416-9669  
Toll Free: 1+(877) 444-3032  
Email: [FMinfo@silabs.com](mailto:FMinfo@silabs.com)  
Internet: [www.silabs.com](http://www.silabs.com)

The information in this document is believed to be accurate in all respects at the time of publication but is subject to change without notice. Silicon Laboratories assumes no responsibility for errors and omissions, and disclaims responsibility for any consequences resulting from the use of information included herein. Additionally, Silicon Laboratories assumes no responsibility for the functioning of undescribed features or parameters. Silicon Laboratories reserves the right to make changes without further notice. Silicon Laboratories makes no warranty, representation or guarantee regarding the suitability of its products for any particular purpose, nor does Silicon Laboratories assume any liability arising out of the application or use of any product or circuit, and specifically disclaims any and all liability, including without limitation consequential or incidental damages. Silicon Laboratories products are not designed, intended, or authorized for use in applications intended to support or sustain life, or for any other application in which the failure of the Silicon Laboratories product could create a situation where personal injury or death may occur. Should Buyer purchase or use Silicon Laboratories products for any such unintended or unauthorized application, Buyer shall indemnify and hold Silicon Laboratories harmless against all claims and damages.

Silicon Laboratories and Silicon Labs are trademarks of Silicon Laboratories Inc.  
Other products or brandnames mentioned herein are trademarks or registered trademarks of their respective holders.