

Document No.	853-0873
ECN No.	95586
Date of issue	January 20, 1989
Status	Product Specification
FAST Products	

FAST 74F537

1-Of-10 Decoder (3-state)

TYPE	TYPICAL PROPAGATION DELAY	TYPICAL SUPPLY CURRENT (TOTAL)
74F537	9 ns	44mA

DESCRIPTION

The 74F537 is one of ten decoder/demultiplexer with four active High BCD inputs and ten mutually exclusive outputs. A Polarity control (P) input determines whether the outputs are active Low or active High. The 'F537 has 3-state outputs, and a High signal on the Output Enable (\overline{OE}) input forces all outputs to the high impedance state. Two input Enables, active High (E_1) and active Low (\overline{E}_0), are available for demultiplexing data to the selected output in either non-inverted or inverted form. Input codes greater than BCD nine causes all outputs to go to the inactive state (i.e., same polarity as the P input).

ORDERING INFORMATION

PACKAGES	COMMERCIAL RANGE $V_{CC} = 5V \pm 10\%$; $T_A = 0^\circ C$ to $+70^\circ C$
20-Pin Plastic DIP	N74F537N
20-Pin Plastic SOL	N74F537D

INPUT AND OUTPUT LOADING AND FAN-OUT TABLE

PINS	DESCRIPTION	74F(U.L.) HIGH/LOW	LOAD VALUE HIGH/LOW
$A_0 - A_3$	Data inputs	1.0/1.0	20 μ A/0.6mA
\overline{E}_0	Enable input (active Low)	1.0/1.0	20 μ A/0.6mA
E_1	Enable input (active High)	1.0/1.0	20 μ A/0.6mA
P	Polarity control input	1.0/1.0	20 μ A/0.6mA
\overline{OE}	Output enable input	1.0/1.0	20 μ A/0.6mA
$Q_0 - Q_9$	Data outputs	150/40	3.0mA/24mA

NOTE:

One (1.0) FAST Unit Load is defined as: 20 μ A in the High state and 0.6mA in the Low state.

PIN CONFIGURATION

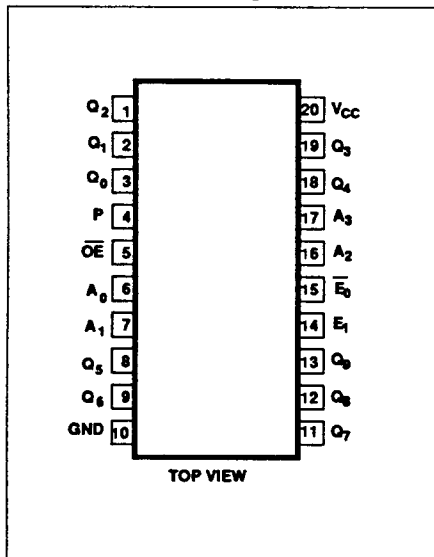

LOGIC SYMBOL

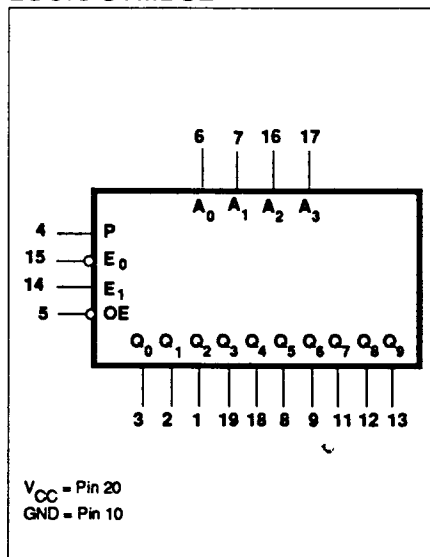

LOGIC SYMBOL (IEEE/IEC)

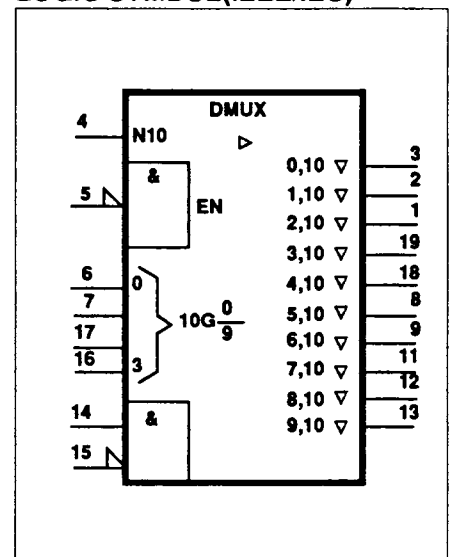

Decoder

FAST 74F537

LOGIC DIAGRAM

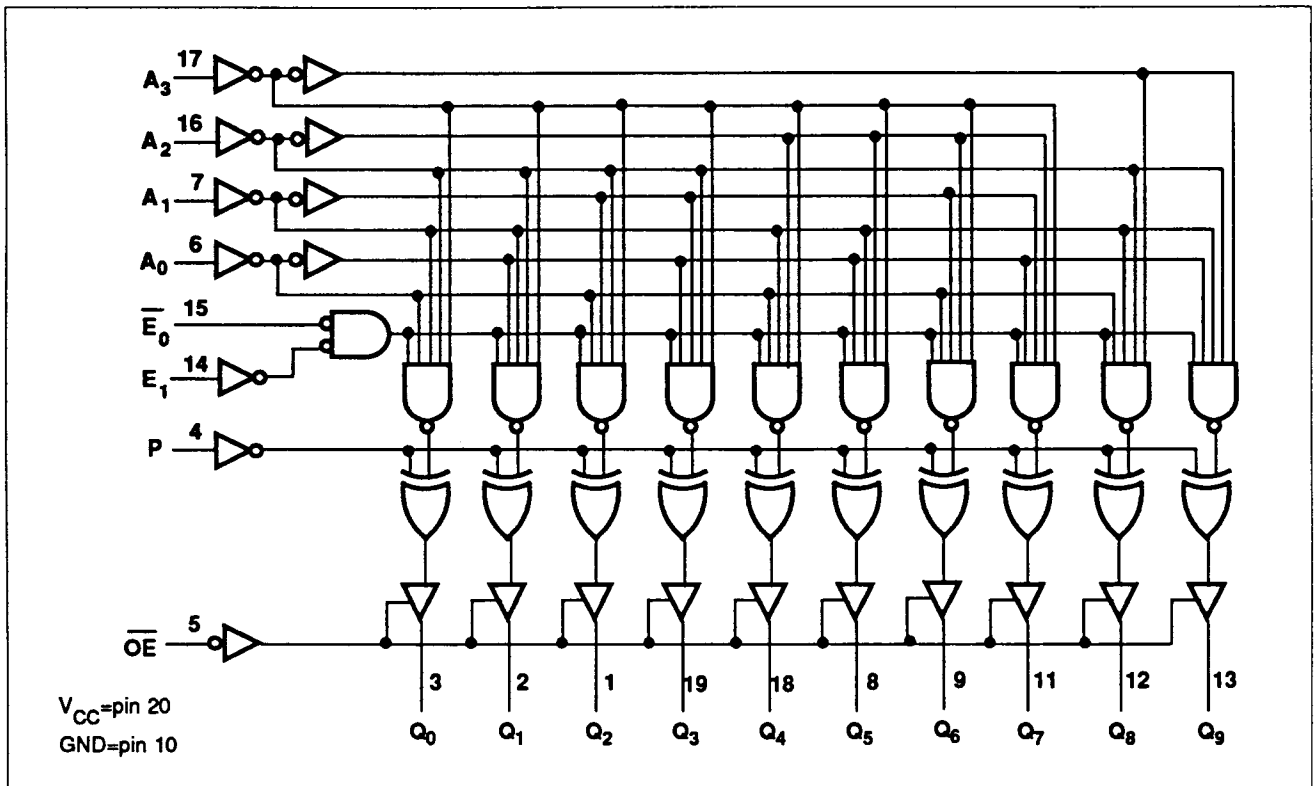

FUNCTION TABLE

INPUTS								OUTPUTS												OPERATING MODE
OE	E ₀	E ₁	A ₃	A ₂	A ₁	A ₀		Q ₀	Q ₁	Q ₂	Q ₃	Q ₄	Q ₅	Q ₆	Q ₇	Q ₈	Q ₉			
H	X	X	X	X	X	X	X	Z	Z	Z	Z	Z	Z	Z	Z	Z	Z	High impedance		
L	H	X	X	X	X	X	X	Outputs equal P input										Disable		
L	L	H	L	L	L	L	L	H	L	L	L	L	L	L	L	L	L	Active High output (P=L)		
L	L	H	L	L	L	H	L	L	H	L	L	L	L	L	L	L	L			
L	L	H	L	L	H	L	L	L	L	L	L	L	H	L	L	L	L			
L	L	H	L	L	H	H	L	L	L	L	L	L	L	L	L	H	L			
L	L	H	H	L	L	L	L	L	L	L	L	L	L	L	L	L	L	Active Low output (P=H)		
L	L	H	H	L	L	H	L	L	L	L	L	L	L	L	L	L	L			
L	L	H	H	X	H	X	L	L	L	L	L	L	L	L	L	L	L			
L	L	H	H	L	X	X	L	L	L	L	L	L	L	L	L	L	L			
L	L	H	L	L	L	L	L	L	H	H	H	H	H	H	H	H	H	Active Low output (P=H)		
L	L	H	L	L	L	H	L	L	H	H	H	H	H	H	H	H	H			
L	L	H	L	L	H	L	L	H	H	L	H	H	H	H	H	H	H			
L	L	H	L	H	L	H	L	H	H	H	H	H	L	H	H	H	H			
L	L	H	L	H	H	L	L	H	H	H	H	H	H	L	H	H	H	Active Low output (P=H)		
L	L	H	L	H	H	H	L	H	H	H	H	H	H	H	H	H	H			
L	L	H	H	X	H	X	L	L	L	L	L	L	L	L	L	L	L			
L	L	H	H	H	X	X	L	L	L	L	L	L	L	L	L	L	L			

H = High voltage level
L = Low voltage level
X = Don't care

Decoder

FAST 74F537

ABSOLUTE MAXIMUM RATINGS (Operation beyond the limits set forth in this table may impair the useful life of the device. Unless otherwise noted these limits are over the operating free-air temperature range.)

SYMBOL	PARAMETER	RATING	UNIT
V_{CC}	Supply voltage	-0.5 to +7.0	V
V_{IN}	Input voltage	-0.5 to +7.0	V
I_{IN}	Input current	-30 to +5	mA
V_{OUT}	Voltage applied to output in High output state	-0.5 to V_{CC}	V
I_{OUT}	Current applied to output in Low output state	48	mA
T_A	Operating free-air temperature range	0 to +70	°C
T_{STG}	Storage temperature	-65 to +150	°C

RECOMMENDED OPERATING CONDITIONS

SYMBOL	PARAMETER	LIMITS			UNIT
		Min	Nom	Max	
V_{CC}	Supply voltage	4.5	5.0	5.5	V
V_H	High-level input voltage	2.0			V
V_L	Low-level input voltage			0.8	V
I_{IK}	Input clamp current			-18	mA
I_{OH}	High-level output current			-3	mA
I_{OL}	Low-level output current			24	mA
T_A	Operating free-air temperature range	0		70	°C

DC ELECTRICAL CHARACTERISTICS (Over recommended operating free-air temperature range unless otherwise noted.)

SYMBOL	PARAMETER	TEST CONDITIONS ¹	LIMITS			UNIT	
			Min	Typ ²	Max		
V_{OH}	High-level output voltage	$V_{CC} = \text{MIN}, V_{IL} = \text{MAX}$	$\pm 10\%V_{CC}$	2.4		V	
		$V_{IH} = \text{MIN}, I_{OH} = \text{MAX}$	$\pm 5\%V_{CC}$	2.7	3.3	V	
V_{OL}	Low-level output voltage	$V_{CC} = \text{MIN}, V_{IL} = \text{MAX}$	$\pm 10\%V_{CC}$		0.35	0.50	V
		$V_{IH} = \text{MIN}, I_{OL} = \text{MAX}$	$\pm 5\%V_{CC}$		0.35	0.50	V
V_{IK}	Input clamp voltage	$V_{CC} = \text{MIN}, I_I = I_{IK}$		-0.73	-1.2	V	
I_I	Input current at maximum input voltage	$V_{CC} = \text{MAX}, V_I = 7.0V$			100	μA	
I_{IH}	High-level input current	$V_{CC} = \text{MAX}, V_I = 2.7V$			20	μA	
I_{IL}	Low-level input current	$V_{CC} = \text{MAX}, V_I = 0.5V$			-0.6	mA	
I_{OZH}	Off-state output current, High-level voltage applied	$V_{CC} = \text{MAX}, V_O = 2.7V$			50	μA	
I_{OZL}	Off-state output current, Low-level voltage applied	$V_{CC} = \text{MAX}, V_O = 0.5V$			-50	μA	
I_{OS}	Short circuit output current ³	$V_{CC} = \text{MAX}$		-60	-150	mA	
I_{CC}	Supply current (total)	$V_{CC} = \text{MAX}$		44	66	mA	

NOTES:

- For conditions shown as MIN or MAX, use the appropriate value specified under recommended operating conditions for the applicable type.
- All typical values are at $V_{CC} = 5V, T_A = 25^\circ C$.
- Not more than one output should be shorted at a time. For testing I_{OS} , the use of high-speed test apparatus and/or sample-and-hold techniques are preferable in order to minimize internal heating and more accurately reflect operational values. Otherwise, prolonged shorting of a High output may raise the chip temperature well above normal and thereby cause invalid readings in other parameter tests. In any sequence of parameter tests, I_{OS} tests should be performed last.

Decoder

FAST 74F537

AC ELECTRICAL CHARACTERISTICS

SYMBOL	PARAMETER	TEST CONDITION	LIMITS					UNIT
			T _A = +25°C V _{CC} = 5V C _L = 50pF R _L = 500Ω			T _A = 0°C to +70°C V _{CC} = 5V ±10% C _L = 50pF R _L = 500Ω		
			Min	Typ	Max	Min	Max	
t _{PLH} t _{PHL}	Propagation delay A _n to Q _n	Waveform 1	4.5 3.0	9.0 7.5	14.0 11.0	4.5 3.0	16.0 12.0	ns
t _{PLH} t _{PHL}	Propagation delay E ₀ to Q _n	Waveform 2	4.0 3.0	8.0 8.0	11.0 11.0	4.0 3.0	12.0 12.0	ns
t _{PLH} t _{PHL}	Propagation delay E ₁ to Q _n	Waveform 2	6.0 4.0	8.5 8.5	11.5 11.5	6.0 4.0	13.0 12.5	ns
t _{PLH} t _{PHL}	Propagation delay P to Q _n	Waveform 1	5.0 3.5	12.5 6.5	16.0 10.0	5.0 3.5	17.0 11.0	ns
t _{PZH} t _{PZL}	Output Enable time OE to Q _n	Waveform 3 Waveform 4	2.5 4.0	4.5 5.5	7.0 8.0	2.5 4.0	8.0 9.0	ns
t _{PHZ} t _{PLZ}	Output Disable time OE to Q _n	Waveform 3 Waveform 4	1.5 2.0	3.0 4.0	6.0 6.5	1.0 2.0	7.0 7.0	ns

AC WAVEFORMS

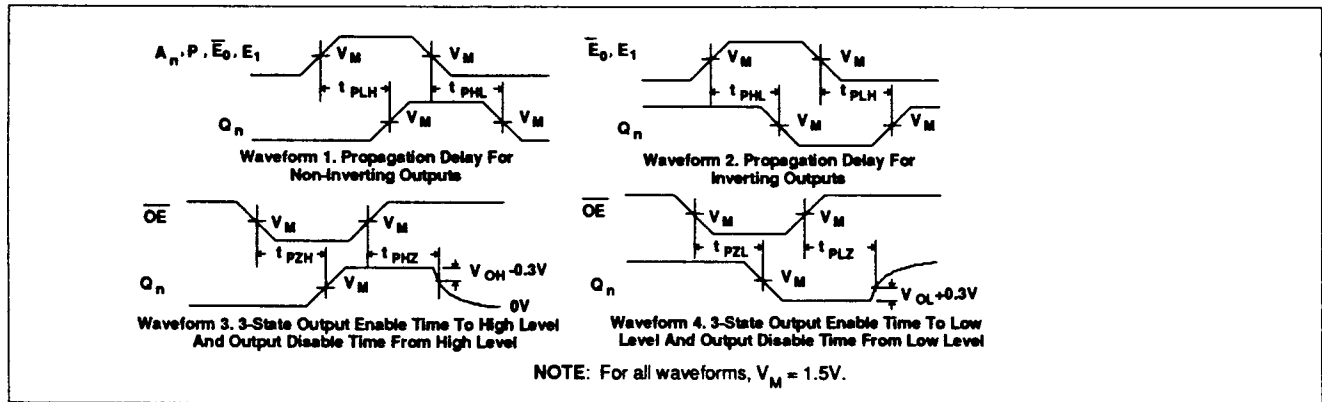

TEST CIRCUIT AND WAVEFORMS

Test Circuit For 3-State Outputs

TEST	SWITCH
t _{PLZ} , t _{PZL}	closed
All other	open

DEFINITIONS

R_L = Load resistor; see AC CHARACTERISTICS for value.

C_L = Load capacitance includes jig and probe capacitance; see AC CHARACTERISTICS for value.

R_T = Termination resistance should be equal to Z_{OUT} of pulse generators.

Input Pulse Definition

V_M = 1.5V

FAMILY	INPUT PULSE REQUIREMENTS				
	Amplitude	Rep. Rate	t _w	t _{TLH}	t _{THL}
74F	3.0V	1MHz	500ns	2.5ns	2.5ns