

EconoPACK™4 モジュール トレンチ/フィールドストップ IGBT4 and エミッターコントロール4 diode内蔵 and pressFIT / すでに塗布されたサーマルグリース

EconoPACK™4 module with Trench/Fieldstop IGBT4 and Emitter Controlled 4 diode and PressFIT / pre-applied Thermal Interface Material

## 暫定データ / Preliminary Data

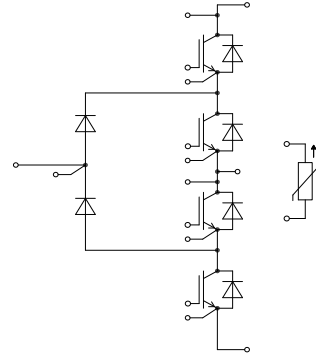
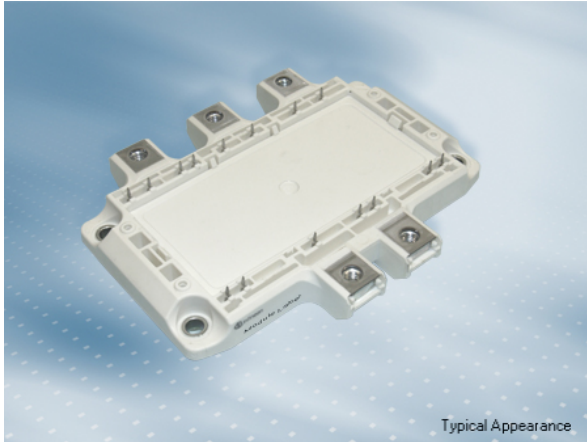

$V_{CES} = 650V$

$I_{C\ nom} = 300A / I_{CRM} = 600A$

### 一般応用

- 3レベル アプリケーション

### Typical Applications

- 3-level-applications

### 電気的特性

- 650Vに増加したブロッキング電圧
- 拡張された動作温度  $T_{vj\ op}$
- $T_{vj\ op} = 150^{\circ}C$
- トレンチ IGBT 4
- 正温度特性を持った  $V_{CESat}$  飽和電圧

### Electrical Features

- Increased blocking voltage capability up to 650V
- Extended operating temperature  $T_{vj\ op}$
- $T_{vj\ op} = 150^{\circ}C$
- Trench IGBT 4
- $V_{CESat}$  with positive temperature coefficient

### 機械的特性

- 4 kV AC 1分 絶縁耐圧
- 強いメカニカルロバストネス
- 内蔵されたNTCサーミスタ
- 絶縁されたベースプレート
- 標準ハウジング
- すでに塗布されたサーマルグリース

### Mechanical Features

- 4 kV AC 1min insulation
- High mechanical robustness
- Integrated NTC temperature sensor
- Isolated base plate
- Standard housing
- Pre-applied Thermal Interface Material

## Module Label Code

Barcode Code 128



DMX - Code



Content of the Code

| Content of the Code        | Digit   |
|----------------------------|---------|
| Module Serial Number       | 1 - 5   |
| Module Material Number     | 6 - 11  |
| Production Order Number    | 12 - 19 |
| Datecode (Production Year) | 20 - 21 |
| Datecode (Production Week) | 22 - 23 |

暫定データ  
 Preliminary Data

 IGBT- インバータ / IGBT, Inverter  
 最大定格 / Maximum Rated Values

|  |  |                   |       |   |
|--|--|-------------------|-------|---|
| コレクタ・エミッタ間電圧<br>Collector-emitter voltage          | $T_{vj} = 25^{\circ}\text{C}$                                | $V_{CES}$         | 650   | V |
| コレクタ電流<br>Implemented collector current            |  | $I_{CN}$          | 300   | A |
| 連続DCコレクタ電流<br>Continuous DC collector current      | $T_H = 25^{\circ}\text{C}, T_{vj\max} = 175^{\circ}\text{C}$ | $I_{C\text{nom}}$ | 280   | A |
| 繰り返しピークコレクタ電流<br>Repetitive peak collector current | $t_p = 1\text{ms}$   | $I_{CRM}$         | 600   | A |
| ゲート・エミッタ間ピーク電圧<br>Gate-emitter peak voltage        |  | $V_{GES}$         | +/-20 | V |

## 電气的特性 / Characteristic Values

|  |   |   | min.               | typ.                 | max.  |   |
|--|---|---|--------------------|----------------------|-------|---|
| コレクタ・エミッタ間飽和電圧<br>Collector-emitter saturation voltage         | $I_C = 280\text{A}, V_{GE} = 15\text{V}$<br>$I_C = 280\text{A}, V_{GE} = 15\text{V}$<br>$I_C = 280\text{A}, V_{GE} = 15\text{V}$  | $T_{vj} = 25^{\circ}\text{C}$<br>$T_{vj} = 125^{\circ}\text{C}$<br>$T_{vj} = 150^{\circ}\text{C}$               | $V_{CE\text{sat}}$ | 1,50<br>1,65<br>1,70 | 1,75  | V<br>V<br>V                                     |
| ゲート・エミッタ間しきい値電圧<br>Gate threshold voltage                      | $I_C = 4,80\text{mA}, V_{CE} = V_{GE}, T_{vj} = 25^{\circ}\text{C}$   |   | $V_{G\text{eth}}$  | 5,00                 | 5,80  | 6,50 V  |
| ゲート電荷量<br>Gate charge  | $V_{GE} = -15\text{V} \dots +15\text{V}$  |   | $Q_G$              | 3,00                 |       | $\mu\text{C}$                                   |
| 内蔵ゲート抵抗<br>Internal gate resistor                              | $T_{vj} = 25^{\circ}\text{C}$   |   | $R_{G\text{int}}$  | 1,0                  |       | $\Omega$  |
| 入力容量<br>Input capacitance                                      | $f = 1\text{MHz}, T_{vj} = 25^{\circ}\text{C}, V_{CE} = 25\text{V}, V_{GE} = 0\text{V}$   |   | $C_{\text{ies}}$   | 18,5                 |       | nF  |
| 帰還容量<br>Reverse transfer capacitance                           | $f = 1\text{MHz}, T_{vj} = 25^{\circ}\text{C}, V_{CE} = 25\text{V}, V_{GE} = 0\text{V}$   |   | $C_{\text{res}}$   | 0,57                 |       | nF  |
| コレクタ・エミッタ間遮断電流<br>Collector-emitter cut-off current            | $V_{CE} = 650\text{V}, V_{GE} = 0\text{V}, T_{vj} = 25^{\circ}\text{C}$   |   | $I_{CES}$          |                      | 1,0   | mA  |
| ゲート・エミッタ間漏れ電流<br>Gate-emitter leakage current                  | $V_{CE} = 0\text{V}, V_{GE} = 20\text{V}, T_{vj} = 25^{\circ}\text{C}$  |   | $I_{GES}$          |                      | 400   | nA  |
| ターンオン遅れ時間 (誘導負荷)<br>Turn-on delay time, inductive load         | $I_C = 280\text{A}, V_{CE} = 300\text{V}$<br>$V_{GE} = \pm 15\text{V}$<br>$R_{G\text{on}} = 2,0\Omega$  | $T_{vj} = 25^{\circ}\text{C}$<br>$T_{vj} = 125^{\circ}\text{C}$<br>$T_{vj} = 150^{\circ}\text{C}$               | $t_{d\text{on}}$   | 0,09<br>0,11<br>0,12 |       | $\mu\text{s}$<br>$\mu\text{s}$<br>$\mu\text{s}$ |
| ターンオン上昇時間 (誘導負荷)<br>Rise time, inductive load                  | $I_C = 280\text{A}, V_{CE} = 300\text{V}$<br>$V_{GE} = \pm 15\text{V}$<br>$R_{G\text{on}} = 2,0\Omega$  | $T_{vj} = 25^{\circ}\text{C}$<br>$T_{vj} = 125^{\circ}\text{C}$<br>$T_{vj} = 150^{\circ}\text{C}$               | $t_r$              | 0,05<br>0,06<br>0,06 |       | $\mu\text{s}$<br>$\mu\text{s}$<br>$\mu\text{s}$ |
| ターンオフ遅れ時間 (誘導負荷)<br>Turn-off delay time, inductive load        | $I_C = 280\text{A}, V_{CE} = 300\text{V}$<br>$V_{GE} = \pm 15\text{V}$<br>$R_{G\text{off}} = 2,0\Omega$   | $T_{vj} = 25^{\circ}\text{C}$<br>$T_{vj} = 125^{\circ}\text{C}$<br>$T_{vj} = 150^{\circ}\text{C}$               | $t_{d\text{off}}$  | 0,49<br>0,52<br>0,53 |       | $\mu\text{s}$<br>$\mu\text{s}$<br>$\mu\text{s}$ |
| ターンオフ下降時間 (誘導負荷)<br>Fall time, inductive load                  | $I_C = 280\text{A}, V_{CE} = 300\text{V}$<br>$V_{GE} = \pm 15\text{V}$<br>$R_{G\text{off}} = 2,0\Omega$   | $T_{vj} = 25^{\circ}\text{C}$<br>$T_{vj} = 125^{\circ}\text{C}$<br>$T_{vj} = 150^{\circ}\text{C}$               | $t_f$              | 0,05<br>0,07<br>0,07 |       | $\mu\text{s}$<br>$\mu\text{s}$<br>$\mu\text{s}$ |
| ターンオンスイッチング損失<br>Turn-on energy loss per pulse                 | $I_C = 280\text{A}, V_{CE} = 300\text{V}, L_S = 30\text{nH}$<br>$V_{GE} = \pm 15\text{V}, di/dt = 3300\text{A}/\mu\text{s} (T_{vj} = 150^{\circ}\text{C})$<br>$R_{G\text{on}} = 2,0\Omega$  | $T_{vj} = 25^{\circ}\text{C}$<br>$T_{vj} = 125^{\circ}\text{C}$<br>$T_{vj} = 150^{\circ}\text{C}$               | $E_{\text{on}}$    | 1,30<br>1,90<br>2,40 |       | mJ<br>mJ<br>mJ                                  |
| ターンオフスイッチング損失<br>Turn-off energy loss per pulse                | $I_C = 280\text{A}, V_{CE} = 300\text{V}, L_S = 30\text{nH}$<br>$V_{GE} = \pm 15\text{V}, du/dt = 3300\text{V}/\mu\text{s} (T_{vj} = 150^{\circ}\text{C})$<br>$R_{G\text{off}} = 2,0\Omega$ | $T_{vj} = 25^{\circ}\text{C}$<br>$T_{vj} = 125^{\circ}\text{C}$<br>$T_{vj} = 150^{\circ}\text{C}$               | $E_{\text{off}}$   | 13,0<br>16,0<br>17,0 |       | mJ<br>mJ<br>mJ                                  |
| 短絡電流<br>SC data  | $V_{GE} \leq 15\text{V}, V_{CC} = 360\text{V}$<br>$V_{CE\text{max}} = V_{CES} - L_{SCE} \cdot di/dt$  | $t_p \leq 10\mu\text{s}, T_{vj} = 25^{\circ}\text{C}$<br>$t_p \leq 10\mu\text{s}, T_{vj} = 150^{\circ}\text{C}$ | $I_{SC}$           | 1500<br>1200         |       | A<br>A  |
| ジャンクション・ヒートシンク間熱抵抗<br>Thermal resistance, junction to heatsink | IGBT部 (1素子当り) / per IGBT<br>valid with IFX pre-applied thermal interface material   |   | $R_{thJH}$         |                      | 0,250 | K/W   |
| 動作温度<br>Temperature under switching conditions                 |   |   | $T_{vj\text{op}}$  | -40                  | 150   | $^{\circ}\text{C}$                              |

## 暫定データ Preliminary Data

### Diode、インバータ / Diode, Inverter 最大定格 / Maximum Rated Values

|  |  |           |              |  |
|--|--|-----------|--------------|--|
| ピーク繰返し逆電圧<br>Repetitive peak reverse voltage | $T_{vj} = 25^{\circ}\text{C}$  | $V_{RRM}$ | 650          | V  |
| 順電流<br>Implemented forward current           |  | $I_{FN}$  | 300          | A  |
| 連続DC電流<br>Continuous DC forward current      |  | $I_F$     | 280          | A  |
| ピーク繰返し順電流<br>Repetitive peak forward current | $t_p = 1 \text{ ms}$   | $I_{FRM}$ | 600          | A  |
| 電流二乗時間積<br>$I^2t$ - value                    | $V_R = 0 \text{ V}, t_p = 10 \text{ ms}, T_{vj} = 125^{\circ}\text{C}$<br>$V_R = 0 \text{ V}, t_p = 10 \text{ ms}, T_{vj} = 150^{\circ}\text{C}$ | $I^2t$    | 6000<br>5600 | $\text{A}^2\text{s}$<br>$\text{A}^2\text{s}$ |

### 電気的特性 / Characteristic Values

|  |  |   | min.        | typ.                 | max.  |   |
|--|--|---|-------------|----------------------|-------|---|
| 順電圧<br>Forward voltage   | $I_F = 280 \text{ A}, V_{GE} = 0 \text{ V}$<br>$I_F = 280 \text{ A}, V_{GE} = 0 \text{ V}$<br>$I_F = 280 \text{ A}, V_{GE} = 0 \text{ V}$      | $T_{vj} = 25^{\circ}\text{C}$<br>$T_{vj} = 125^{\circ}\text{C}$<br>$T_{vj} = 150^{\circ}\text{C}$ | $V_F$       | 1,50<br>1,45<br>1,40 | 1,90  | V<br>V<br>V                                     |
| ピーク逆回復電流<br>Peak reverse recovery current                      | $I_F = 280 \text{ A}, -di_F/dt = 3300 \text{ A}/\mu\text{s} (T_{vj}=150^{\circ}\text{C})$<br>$V_R = 300 \text{ V}$<br>$V_{GE} = -15 \text{ V}$ | $T_{vj} = 25^{\circ}\text{C}$<br>$T_{vj} = 125^{\circ}\text{C}$<br>$T_{vj} = 150^{\circ}\text{C}$ | $I_{RM}$    | 130<br>190<br>200    |       | A<br>A<br>A                                     |
| 逆回復電荷量<br>Recovered charge                                     | $I_F = 280 \text{ A}, -di_F/dt = 3300 \text{ A}/\mu\text{s} (T_{vj}=150^{\circ}\text{C})$<br>$V_R = 300 \text{ V}$<br>$V_{GE} = -15 \text{ V}$ | $T_{vj} = 25^{\circ}\text{C}$<br>$T_{vj} = 125^{\circ}\text{C}$<br>$T_{vj} = 150^{\circ}\text{C}$ | $Q_r$       | 9,00<br>20,0<br>23,0 |       | $\mu\text{C}$<br>$\mu\text{C}$<br>$\mu\text{C}$ |
| 逆回復損失<br>Reverse recovery energy                               | $I_F = 280 \text{ A}, -di_F/dt = 3300 \text{ A}/\mu\text{s} (T_{vj}=150^{\circ}\text{C})$<br>$V_R = 300 \text{ V}$<br>$V_{GE} = -15 \text{ V}$ | $T_{vj} = 25^{\circ}\text{C}$<br>$T_{vj} = 125^{\circ}\text{C}$<br>$T_{vj} = 150^{\circ}\text{C}$ | $E_{rec}$   | 3,25<br>5,90<br>6,80 |       | mJ<br>mJ<br>mJ                                  |
| ジャンクション・ヒートシンク間熱抵抗<br>Thermal resistance, junction to heatsink | /Diode ( 1 素子当り ) / per diode<br>valid with IFX pre-applied thermal interface material   |   | $R_{thJH}$  |                      | 0,369 | K/W   |
| 動作温度<br>Temperature under switching conditions                 |  |   | $T_{vj op}$ | -40                  | 150   | $^{\circ}\text{C}$                              |

### ダイオード、スリー・レベル / Diode, 3-Level 最大定格 / Maximum Rated Values

|  |  |           |              |  |
|--|--|-----------|--------------|--|
| ピーク繰返し逆電圧<br>Repetitive peak reverse voltage | $T_{vj} = 25^{\circ}\text{C}$  | $V_{RRM}$ | 650          | V  |
| 順電流<br>Implemented forward current           |  | $I_{FN}$  | 300          | A  |
| 連続DC電流<br>Continuous DC forward current      |  | $I_F$     | 280          | A  |
| ピーク繰返し順電流<br>Repetitive peak forward current | $t_p = 1 \text{ ms}$   | $I_{FRM}$ | 600          | A  |
| 電流二乗時間積<br>$I^2t$ - value                    | $V_R = 0 \text{ V}, t_p = 10 \text{ ms}, T_{vj} = 125^{\circ}\text{C}$<br>$V_R = 0 \text{ V}, t_p = 10 \text{ ms}, T_{vj} = 150^{\circ}\text{C}$ | $I^2t$    | 6000<br>5600 | $\text{A}^2\text{s}$<br>$\text{A}^2\text{s}$ |

### 電気的特性 / Characteristic Values

|  |   |   | min.        | typ.                 | max.  |   |
|--|---|---|-------------|----------------------|-------|---|
| 順電圧<br>Forward voltage   | $I_F = 280 \text{ A}, V_{GE} = 0 \text{ V}$<br>$I_F = 280 \text{ A}, V_{GE} = 0 \text{ V}$<br>$I_F = 280 \text{ A}, V_{GE} = 0 \text{ V}$ | $T_{vj} = 25^{\circ}\text{C}$<br>$T_{vj} = 125^{\circ}\text{C}$<br>$T_{vj} = 150^{\circ}\text{C}$ | $V_F$       | 1,50<br>1,45<br>1,40 | 1,90  | V<br>V<br>V                                     |
| ピーク逆回復電流<br>Peak reverse recovery current                      | $I_F = 280 \text{ A}, -di_F/dt = 3300 \text{ A}/\mu\text{s} (T_{vj}=150^{\circ}\text{C})$<br>$V_R = 300 \text{ V}$                        | $T_{vj} = 25^{\circ}\text{C}$<br>$T_{vj} = 125^{\circ}\text{C}$<br>$T_{vj} = 150^{\circ}\text{C}$ | $I_{RM}$    | 130<br>190<br>200    |       | A<br>A<br>A                                     |
| 逆回復電荷量<br>Recovered charge                                     | $I_F = 280 \text{ A}, -di_F/dt = 3300 \text{ A}/\mu\text{s} (T_{vj}=150^{\circ}\text{C})$<br>$V_R = 300 \text{ V}$                        | $T_{vj} = 25^{\circ}\text{C}$<br>$T_{vj} = 125^{\circ}\text{C}$<br>$T_{vj} = 150^{\circ}\text{C}$ | $Q_r$       | 9,00<br>20,0<br>23,0 |       | $\mu\text{C}$<br>$\mu\text{C}$<br>$\mu\text{C}$ |
| 逆回復損失<br>Reverse recovery energy                               | $I_F = 280 \text{ A}, -di_F/dt = 3300 \text{ A}/\mu\text{s} (T_{vj}=150^{\circ}\text{C})$<br>$V_R = 300 \text{ V}$                        | $T_{vj} = 25^{\circ}\text{C}$<br>$T_{vj} = 125^{\circ}\text{C}$<br>$T_{vj} = 150^{\circ}\text{C}$ | $E_{rec}$   | 3,25<br>5,90<br>6,80 |       | mJ<br>mJ<br>mJ                                  |
| ジャンクション・ヒートシンク間熱抵抗<br>Thermal resistance, junction to heatsink | /Diode ( 1 素子当り ) / per diode<br>valid with IFX pre-applied thermal interface material  |   | $R_{thJH}$  |                      | 0,369 | K/W   |
| 動作温度<br>Temperature under switching conditions                 |   |   | $T_{vj op}$ | -40                  | 150   | $^{\circ}\text{C}$                              |

## 暫定データ Preliminary Data

### NTC-サーミスタ / NTC-Thermistor 電気的特性 / Characteristic Values

|                              |  | min.         | typ. | max. |            |
|------------------------------|--|--------------|------|------|------------|
| 定格抵抗値<br>Rated resistance    | $T_{NTC} = 25^{\circ}\text{C}$                                 | $R_{25}$     | 5,00 |      | k $\Omega$ |
| R100の偏差<br>Deviation of R100 | $T_{NTC} = 100^{\circ}\text{C}, R_{100} = 493 \Omega$          | $\Delta R/R$ | -5   | 5    | %          |
| 損失<br>Power dissipation      | $T_{NTC} = 25^{\circ}\text{C}$                                 | $P_{25}$     |      | 20,0 | mW         |
| B-定数<br>B-value              | $R_2 = R_{25} \exp [B_{25/50}(1/T_2 - 1/(298,15 \text{ K}))]$  | $B_{25/50}$  | 3375 |      | K          |
| B-定数<br>B-value              | $R_2 = R_{25} \exp [B_{25/80}(1/T_2 - 1/(298,15 \text{ K}))]$  | $B_{25/80}$  | 3411 |      | K          |
| B-定数<br>B-value              | $R_2 = R_{25} \exp [B_{25/100}(1/T_2 - 1/(298,15 \text{ K}))]$ | $B_{25/100}$ | 3433 |      | K          |

適切なアプリケーションノートによる仕様  
Specification according to the valid application note.

### モジュール / Module

|   |  | min.        | typ.                    | max. |                    |
|---|--|-------------|-------------------------|------|--------------------|
| 絶縁耐圧<br>Isolation test voltage                            | RMS, f = 50 Hz, t = 1 min.   | $V_{ISOL}$  | 4,0                     |      | kV                 |
| ベースプレート材質<br>Material of module baseplate                 |  |             | Cu                      |      |                    |
| 内部絶縁<br>Internal isolation                                | 基礎絶縁 (クラス1, IEC 61140)<br>basic insulation (class 1, IEC 61140)                                  |             | $\text{Al}_2\text{O}_3$ |      |                    |
| 沿面距離<br>Creepage distance                                 | 連絡方法 - ヒートシンク / terminal to heatsink<br>連絡方法 - 連絡方法 / terminal to terminal                       |             | 25,0<br>12,5            |      | mm                 |
| 空間距離<br>Clearance   | 連絡方法 - ヒートシンク / terminal to heatsink<br>連絡方法 - 連絡方法 / terminal to terminal                       |             | 11,0<br>7,0             |      | mm                 |
| 相対トラッキング指数<br>Comperative tracking index                  |  | CTI         | > 200                   |      |                    |
| min. typ. max.  |  |             |                         |      |                    |
| 内部インダクタンス<br>Stray inductance module                      |  | $L_{sCE}$   | 45                      |      | nH                 |
| 保存温度<br>Storage temperature                               |  | $T_{stg}$   | -40                     | 125  | $^{\circ}\text{C}$ |
| 最大ベース・プレート動作温度<br>Maximum baseplate operation temperature |  | $T_{BPmax}$ |                         | 125  | $^{\circ}\text{C}$ |
| 取り付けネジ締め付けトルク<br>Mounting torque for modul mounting       | 取り付けネジ M5<br>適切なアプリケーションノートによるマウンティング<br>Screw M5 - Mounting according to valid application note | M           | 3,00                    | 6,00 | Nm                 |
| 主端子ネジ締め付けトルク<br>Terminal connection torque                | 取り付けネジ M6<br>適切なアプリケーションノートによるマウンティング<br>Screw M6 - Mounting according to valid application note | M           | 3,0                     | -    | 6,0 Nm             |
| 質量<br>Weight  |  | G           | 400                     |      | g                  |

Lagerung und Transport von Modulen mit TIM => siehe AN2012-07  
Storage and shipment of modules with TIM => see AN2012-07

## 暫定データ Preliminary Data

出力特性 IGBT- インバータ (Typical)  
output characteristic IGBT, Inverter (typical)

$I_C = f(V_{CE})$   
 $V_{GE} = 15\text{ V}$

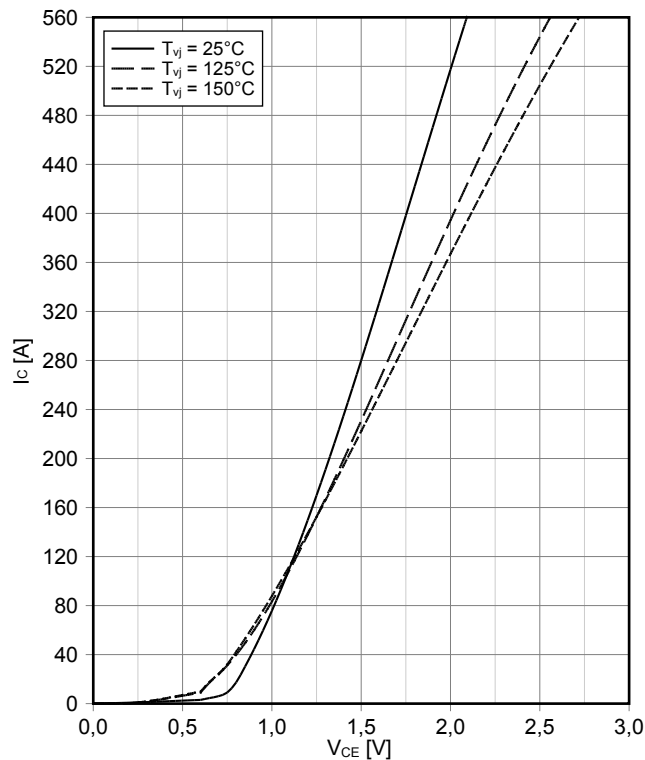

出力特性 IGBT- インバータ (Typical)  
output characteristic IGBT, Inverter (typical)

$I_C = f(V_{CE})$   
 $T_{vj} = 150^\circ\text{C}$

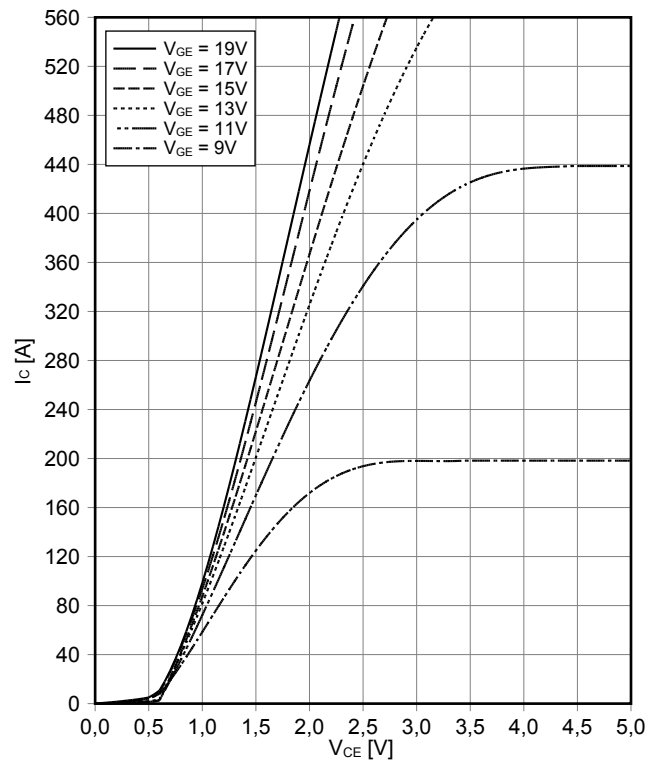

伝達特性 IGBT- インバータ (Typical)  
transfer characteristic IGBT, Inverter (typical)

$I_C = f(V_{GE})$   
 $V_{CE} = 20\text{ V}$

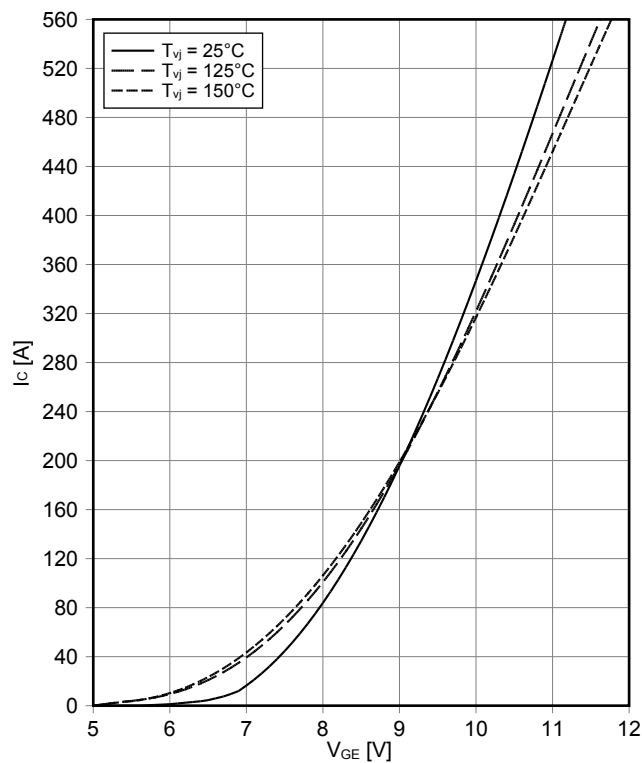

スイッチング損失 IGBT- インバータ (Typical)  
switching losses IGBT, Inverter (typical)

$E_{on} = f(I_C)$ ,  $E_{off} = f(I_C)$   
 $V_{GE} = \pm 15\text{ V}$ ,  $R_{Gon} = 2\ \Omega$ ,  $R_{Goff} = 2\ \Omega$ ,  $V_{CE} = 300\text{ V}$

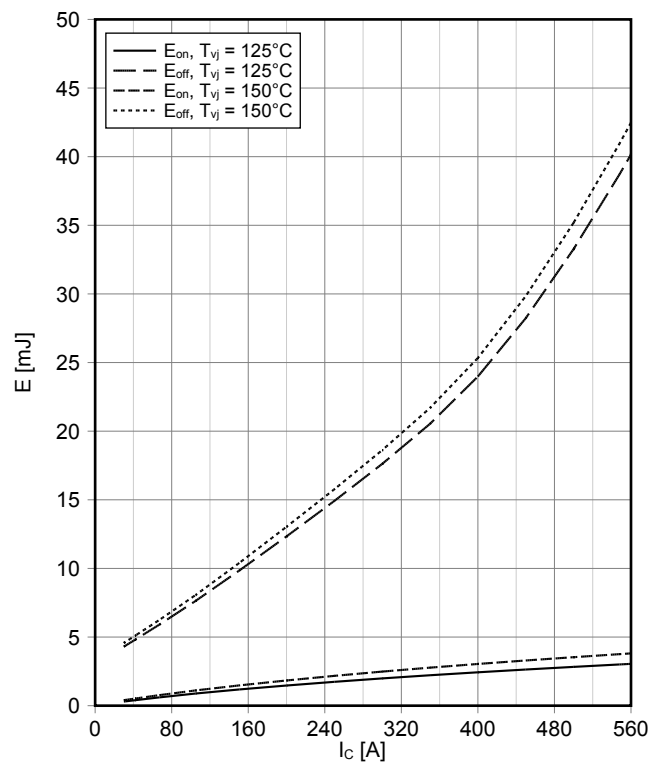

## 暫定データ Preliminary Data

### スイッチング損失 IGBT- インバータ (Typical) switching losses IGBT, Inverter (typical)

$E_{on} = f(R_G), E_{off} = f(R_G)$   
 $V_{GE} = \pm 15 \text{ V}, I_C = 280 \text{ A}, V_{CE} = 300 \text{ V}$

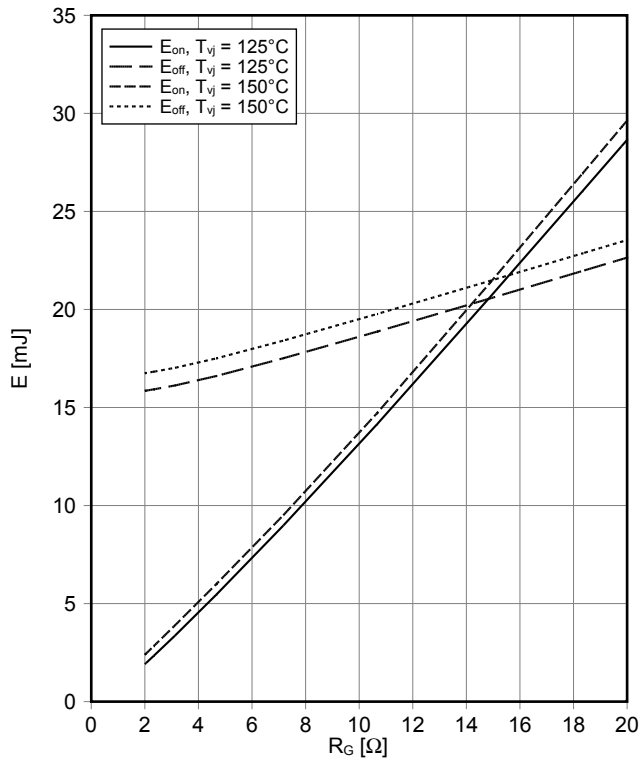

### 過渡熱インピーダンス IGBT- インバータ transient thermal impedance IGBT, Inverter

$Z_{thJH} = f(t)$

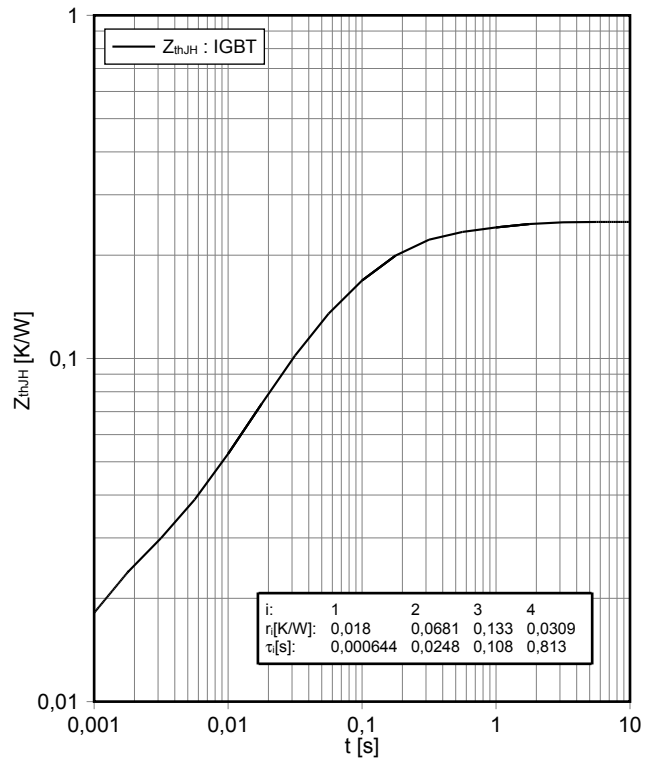

### 逆バイアス安全動作領域 IGBT- インバータ (RBSOA) reverse bias safe operating area IGBT, Inverter (RBSOA)

$I_C = f(V_{CE})$   
 $V_{GE} = \pm 15 \text{ V}, R_{Goff} = 2 \Omega, T_{vj} = 150^\circ\text{C}$

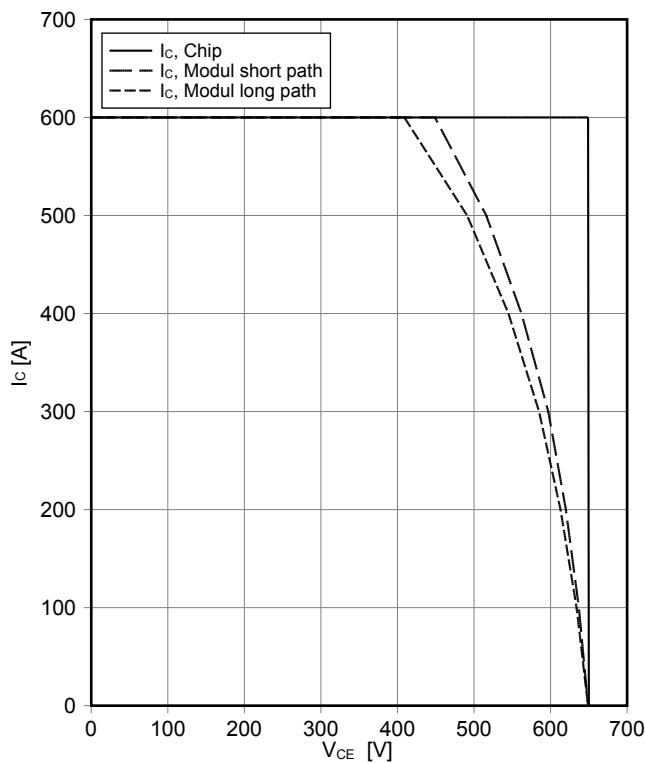

### 順電圧特性 Diode、インバータ (typical) forward characteristic of Diode, Inverter (typical)

$I_F = f(V_F)$

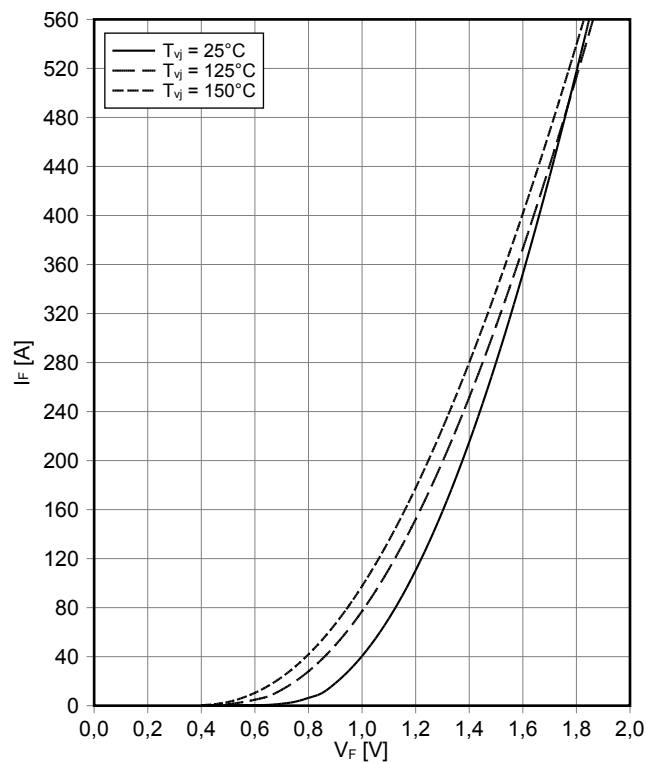

## 暫定データ Preliminary Data

### スイッチング損失 Diode、インバータ (Typical) switching losses Diode, Inverter (typical)

$E_{rec} = f(I_F)$   
 $R_{Gon} = 2 \Omega, V_{CE} = 300 V$

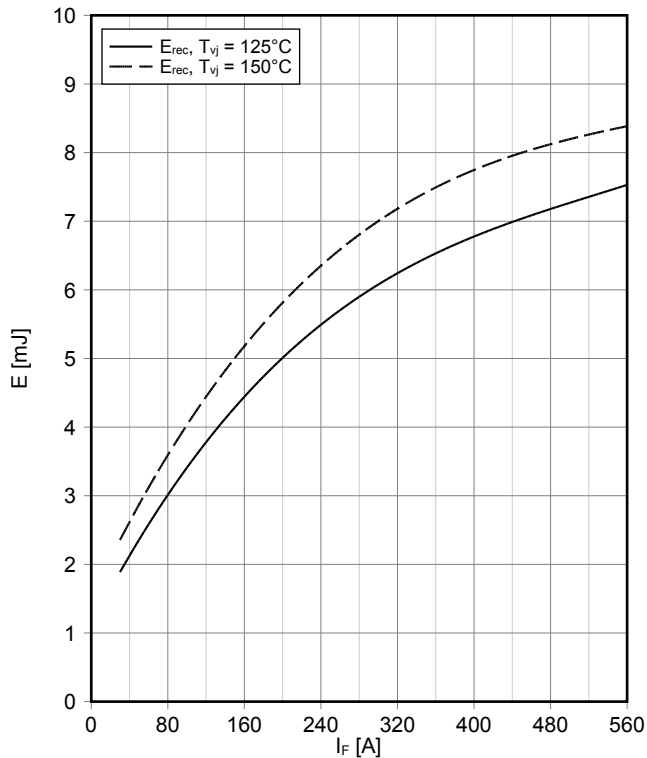

### スイッチング損失 Diode、インバータ (Typical) switching losses Diode, Inverter (typical)

$E_{rec} = f(R_G)$   
 $I_F = 280 A, V_{CE} = 300 V$

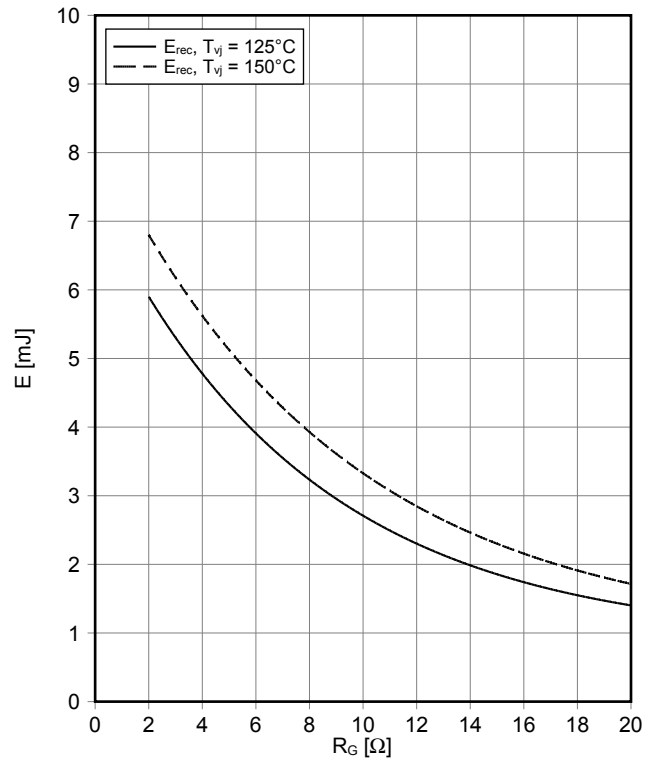

### 過渡熱インピーダンス Diode、インバータ transient thermal impedance Diode, Inverter

$Z_{thJH} = f(t)$

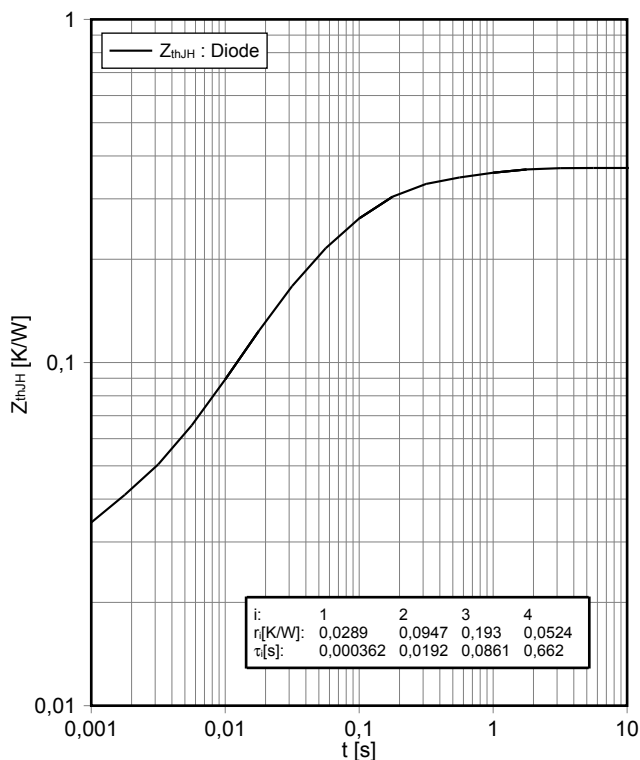

### 順電圧特性 ダイオード、スリー・レベル ( typical) forward characteristic of Diode, 3-Level ( typical)

$I_F = f(V_F)$

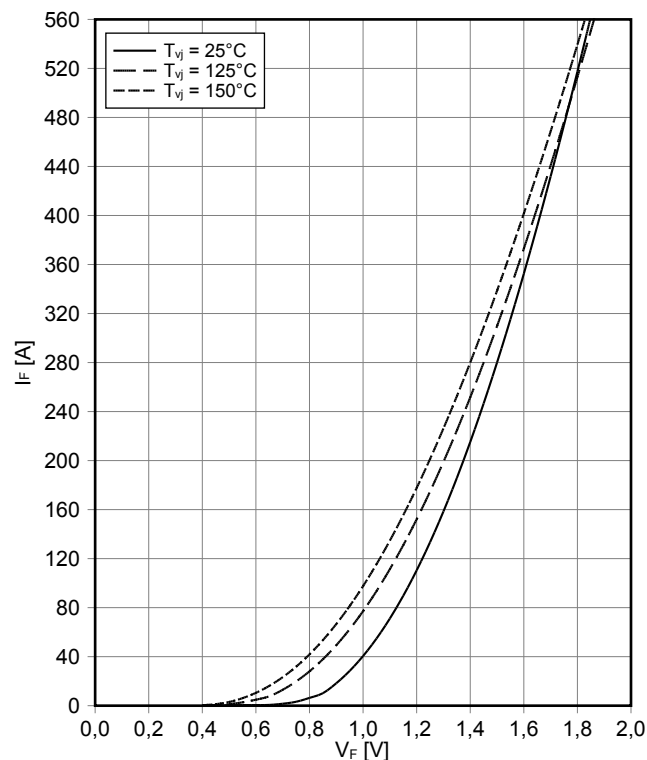

## 暫定データ Preliminary Data

過渡熱インピーダンス ダイオード、スリー・レベル  
transient thermal impedance Diode, 3-Level  
 $Z_{thJH} = f(t)$

NTC-サーミスタ サーミスタの温度特性  
NTC-Thermistor-temperature characteristic (typical)  
 $R = f(T)$

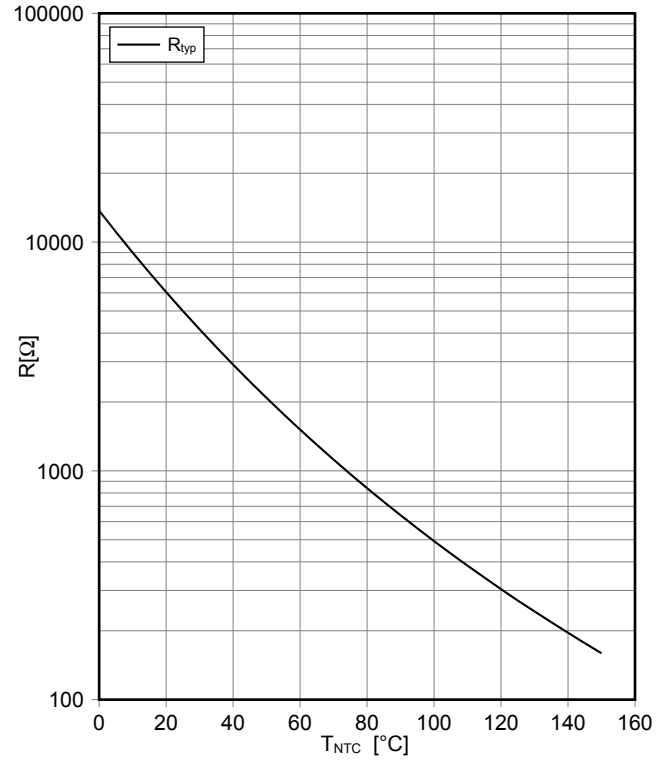
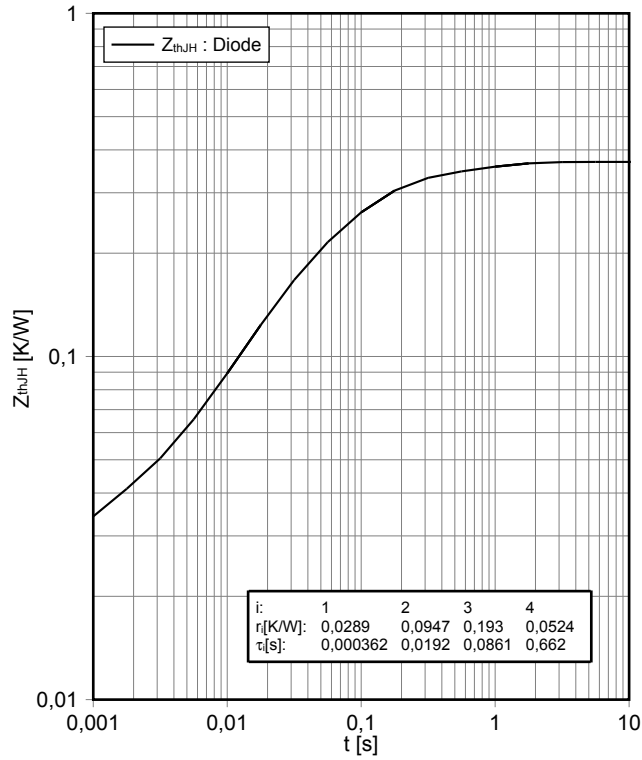

## 回路図 / Circuit diagram

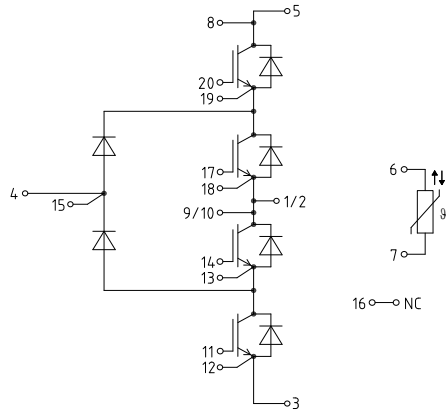

## パッケージ概要 / Package outlines

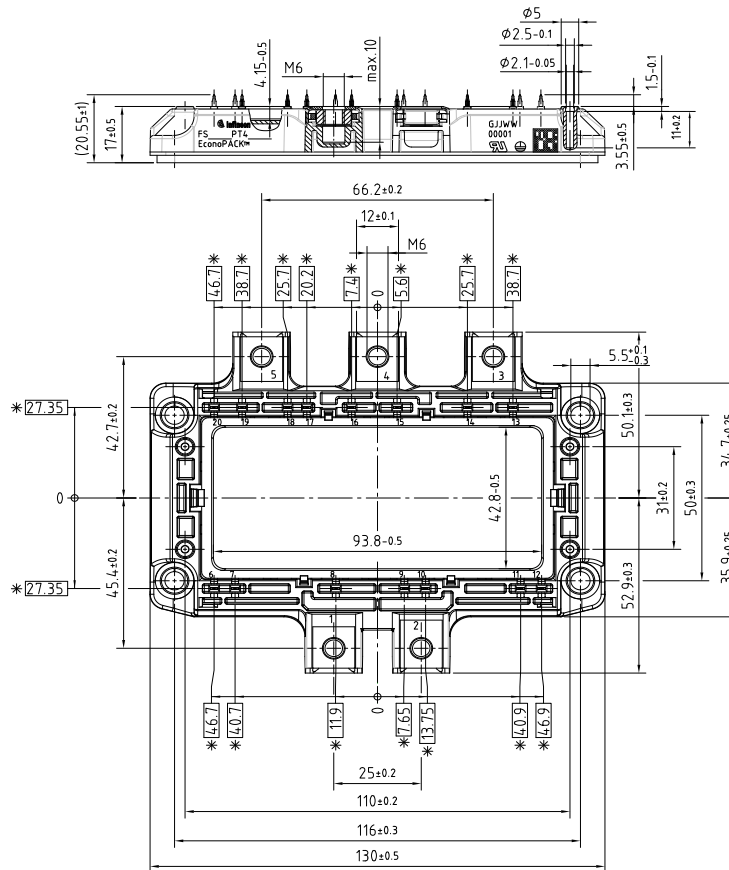

\* = alle Maße mit einer Toleranz von  $\pm 0.4$   
 \* = all dimensions with tolerance of  $\pm 0.4$

Maße im aufgeschraubtem Zustand gemessen  
 dimensions valid in mounted condition

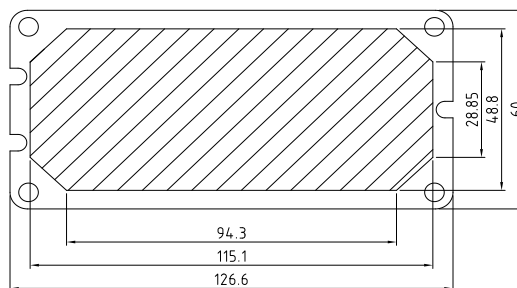

restricted area for Thermal Interface Material

## Trademarks of Infineon Technologies AG

µHVIC™, µIPM™, µPFC™, AU-ConvertIR™, AURIX™, C166™, CanPAK™, CIPOS™, CIPURSE™, CoolIDP™, CoolGaN™, COOLiR™, CoolMOS™, CoolSET™, CoolSiC™, DAVE™, DI-POL™, DirectFET™, DrBlade™, EasyPIM™, EconoBRIDGE™, EconoDUAL™, EconoPACK™, EconoPIM™, EiceDRIVER™, eupec™, FCOS™, GaNpowIR™, HEXFET™, HITFET™, HybridPACK™, iMOTION™, IRAM™, ISOFACE™, IsoPACK™, LEDrivIR™, LITIX™, MIPAQ™, ModSTACK™, my-d™, NovalithIC™, OPTIGA™, OptiMOS™, ORIGA™, PowIRaudio™, PowIRstage™, PrimePACK™, PrimeSTACK™, PROFET™, PRO-SIL™, RASIC™, REAL3™, SmartLEWIS™, SOLID FLASH™, SPOC™, StrongIRFET™, SupIRBuck™, TEMPFET™, TRENCHSTOP™, TriCore™, UHVIC™, XHP™, XMC™

Trademarks updated November 2015

## Other Trademarks

All referenced product or service names and trademarks are the property of their respective owners.

Edition 2016-10-24

Published by  
Infineon Technologies AG  
81726 München, Germany

© 2016 Infineon Technologies AG.  
All Rights Reserved.

Do you have a question about this document?  
Email: [erratum@infineon.com](mailto:erratum@infineon.com)

## 重要事項

本文書に記載された情報は、いかなる場合も、条件または特性の保証とみなされるものではありません（「品質の保証」）。本文に記載された一切の事例、手引き、もしくは一般的な価値、および / または本製品の用途に関する一切の情報に関し、インフィニオンテクノロジーズ（以下、「インフィニオン」）はここに、第三者の知的所有権の不侵害の保証を含むがこれに限らず、あらゆる種類の一切の保証および責任を否定いたします。

さらに、本文書に記載された一切の情報は、お客様の用途におけるお客様の製品およびインフィニオン製品の一切の使用に関し、本文書に記載された義務ならびに一切の関連する法的要件、規範、および基準をお客様が遵守することを条件としています。

本文書に含まれるデータは、技術的訓練を受けた従業員のみを対象としています。本製品の対象用途への適合性、およびこれら用途に関連して本文書に記載された製品情報の完全性についての評価は、お客様の技術部門の責任にて実施してください。

本製品、技術、納品条件、および価格についての詳しい情報は、インフィニオンの最寄りの営業所までお問い合わせください（[www.infineon.com](http://www.infineon.com)）。

## 警告事項

技術的要件に伴い、製品には危険物質が含まれる可能性があります。当該種別の詳細については、インフィニオンの最寄りの営業所までお問い合わせください。

インフィニオンの正式代表者が署名した書面を通じ、インフィニオンによる明示の承認が存在する場合を除き、インフィニオンの製品は、当該製品の障害またはその使用に関する一切の結果が、合理的に人的傷害を招く恐れのある一切の用途に使用することはできないこと予めご了承ください

## IMPORTANT NOTICE

The information given in this document shall in no event be regarded as a guarantee of conditions or characteristics ("Beschaffenheitsgarantie"). With respect to any examples, hints or any typical values stated herein and/or any information regarding the application of the product, Infineon Technologies hereby disclaims any and all warranties and liabilities of any kind, including without limitation warranties of non-infringement of intellectual property rights of any third party.

In addition, any information given in this document is subject to customer's compliance with its obligations stated in this document and any applicable legal requirements, norms and standards concerning customer's products and any use of the product of Infineon Technologies in customer's applications.

The data contained in this document is exclusively intended for technically trained staff. It is the responsibility of customer's technical departments to evaluate the suitability of the product for the intended application and the completeness of the product information given in this document with respect to such application.

For further information on the product, technology, delivery terms and conditions and prices please contact your nearest Infineon Technologies office ([www.infineon.com](http://www.infineon.com)).

## WARNINGS

Due to technical requirements products may contain dangerous substances. For information on the types in question please contact your nearest Infineon Technologies office.

Except as otherwise explicitly approved by Infineon Technologies in a written document signed by authorized representatives of Infineon Technologies, Infineon Technologies' products may not be used in any applications where a failure of the product or any consequences of the use thereof can reasonably be expected to result in personal injury.