MSM5299C

80-DOT LCD SEGMENT DRIVER

GENERAL DESCRIPTION

The MSM5299C is a dot matrix LCD segment driver LSI which is fabricated using CMOS low power metal gate technology. This LSI consists of an 80-bit bidirectional shift register, 80-bit latch, 80-bit level shifter, and 80-bit 4-level driver.

It receives the 4-bit parallel display data transferred from a microcomputer or an LCD controller LSI such as MSM6255, then outputs the LCD driving waveform to the LCD.

This LSI is improved with respect to timing between load and clock in the switching characteristics of MSM5299A. ($t_{LC} = 200\text{ns} \rightarrow 63\text{ns}$)

However, note that the timing regulations for the load signal leading edge are added.

FEATURES

- Logic supply voltage : 4.5 to 5.5V
- LCD driving voltage : 8 to 28V
- Applicable LCD duty : 1/64 to 1/256
- LCD Output : 80
- 4-bit parallel data processing has improved the transfer speed to 1/4 that of the conventional serial transfer, thereby achieving low power consumption
- Can be interfaced with the LCD controller LSI MSM6255
- Applicable common driver : MSM5298A (68 outputs)
- Package options :
 - 100-pin plastic QFP (QFP100-P-1420-0.65-K) (Product name : MSM5299CGS-K)
 - 100-pin plastic QFP (QFP100-P-1420-0.65-BK) (Product name : MSM5299CGS-BK)

BLOCK DIAGRAM

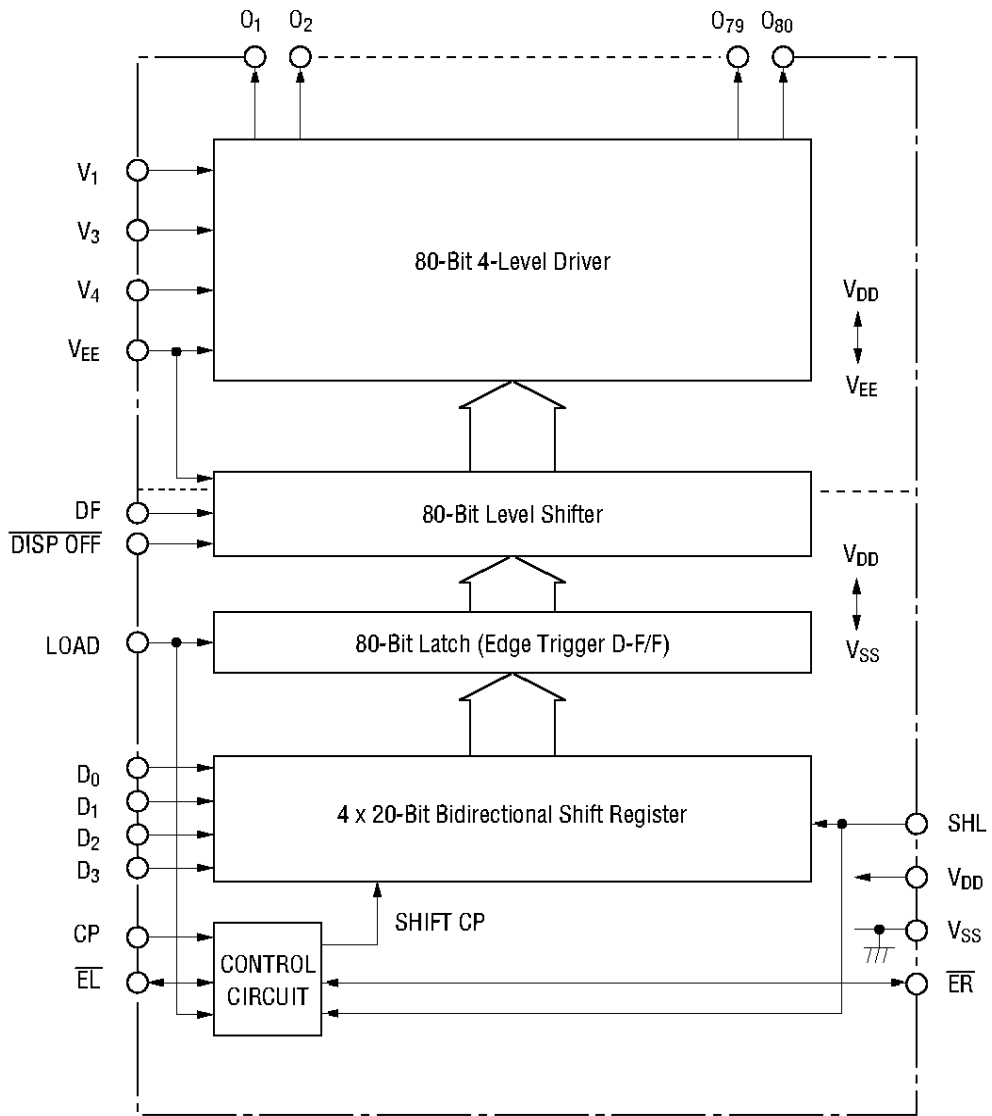

PIN CONFIGURATION (TOP VIEW)

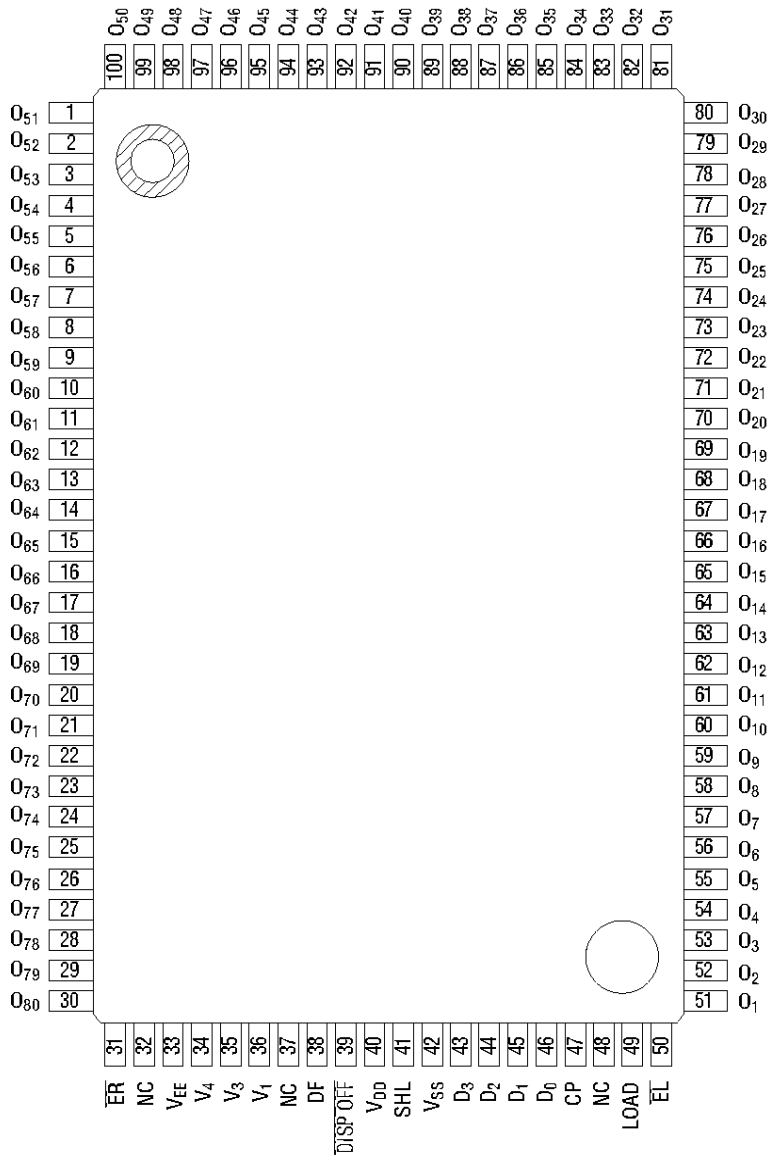

NC : No connection

100-Pin Plastic QFP

Note : The abbreviated part number "M5299C" is imprinted on the package surface.

ABSOLUTE MAXIMUM RATINGS

(V_{SS} = 0V)

Parameter	Symbol	Condition	Rating	Unit
Supply Voltage (1)	V _{DD}	T _a = 25°C	-0.3 to +6	V
Supply Voltage (2)	V _{LCD}	T _a = 25°C, V _{DD} -V _{EE} ^{*1}	0 to 30	V
Input Voltage	V _I	T _a = 25°C	-0.3 to V _{DD} +0.3	V
Storage Temperature	T _{STG}	—	-55 to +150	°C

*1 V_{DD} ≥ V₁ > V₃ > V₄ > V_{EE}

RECOMMENDED OPERATING CONDITIONS

(V_{SS} = 0V)

Parameter	Symbol	Condition	Range	Unit
Supply Voltage (1)	V _{DD}	—	4.5 to 5.5	V
Supply Voltage (2)	V _{LCD}	V _{DD} -V _{EE} ^{*1}	8 to 28	V
Operating Temperature	T _{op}	—	-20 to +85	°C

*1 V_{DD} ≥ V₁ > V₃ > V₄ > V_{EE}

ELECTRICAL CHARACTERISTICS
DC Characteristics

(V_{DD} = 5V ± 10%, Ta = -20 to +85°C)

Parameter	Symbol	Condition	Min.	Typ.	Max.	Unit
"H" Input Voltage	V _{IH} ^{*1}	—	0.8V _{DD}	—	V _{DD}	V
"L" Input Voltage	V _{IL} ^{*1}	—	V _{SS}	—	0.2V _{DD}	V
"H" Input Current	I _{IH} ^{*1}	V _{IH} = V _{DD} , V _{DD} = 5.5V	—	—	1	μA
"L" Input Current	I _{IL} ^{*1}	V _{IL} = 0V, V _{DD} = 5.5V	—	—	-1	μA
"H" Output Voltage	V _{OH} ^{*2}	I _O = -0.2mA, V _{DD} = 4.5V	V _{DD} - 0.4	—	—	V
"L" Output Voltage	V _{OL} ^{*2}	I _O = 0.2mA, V _{DD} = 4.5V	—	—	0.4	V
ON Resistance	R _{ON} ^{*4}	V _{DD} - V _{EE} = 23V V _N - V _O = 0.25V, V _{DD} = 4.5V ^{*3}	—	—	4	kΩ
Stand-by Current	I _{DDSBY}	f _{CP} = 1MHz, V _{DD} = 5.5V V _{DD} - V _{EE} = 26V, no load ^{*5}	—	—	200	μA
Supply Current (1)	I _{DD1}	f _{CP} = 1MHz, V _{DD} = 5.5V V _{DD} - V _{EE} = 26V, no load ^{*6}	—	—	3	mA
Supply Current (2)	I _V	f _{CP} = 1MHz, V _{DD} = 5.5V V _{DD} - V _{EE} = 26V, no load ^{*7}	—	—	±100	μA
Input Capacitance	C _I	f = 1MHz	—	5	—	pF

*1 Applicable to LOAD, CP, D₀ to D₃, \overline{EL} , \overline{ER} , SHL, DF, $\overline{DISP OFF}$ pins

*2 Applicable to \overline{EL} , \overline{ER} pins.

*3 V_N = V_{DD} to V_{EE}, V₄ = $\frac{13}{15}$ (V_{DD} - V_{EE}), V₃ = $\frac{2}{15}$ (V_{DD} - V_{EE}), V_{DD} = V₁

*4 Applicable to O₁ to O₈₀ pins.

*5 Display data 1010, f_{DF} = 40 Hz, current that flows from V_{DD} to V_{SS} when the display data is not clocked in.

*6 Display data 1010, f_{DF} = 40 Hz, current that flows from V_{DD} to V_{SS} when the display data is clocked in.

*7 Display data 1010, f_{DF} = 40 Hz, current that flows to each of the V₁, V₃ and V₄ pins.

Switching Characteristics

($V_{DD} = 5V \pm 10\%$, $T_a = -20$ to $+75^\circ C$, $C_L = 15pF$)

Parameter	Symbol	Condition	Min.	Typ.	Max.	Unit
Clock Frequency	f_{CP}	DUTY=50%	—	—	3.4	MHz
Clock, Load Pulse Width	t_w	—	100	—	—	ns
Clock Pulse Rise/Fall Time	t_r, t_f	—	—	—	50	ns
Data Setup Time	t_{DSU}	—	50	—	—	ns
Data Hold Time	t_{DHD}	—	80	—	—	ns
Clock → Load Time	t_{CL}	—	63	—	—	ns
Load Setup Time	t_{LSU1}	—	90	—	—	ns
Load Setup Time	t_{LSU2}	—	90	—	—	ns
Load → Clock Time	t_{LC}	—	63	—	—	ns
Propagation Delay Time	t_{PHL}	—	—	—	224	ns
$\overline{ER}, \overline{EL}$ Setup Time	t_{ESU}	—	70	—	—	ns

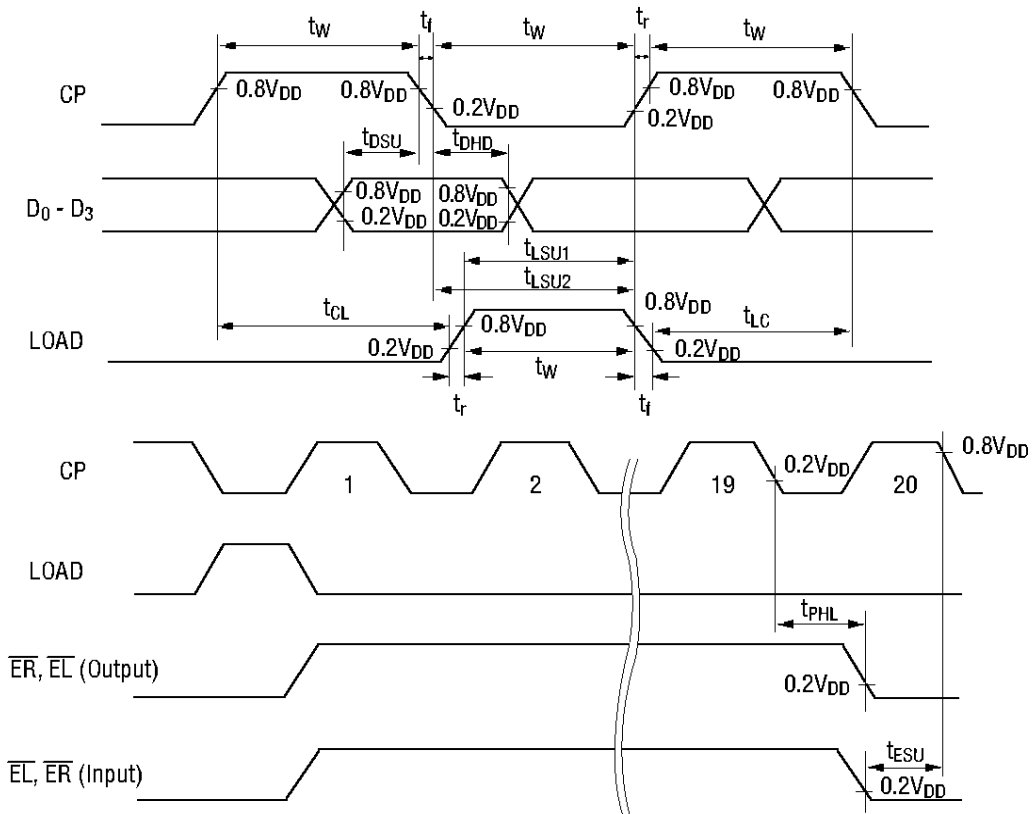

- **D₀, D₁, D₂, D₃**

Display data input pins for 4×20-bit shift register. The display data is clocked into these pins. The combinations of D₀ to D₃, DF signal level, display data output level and the display on the LCD panel are described in the table below.

D ₀ - D ₃	DF	Liquid crystal drive output	Liquid crystal display
L	L	Non-select level (V ₃)	OFF
H	L	Select level (V ₁)	ON
L	H	Non-select level (V ₄)	OFF
H	H	Select level (V _{EE})	ON

- **LOAD**

The signal for latching the shift register contents is input to this pin. The display data stored in the shift register is latched at the falling edge of the LOAD pulse.

- **DF**

Alternate signal input pin for LCD driving. Frame inversion signal is input to this pin.

- **V_{DD}, V_{SS}**

Supply voltage pins. V_{DD} should be 4.5 to 5.5V. V_{SS} is a ground pin (V_{SS} = 0V).

- **V₁, V₃, V₄, V_{EE}**

Bias supply voltage pin to drive the LCD. Bias voltage to drive the LCD is supplied from an external source.

- **O₁ to O₈₀**

Display data output pins which correspond to the respective latch contents. One of V₁, V₃, V₄ and V_{EE} is selected as a display driving voltage source based on the combination of the latched data level and DF signal. (Refer to the Truth Table).

The outputs O₁ to O₈₀ are connected to the segment side of the LCD panel.

- **DISP OFF**

Input pin for controlling the outputs of O₁ to O₈₀. V₁ level is output from O₁ to O₈₀ pins during "L" level input. Refer to the Truth Table.

Truth Table

DF	Latched data	DISP OFF	Driver output level (O ₁ -O ₈₀)
L	L	H	V ₃
L	H	H	V ₁
H	L	H	V ₄
H	H	H	V _{EE}
X	X	L	V ₁

NOTES ON USE

Note the following when turning power on and off :

The LCD drivers of this IC require a high voltage. For this reason, if a high voltage is applied to the LCD drivers with the logic power supply floating, excess current flows. This may damage the IC. Be sure to carry out the following power-on and power-off sequences :

When turning power on :

First V_{DD} ON, next V_{EE}, V₄, V₃, V₁ ON. Or both ON at the same time.

When turning power off :

First V_{EE}, V₄, V₃, V₁ OFF, next V_{DD} OFF. Or both OFF at the same time.

PACKAGE DIMENSIONS

(Unit : mm)

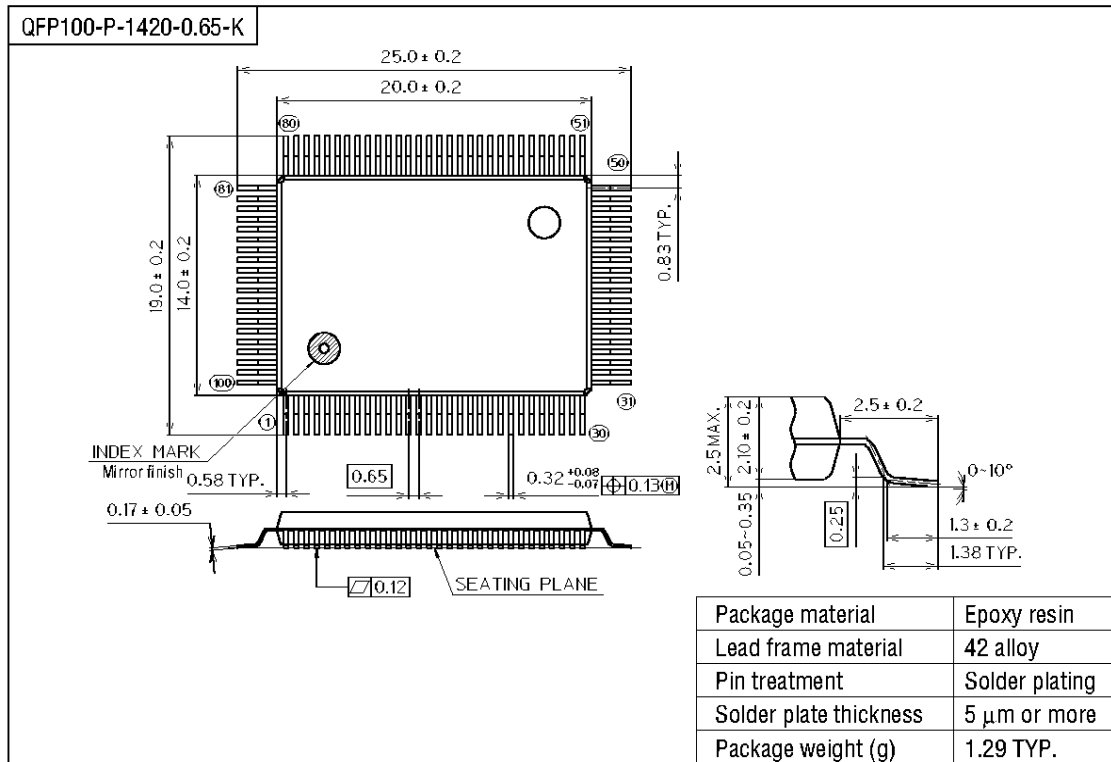

Notes for Mounting the Surface Mount Type Package

The SOP, QFP, TSOP, SOJ, QFJ (PLCC), SHP and BGA are surface mount type packages, which are very susceptible to heat in reflow mounting and humidity absorbed in storage. Therefore, before you perform reflow mounting, contact Oki's responsible sales person for the product name, package name, pin number, package code and desired mounting conditions (reflow method, temperature and times).

(Unit : mm)

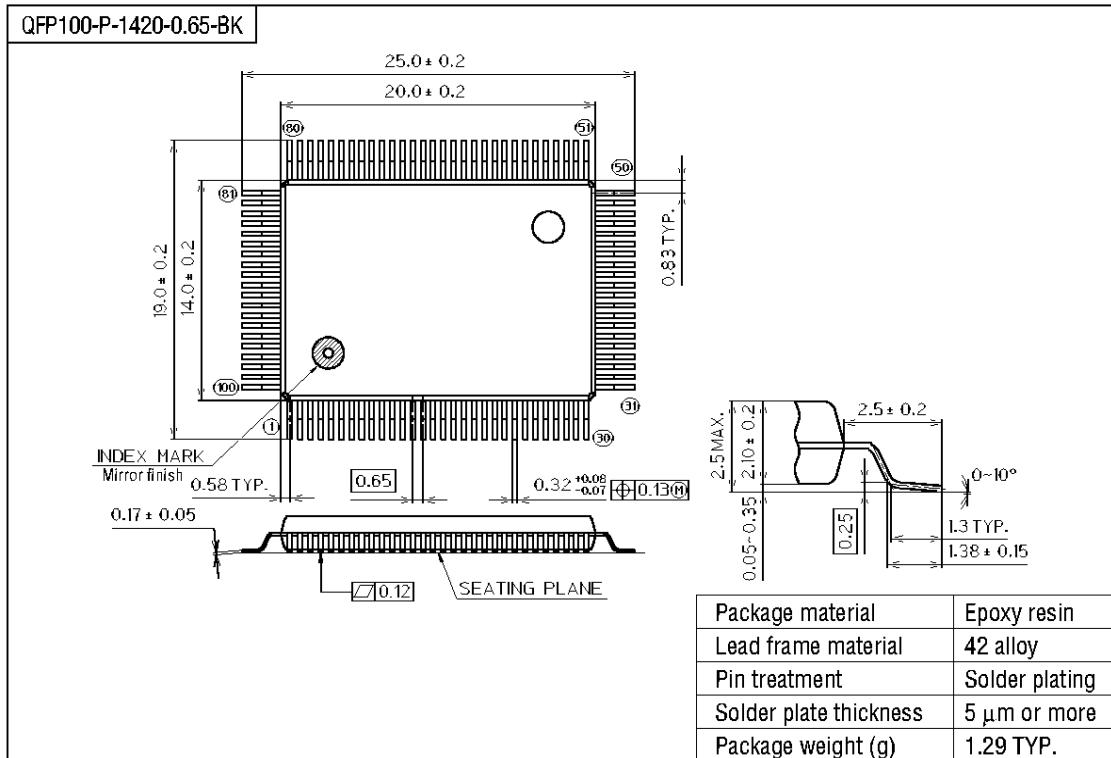

Notes for Mounting the Surface Mount Type Package

The SOP, QFP, TSOP, SOJ, QFJ (PLCC), SHP and BGA are surface mount type packages, which are very susceptible to heat in reflow mounting and humidity absorbed in storage. Therefore, before you perform reflow mounting, contact Oki's responsible sales person for the product name, package name, pin number, package code and desired mounting conditions (reflow method, temperature and times).