

DESCRIPTION

The SSI 32H6230 Servo Motor Driver is a bipolar device intended for use in Winchester disk drive head positioning systems employing linear or rotary voice coil motors. When used in conjunction with a position controller, such as the SSI 32H6220 Servo Controllers, and a position reference, such as the SSI 32H6210 Servo Demodulator, the device allows the construction of a high performance, dedicated surface head positioning system.

The SSI 32H6230 serves as a transconductance amplifier by driving 4 MOSFETs in an H-bridge configuration, performs motor current sensing and limits motor current. In its linear tracking mode, class B operation is guaranteed by crossover protection circuitry, which ensures that only one MOSFET in each leg of the H-bridge is active. The MOSFET drivers are disabled when motor velocity or current exceed externally programmable limits. In addition, automatic head retraction and spindle braking may be initiated by a low voltage condition or upon external command.

(Continued)

FEATURES

- **Predriver for linear and rotary voice coil motors**
- **Interfaces directly to MOSFET H-Bridge motor driver**
- **Class B linear mode and constant velocity retract mode**
- **FET disable function**
- **Precision differential amplifier for motor current sensing**
- **Clamp for motor current limiting**
- **Automatic head retract and spindle braking signal on power failure**
- **External digital enable**
- **Servo loop parameters programmed with external components**
- **Advanced bipolar IC requires under 240 mW from 12V supply**
- **Available in 20-pin DIP or SO packaging**

BLOCK DIAGRAM

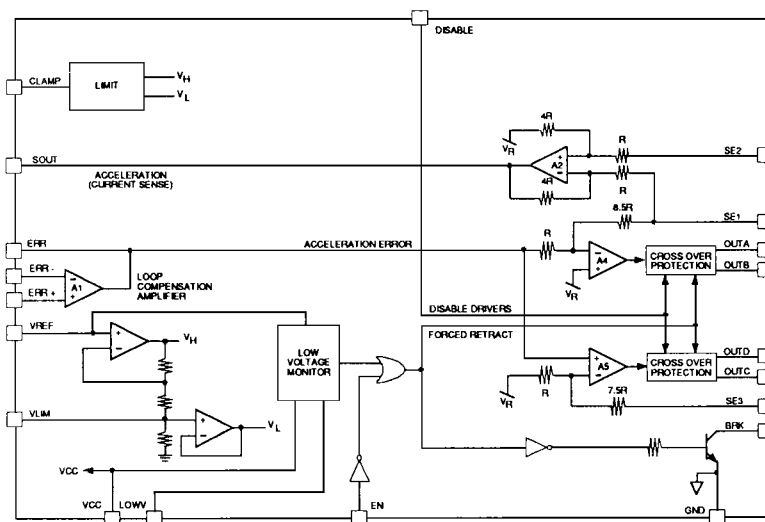

PIN DIAGRAM

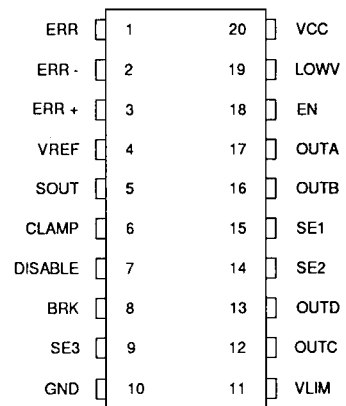

SSI 32H6230

Servo Motor Driver

DESCRIPTION (continued)

The SSI 32H6230 is implemented in an advanced bipolar process and dissipates less than 240 mW from a 12V supply. The IC is available in 20-pin DIP and 20-pin SO packaging.

FUNCTIONAL DESCRIPTION

(Refer to block diagram and typical application Fig.2)

The SSI 32H6230 has two modes of operation, linear and retract. The retract mode is activated by a power supply failure or when the control signal EN is false. Otherwise the device operates in linear mode.

During linear operation, an acceleration signal from the servo controller is applied through amplifier A1, whose three connections are all available externally. RC components may be used to provide loop compensation at this stage. The ERR signal drives two precision amplifiers, each with a gain of 8.5. The first of these amplifiers is inverting, and is formed from opamp A4, an on-chip resistor divider and an off-chip complementary MOSFET pair. The second is non-inverting, and is formed in a similar manner from opamp A5. Feedback from the MOSFET drains, on sense inputs SE1 and SE3, allows the amplifiers gains to be established precisely. The voice coil motor and a series current sense resistor are connected between SE1 and SE3.

Crossover protection circuitry between the outputs of A4 and A5, and the external MOSFETs, ensures class B operation by allowing only one MOSFET in each leg of the H-bridge to be in conduction. The crossover separation threshold, illustrated in Figure 5, is the maximum drive on any MOSFET gate when the motor voltage changes sign. The crossover circuitry can also disable all MOSFETs simultaneously (to limit motor current or velocity) or apply a constant voltage across the motor (to retract the heads at a constant velocity).

Motor current is sensed by a small resistor placed in series with the motor. The voltage drop across this resistor is amplified by a differential amplifier with a gain of 4 (A2 and associated resistors), whose inputs are SE1 and SE2. The resulting voltage, SOUT, is proportional to motor current, and hence acceleration. This signal is externally fed back to A1, so that the signal ERR represents the difference between the desired acceleration (from the servo controller) and the actual motor acceleration.

An adjustable voltage clamp is provided to prevent over current to the motor. It accomplishes the current limiting by clamping the voltage excursion at the input of A1. The voltage clamp values are programmed by VREF and VLIM. VLIM is the lower clamp value and the upper clamp limit is $2 \cdot VREF - VLIM$.

The disable function will cause all 4 bridge FETs to turn off. Note that this function does not override the retract function.

The SSI 32H6230 has low voltage monitor circuitry that will detect a loss of voltage on the VREF, VCC or LOWV pins. The power supply pin, VCC, should be connected to the disk drive's spindle motor so that its stored rotational energy may be used to hold up VCC briefly during a power failure. LOWV is used to detect a system power supply failure. When a low voltage condition is detected, the MOSFET drivers switch from linear operation to retract mode. In this mode a constant voltage is applied across the motor which will cause the heads to move at a constant speed. A mechanical stop must be provided for the heads when they reach a safe location. The current limiting circuitry will disable the MOSFET drivers when motor current increases due to loss of the velocity-induced back EMF. An open collector output, BRK, which is active while the device is in retract mode, is provided for spindle motor braking. An external RC delay may be used to defer braking until the heads are retracted.

Two examples of an entire servo path implemented with the SSI 32H6230 and its companion devices, the SSI 32H567, 32H568, and the SSI 32H6210, 32H6220 are shown in Figure 7.

SSI 32H6230 Servo Motor Driver

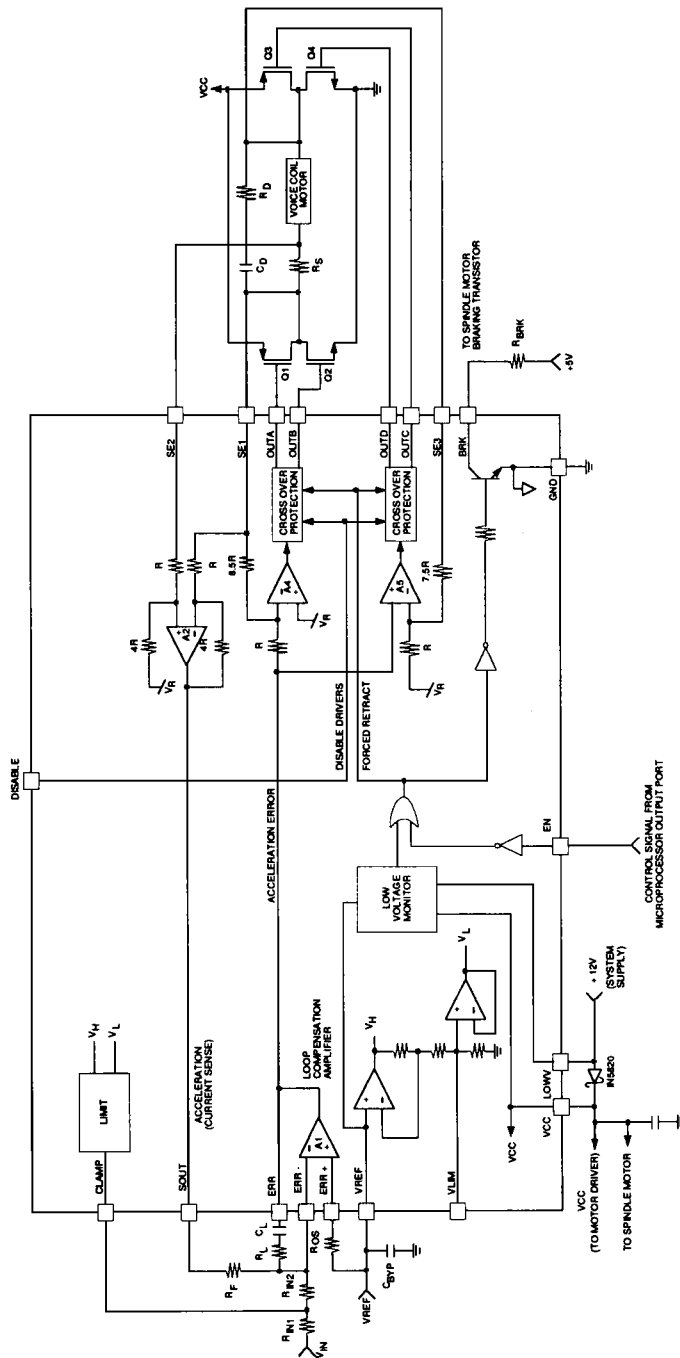

FIGURE 2: Typical Application

SSI 32H6230

Servo Motor Driver

PIN DESCRIPTION

POWER

NAME	TYPE	DESCRIPTION
VCC		POSITIVE SUPPLY - 12V power supply. Usually taken from spindle motor supply. Spindle motor stored energy permits head retraction during power failure. If VCC falls below 9V, a forced head retraction occurs.
LOWV	I	LOW VOLTAGE - System 12V supply. If this input falls below 9V, a forced head retraction occurs.
VREF	I	REFERENCE VOLTAGE - 5.4V input. All analog signals are referenced to this voltage. If VREF falls below 4.3V, a forced head retraction occurs.
GND		GROUND

CONTROL

NAME	TYPE	DESCRIPTION
ERR	O	POSITION ERROR- Loop compensation amplifier output. This signal is amplified by the MOSFET drivers and applied to the motor by an external MOSFET H-bridge, as follows: $SE3-SE1 = 17(ERR-VREF)$
ERR-	I	POSITION ERROR INVERTING INPUT - Inverting input to the loop compensation amplifier.
ERR+	I	POSITION ERROR NON-INVERTING INPUT - Non-inverting input to the loop compensation amplifier.
SOUT	O	MOTOR CURRENT SENSE OUTPUT - This output provides a voltage proportional to the voltage drop across the external current sense resistor, as follows: $SOUT-VREF=4(SE2-SE1)$
DISABLE	I	DISABLE INPUT – Active High TTL input will cause all 4 bridge FETs to turn off. DISABLE does not override the retract function.
CLAMP	I	CLAMP – A clamp pin to limit the input error voltage. The voltage swing at this pin is limited to $VREF \pm (VREF - VLIM)$.
BRK	O	BRAKE OUTPUT – Active high, open collector output which may be used to enable an external spindle motor braking transistor upon power failure or deassertion of EN.
VLIM	I	VOLTAGE LIMIT – The voltage at this pin sets the upper and lower clamp voltage limits in conjunction with the voltage at VREF. Upper Clamp Limit = $2 \cdot VREF - VLIM$ Lower Clamp Limit = VLIM.
SE2	I	MOTOR CURRENT SENSE INPUT - Non-inverting input to the current sense differential amplifier. It should be connected to one side of an external current sensing resistor in series with the motor. The inverting input of the differential amplifier is connected internally to SE1.
EN	I	ENABLE - Active high TTL compatible input enables linear tracking mode. A low level will initiate a forced head retract.

SSI 32H6230 Servo Motor Driver

FET DRIVE

NAME	TYPE	DESCRIPTION
SE3	I	MOTOR VOLTAGE SENSE INPUT - This input provides feedback to the non-inverting MOSFET driver amplifier. It is connected to one side of the motor. The gain to this point is: $SE3-VREF = 8.5(ERR-VREF)$
OUTC	O	P-FET DRIVE (NON-INVERTING) - Drive signal for a P channel MOSFET connected between one side of the motor and VCC. This MOSFET drain is connected to SE3.
OUTD	O	N-FET DRIVE (NON-INVERTING) - Drive signal for an N channel MOSFET connected between one side of the motor and GND. This MOSFET drain is connected to SE3. Crossover protection circuitry ensures that the P and N channel devices driven by OUTC and OUTD are never enabled simultaneously.
SE1	I	MOTOR VOLTAGE SENSE INPUT - This input provides feedback to the inverting MOSFET driver amplifier. It is connected to the current sensing resistor which is in series with the motor. The gain to this point is: $SE1-VREF = -8.5(ERR-VREF)$ This input is internally connected to the current sense differential amplifier inverting input.
OUTB	O	N-FET DRIVE (INVERTING) - Drive signal for an N channel MOSFET connected between the current sense resistor and GND. This MOSFET drain is also connected to SE1.
OUTA	O	P-FET DRIVE (INVERTING) - Drive signal for a P channel MOSFET connected between the current sense resistor and VCC. This MOSFET drain is also connected to SE1. Crossover protection circuitry ensures that the P and N channel devices driven by OUTC and OUTD are never enabled simultaneously.

SSI 32H6230

Servo Motor Driver

ELECTRICAL SPECIFICATIONS

ABSOLUTE MAXIMUM RATINGS

(Maximum limits indicates where permanent device damage occurs. Continuous operation at these limits is not intended and should be limited to those conditions specified in the DC operating characteristics.)

PARAMETER	CONDITIONS	MIN	TYP	MAX	UNITS
VCC		0		16	V
VREF		0		10	V
SE1, SE2, SE3, OUT D		-1.5		15	V
All other pins		-3		VCC + .3	V
Storage temperature		-45		165	°C
Solder temperature	10 sec duration			260	°C

RECOMMENDED OPERATION CONDITIONS

(Unless otherwise noted, the following conditions are valid throughout this document.)

PARAMETER	CONDITIONS	MIN	TYP	MAX	UNITS
VCC	Normal Mode	9	12	13.2	V
	Retract Mode	3.5V		14	V
VREF		5		7	V
Operating temperature		0		70	°C

DC CHARACTERISTICS

ICC, VCC current				20	mA
IREF, VREF current				2	mA

A1, LOOP COMPENSATION AMPLIFIER

Input bias current				500	nA
Input offset voltage				3	mV
Voltage swing	About VREF	2			V
Common mode range	About VREF	±1			V
Load resistance	To VREF	4			kΩ
Load capacitance				100	pF
Gain		80			dB
Unity gain bandwidth		1			MHz
CMRR	$f < 20$ kHz	60			dB
PSRR	$f < 20$ kHz	60			dB

SSI 32H6230 Servo Motor Driver

A2, CURRENT SENSE AMPLIFIER

PARAMETER	CONDITIONS	MIN	TYP	MAX	UNITS
Input impedance	SE1 to SE2	3.5	5		k Ω
Input offset voltage				2	mV
Output voltage swing		VREF-4		VCC-1.2	V
Common mode range		0		VCC-0.2	V
Load Resistance	To VREF	4			k Ω
Load Capacitance				100	pF
Output impedance	$f < 40$ kHz			20	Ω
Gain (SOUT-VREF)/(SE1-SE2)	VSE2 = VREF	3.9	4	4.1	V/V
Unity gain bandwidth		1			MHz
CMRR	$f < 20$ kHz	52			dB
PSRR	$f < 20$ kHz	60			dB

VOLTAGE CLAMP

CLAMP bias current	CLAMP = VREF			0.1	μ A
Upper CLAMP limit (VREF + 1/3 VREF)	ICLAMP = 10 μ A VLIM open		$\frac{4}{3}$ VREF		V
Lower CLAMP limit (VREF - 1/3 VREF)	ICLAMP = -10 μ A VLIM open		$\frac{2}{3}$ VREF		V
CLAMP accuracy	ICLAMP = 10 μ A	-3		3	%
CLAMP Impedance	1.0 mA > ICLAMP > 10 μ A			20	Ω
VLIM Voltage			$\frac{2}{3}$ VREF		V
VLIM Accuracy		-1		+1	%

POWER SUPPLY MONITOR

VCC fail threshold		8.5	9	9.8	V
LOWV fail threshold	Lowv < 0.5 mA	8.5	9	9.8	V
VREF fail threshold		3.9	4.3	4.8	V
Hysteresis (LOWV, VCC)			250		mV
Hysteresis (VREF)			110		mV
EN input low voltage	IL < 0.5 mA	0.8			V
EN input high voltage	IH < 40 μ A			2	V
BRK voltage	normal mode, OL < 1 mA			0.4	V
BRK leakage current	retract mode			10	μ A
BRK delay (from power fail or EN false to BRK floating)				1	ms

SSI 32H6230

Servo Motor Driver

ELECTRICAL SPECIFICATIONS (continued)

MOSFET DRIVERS

PARAMETER	CONDITIONS	MIN	TYP	MAX	UNITS
SE3 Input impedance	To VREF	10	25		k Ω
OUTA, OUTC voltage swing $ I_o < 1$ mA		0.7		VCC-1	V
OUTB, OUTD voltage swing $ I_o < 1$ mA		1		VCC-1	V
VTH, Crossover separation threshold				2	V
Slew rate (OUTA, OUTB, OUTC, OUTD)	$C_l < 1000$ pF	1.4			V/ μ s
Crossover time	300 mV step at ERR			5	μ s
Output impedance (OUTA,B,C,D)			50		k Ω
Transconductance $I(\text{OUTA,B,C,D})/(\text{ERR-VREF})$			8		mA/V
Gain $-(\text{SE1-VREF})/(\text{ERR-VREF})$ or $(\text{SE3-VREF})/(\text{ERR-VREF})$		8	8.5	9	V/V
Offset current	$R_s = 0.2\Omega$, $R_f = R_{IN}$, $V_{IN} = V_{REF}$			20	mA
Retract motor voltage (SE1-SE3)		0.7	1	1.3	V

APPLICATIONS INFORMATION

A typical SSI 32H6230 application is shown in Figure 2. The selection criteria for the external components shown are discussed below. Figure 3 shows the equivalent circuit and equations for the DC motor used in the following derivations. While the nomenclature chosen is for a rotating motor, the results are equally applicable to linear motors.

MOTOR CURRENT SENSE AND LIMITING

The series resistor which senses motor current, R_s , is chosen to be small compared to the resistance of the motor, R_m . A value of $R_s = 0.2\Omega$ is typical in disk drive applications.

VLIM, RIN1, and RIN2 must be chosen to keep the motor current below I_{max} . The voltage clamp values programmed by VREF and VLIM must be chosen to cause limiting when the motor current reaches its maximum permissible current in amps, this value may be chosen as follows:

$$|I_{max}| = \frac{CLAMP}{RIN2} \cdot \frac{RF}{4 \cdot Rs}$$

Where the upper clamp limit is $2 \cdot VREF - VLIM$ and the lower clamp limit is VLIM. If VLIM is left open, a value of $0.667 \cdot VREF$ will appear. The upper clamp limit is then $1.33 \cdot VREF$ and the lower clamp limit is $0.667 \cdot VREF$. The values of RIN1, RIN2 must be chosen to satisfy the maximum swing of V_{in} before limiting occurs,

$$V_{in(max)} = CLAMP \left(1 + \frac{RIN1}{RIN2} \right) - \frac{RIN1}{RIN2} (VREF) + VREF$$

and they should also satisfy the maximum current VCLAMP can source or sink

$$\frac{V_{in(max)} [Actual] - CLAMP}{RIN1} \leq 1mA$$

LOOP COMPENSATION

The transfer function of the SSI 32H6230 in the application of Figure 2 is shown in Figure 4(a). If the zero due to R_L and C_L in the loop compensation circuit is chosen to cancel the pole due to the motor inductance, L_m , then the transfer function can be simplified as shown in Figure 4(b), under the assumption that this pole and the pole due to the motor mechanical response are widely separated. C_L may then be chosen to set the desired open loop unity gain bandwidth.

$$C_L = \frac{68 \cdot R_s}{2 \cdot \pi \cdot R_F \cdot (R_m + R_s) \cdot BW} \quad \text{where BW is the unity gain open loop bandwidth}$$

$$R_L = \frac{L_m}{C_L \cdot (R_m + R_s)}$$

The closed loop response of the servo driver and motor combination, using the component values and simplifying assumptions given above, is given by:

$$\frac{i_m}{V_{in}}(s) = -\frac{1}{R_{in}} \cdot \frac{R_F}{4 \cdot R_s} \cdot \frac{1}{\left(1 + \frac{s}{2 \cdot \pi \cdot BW} \right)}$$

Where: $R_{in} = RIN1 + RIN2$

(This analysis neglects the pole due to the output impedance of the MOSFET drivers and the MOSFET gate capacitance, an effect that may be significant in some systems.)

R_F is chosen to be sufficiently large to avoid overloading A2 ($R_F > 4 \text{ k}\Omega$). The input resistor, R_{in} , sets the conversion factor from servo controller output voltage to servo motor current. R_{in} is chosen such that the servo controller internal voltages are scaled conveniently. The resistor R_{os} is optional and cancels out the effect of the input bias current of A1.

$$R_{os} = R_{in} // R_F$$

The external components R_D and C_D have no effect on the motor dynamics, but may be used to improve the stability of the MOSFET drivers. The load represented by the motor, Z_M , is given by:

$$Z_M = (R_s + R_m) \left(1 + s \frac{L_m}{R_s + R_m} \right) \left(1 + \frac{K_m^2}{s \cdot J\theta \cdot (R_s + R_m)} \right) (\Omega)$$

At frequencies above $(R_s + R_m) / (2\pi \cdot L_m)$ Hz, this load becomes entirely inductive, which is undesirable. R_D and C_D may be used to add some parallel resistive loading at these frequencies.

SSI 32H6230

Servo Motor Driver

APPLICATIONS INFORMATION (continud)

H-BRIDGE MOSFETS

The MOSFETs chosen for the H-bridge should have gate capacitances in the range of 500-1000 pF. The MOSFET input capacitance forms part of the compensation for the MOSFET drivers, so values below 500 pF may cause some driver instability. Excessive input capacitance will degrade the slew mode performance of the drivers.

When the motor voltage is changing polarity, the crossover protection circuits at outputs OUTA-OUTD ensure that the maximum MOSFET gate drive is less than 2V (the crossover separation threshold), as illustrated in Figure 5. The thresholds of the MOSFET devices chosen should be as large as possible to minimize conduction in this region. If the device thresholds are significantly less than the crossover separation threshold, the N and P channel devices in each leg of the H-bridge will conduct simultaneously, causing unnecessary power dissipation.

POWER FAILURE OPERATION

The power supply for the SSI 32H6230, VCC, should be taken from the system 12V supply through a schottky diode (maximum 0.5V drop at $I_f = 3A$) and connected to the disk drive spindle motor. If the system power fails, the IC will continue to operate as the spindle motor becomes a generator. The SSI 32H6230 will detect the power failure and cause a forced head retract, continuing to operate with VCC as low as 3.5V. The power fail mode will commence if either VCC or LOWV falls below 9V, or VREF falls below 4.3V, or EN is false. Hysteresis on the low voltage thresholds prevents the device from oscillating between operating modes when the power supply is marginal.

The BRK output, which is pulled low during normal operation, floats during a power failure. This allows an external transistor to be enabled for spindle motor braking. An external RC delay may be added to defer braking until head retraction is complete, since the spindle motor is required to generate the supply voltage during retraction.

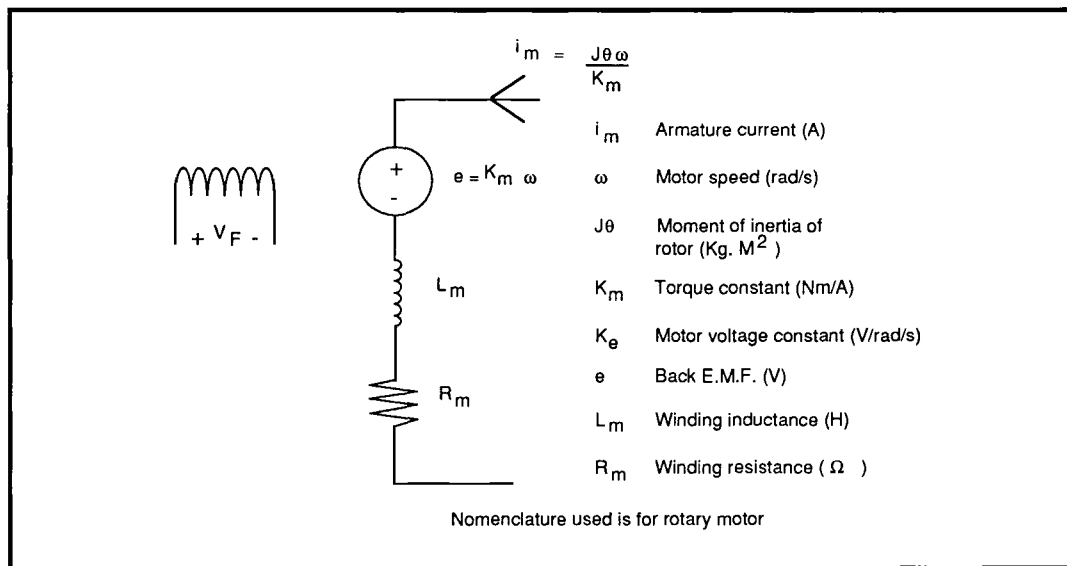

FIGURE 3: Equivalent Circuit for Fixed Field DC Motor

SSI 32H6230 Servo Motor Driver

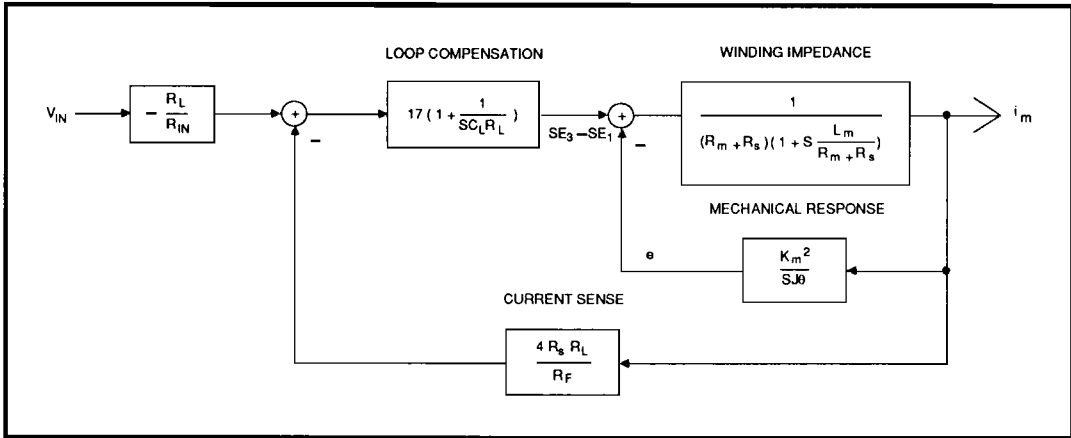

FIGURE 4A: Transfer Function of SSI 32H6230 in Typical Application with Fixed Field DC Motor

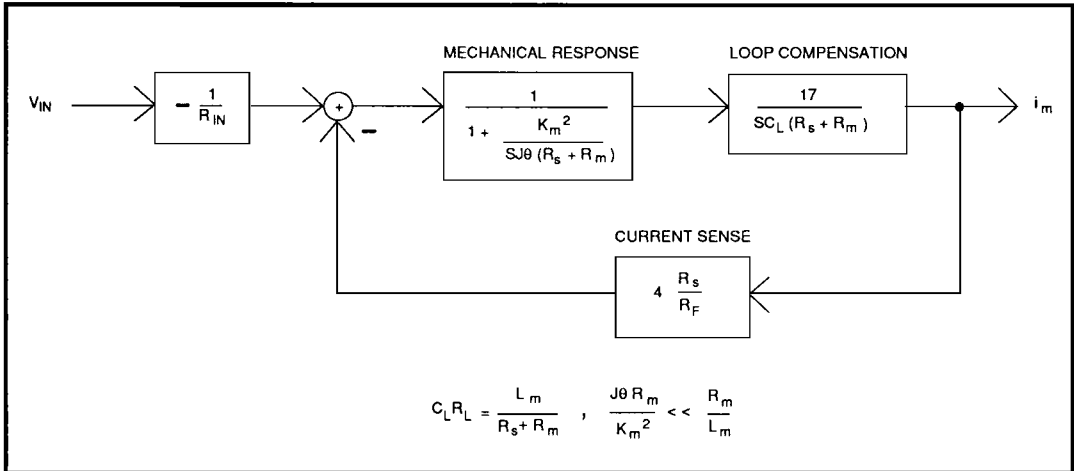

FIGURE 4B: Simplified Transfer Function of SSI 32H6230 in DC Motor Application

SSI 32H6230 Servo Motor Driver

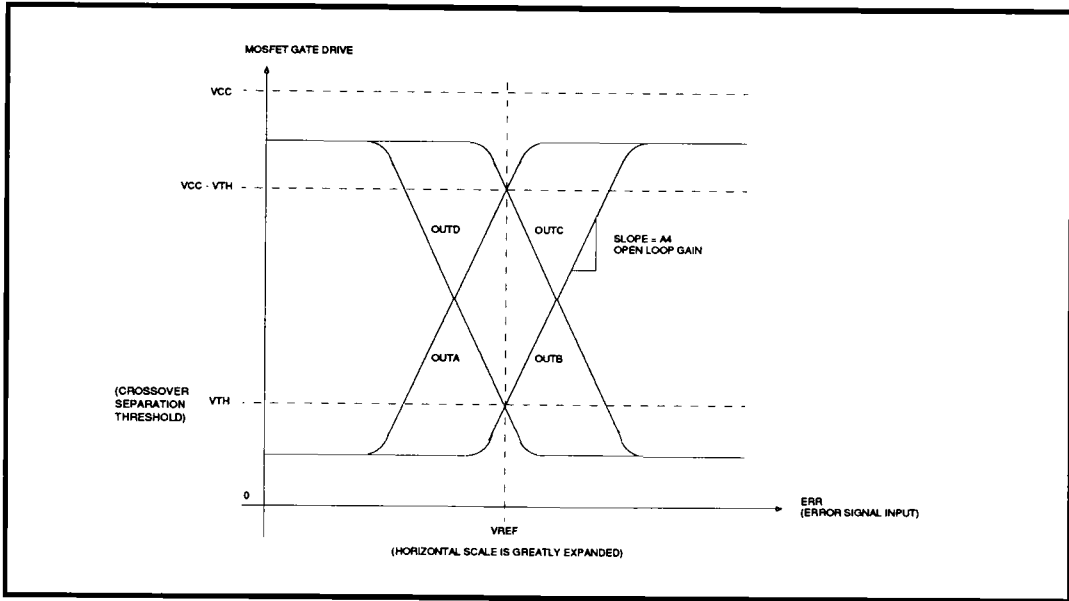

FIGURE 5: Crossover Protection

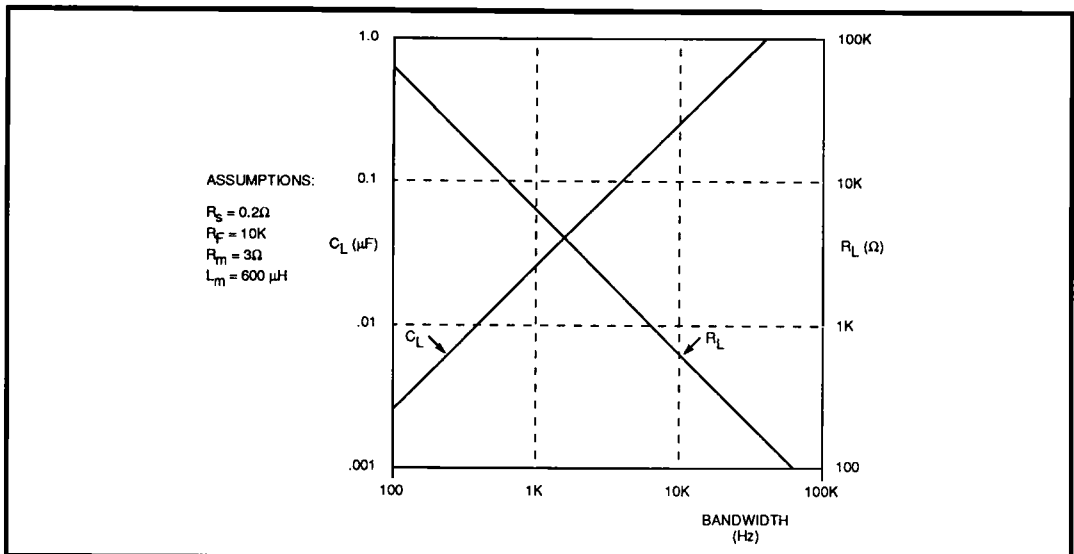

FIGURE 6: Typical Motor Driver Compensation

SSI 32H6230 Servo Motor Driver

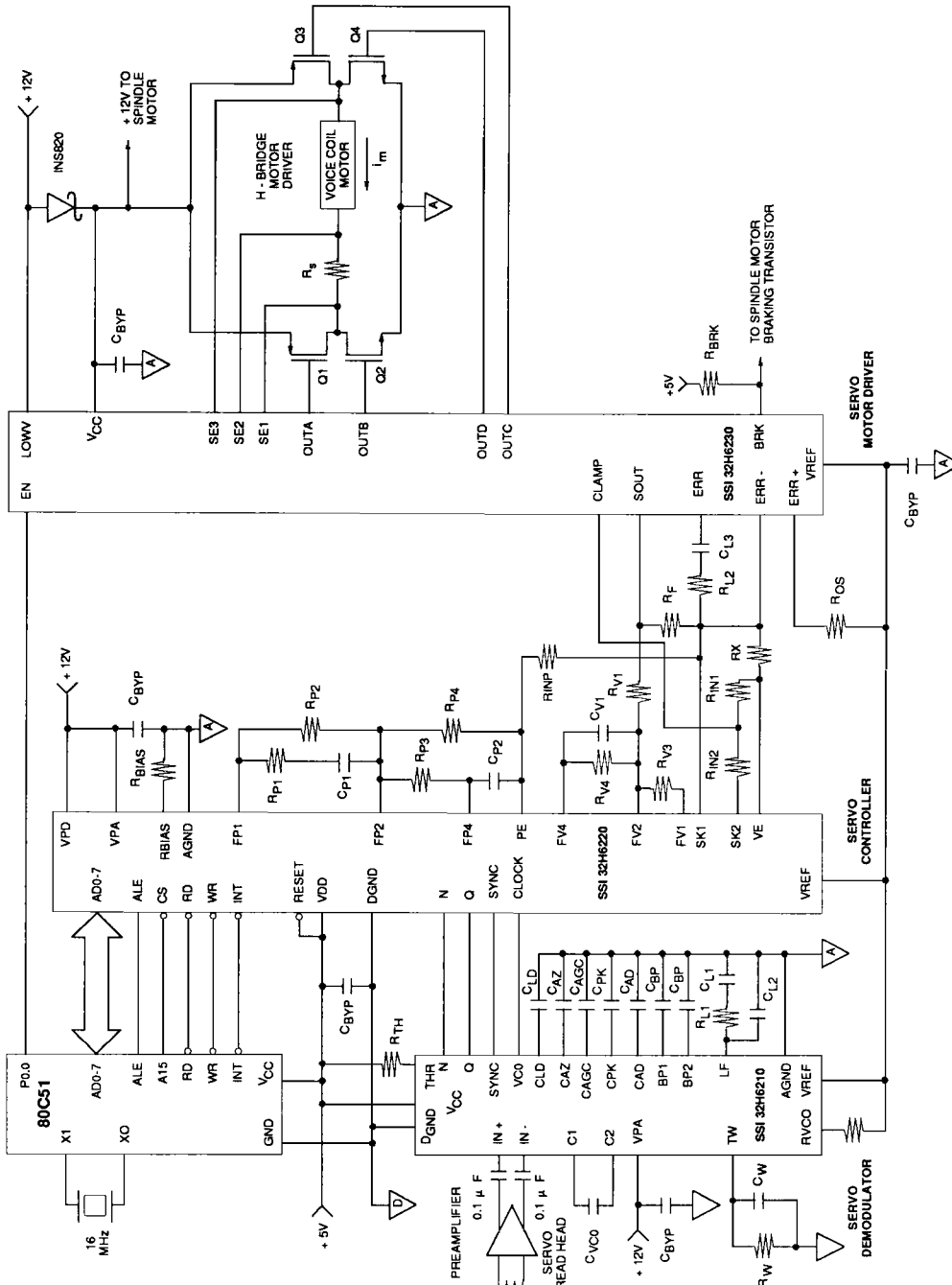

FIGURE 7: Complete Example of Servo Path Electronics Using the SSI 32H6210/6220/6230 Chip Set

SSI 32H6230

Servo Motor Driver

PACKAGE PIN DESIGNATIONS

(Top View)

CAUTION: Use handling procedures necessary for a static sensitive component.

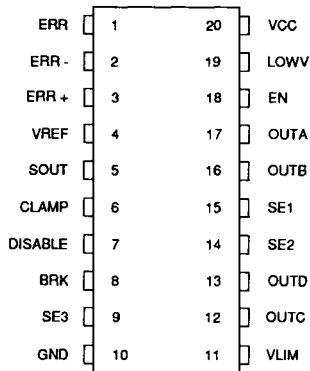

20-Pin DIP, SO

ORDERING INFORMATION

PART DESCRIPTION	ORDER NO.	PKG. MARK
SSI 32H6230, Servo Motor Driver		
20-Pin DIP	32H6230-CP	32H6230-CP
20-Lead SOL	32H6230-CL	32H6230-CL

No responsibility is assumed by Silicon Systems for use of this product nor for any infringements of patents and trademarks or other rights of third parties resulting from its use. No license is granted under any patents, patent rights or trademarks of Silicon Systems. Silicon Systems reserves the right to make changes in specifications at any time without notice. Accordingly, the reader is cautioned to verify that the data sheet is current before placing orders.

Silicon Systems, Inc., 14351 Myford Road, Tustin, CA 92680-7022 (714) 573-6000, FAX (714) 573-6914