

NUMBER  
C-440292

3RD ANGLE PROJECTION

METRIC

THIS INFORMATION IS CONFIDENTIAL AND IS DISCLOSED TO YOU ON CONDITION THAT NO FURTHER DISCLOSURE IS MADE BY YOU TO OTHER THAN AMP PERSONNEL WITHOUT WRITTEN AUTHORIZATION FROM AMP (TAIWAN) LTD.

PRINT DIST  
DW

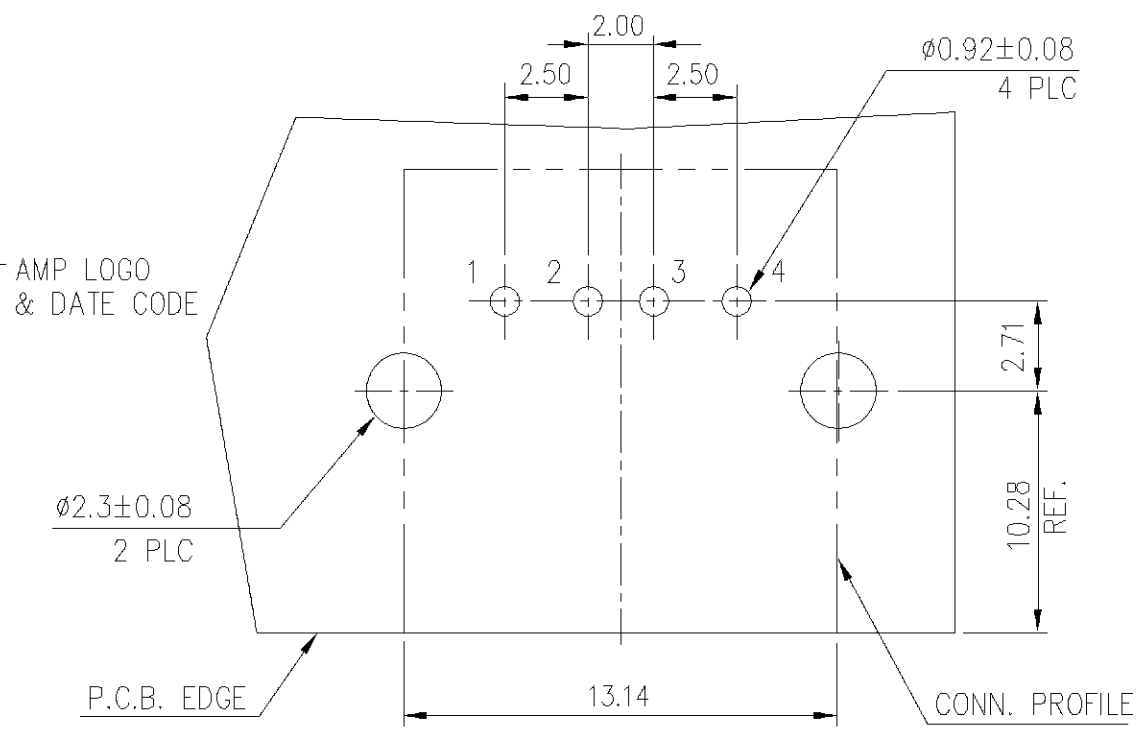
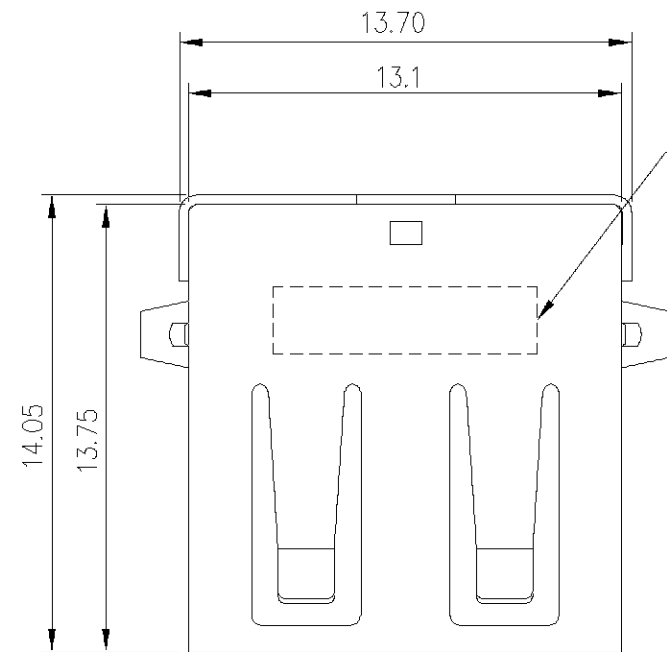

RECOMMEND P.C.B LAYOUT (THICKNESS=1.6mm)  
(TOP VIEW)

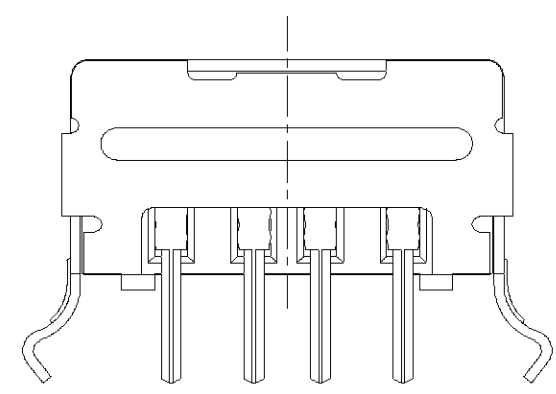
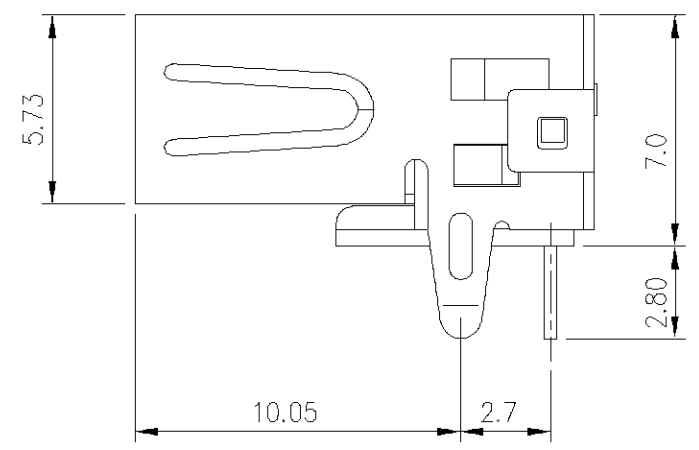
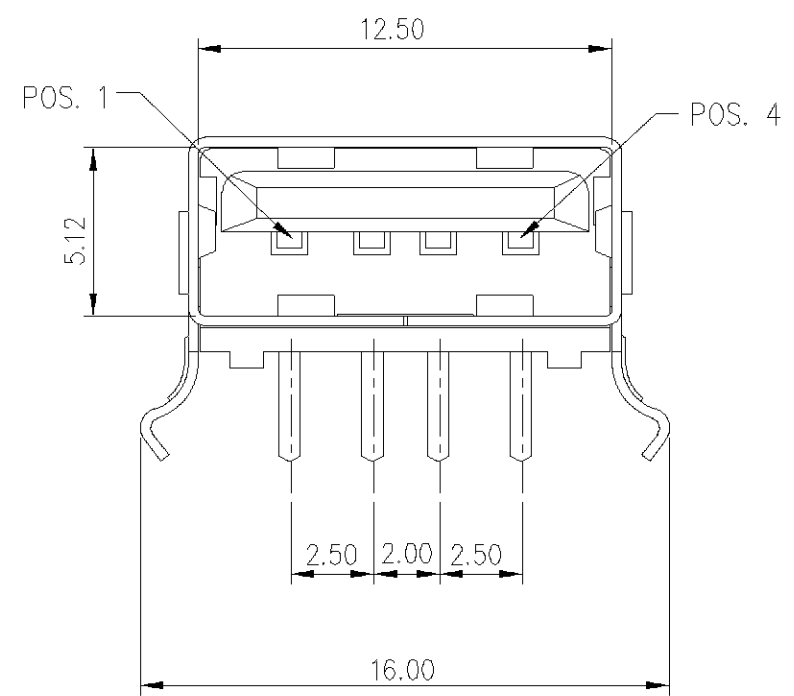

NOTE:

- MATERIAL:  
HOUSING: THERMOPLASTIC UL 94V-0, COLOR: SEE TABLE  
CONTACT: COPPER ALLOY.  
SHELL: COPPER ALLOY.  
BACK COVER: STEEL.
- FINISH:  
CONTACTS: GOLD FLASH IN CONTACT AREA, TIN-LEAD PLATING ON SOLDER TAILS, NICKEL UNDERPLATING OVERALL.  
SHELL:  $\Delta$  BRIGHT NICKEL PLATED  
 $\Delta$  MATTE TIN/LEAD PLATED  
BACK COVER: NICKEL PLATED.
- SPECIFICATIONS:  
ELECTRICAL:  
INSULATION RESISTANCE: 1000 MEGAOHMS MIN.  
CONTACT RESISTANCE: 30 MILLIOHMS MAX.  
DIELECTRIC WITHSTANDING VOLTAGE: 750 VAC  
MECHANICAL:  
MATING FORCE: 3.57KG MAX.  
UNMATING FORCE: 1.02KG MIN.

$\Delta$	MOON GRAY #3	440292-2
$\Delta$	NONMETALLIC PEARL	440292-1
SHELL PLATING	HSG COLOR	PART NUMBER

TOLERANCES UNLESS OTHERWISE SPECIFIED: 0 PLC $\pm$ 1 PLC $\pm 0.35$ 2 PLC $\pm 0.25$ 3 PLC $\pm$ ANGLES $\pm 3'$	DWN S. HOU 29-AUG-2003 CHK J. CHENG 29-AUG-2003	<b>tyco</b> <b>Electronics</b> TYCO HOLDINGS (BERMUDA) VII LTD. TAIWAN BRANCH NAME USB CON, RECP, ASS'Y, R/A 4 POS, THRU-HOLE, A TYPE
MATERIAL SEE NOTE	APVD J. WU 29-AUG-2003 PRODUCT SPEC 108-57073	
FINISH SEE NOTE	APPLICATION SPEC - WEIGHT	LOC DW A3 SCALE --
		DRAWING NO C-440292 SHEET 1 OF 2

A	ADDED P/N:-2	FZ00-0184-03	SH JC	29AUG 2003
O	FIRST RELEASED	FW00-0036-01	OH JC	10APR 2001
LTR	REVISION RECORD	ECN	DWN CHK	DATE

NUMBER  
C-440292

3RD ANGLE PROJECTION

METRIC

THIS INFORMATION IS CONFIDENTIAL AND IS DISCLOSED TO YOU ON CONDITION THAT NO FURTHER DISCLOSURE IS MADE BY YOU TO OTHER THAN AMP PERSONNEL WITHOUT WRITTEN AUTHORIZATION FROM AMP (TAIWAN) LTD. DO NOT SCALE PRINT.

PRINT DIST  
DW

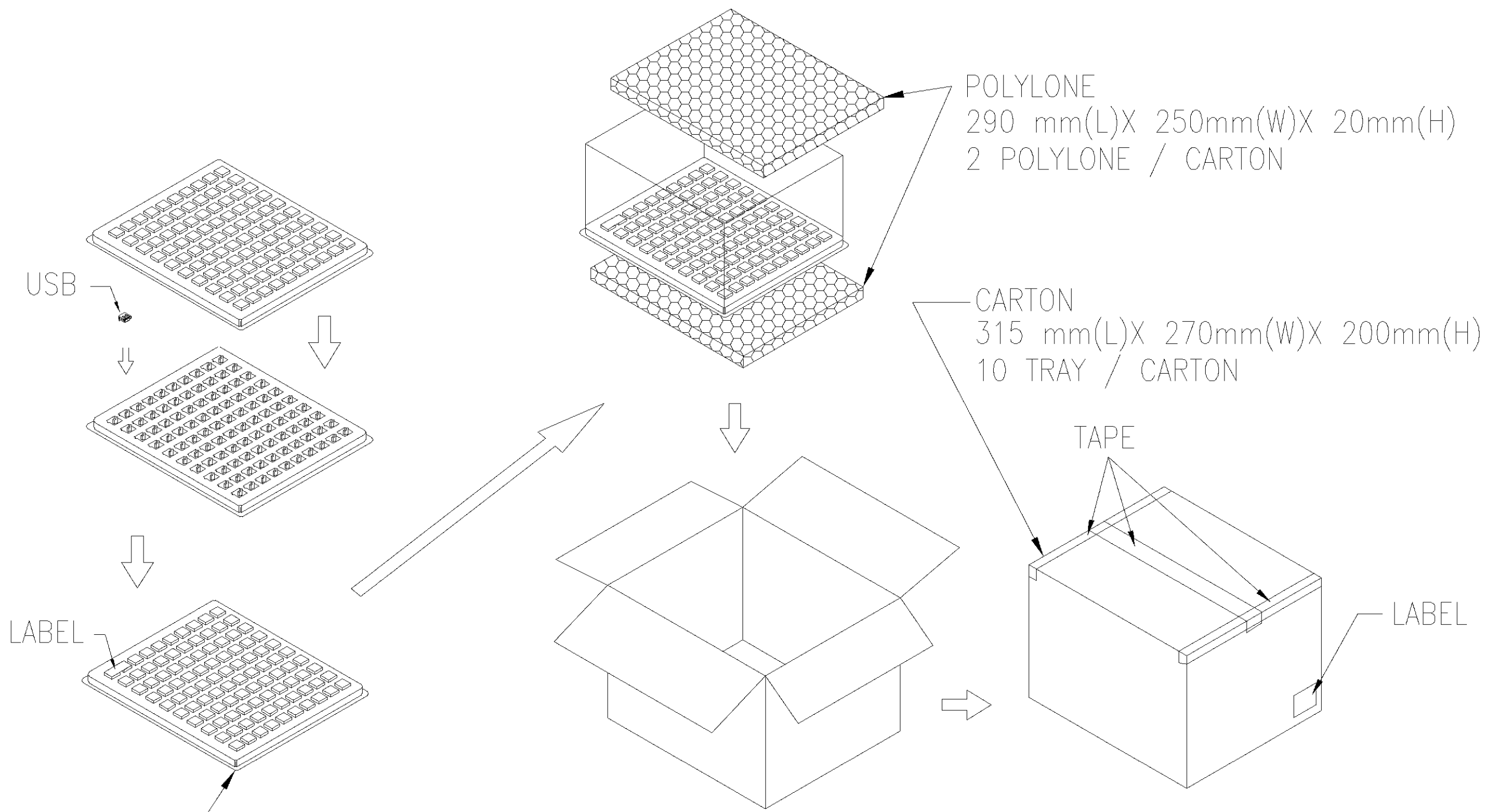

D  
C  
B  
A

8 7 6 5 4 3 2 1  
CUSTOMER DRAWING

	SEE SHEET 1			
LTR	REVISION RECORD	ECN	DWN CHK	DATE

TOLERANCES UNLESS OTHERWISE SPECIFIED: 0 PLC ± 1 PLC ±0.35 2 PLC ±0.25 3 PLC ± ANGLES ±3'		DWN S. HOU 29-AUG-2003	<b>tyco</b> TYCO HOLDINGS (BERMUDA) <b>Electronics</b> VII LTD. TAIWAN BRANCH	
MATERIAL SEE NOTE		CHK J. CHENG 29-AUG-2003	NAME USB CON, RECP, ASS'Y, R/A 4 POS, THRU-HOLE, A TYPE	
FINISH SEE NOTE		APVD J. WU 29-AUG-2003	LOC DW	SIZE A <sub>3</sub>
		PRODUCT SPEC -	DRAWING NO C-440292	REV A
		APPLICATION SPEC -	SCALE --	SHEET 2 OF 2
		WEIGHT		