

SCA.1, SCA. 2 INTERFACE CONNECTOR

240 SERIES (SCA)

■ FEATURES

- Half pitch connector conformed to SCA system (80 pins).
- Add mating guide and ESD protection to do plug-in safety and reliability (They are newly added on SCA. 2CN).
- Hot-plugging. Ground contacts mate first before other contacts mate when engagement is done (conforms to SCA.2 specification).
- To prevent pin-bending, bellows contacts are used.
- Plug: 2 types are available.
 - 1) The center of a SMT plug mates the center of a PCB.
 - 2) 0.9 mm (0.035 in.) off-set from center

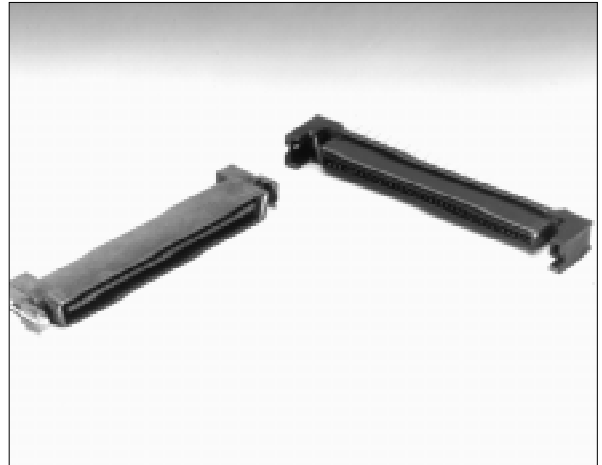

■ SPECIFICATIONS

Item	Specifications
Operating temperature range	-55°C to +105°C
Current rating	DC 1 A
Voltage rating	AC 240 V
Contact resistance	40 mΩ max. (DC 6 V, 0.1 A)
Insulation resistance	1000 MΩ min. (DC 500 V)
Dielectric withstand voltage)	AC 750 V for 1 minute

■ MATERIALS

Item	Materials	
Insulator	Polyester (UL94V-0)	
Conductor	Copper alloy	
Plating	Contact	Gold plating
	Terminal	Palladium plating

240 Series (SCA.1)

SOCKET, VERTICAL MOUNT

■ DIMENSIONS

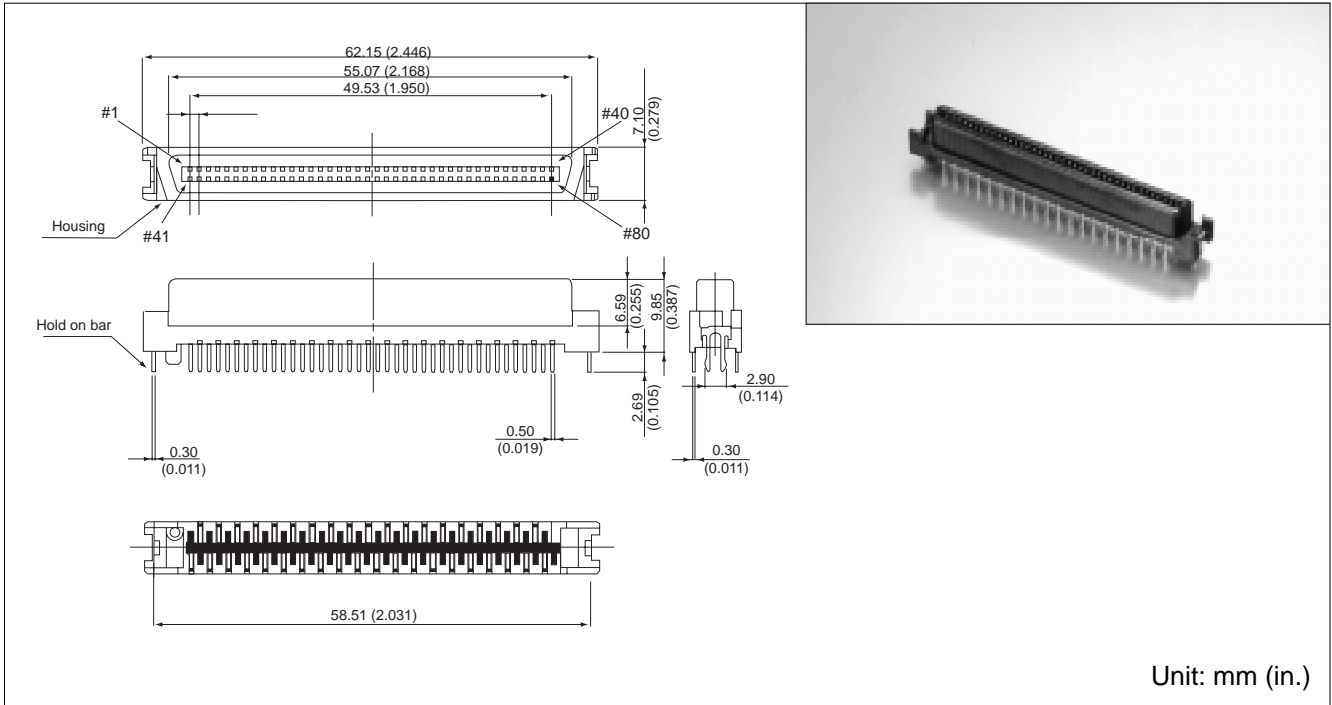

■ PC BOARD LAYOUT

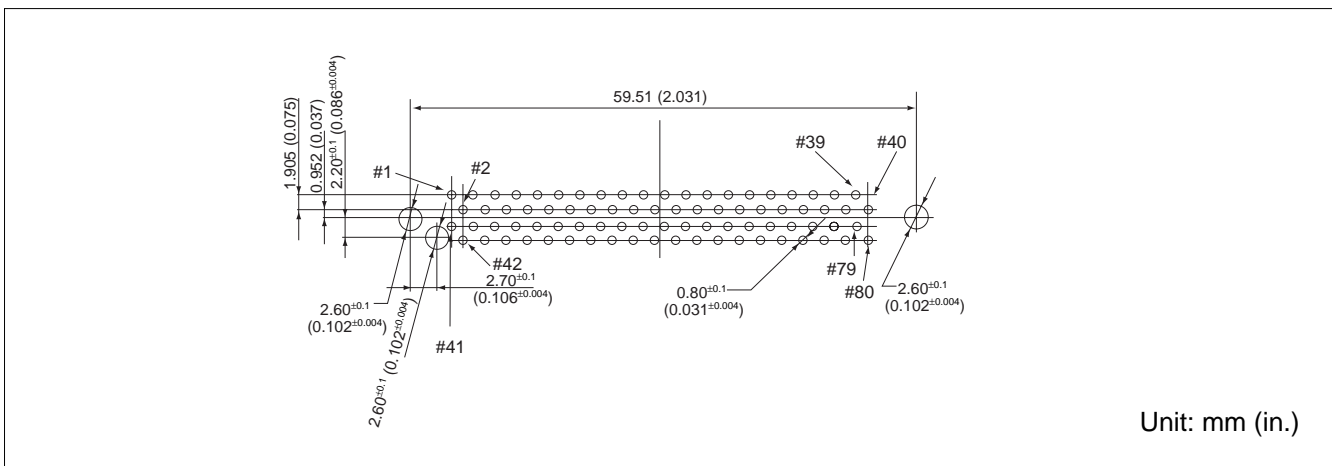

■ PART NUMBER

FCN-244B080-G/AS

240 Series

Fujitsu Components International Headquarter Offices

Japan

Fujitsu Component Limited
Gotanda-Chuo Building
3-5, Higashigotanda 2-chome, Shinagawa-ku
Tokyo 141, Japan
Tel: (81-3) 5449-7010
Fax: (81-3) 5449-2626
Email: promothq@ft.ed.fujitsu.com
Web: www.fcl.fujitsu.com

North and South America

Fujitsu Components America, Inc.
250 E. Caribbean Drive
Sunnyvale, CA 94089 U.S.A.
Tel: (1-408) 745-4900
Fax: (1-408) 745-4970
Email: marcom@fcai.fujitsu.com
Web: www.fcai.fujitsu.com

Europe

Fujitsu Components Europe B.V.
Diamantlaan 25
2132 WV Hoofddorp
Netherlands
Tel: (31-23) 5560910
Fax: (31-23) 5560950
Email: info.marketing@fceu.fujitsu.com
Web: www.fceu.fujitsu.com

Asia Pacific

Fujitsu Components Asia Ltd.
102E Pasir Panjang Road
#04-01 Citilink Warehouse Complex
Singapore 118529
Tel: (65) 375-8560
Fax: (65) 273-3021
Email: fcal@fcal.fujitsu.com
www.fcal.fujitsu.com

© 2001 Fujitsu Components America, Inc. All company and product names are trademarks or registered trademarks of their respective owners. Rev. 09/2001