

CMOS 5 x 7 Small Alphanumeric Displays

Technical Data

HCMS-270X Series
HCMS-271X Series
HCMS-272X Series

Features

- **On-Board Low Power CMOS ICs**
Integrated Shift Registers with Constant Current LED Drivers
- **Wide Operating Temperature Range**
-40°C to +85°C
- **Three Package Styles**
1 Row of 4 Characters
1 Row of 8 Characters
2 Rows of 8 Characters
- **Five LED Colors**
Standard Red
High Efficiency Red
Orange
Yellow
High Performance Green
- **5 x 7 LED Matrix**
Displays Full ASCII Character Set
- **Character Height**
3.8 mm (0.15 inch)
- **Long Viewing Distance**
2.6 Metres (8.6 Feet)
- **Wide Viewing Angle**
X Axis = $\pm 30^\circ$
Y Axis = $\pm 55^\circ$
- **Categorized for Luminous Intensity**

- **Categorized for Color**
HCMS-2701/-2703
HCMS-2711/-2713
HCMS-2721/-2723

Typical Applications

- **Telecommunications Equipment**
- **Instrumentation**
- **Medical Instruments**
- **Business Machines**



Device Selection Guide

Part Number	Display Package Style	LED Color
HCMS-2700 -2701 -2702 -2703 -2704	1 Row of 4 Characters	Standard Red Yellow HER Green Orange
HCMS-2710 -2711 -2712 -2713 -2714	1 Row of 8 Characters	Standard Red Yellow HER Green Orange
HCMS-2720 -2721 -2722 -2723 -2724	2 Rows of 8 Characters	Standard Red Yellow HER Green Orange

Description

The HCMS-270X series are four character 5x7 dot matrix alphanumeric displays in a dual in-line 12 pin plastic package. The on-board CMOS ICs form a 28 bit shift register.

The HCMS-271X series are eight character 5x7 dot matrix alphanumeric displays in a dual in-line plastic package with 26 pin positions. The on-board CMOS ICs form a 56 bit shift register.

The HCMS-272X series are sixteen character 5x7 dot matrix alphanumeric displays. Each device is assembled by enclosing two HCMS-271X devices in a common lens assembly forming two rows of eight characters. The plastic package has two dual in-line rows of 26 pin positions for a total of 52 pin positions. The two on-board CMOS IC 56 bit shift registers for each row are electrically separate from each other.

The on-board CMOS ICs form serial input shift registers with constant current output LED row drivers. Decoded column data is clocked into the shift registers for each refresh cycle. Full character display is accomplished with external column strobing at a refresh rate of 100 Hz or faster.

All of these display devices may be end stacked in the X-direction to form a string of characters of desired length.

Package Dimensions

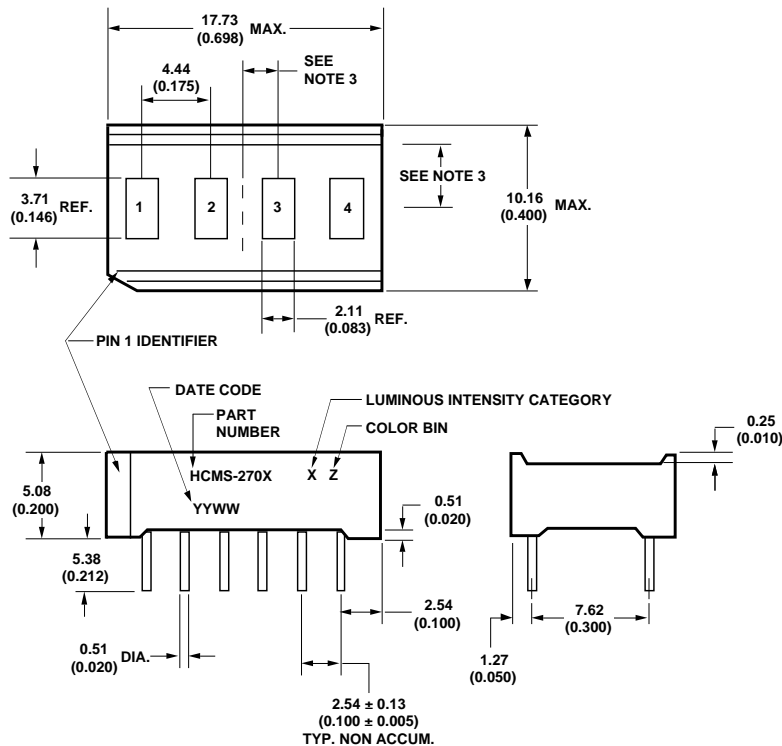

PIN	FUNCTION	PIN	FUNCTION
1	COLUMN 1	7	DATA OUT
2	COLUMN 2	8	V _B
3	COLUMN 3	9	V _{DD}
4	COLUMN 4	10	CLOCK
5	COLUMN 5	11	GROUND
6	INT. CONNECT*	12	DATA IN

* DO NOT CONNECT OR USE.

- NOTES:
1. DIMENSIONS IN MILLIMETRES/INCHES.
 2. UNLESS OTHERWISE SPECIFIED THE TOLERANCE ON ALL DIMENSIONS IS 0.38MM (0.015").
 3. CHARACTERS ARE CENTERED WITH RESPECT TO LEAD WITHIN 0.13MM (0.005").
 4. LEAD MATERIAL: SOLDER PLATED COPPER ALLOY.

HCMS-270X

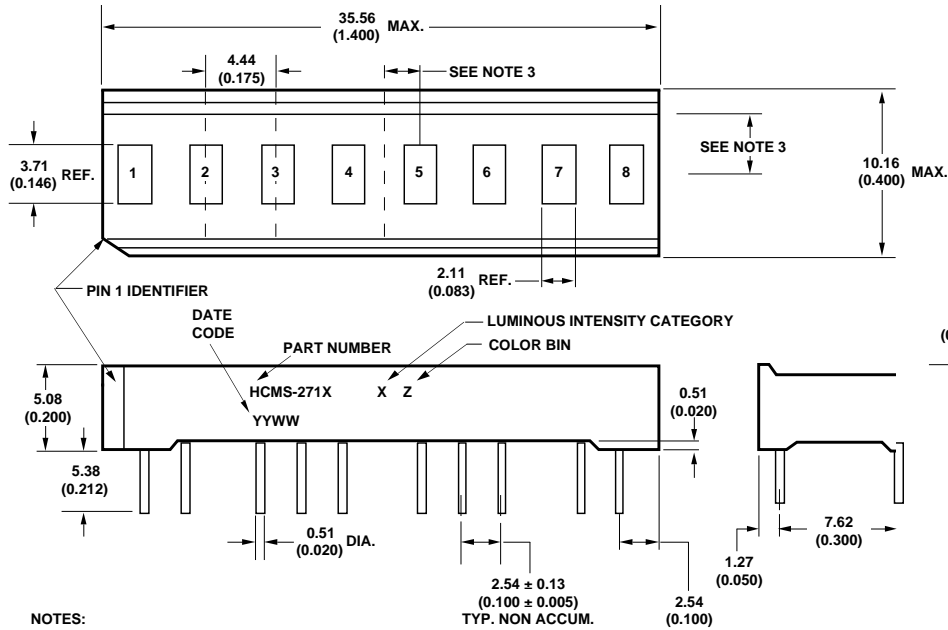

- NOTES:
 1. DIMENSIONS IN MILLIMETRES/INCHES.
 2. UNLESS OTHERWISE SPECIFIED THE TOLERANCE ON ALL DIMENSIONS IS 0.38MM (0.015").
 3. CHARACTERS ARE CENTERED WITH RESPECT TO LEAD WITHIN 0.13MM (0.005").
 4. LEAD MATERIAL: SOLDER PLATED COPPER ALLOY.

HCMS-271X

PIN	FUNCTION	PIN	FUNCTION
1	NO PIN	14	DATA OUT
2	COLUMN 2	15	V _B (5-8)
3	NO PIN	16	NO PIN
4	COLUMN 4	17	CLOCK
5	NO PIN	18	GROUND
6	INT. CONNECT*	19	NO PIN
7	NO PIN	20	NO PIN
8	COLUMN 1	21	INT. CONNECT*
9	NO PIN	22	V _B (1-4)
10	COLUMN 3	23	V _{DD}
11	NO PIN	24	NO PIN
12	COLUMN 5	25	GROUND
13	INT. CONNECT*	26	DATA IN

* DO NOT CONNECT OR USE.

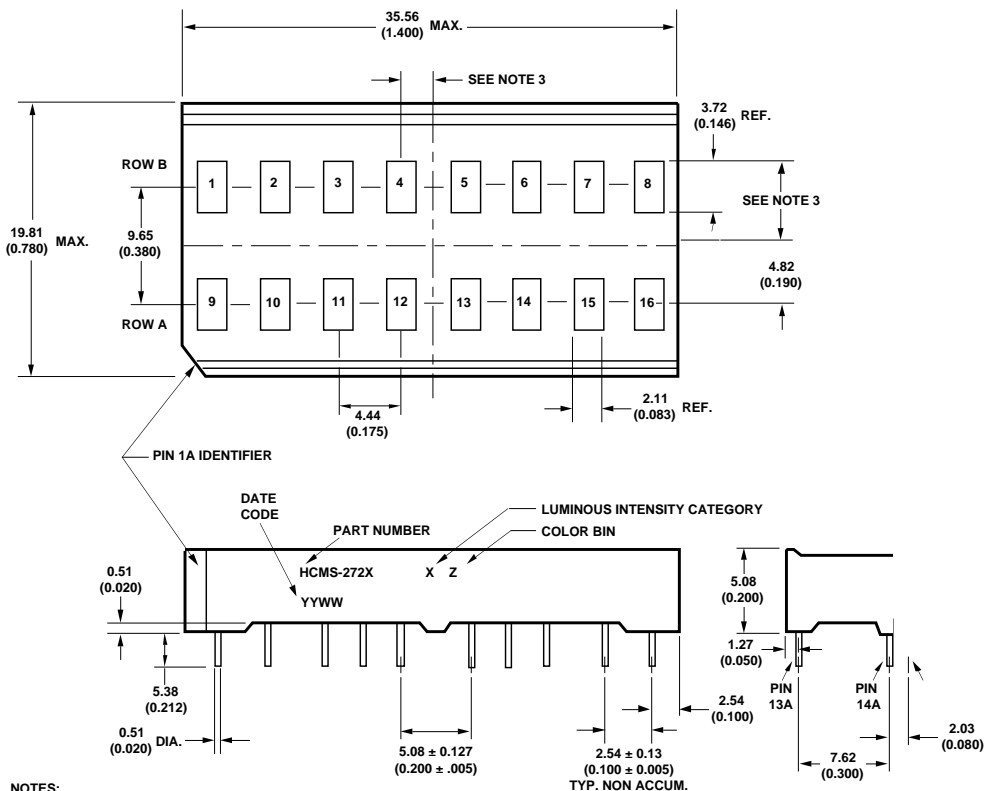

- NOTES:
 1. DIMENSIONS ARE IN MILLIMETRES/INCHES.
 2. UNLESS OTHERWISE SPECIFIED, TOLERANCE IS ± 0.38MM (0.015").
 3. CHARACTERS ARE POSITIONED WITH RESPECT TO LEADS WITHIN ± 0.13MM (0.005").
 4. LEAD MATERIAL IS SOLDER PLATED COPPER ALLOY.

HCMS-272X

PIN	FUNCTION	PIN	FUNCTION
1A	NO PIN	1B	NO PIN
2A	COLUMN 2	2B	COLUMN 2
3A	NO PIN	3B	NO PIN
4A	COLUMN 4	4B	COLUMN 4
5A	NO PIN	5B	NO PIN
6A	INT. CONNECT*	6B	INT. CONNECT*
7A	NO PIN	7B	NO PIN
8A	COLUMN 1	8B	COLUMN 1
9A	NO PIN	9B	NO PIN
10A	COLUMN 3	10B	COLUMN 3
11A	NO PIN	11B	NO PIN
12A	COLUMN 5	12B	COLUMN 5
13A	INT. CONNECT*	13B	INT. CONNECT*
14A	DATA OUT	14B	DATA OUT
15A	V _B (13-16)	15B	V _B (5-8)
16A	NO PIN	16B	NO PIN
17A	CLOCK	17B	CLOCK
18A	GROUND	18B	GROUND
19A	NO PIN	19B	NO PIN
20A	NO PIN	20B	NO PIN
21A	INT. CONNECT*	21B	INT. CONNECT*
22A	V _B (9-12)	22B	V _B (1-4)
23A	V _{DD}	23B	V _{DD}
24A	NO PIN	24B	NO PIN
25A	GROUND	25B	GROUND
26A	DATA IN	26B	DATA IN

* DO NOT CONNECT OR USE INTERNAL CONNECTION PINS.

Absolute Maximum Ratings

Supply Voltage V_{DD} to Ground	-0.3 V to 7.0 V
Data Input, Clock, Data Output, V_B	-0.3 V to V_{DD}
Column Input Voltage, V_{COL}	-0.3 V to V_{DD}
Free Air Operating Temperature, T_A	-40°C to +85°C
Storage Temperature, T_S	-55°C to +100°C
Maximum Allowable Package Power Dissipation, P_D at 55°C ^[1,2]	
HCMS-270X	0.837 W
HCMS-271X	1.674 W
HCMS-272X (per 8 character row)	1.674 W
(total per package)	3.348 W
Maximum Solder Temperature	
1.59 mm (0.063") Below Seating Plane, $t < 5$ sec	260°C
ESD Protection @ 1.5 k Ω , 100 pF	$V_Z = 4$ kV (each pin)

Notes:

- Maximum allowable power dissipation is derived from $V_{DD} = 5.25$ V and $V_B = 2.4$ V, $V_{COL} = 3.5$ V, 20 LEDs illuminated per character, 20% on-time duty factor.
- See Figure 1 for power derating. Thermal resistance from device V_{DD} pin(s) to ambient through the PC board mounting assembly is assumed to be $R_{\theta PC-A} \leq 35^\circ\text{C/W}$ per device for the HCMS-270X, $\leq 17.5^\circ\text{C/W}$ per device for the HCMS-271X, and $\leq 17.5^\circ\text{C/W}$ per row for the HCMS-272X.

Recommended Operating Conditions, $T_A = -40^\circ\text{C}$ to $+85^\circ\text{C}$

Description	Symbol	Minimum	Nominal	Maximum	Unit
Supply Voltage	V_{DD}	4.75	5.0	5.25	V
Data Out Current, Low State	I_{OL}			1.6	mA
Data Out Current, High State	I_{OH}			-0.5	mA
Column Input Voltage	V_{COL}	2.75	3.0	3.5	V
Setup Time	t_{SETUP}	10			ns
Hold Time	t_{HOLD}	25			ns
Clock Pulse Width High	$t_{WH(CLOCK)}$	50			ns
Clock Pulse Width Low	$t_{WL(CLOCK)}$	50			ns
Clock High to Low Transition	t_{THL}			200	ns
Clock Frequency	f_{CLOCK}			5	MHZ

Electrical Characteristics, -40°C to $+85^\circ\text{C}$

Parameter	Symbol	Test Conditions	Min.	Typ. ^[1]	Max.	Unit
Supply Current, Dynamic ^[2]	I_{DDD}	$V_{DD} = 5.25$ V $f_{CLOCK} = 5$ MHz $V_B = 0.4$ V				mA
HCMS-270X				6.2	7.8	
HCMS-271X				12.4	15.6	
HCMS-272X (per row)				15.6	15.6	
Supply Current, Static ^[3]	I_{DDSoFF}	$V_{DD} = 5.25$ V $V_B = 0.4$ V				mA
HCMS-270X				1.8	2.6	
HCMS-271X				3.6	5.2	
HCMS-272X (per row)		3.6	5.2			
HCMS-270X	I_{DDSoN}	$V_{DD} = 5.25$ V $V_B = 2.4$ V				mA
HCMS-271X				2.2	6.0	
HCMS-272X (per row)				4.4	12.0	
HCMS-272X (per row)		4.4	12.0			

Electrical Characteristics, -40°C to +85°C (cont'd.)

Parameter	Symbol	Test Conditions	Min.	Typ. ^[1]	Max.	Unit
Column Input Current HCMS-270X HCMS-271X HCMS-272X (per row)	I_{COL}	$V_{DD} = 5.25$ $V_{COL} = 3.5$ V $V_B = 2.4$ V		335 670 670	410 820 820	mA
Input Logic High: Data, V_B , Clock	V_{IH}	$V_{DD} = 4.75$ V	2.0			V
Input Logic Low: Data, V_B , Clock	V_{IL}	$V_{DD} = 5.25$ V			0.8	V
Input Current: Data Clock HCMS-270X HCMS-271X HCMS-272X (per row) V_B HCMS-270X HCMS-271X HCMS-272X (per row)	I_I	$V_{DD} = 5.25$ V $0 < V_I < 5.25$ V	-10		+1	μ A
$V_{DD} = 5.25$ V $0 < V_I < 5.25$ V		-10 -20 -20		+1		
$V_{DD} = 5.25$ V $0 < V_B < 5.25$ V		-40 -80 -80		0		
Data Out Voltage	V_{OH}	$V_{DD} = 4.75$ V $I_{OH} = -0.5$ mA $I_{COL} = 0$ mA	2.4	4.2		V
	V_{OL}	$V_{DD} = 5.25$ V $I_{OH} = 1.6$ mA $I_{COL} = 0$ mA		0.2	0.4	
Power Dissipation ^[4] Per Package HCMS-270X HCMS-271X HCMS-272X (per row)	P_D	$V_{DD} = 5.0$ V $V_{COL} = 3.5$ V 17.5% DF $V_B = 2.4$ V 15 LEDs ON Per Character		451 902 902		mW
Thermal Resistance ^[5] IC Junction-to-Pin (V_{DD}) HCMS-270X HCMS-271X HCMS-272X (per row)	$R\theta_{J-PIN}$			50		$^{\circ}$ C/W
				25		
				25		

Notes:

- All typical values at $V_{DD} = 5.0$ V, $T_A = 25^{\circ}$ C.
- I_{DD} Dynamic is the IC current while clocking column data through the on-board shift register at a clock frequency of 5 MHz.
- I_{DD} Static is the IC current after column data is loaded and not being clocked through the on-board shift register.
- Four, eight, or sixteen characters are illuminated with a typical ASCII character composed of 15 dots per character.
- The IC junction temperature $T_J(IC)$, is:

$$T_J(IC) = (P_D)(R\theta_{J-PIN} + R\theta_{PC-A}) + T_A$$

Where: P_D is the total power into the display for HCMS-270X and HCMS-271X,
and the total power into one row of an HCMS-272X display.

$$P_D = P(I_{DDSON}) + P(I_{COL})$$

$$P(I_{DDSON}) = I_{DDSON} * V_{DD}$$

$$P(I_{COL}) = 5 * I_{COL} * V_{COL} * n / 35 * DF$$

n = Quantity of LED dots illuminated per character.

DF = LED on-time duty factor.

The IC junction temperature rise above the temperature of the V_{DD} pin(s), $\Delta T_J(IC)$, is:

$$\Delta T_J(IC) = (P_D)(R\theta_{J-PIN})$$

The IC junction temperature, $T_J(IC)$, must not exceed +125°C.

Optical Characteristics at $T_A = 25^\circ\text{C}$

Standard Red HCMS-2700/-2710/-2720

Description	Test Conditions	Symbol	Min.	Typ.	Unit
Peak Luminous Intensity per LED (Digit Average) ^[1,5]	$V_{DD} = 5.0\text{ V}, V_{COL} = 3.5\text{ V}$ $V_B = 2.4\text{ V}, T_i = 25^\circ\text{C}^{[3]}$	I_v	105	200	μcd
Dominant Wavelength ^[4]		λ_d		640	nm
Peak Wavelength		λ_{PEAK}		65	nm

Yellow HCMS-2701/-2711/-2721

Description	Test Conditions	Symbol	Min.	Typ.	Unit
Peak Luminous Intensity per LED (Digit Average) ^[1,5]	$V_{DD} = 5.0\text{ V}, V_{COL} = 3.5\text{ V}$ $V_B = 2.4\text{ V}, T_i = 25^\circ\text{C}^{[3]}$	I_v	400	750	μcd
Dominant Wavelength ^[2,4]		λ_d		585	nm
Peak Wavelength		λ_{PEAK}		583	nm

High Efficiency Red HCMS-2702/-2712/-2722

Description	Test Conditions	Symbol	Min.	Typ.	Unit
Peak Luminous Intensity per LED (Digit Average) ^[1,5]	$V_{DD} = 5.0\text{ V}, V_{COL} = 3.5\text{ V}$ $V_B = 2.4\text{ V}, T_i = 25^\circ\text{C}^{[3]}$	I_v	400	1430	μcd
Dominant Wavelength ^[4]		λ_d		625	nm
Peak Wavelength		λ_{PEAK}		635	nm

High Performance Green HCMS-2703/-2713/-2723

Description	Test Conditions	Symbol	Min.	Typ.	Unit
Peak Luminous Intensity per LED (Digit Average) ^[1,5]	$V_{DD} = 5.0\text{ V}, V_{COL} = 3.5\text{ V}$ $V_B = 2.4\text{ V}, T_i = 25^\circ\text{C}^{[3]}$	I_v	400	1550	μcd
Dominant Wavelength ^[2,4]		λ_d		574	nm
Peak Wavelength		λ_{PEAK}		568	nm

Orange HCMS-2704/-2714/-2724

Description	Test Conditions	Symbol	Min.	Typ.	Unit
Peak Luminous Intensity per LED (Digit Average) ^[1,5]	$V_{DD} = 5.0\text{ V}, V_{COL} = 3.5\text{ V}$ $V_B = 2.4\text{ V}, T_i = 25^\circ\text{C}^{[3]}$	I_v	400	1400	μcd
Dominant Wavelength ^[4]		λ_d		602	nm
Peak Wavelength		λ_{PEAK}		600	nm

Notes:

1. These displays are categorized for luminous intensity with the intensity category designated by a letter code located on the side of the display package.
2. Yellow and high performance green devices are categorized for color with the color category designated by a number code on the side of the display package.
3. T_i refers to the initial device temperature immediately prior to the light measurement.
4. Dominant wavelength, λ_d , is derived from the CIE chromaticity diagram and is that single wavelength which defines the LED color.
5. The luminous sterance of the individual LED pixels may be calculated using the following equations:

$$L_v(\text{cd}/\text{m}^2) = I_v(\text{Candela}) * \text{DF} / \text{A}(\text{Meter}^2)$$

$$L_v(\text{Footlamberts}) = \pi I_v(\text{Candela}) * \text{DF} / \text{A}(\text{Foot}^2)$$

Where: A = LED pixel area = $3.32 \times 10^{-8} \text{ m}^2$ or $3.57 \times 10^{-7} \text{ ft}^2$

DF = LED on-time duty factor.

Switching Characteristics, $T_A = -40^\circ\text{C}$ to $+85^\circ\text{C}$

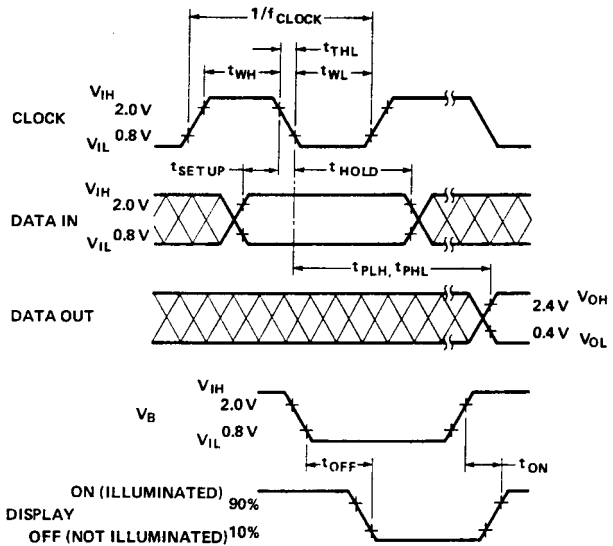

Parameter	Condition	Typ.	Max.	Units
f_{CLOCK} CLOCK Rate			5	MHz
$t_{\text{PLH}}, t_{\text{PHL}}$ Propagation Delay CLOCK to DATA OUT	$C_L = 15 \text{ pF}$ $R_L = 2.4 \text{ k}\Omega$		105	ns
t_{OFF} V_B (0.4 V) to Display OFF		4	5	μs
t_{ON} V_B (2.4 V) to Display ON		1	2	

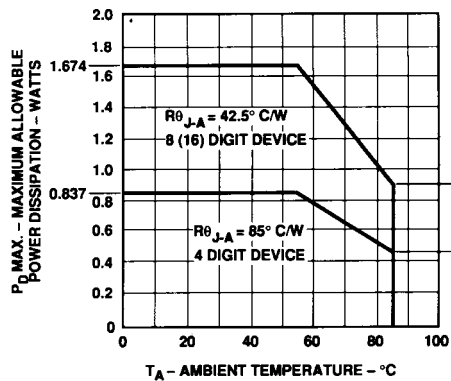

Figure 1. Maximum Allowable Power Dissipation vs. Ambient Temperature as a Function of Thermal Resistance IC Junction-to-Ambient, $R_{\theta_{J-A}}$. Operation at 85°C Assumes a Thermal Resistance for the Printed Circuit Board of $R_{\theta_{PC-A}} = 35^\circ\text{C/W}$ Per Device for the HCMS-270X, 17.5°C/W Per Device for the HCMS-271X, and 17.5°C/W Per Row for the HCMS-272X.

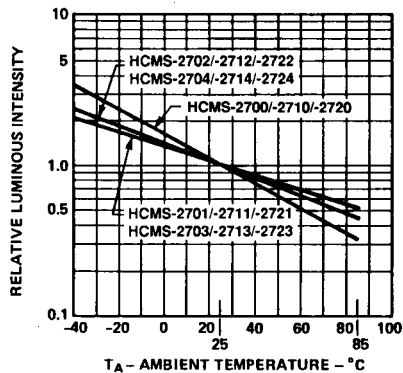

Figure 2. Relative Luminous Intensity vs. Display Pin Temperature.

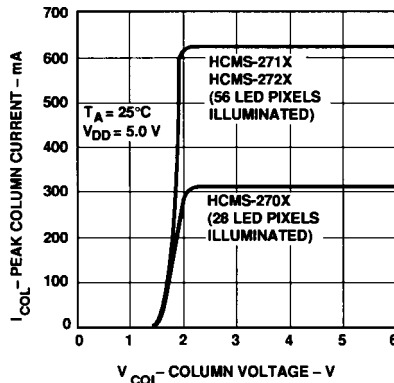

Figure 3. Peak Column Current vs. Column Voltage.

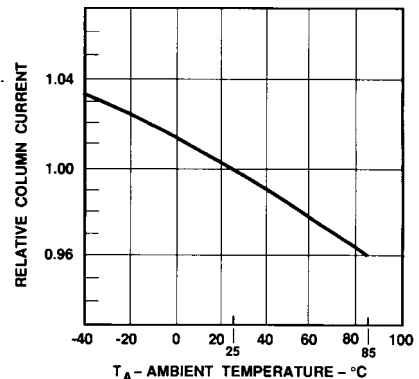

Figure 4. Relative Column Current, I_{COL} , vs. Ambient Temperature.

Electrical Description

Each display device contains four or eight 5x7 LED dot matrix characters and two or four CMOS integrated circuits, as shown in Figure 5. The CMOS integrated circuits form an on-board 28 bit or 56 bit serial-in-parallel-out shift register that will accept standard TTL logic levels. The Data Input pin is connected to bit position 1 and the Data Output pin is connected to bit position 28 (56). The shift register outputs control constant current sinking LED row drivers. The nominal current sink per LED driver is 11 mA. A logic 1 stored in the shift register enables the corresponding LED row driver and a logic 0 stored in the shift register disables the corresponding LED row driver.

The electrical configuration of these CMOS IC alphanumeric displays allows for an effective interface to a display controller circuit that supplies decoded character information. The row data for a given column (one 7 bit byte per character) is loaded (bit serial) into the on-board 28 (56) bit shift register with high to low transitions of the Clock input. To load decoded character information into the display, column data for character 4 (8) is loaded first and the column data for character 1 is loaded last in the following manner. The 7 data bits for column 1, character 4 (8), are loaded into the on-board shift register. Next, the 7 data bits for column 1, character 3 (7), are loaded into the shift register, shifting the character 4 (8) data bits over one character position.

This process is repeated for the other 2 (6) characters until all 28 (56) bits of column data (four or eight 7 bit bytes of character column data) are loaded into the on-board shift register. Then the column 1 input, V_{COL} , pin 1, is energized to illuminate column 1 in all 4 (8) characters. This process is repeated for columns 2, 3, 4, and 5. All of the V_{COL} inputs should be at logic low to insure the display is off when loading data. The display will be blanked when the blanking input V_B is at logic low regardless of the outputs of the shift register or whether one of the V_{COL} inputs is energized.

Refer to Application Note 1016 *Using the HDSP-2000 Alphanumeric Display Family* for drive circuit information.

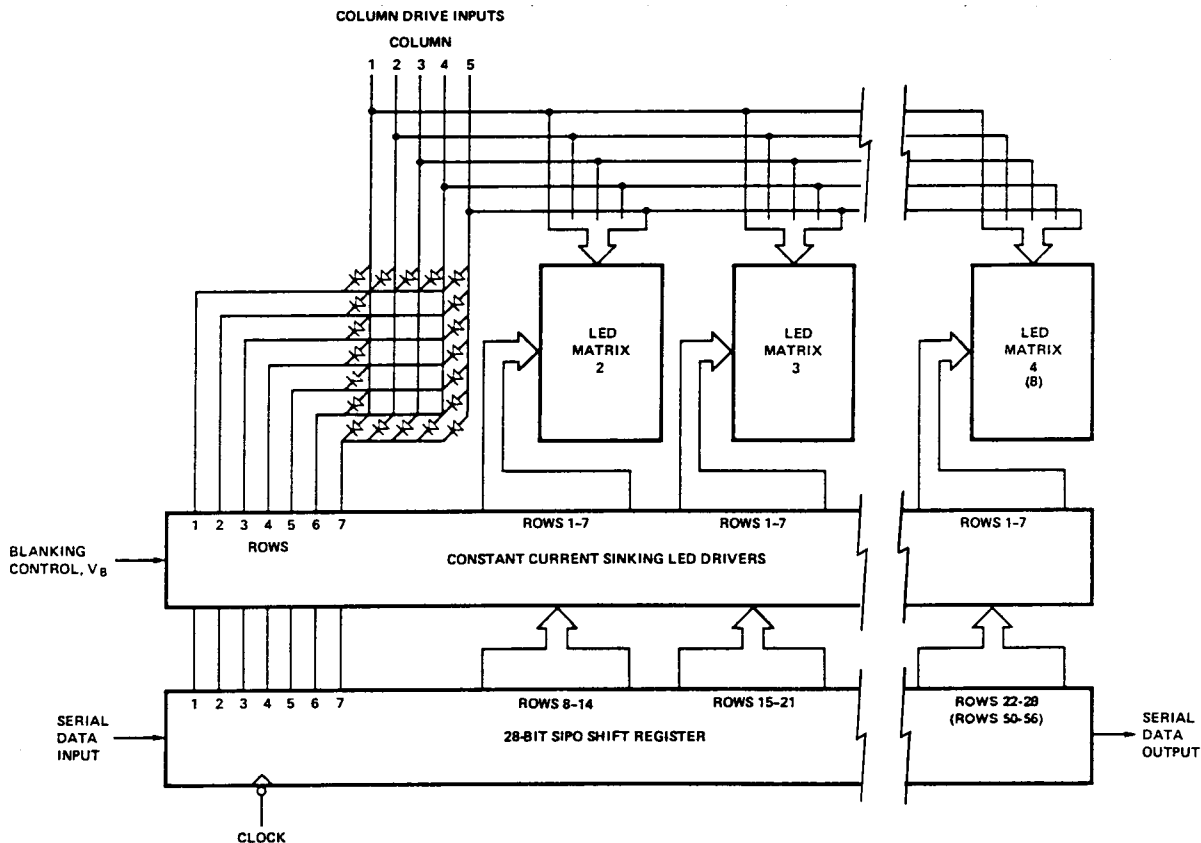

Figure 5. Block Diagram of an HCMS-27XX Series LED Alphanumeric Display.

ESD Susceptibility

The HCMS-27XX series displays have an ESD susceptibility ratings of CLASS 3 per DOD-STD-1686 and CLASS B per MIL-STD-883C. It is recommended that normal CMOS handling precautions be observed with these devices.

Soldering and Post Solder Cleaning

For information on soldering and post-solder cleaning of LED Displays, see Application Note 1027: *Soldering LED Components*.

Contrast Enhancement

When used with the proper contrast enhancement filters, the HCMS-27XX series displays are readable in bright ambients. For information on contrast enhancement, refer to Application Note 1015 *Contrast Enhancement Techniques for LED Displays* and Application Note 1029 *Luminous Contrast and Sunlight Readability of the HDSP-238X Series Alphanumeric Displays for Military Applications*.

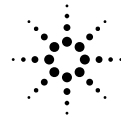

Agilent Technologies
Innovating the HP Way

www.semiconductor.agilent.com

Data subject to change.

Copyright © 1999 Agilent Technologies, Inc.

Obsoletes 5091-1095E

5964-6375E (11/99)