

SPECIFICATION CONTROL DRAWING

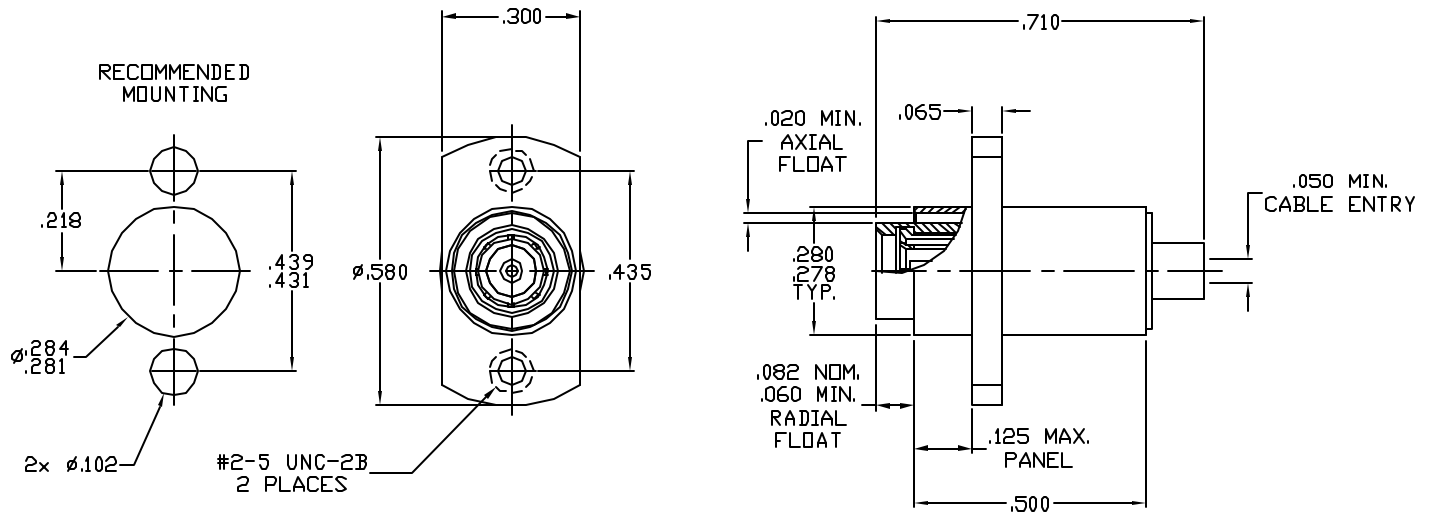

1. MATING INTERFACE DIMENSIONS PER DYNAWAVE SPECIFICATION MD-65 (BMAM JACK)

2. ELECTRICAL

FREQUENCY RANGE MHz _____ DC TO 28.0 GHz.

VSWR (MAX.) _____ SEE SHEET 3

INSERTION LOSS (dB MAX.)

- BMAM INTERFACE GAP (.000 TO .010) _____ $.055 \times \sqrt{FGHz}$.
- BMAM INTERFACE GAP (.011 TO .020) _____ $.070 \times \sqrt{FGHz}$.

NOMINAL IMPEDANCE (OHMS) _____ 50

VOLTAGE RATING (MAX. VRMS) _____ 170

RF LEAKAGE (MIN. dB DOWN)

- BMAM INTERFACE BOTTOMED (.000 GAP) _____ -90 dB - FGHz
- BMAM INTERFACE GAP (.001 TO .010) _____ -80 dB - FGHz
- BMAM INTERFACE GAP (.016 TO .020) _____ -75 dB - FGHz

TEMPERATURE RATING (DEGREES CENTIGRADE) _____ $-65^{\circ} c$ TO $+165^{\circ} c$

DIELECTRIC WITHSTANDING VOLTAGE (MAX. VRMS) _____ 500

INSULATION RESISTANCE (MIN. MEGOHMS) _____ 5,000

CONTACT RESISTANCE

- CENTER CONTACT (MAX. MILLIOHMS) _____ 6.0
- OUTER CONTACT (MAX. MILLIOHMS) _____ 3.0

- TERMINATED IN A 50 OHM LOAD

REV.	DCN NO.	DATE	APP.	DIMENSIONS ARE IN INCHES TOLERANCES			 <small>INCORPORATED</small> HAVERHILL, MA. 01835
AA	07-1451			DECIMALS	FRACTIONAL	ANGULAR	
				$.X^{\pm} .030$ $.XX^{\pm} .010$ $.XXX^{\pm} .005$	$\pm 1/64$	$X^{\circ} \pm 1^{\circ} 0'$ $X^{\circ} X' \pm 15'$	
				DRAWN	TS	DATE 4/26/07	
				APPROVED	DC	DATE 4/26/07	
				CODE IDENT.	SHEET 1 OF 3		TITLE BMAM JACK, 2 HOLE FLOATING FLANGE MOUNT DIRECT SOLDER TO .047 SEMI-RIGID CABLE DWG. NO. 6562-4721-6267
				2J899			

SPECIFICATION CONTROL DRAWING

3. MECHANICAL

CAPTIVATION-CENTER CONTACT

- MIN. AXIAL FORCE _____ 4.0 LBS.
- MIN. RADIAL TORQUE _____ N/A

CENTER CONTACT AXIAL FORCES

- INSERTION (MAX. OUNCES) _____ 32.0
- WITHDRAWAL (MIN. OUNCES) _____ 2.0

CONNECTOR DURABILITY (MIN. CYCLES) _____ 1,000

RECOMMENDED MATING TORQUE _____ N/A

4. ENVIRONMENTAL

TEMPERATURE CYCLING _____ MIL-STD-202, METHOD 102, COND. C (-65 ° c TO +200 ° c)

SHOCK _____ MIL-STD-202, METHOD 213, COND. I (100 G's)

VIBRATION _____ MIL-STD-202, METHOD 204, COND. D (20 G's)

MOISTURE RESISTANCE _____ MIL-STD-202, METHOD 106, LESS STEP 7b

CORROSION _____ MIL-STD-202, METHOD 101, COND. B (48 HOURS)

BAROMETRIC PRESSURE (ALTITUDE) _____ MIL-STD-202, METHOD 105, COND. C (70,000 FT.) (190 VRMS)

5. MATERIAL

BODY AND FLOAT HOUSING _____ STAINLESS STEEL PER ASTM-A-582, TYPE 303, COND. A

CONTACTS & SPRING FINGERS _____ BERYLLIUM COPPER PER ASTM B196/B, B196M-03, COPPER ALLOY No. UNS-C-17300, TEMPER TD04

INSULATOR _____ TEFLON PER ASTM D 1710-02, TYPE 1, GRADE 1, CLASS B

CONTACT HOOD _____ BRASS PER ASTM B16, TEMPER H02, ALLOY C36000.

COMPRESSION SPRING _____ STAINLESS STEEL PER ASTM-A-313, TYPE 302, AMS 5688 SPRING TEMPER.

6. FINISH

BODY _____ GOLD PER ASTM-B-488, TYPE I, CODE C, CLASS 1.25
(.000050 MIN. THK.) OVER NICKEL PER QQ-N-290
(.000150 MIN. THK.) OVER COPPER PER MIL-C-14550
(.000010 MIN. THK.)

CONTACTS & SPRING FINGERS _____ GOLD PER ASTM-B-488, TYPE I, CODE C, CLASS 2.5
(.000100 MIN. THK.) OVER NICKEL PER QQ-N-290
(.000050 MIN. THK.) OVER COPPER PER MIL-C-14550
(.000010 MIN. THK.)

FLOAT HOUSING _____ PASSIVATE PER AMS QQ-P-35, TYPE 2

INSULATOR _____ N/A

SPECIFICATION CONTROL DRAWING

