



MP5023

16V, 50A, 1.1mΩ,
Protection Device with Integrated MOSFET
and PMBus™ Interface

DESCRIPTION

The MP5023 is a hot-swap protection device designed to protect circuitry on its output from transients on its input. The MP5023 also protects its input from undesired shorts and transients coming from its output.

During start-up, inrush current is limited by the slew rate at the output. The slew rate is controlled by the external capacitor at SS.

The maximum load at the output is current-limited through on-die current sense technology. The magnitude of the current limit is controlled by a low-power resistor from ISET to ground.

An internal charge pump drives the gate of the power device, allowing for a power MOSFET with a very low on resistance of 1.1mΩ.

The MP5023 includes an IMON option that produces a voltage proportional to the current through the power device set by a resistor from IMON to ground.

The PMBus™ interface allows the MP5023 to read current, voltage, temperature data, and input power from the internal ADC.

The MP5023 includes an optional discharge function through the PMBus™ that provides a discharge path for the external output capacitor when the part is disabled.

Fault protection includes current limiting, thermal shutdown, and damaged MOSFET detection. Both current limit and thermal shutdown have auto-retry and latch-off modes via the PMBus™ interface that can be set by the user. The MP5023 also features over-voltage protection (OVP) and under-voltage protection (UVP).

The MP5023 is available in a small FCQFN-24 package (4mmx5mm).

FEATURES

- Input Voltage Range: 4V to 16V
- Integrated 1.1mΩ Power MOSFET
- Maximum 50A Output Current
- Adjustable Current Limit
- Output Current Measurement
- Fast Response (<200ns) for Short Protection
- PG Detector and Indication
- PG Asserts Low at VIN = 0
- Damaged MOSFET Detection
- External Soft Start (SS)
- PMBus™ 1.3 Compliant
- Configurable Over-Voltage Lockout with Hysteresis
- Real-Time Monitoring of VIN, VOUT, IOUT, and Temperature by PMBus™
- Auto-Retry or Latch-Off Mode in Over-Current Protection (OCP) through the PMBus™
- Programmable Start-Up Current Limit
- Thermal Protection
- Available in a FCQFN-24 (4mmx5mm) Package

APPLICATIONS

- Hot Swaps
- PC Cards
- Disk Drives
- Servers
- Networking
- Laptops

All MPS parts are lead-free, halogen-free, and adhere to the RoHS directive. For MPS green status, please visit the MPS website under Quality Assurance page. "MPS" and "The Future of Analog IC Technology" are registered trademarks of Monolithic Power Systems, Inc.

TYPICAL APPLICATION

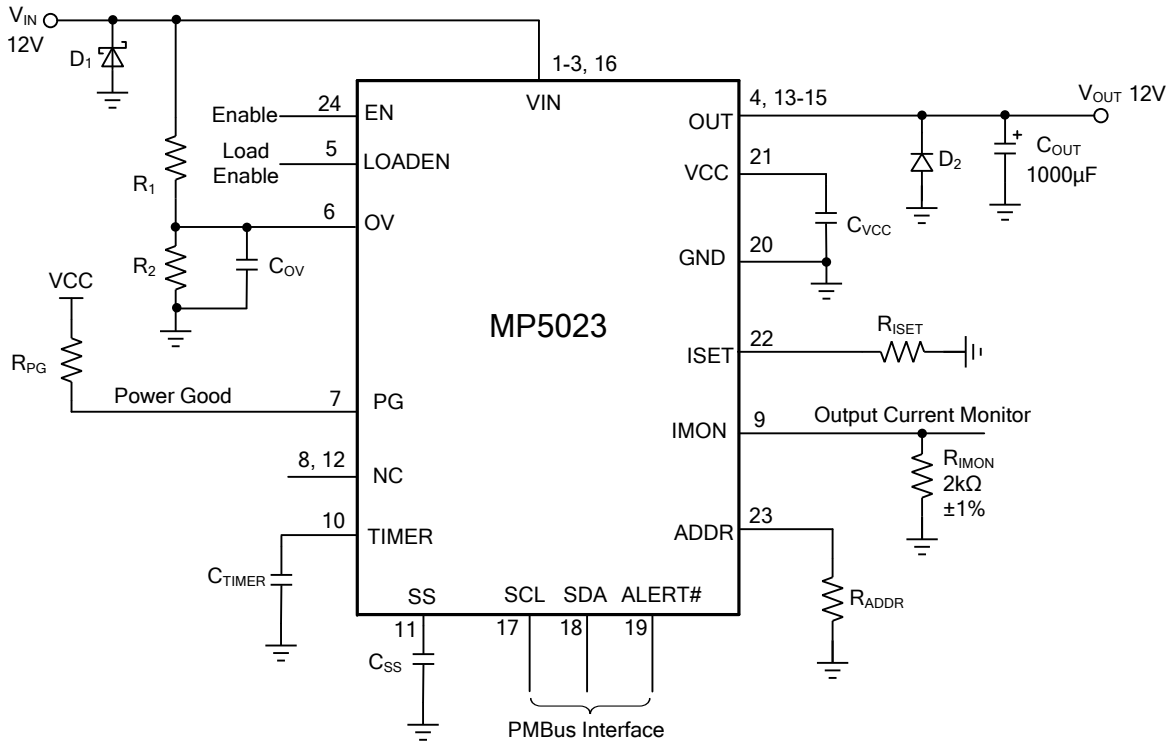

ORDERING INFORMATION

Part Number*	Package	Top Marking
MP5023GV-xxxx**	FCQFN-24 (4mmx5mm)	<i>See Below</i>

* For Tape & Reel, add suffix -Z (e.g. MP5023GV-xxxx-Z)

**: "xxxx" is the configuration code identifier for the register settings stored in the non-volatile memory (NVM). To create a unique value for this code, please contact an MPS FAE.

TOP MARKING

MPSYWW
MP5023
LLLLLL

MPS: MPS prefix
 Y: Year code
 WW: Week code
 MP5023: Part number
 LLLLLL: Lot number

PACKAGE REFERENCE

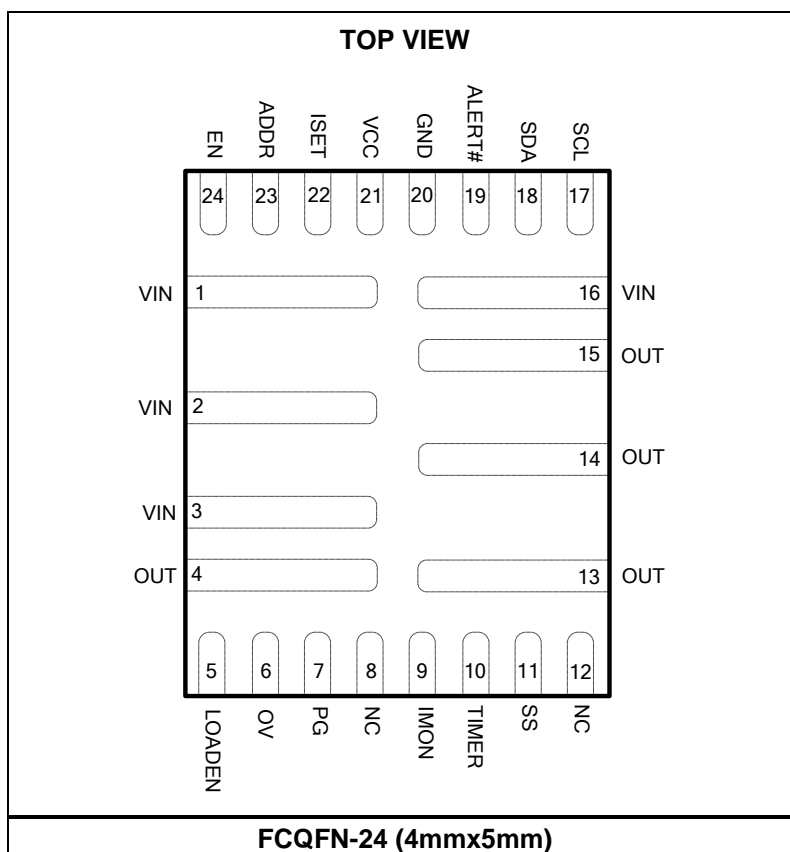

ABSOLUTE MAXIMUM RATINGS (1)

VIN (DC)	-0.3V to 20V
VIN (1μs).....	24V
VIN (25ns).....	29V
OUT	-0.3V to 20V
All other pins	-0.3V to +4.2V
Continuous power dissipation (T _A = +25°C) (2)	
.....	3.29W
Junction temperature	150°C
Lead temperature	260°C
Storage temperature.....	-65°C to +155°C

Recommended Operating Conditions (3)

Input voltage operating range	4V to 16V
Operating junction temp. (T _J)...	-40°C to +125°C

Thermal Resistance (4)	θ_{JA}	θ_{JC}	
FCQFN-24 (4mmx5mm).....	38.....	8....	°C/W

NOTES:

- 1) Exceeding these ratings may damage the device.
- 2) The maximum allowable power dissipation is a function of the maximum junction temperature T_J (MAX), the junction-to-ambient thermal resistance θ_{JA}, and the ambient temperature T_A. The maximum allowable continuous power dissipation at any ambient temperature is calculated by P_D (MAX) = (T_J (MAX)-T_A)/θ_{JA}. Exceeding the maximum allowable power dissipation produces an excessive die temperature, causing the regulator to go into thermal shutdown. Internal thermal shutdown circuitry protects the device from permanent damage.
- 3) The device is not guaranteed to function outside of its operating conditions.
- 4) Measured on JESD51-7 4-layer board.

ELECTRICAL CHARACTERISTICS

V_{IN} = 12V, R_{ISET} = 15kΩ, C_{OUT} = 1000μF, T_A = 25°C, unless otherwise noted.

Parameters	Symbol	Condition	Min	Typ	Max	Units
Supply Current						
Quiescent current	I _Q	EN = high, no load		3.5	5	mA
		EN = 0, V _{IN} = 16V		2	3	mA
VCC Regulator and UVLO						
VCC regulator	V _{CC}			3.35		V
VCC load regulation		I _{CC} = 15mA		5		%
VCC under-voltage lockout threshold rising	V _{CCVth}		2.5	2.6	2.7	V
VCC under-voltage lockout threshold hysteresis	V _{CCHYS}			200		mV
Power MOSFET						
On resistance	R _{DSon}	T _J = 25°C		1.1	1.35	mΩ
		T _J = 85°C ⁽⁵⁾		1.3	1.6	
Off-state leakage current	I _{OFF}	EN = 0V			1	μA
Maximum continuous current ⁽⁵⁾	I _{OUT_MAX}	With air flow			50	A
Thermal Shutdown and Recovery						
Shutdown temperature ⁽⁵⁾	t _{STD}			145		°C
Hysteresis ⁽⁵⁾	t _{HYS}	Auto-retry mode only		20		°C
Over-Voltage (OV)						
OV threshold	V _{OV_TH}	V _{OV} rising	1.15	1.21	1.27	V
OV threshold hysteresis	V _{OV_HYS}	V _{OV} falling		70		mV
LOADEN						
Low-level input voltage	V _L				0.9	V
High-level input voltage	V _H		2.3			V
LOADEN blanking time	T _{LDENBL}	F0h bit[5:4]=11		8		s
Soft Start (SS)						
SS pull-up current	I _{SS}	V _{IN} = 12V	12	14	16	μA
Current Limit						
Primary current limit at normal operation	I _{Limit_PRIM}	R _{ISET} = 15kΩ	39	43.5	48	A
Primary current limit response time ⁽⁵⁾	t _{CL_PRIM}	I _{Limit} = 50A		20		μs
Secondary current limit ⁽⁵⁾	I _{Limit_SCD}	Regardless of R _{ISET}		110		A
Short-circuit protection response time ⁽⁵⁾	t _{SC}			200		ns
Output Current Monitor						
Gain of the current sense amplifier	A _{IMON}	40 > I _{OUT} > 9A	9.7	10	10.3	μA/A
Offset of the current sense amplifier		40 > I _{OUT} > 9A		-3		μA
Max voltage of IMON	V _{IMON}				1.6	V

ELECTRICAL CHARACTERISTICS (continued)
V_{IN} = 12V, R_{ISET} = 15kΩ, C_{OUT} = 1000μF, T_J = 25°C, unless otherwise noted.

Parameters	Symbol	Condition	Min	Typ	Max	Units
Timer Pin For Insertion Delay and Fault Time						
Upper threshold voltage	V _{TMRH}		1.11	1.21	1.31	V
Insertion delay charge current	I _{INSERT}		33	43	53	μA
Fault detection charge current	I _{FLTD}			425		μA
Fault restart sink current	I _{FLTS}			0.3		μA
Discharge R _{DS(ON)}	R _{FLTE}	I _{OUT} < I _{Limit}		12		Ω
Enable (EN)						
Rising threshold	V _{ENRS}		1.11	1.21	1.31	V
Hysteresis	V _{ENHYS}			170		mV
PD Mode						
PD delay when the MOSFET is off by EN or LOADEN ⁽⁵⁾	t _{PD_DLY}	PD mode is configurable through PMBus™		4		ms
Power Good (PG)						
Low-level output voltage	V _{OL}	Sink current 1mA			0.2	V
Off-state leakage current	I _{PG_LKG}	V _{PG} = 3.3V			3	μA
PG low-level output voltage	V _{OL_100}	V _{IN} = 0V, pull up to 3.3V through a 100kΩ resistor		650	750	mV
	V _{OL_10}	V _{IN} = 0V, pull up to 3.3V through a 10kΩ resistor		750	900	mV
ADC for IMON⁽⁵⁾						
Voltage range			0		1.28	V
Resolution				10		bits
DNL				1		LSB
ADC sampling rate	t _{SR}			2.5		kHz
ADC for VIN, OUT, TEMP⁽⁵⁾						
Voltage range			0		1.28	V
Resolution				10		bits
DNL				1		LSB
ADC sampling rate	t _{SR}			10		kHz
PMBus™ DC Characteristics (SDA, SCL, ALERT#)						
Input high voltage	V _{IH}	SCL, SDA	2.1			V
Input low voltage	V _{IL}	SCL, SDA			0.8	V
Output low voltage	V _{OL}	ALERT#, I _{OL} = 1mA			0.4	V
Input leakage current	I _{LEAK}	SDA, SCL, ALERT# = 3.3V	-10		10	μA
Maximum voltage (SDA, SCL, ALERT#)	V _{MAX}	Transient voltage including ringing	-0.3	3.3	3.6	V
Pin capacitance on SDA,SCL	C _{PIN}				10	pF

ELECTRICAL CHARACTERISTICS (continued)

 VIN = 12V, R_{ISET} = 15kΩ, C_{OUT} = 1000μF, T_J = 25°C, unless otherwise noted.

Parameters	Symbol	Condition	Min	Typ	Max	Units
PMBus™ Timing Characteristics						
Operating frequency range			10		1000	kHz
Bus free time		Between stop and start condition	4.7			μs
Holding time			4.0			μs
Repeated start condition set-up time			4.7			μs
Clock low time out			20	25	30	ms
Clock low period			0.5			μs
Clock high period			0.5		50	μs
Clock/data fall time					300	ns
Clock/data rise time					1000	ns

NOTE:

5) Guaranteed by design.

TYPICAL CHARACTERISTICS

VIN = 12V, R_{IMON} = 2kΩ, T_A = +25°C, unless otherwise noted.

Quiescent Current vs. Temperature

EN = High

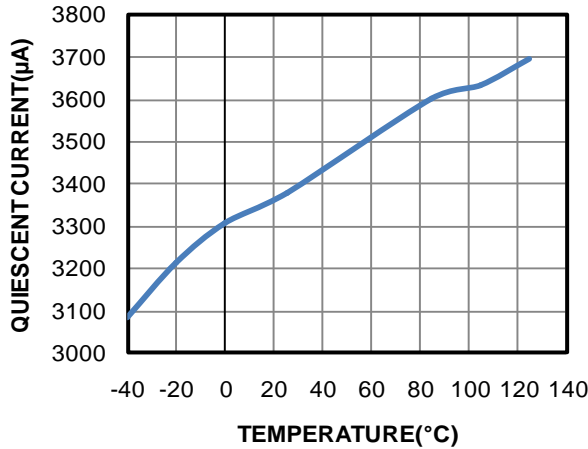

VIN Threshold vs Temperature

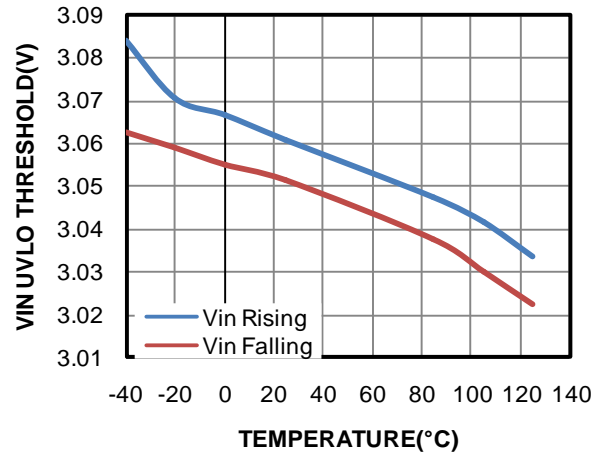

R_{DS(ON)} vs. Temperature

I_{OUT} = 0.5A

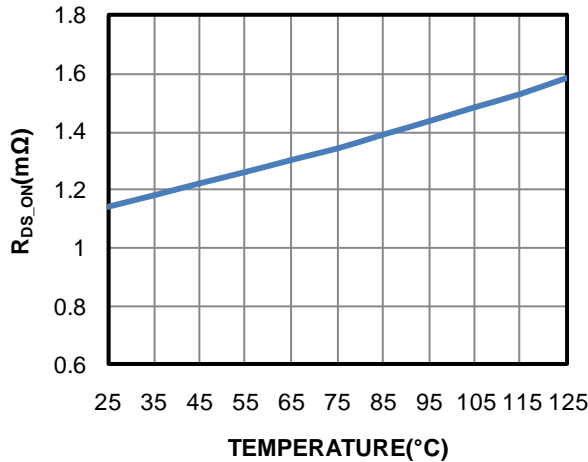

OV MOSFET On/Off Threshold vs. Temperature

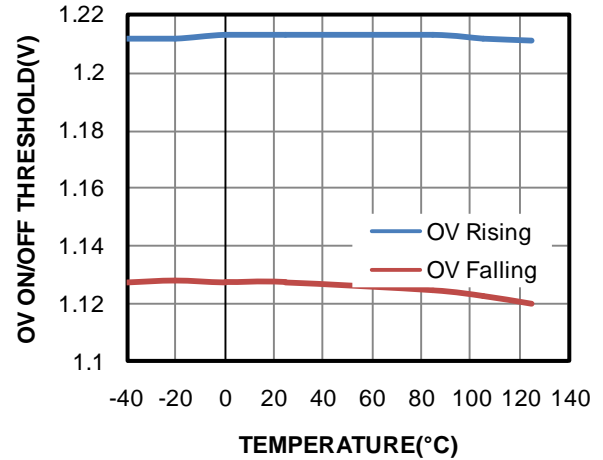

Safe Operation Area (SOA)

Tested on EV5023-V-01A

4-layers, 20Z each layer, 7.57cm*9.36cm

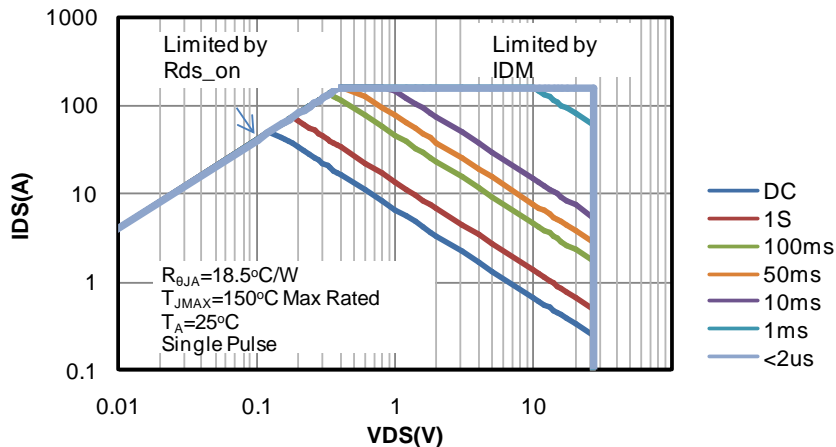

TYPICAL CHARACTERISTICS (continued)

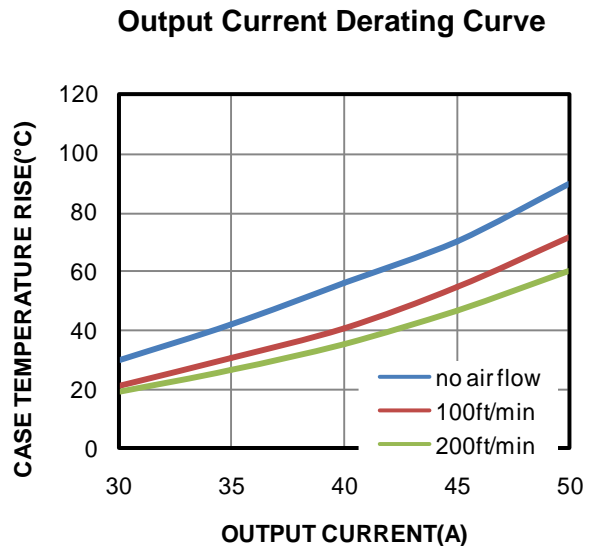
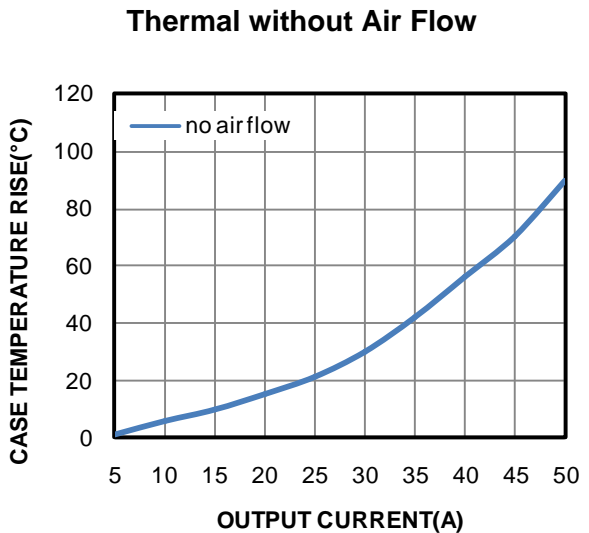
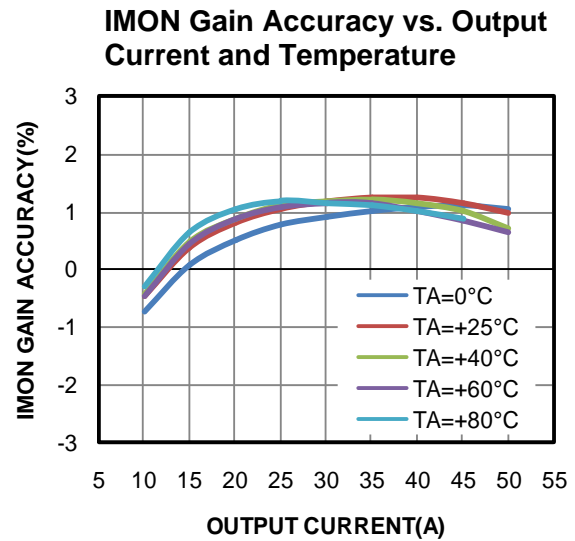
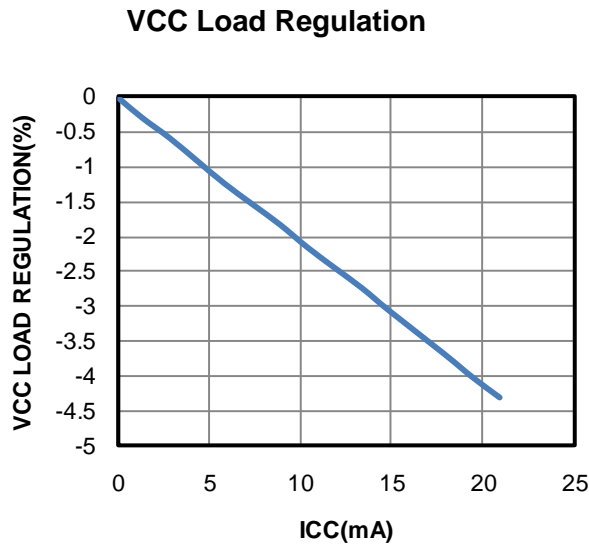
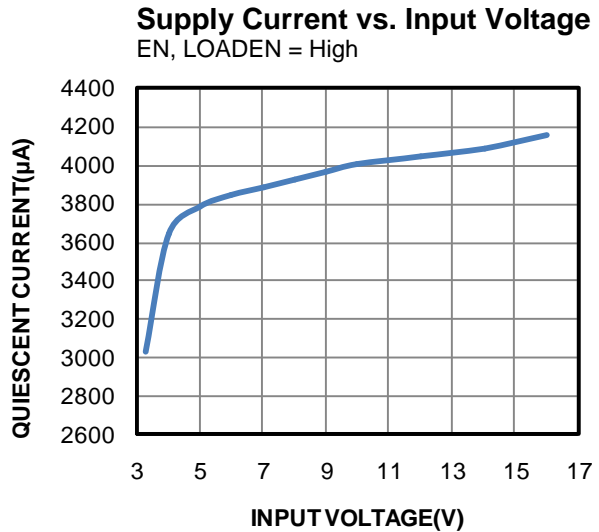
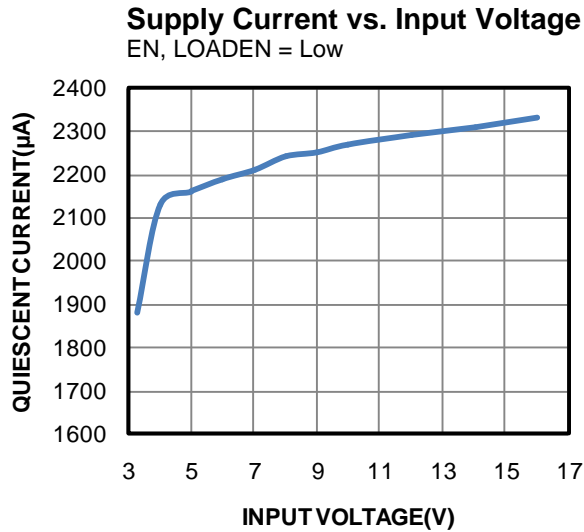
 VIN = 12V, R_{IMON} = 2kΩ, T_A = +25°C, unless otherwise noted.

TYPICAL PERFORMANCE CHARACTERISTICS (continued)

 VIN = 12V, C_{OUT} = 4700μF, CSS = 100nF, R_{IMON} = 2kΩ, T_A = +25°C, unless otherwise noted.

VIN Hot Plug

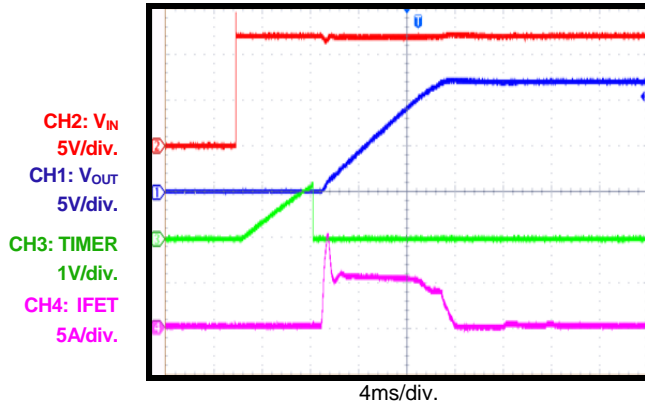
 I_{OUT} = 0A

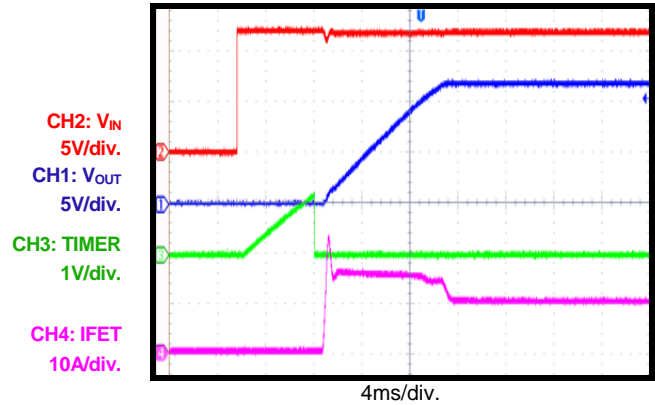
VIN Hot Plug

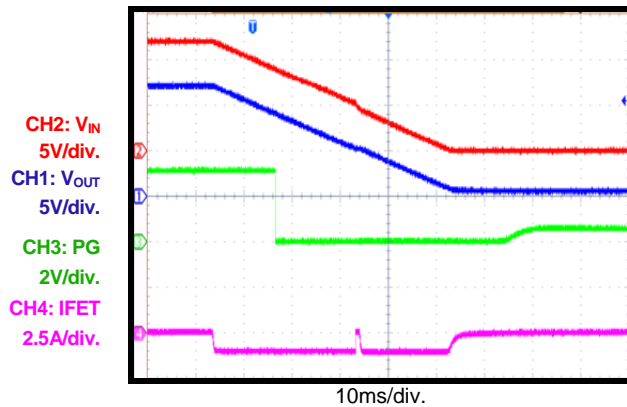
 I_{OUT} = 10A

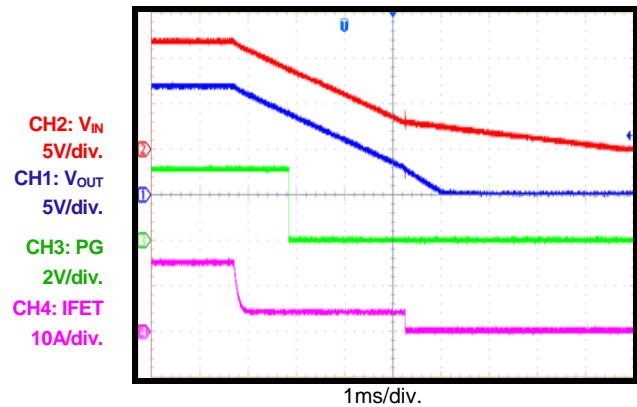
Shutdown through VIN

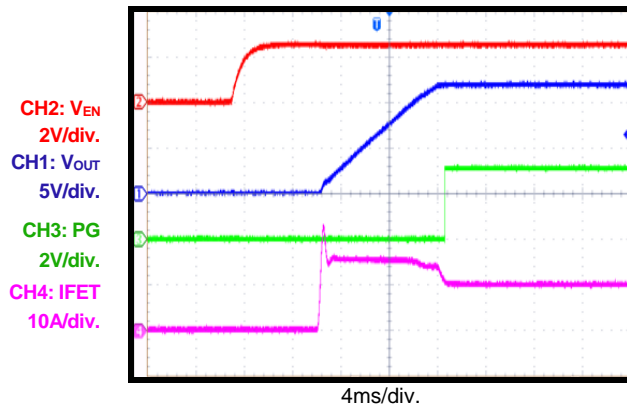
 I_{OUT} = 0A

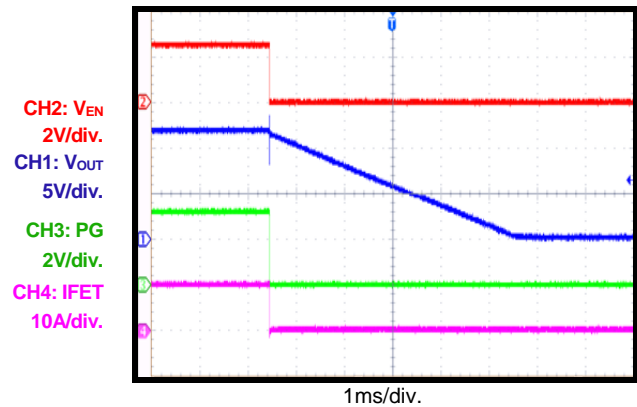
Shutdown through VIN

 I_{OUT} = 15A

Start-Up through EN

 I_{OUT} = 10A

Shut down through EN

 I_{OUT} = 10A

TYPICAL PERFORMANCE CHARACTERISTICS (continued)

 VIN = 12V, C_{OUT} = 4700μF, C_{SS} = 100nF, R_{MON} = 2kΩ T_A = +25°C, unless otherwise noted.

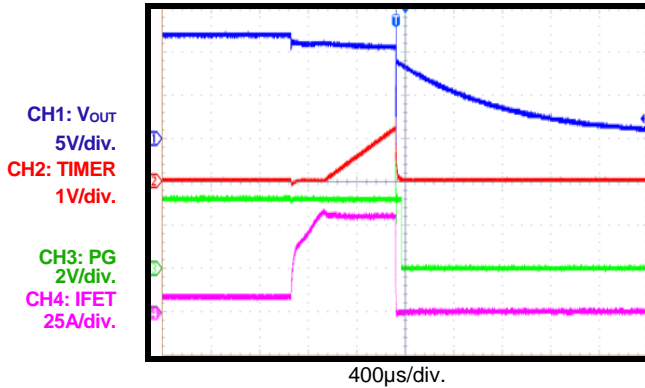
Latch OCP

 R_{ISET} = 12.1kΩ, I_{LIMIT} = 53.7A

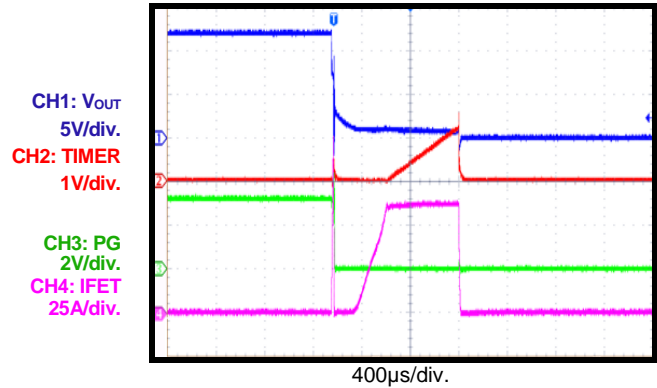
Latch SCP Entry

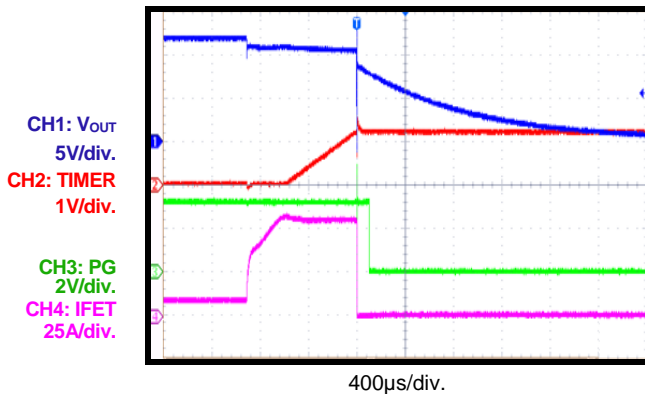
 R_{ISET} = 12.1kΩ, I_{LIMIT} = 53.7A

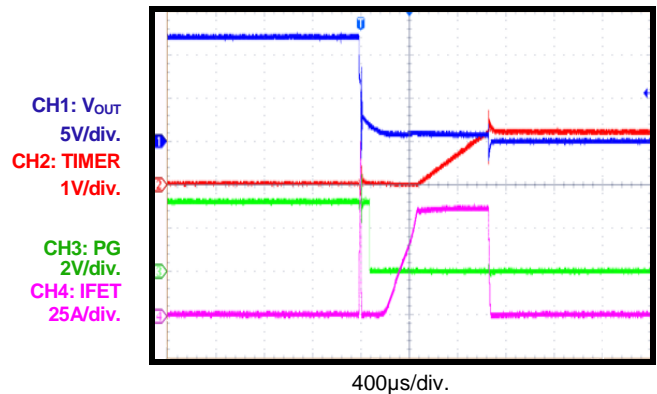
Auto-Retry, OCP

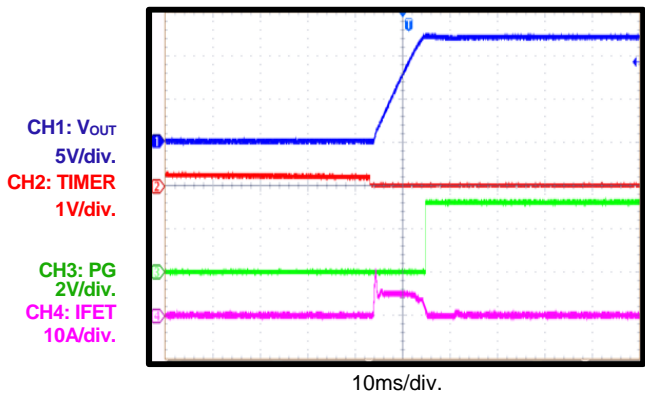
 R_{ISET} = 12.1kΩ, I_{LIMIT} = 53.7A

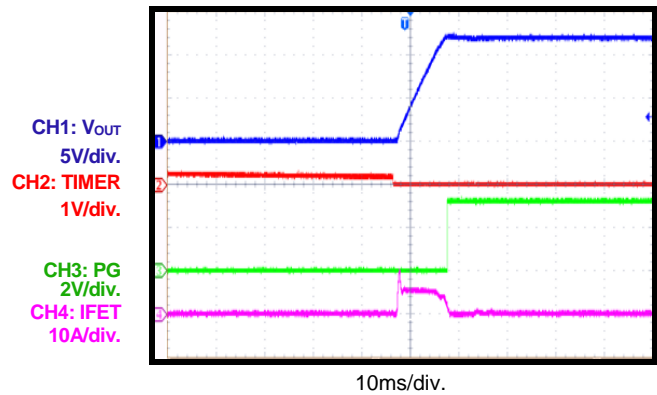
Auto-Retry, SCP Entry

 R_{ISET} = 12.1kΩ, I_{LIMIT} = 53.7A

Auto-Retry, OCP Recovery

 I_{OUT} = 0A

Auto-Retry, SCP Recovery

 I_{OUT} = 0A

TYPICAL PERFORMANCE CHARACTERISTICS (continued)

 VIN = 12V, C_{OUT} = 4700μF, C_{SS} = 100nF, R_{IMON} = 2kΩ, T_A = +25°C, unless otherwise noted.

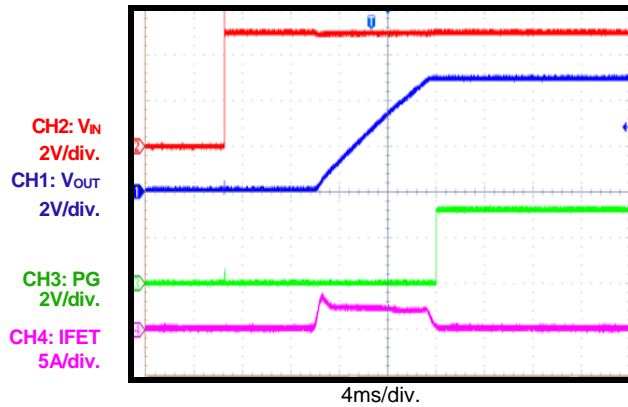
VIN Hot Plug

 I_{OUT} = 0A

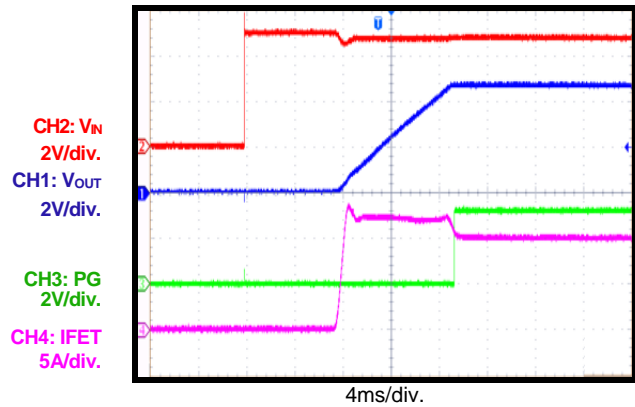
VIN Hot Plug

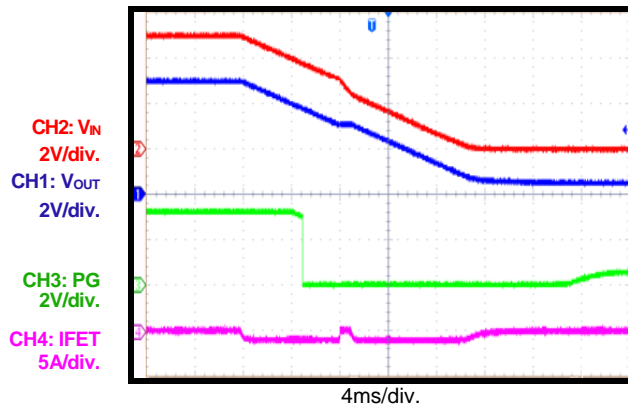
 I_{OUT} = 10A

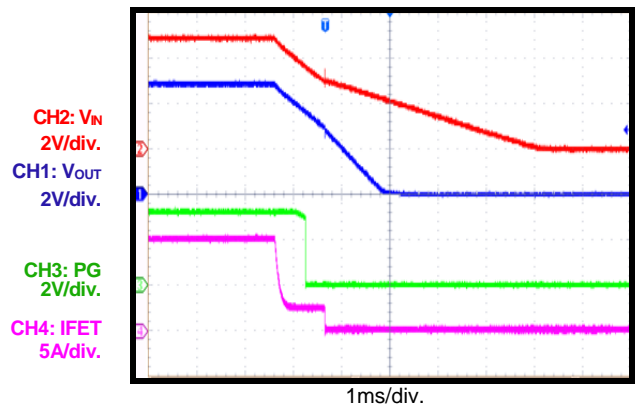
Shutdown through VIN

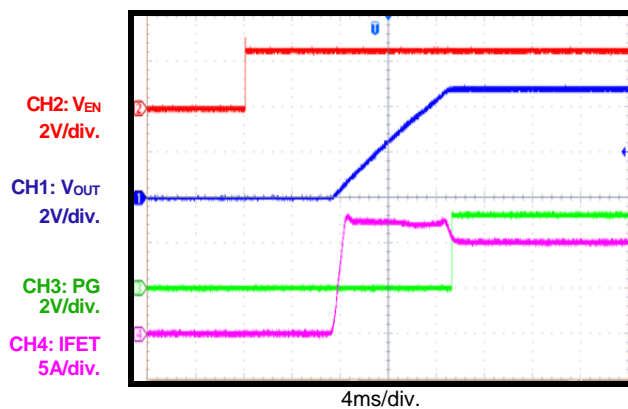
 I_{OUT} = 0A

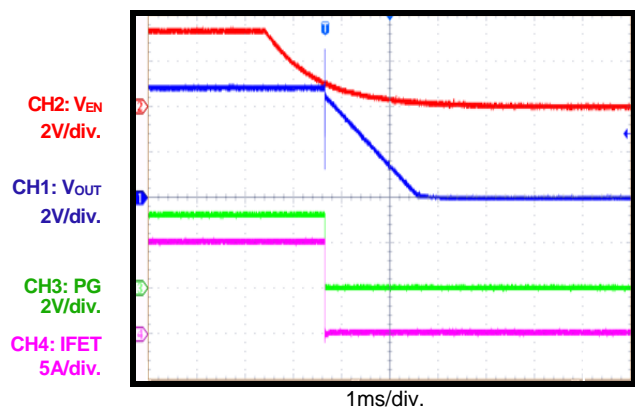
Shutdown through VIN

 I_{OUT} = 10A

Start-Up through EN

 I_{OUT} = 10A

Shutdown through EN

 I_{OUT} = 10A

PIN FUNCTIONS

Pin #	Name	Description
1-3, 16	VIN	Input power supply.
4, 13-15	OUT	Output voltage controlled by the IC. Place a Schottky diode between OUT and GND.
5	LOADEN	Load enable input. LOADEN is used with EN to control the MP5023 on/off function.
6	OV	Over-voltage enable input. Pull OV high to turn off the power MOSFET. An external resistor divider is used from the supply to OV to allow an internal comparator to detect whether the supply is above the OV limit.
7	PG	Power good. PG is an open-drain output. Pull PG up to a power supply through a 100kΩ resistor. When PG is high, power good is asserted. When PG is low, the output is outside of the UVLO/OV window. PG starts to work when the pull-up supply is established, even if VIN and EN are disabled.
8, 12	NC	No connection. Connect NC to ground.
9	IMON	Output current monitor. IMON provides a voltage proportional to the current flowing through the power device. Place a resistor (R_{IMON}) to ground to set the gain of the output.
10	TIMER	Timer set. An external capacitor sets the hot-plug insertion time delay, fault timeout period, and restart time.
11	SS	Soft start. An external capacitor connected to SS sets the soft-start time of the output voltage. The internal circuit controls the slew rate of the output voltage during turn-on. Float SS to set the soft-start time at its minimum of 1ms.
17	SCL	PMBus™ serial clock.
18	SDA	PMBus™ serial data.
19	ALERT#	PMBus™ alert. ALERT# is an open-drain output, active low.
20	GND	Ground.
21	VCC	Internal 3.3V LDO output. The control circuits are powered by this voltage. Decouple VCC with a minimum 1μF ceramic capacitor as close to VCC as possible in the event VIN collapses during a strong short from OUT to GND.
22	ISET	Current limit set. Place a resistor from ISET to ground to set the value of the current limit.
23	ADDR	PMBus™ slave address setting. Connect a resistor from ADDR to AGND to set the address of the MP5023.
24	EN	Enable. EN is a digital input that turns the chip on or off. Drive EN high to turn on the MP5023. Drive EN low to turn off the MP5023. Connect EN to VIN through a resistive voltage divider for automatic start-up. Do not float EN.

BLOCK DIAGRAM

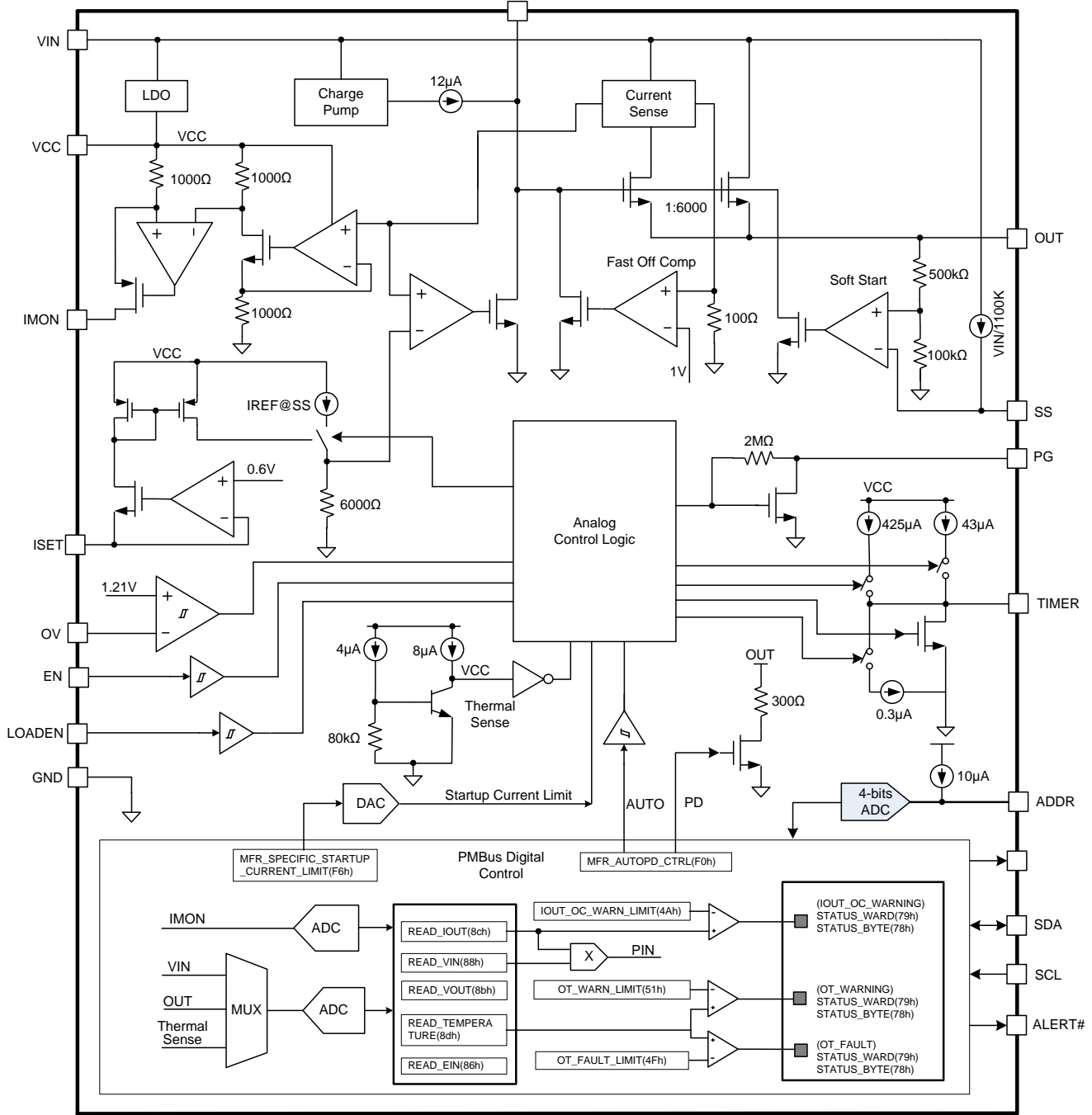

Figure 1: Functional Block Diagram

OPERATION

The MP5023 is designed to limit the inrush current to the load when a circuit card is inserted into a live backplane power source, thereby limiting the backplane's voltage drop and the dV/dt of the voltage to the load. The MP5023 provides an integrated solution to monitor the input voltage, output voltage, output current, and die temperature to eliminate the need for an external current sense power resistor, power MOSFET, and thermal sense device.

Current Limit

The MP5023 provides a constant current limit that can be programmed by an external resistor. Once the device reaches its current limit threshold, the internal circuit regulates the gate voltage to hold the current in the power MOSFET constant. To limit the current, the gate-to-source voltage must be regulated from 3.3V to around 1V. The typical response time is about 20 μ s, and the output current may have a small overshoot during this time period.

When the current limit is triggered, the fault timer starts. If the output current falls below the current limit threshold before the end of the fault timeout period, the MP5023 resumes normal operation. Otherwise, if the current limit duration exceeds the fault timeout period, the power MOSFET turns off. The subsequent behavior is related to the PMBus™ register configuration. If the temperature reaches the thermal protection threshold during the fault timeout period, the power MOSFET turns off.

When the AUTO bit in the PMBus™ register MFR_CTRL (F0h) is set to 1, the MP5023 functions in auto-retry mode for over-current protection (OCP). When the AUTO bit is set to 0, the latch-off mode is set once it detects an over-current condition and the duration exceeds the present value.

When the device reaches either its current limit or its over-temperature threshold, ALERT# is driven low to indicate a fault. The desired current limit at normal operation is a function of the external current limit resistor. The MP5023 current limit value should be higher than the normal maximum load current, allowing for tolerances in the current sense value.

Short-Circuit Protection (SCP)

If the load current increases rapidly due to a short circuit, the current may exceed the current-limit threshold greatly before the control loop can respond. If the current reaches a secondary current limit level, a fast turn-off circuit activates to turn off the power MOSFET using a 100mA pull-down gate discharge current (see Figure 2). This limits the peak current through the switch to limit the input voltage drop. The total short-circuit response time is about 200ns.

After V_{GS} drops low, the MP5023 attempts to start up again more rapidly to avoid an input voltage line transient issue. The gate to source is charged up by an internal charge pump. When V_{GS} rises above its threshold (V_{GS_TH}), the MP5023 is turned on. If the short circuit still remains, the load current is limited by the normal ISET current limit. The fault timer ramps to 1.21V if the fault is not removed, and then the MP5023 power MOSFET is turned off (see Figure 2).

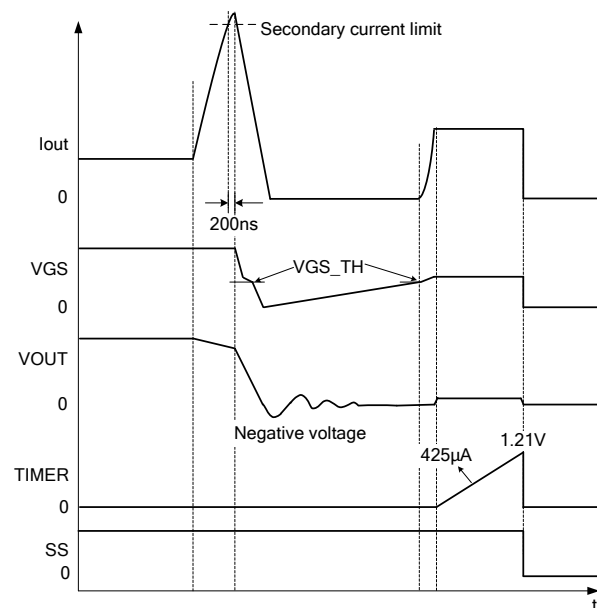

Figure 2: SCP in Latch-Off Mode

When a hard short occurs, if the input voltage is pulled below VCC quickly, the power MOSFET gate voltage is pulled low immediately regardless of whether the secondary current limit has been reached or not. The power MOSFET then retries once more with the same short-circuit condition present (see Figure 2).

After the MOSFET switches off, if the AUTO bit in register MFR_CTRL (F0h) is set to 0, the MP5023 latches off. If the AUTO bit is set to 1, the MP5023 restarts. During the restart process, if the short still remains, the MP5023 regulates the gate voltage to hold the current at the set current limit level.

If the retry once function is not needed when a short circuit occurs, connect PG to LOADEN to disable the retry start-up. Once PG is connected to LOADEN, the MP5023 works in latch-off mode.

Fault Timer and Restart

When the current reaches its limit threshold, a 425μA fault timer current source charges the external capacitor (C_{TIMER}) at TIMER. If the current limit state ceases before TIMER reaches 1.21V, the MP5023 returns to normal operation mode and releases the timer immediately when the current limit is removed. If the current limit state lasts after the TIMER voltage reaches 1.21V, the power MOSFET switches off. The subsequent restart procedure depends on the selected retry configuration: auto-retry mode or latch-off mode.

If the AUTO bit in MFR_CTRL (F0h) is set to 1, the MP5023 operates in auto-retry mode (see Figure 3). At the end of the fault timeout period, the power switch turns off, and a low current sink of 0.3μA discharges the external capacitor (C_{TIMER}). When the TIMER voltage reaches the low threshold (0.2V), the voltage is first discharged to zero from 0.2V before the MP5023 restarts. If the fault condition remains, the fault timeout period and restart timer repeat.

If the AUTO bit in MFR_CTRL (F0h) is set to 0, the MP5023 operates in latch-off mode (see Figure 4). Restart the input power or cycle the EN signal to resume function. When a fault occurs, there is about eight seconds of reinsertion blanking time for EN to restart. After the MP5023 detects a fault, if EN goes high during this blanking time, the switch will not turn on. At the end of the blanking time, recycle EN to turn on the switch, and EN behaves as normal.

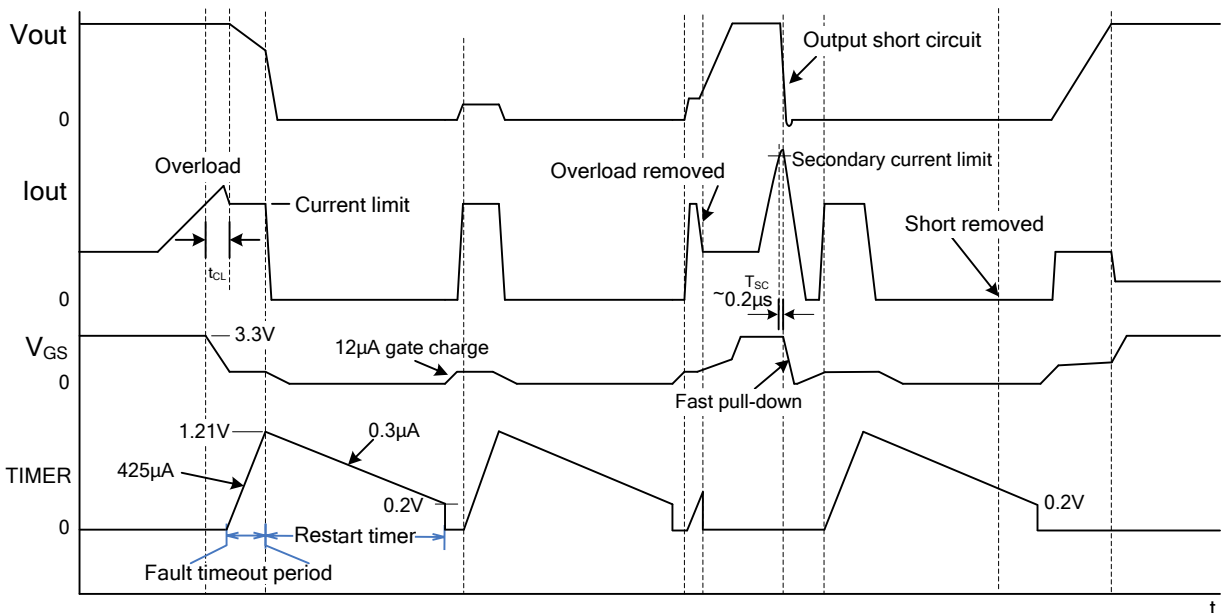

Figure 3: Over-Current Protection (Auto-Retry Mode, F0h AUTO bit = 1)

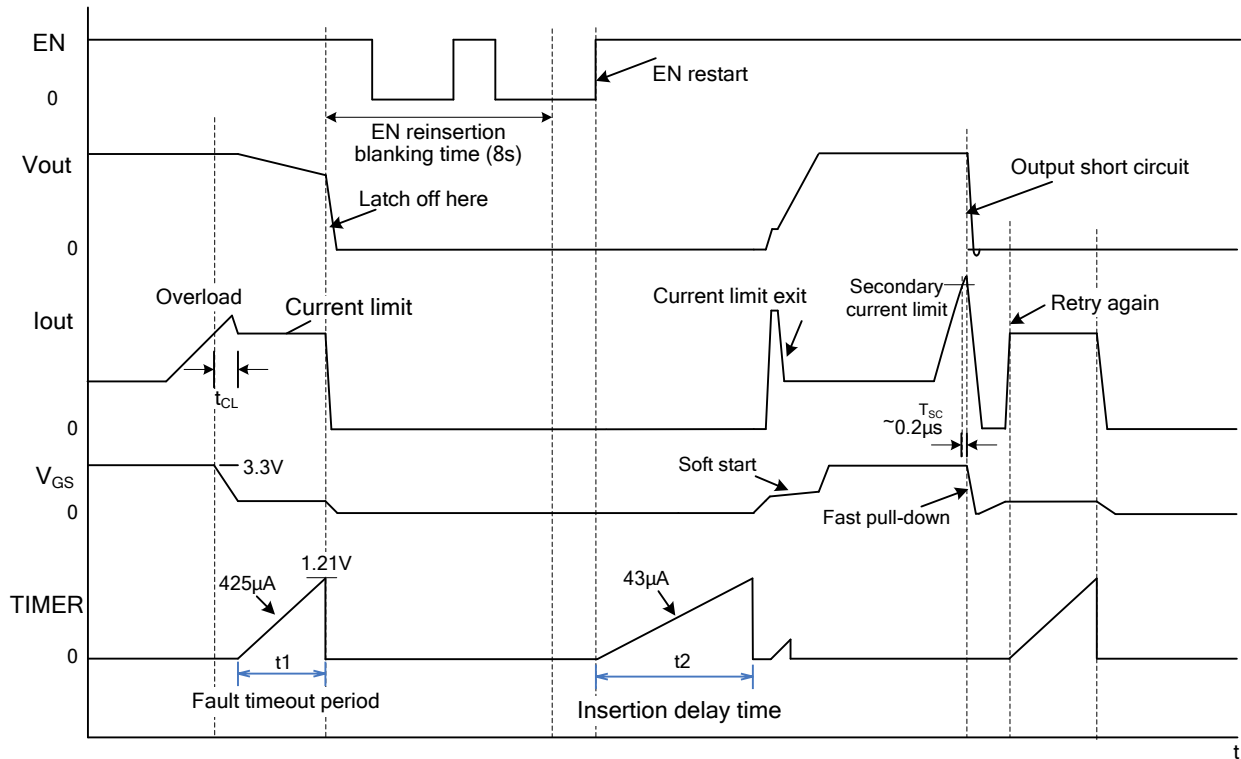

Figure 4: Over-Current Protection (Latch-Off Mode, F0h AUTO bit = 0)

Input and Output Transient Protection

Hot-swap systems experience positive transients on the input during a hot plug or rapid turn-off with high currents due to parasitic inductance in the input circuit.

For input transient protection, a transient voltage suppressor (TVS) diode, a type of Zener diode, is required on the input to limit transient voltages below the absolute maximum ratings.

The output may experience negative transients during rapid turn-off with high currents due to parasitic inductance in the output circuit. If a transient makes OUT more negative, the power MOSFET cannot be turned off.

An output voltage clamp diode is required on the output to limit negative transients. Select a Schottky diode with a low forward voltage.

Power Good (PG)

The power good (PG) indicates whether the output voltage is in the normal range relative to the input voltage. PG is the open drain of a MOSFET. Pull PG up to VCC through a 100kΩ resistor. During power-up, the power good output is driven low. This indicates to the

system to remain off and minimizes the load on OUT to reduce inrush current and power dissipation at start-up.

The PG signal is pulled high when $V_{GS} > 2V$, $V_{OUT} > V_{IN} - 0.5V$, $V_{OUT} > 90\%V_{IN}$, and V_{OUT} reaches the POWER_GOOD_ON (5Eh) register value (default set to 90% of V_{OUT}). The system can now draw full power.

When V_{OUT} is lower than the POWER_GOOD_OFF (5Fh) register value (default set to 75% of V_{OUT}), PG is switched low.

The PG output is pulled low when either EN is below its threshold or the input UVLO/OV is triggered.

PG needs a power supply to pull up. PG can be connected to the MP5023's VCC output supply. Use a 100kΩ pull-up resistor for PG.

Power-Up Sequence

For hot-swap applications, the input of the MP5023 can experience a voltage spike or transient during the hot-plug procedure. This is caused by the parasitic inductance of the input trace and the input capacitor. An insertion delay determined by the external capacitor at TIMER stabilizes the input voltage.

When EN is high, the input voltage rises immediately, and the internal V_{GS} of the power MOSFET is pulled low by a 30Ω resistor (see Figure 5). GATE is always pulled low when VIN is plugged in with a high dV/dt.

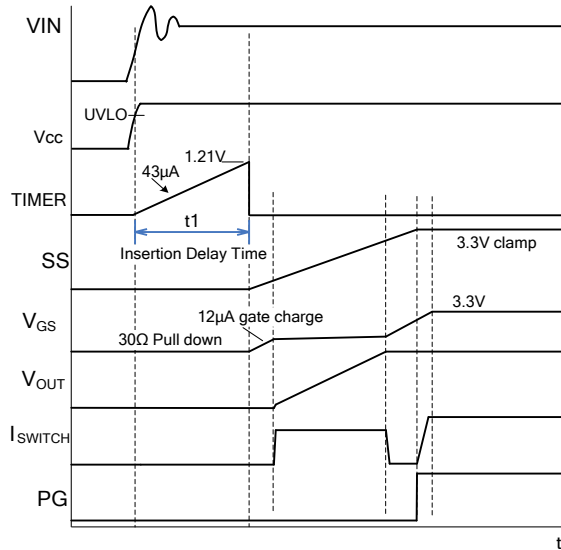

Figure 5: Start-Up Sequence

TIMER is charged through a $43\mu\text{A}$ constant current source when the input voltage reaches the UVLO threshold. When the TIMER voltage reaches 1.21V , a $12\mu\text{A}$ current source pulls up the power MOSFET's gate-source voltage. Meanwhile, the TIMER voltage drops. Once the GATE voltage reaches its threshold (V_{GS_TH}), the output voltage rises. The output voltage rises following the SS controlled slew rate, and the rise time is determined by the soft-start capacitor.

Soft Start (SS)

A capacitor connected to SS determines the soft-start time. When the insertion delay time ends, a constant current source proportional to the input voltage ramps up the SS voltage. The output voltage rises at a similar slew rate to the SS voltage.

The SS capacitor value can be calculated with Equation (1):

$$C_{SS} = \frac{t_{SS}}{R_{SS}} \quad (1)$$

Where t_{SS} is the soft start time, and R_{SS} is $100\text{K}\Omega$. For example, a 100nF capacitor produces a soft-start time of 10ms .

If the load capacitance is extremely large, the current required to maintain the pre-set soft-start time exceeds the current limit. In this case, the rise time is controlled by the load capacitor and the current limit.

Float SS to generate a fast ramp-up voltage. A $12\mu\text{A}$ current source pulls up the gate of the power MOSFET. The gate charge current controls the output voltage rise time. The approximate soft-start time is 1ms , which is the minimum soft-start time.

Soft-Start Current Limit Adjust Function

During soft start, the current limit value is programmed by the user-defined register `MFR_SPECIFIC_STARTUP_CURRENT_LIMIT (F6h)`. The current limit can be set high or low during the soft start (see Figure 6).

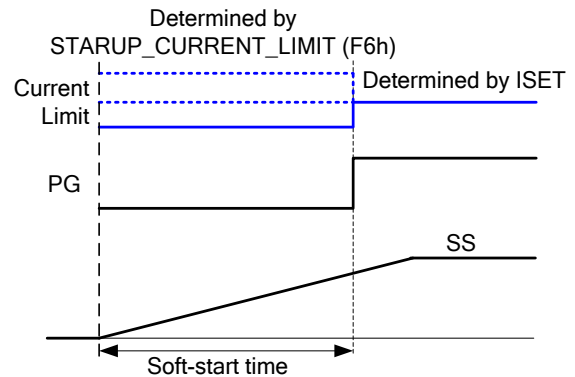

Figure 6: Start-Up Current Limit Set

The adjustable soft-start current limit benefits the start-up with different output capacitors and different soft-start times. The start-up current limit is only active while PG is low.

The start-up current limit can be disabled by the `MFR_CTRL (F0h)` register bit `ISTART_EN`. In a normal operating state, the current limit is determined by the ISET resistor.

Enable (EN) and LOADEN

EN and LOADEN are used to control the on/off function of the MP5023 (see Table 1).

Table 1: Output Enable Table

LOAD Enable Blanking Time is Over?	EN	LOADEN	Status
N	0	0	OFF
N	0	1	OFF
N	1	0	ON
N	1	1	ON
Y	0	0	OFF
Y	0	1	OFF
Y	1	0	OFF
Y	1	1	ON

After VIN power on, EN stepping from 0 to 1 initiates LOADEN blanking time. During LOADEN blanking time, LOADEN status is blanked and EN = 1 alone is sufficient to turn on the power switch. After the LOADEN blanking time expires, both EN = 1 and LOADEN = 1 are required to keep the power switch on.

After LOADEN blanking time expires, if EN=1, LOADEN=0, the MP5023 power switch will be

turned off. At Auto-Retry mode, the power switch can be turned on by any of VIN recycle, EN recycle or PMBus OPERATION command on (see Figure 7 (b)). At Latch-Off mode, the power switch can be turned on again with any of the following 3 methods:

1. Recycle VIN, the MP5023 can be turned on again.
2. After a typical of 8s reinsertion blanking time, recycle EN signal can turn on the power switch again (see Figure 7 (a)).
3. After a typical of 8s reinsertion blanking time, a PMBus OPERATION on command can turn on the power FET again.

At all times, EN = 0 alone turns off the power switch.

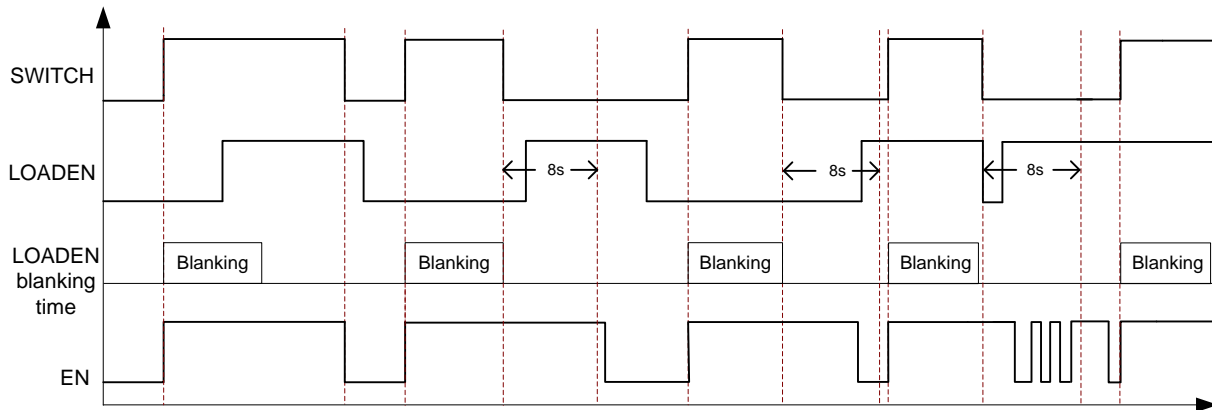
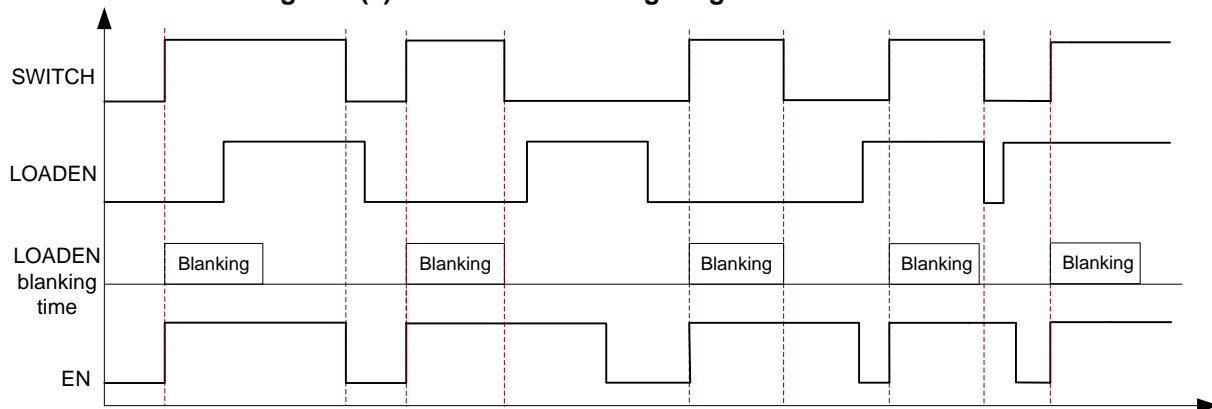
Figure 7(a): EN/LOADEN Timing Diagram at Latch-Off mode

Figure 7(b): EN/LOADEN Timing Diagram at Auto-Retry mode

For automatic start-up, EN can be pulled up to the input voltage through a resistive voltage divider. Choose the values of the pull-up resistor (R_{up} from VIN to EN) and the pull-down resistor (R_{down} from EN to GND) to determine the automatic start-up voltage from Equation (2):

$$V_{IN-START} = 1.21 \times \frac{(R_{up} + R_{down})}{R_{down}} (V) \quad (2)$$

For example, for $R_{up} = 453k\Omega$ and $R_{down} = 100k\Omega$, $V_{IN-START}$ is 6.7V.

To avoid noise, a 10nF ceramic capacitor from EN to GND is recommended.

The MP5023 can turn the hot swap on or off using commands over the PMBus™ interface. The output may also be enabled or disabled by writing 80h or 00h to the OPERATION (01h) register. To re-enable the output after a fault, the fault condition should be cleared and the OPERATION (01h) register should be written to 00h and then 80h. See the PMBus™ Commands section on page 32 for details.

LOADEN Blanking Time

Suppose EN is high. LOADEN has a fixed blanking time of up to eight seconds, which is programmed by the digital register that prevents LOADEN from de-asserting during the blanking time. All fault functionality is operative during start-up, so the power switch shuts down if a fault is detected. However, LOADEN going low during this blanking time will not turn off the switch. At the end of the blanking time, LOADEN behaves as normal.

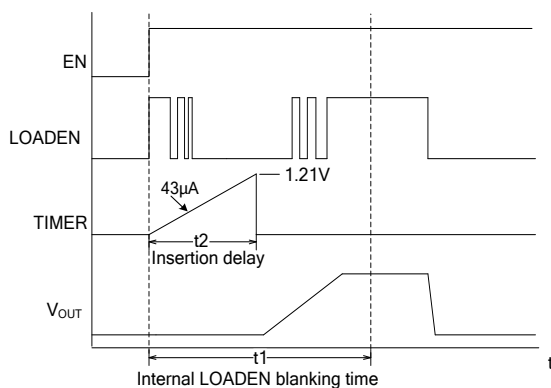

Figure 8: LOADEN Blanking Time

Damaged MOSFET Detection

After VCC is higher than the UVLO rising threshold voltage, the MP5023 can detect a

shorted pass MOSFET during power-up by treating an output voltage that exceeds $V_{IN} - 0.5V$ during power-up as a short on the power MOSFET.

The BAD_FET_HEALTH bit (bit[0] of the high byte) of the STATUS_WORD (79h) register is toggled high, ALERT# is pulled low to indicate a fault condition, and the power switch is held off. Once $V_{OUT} \leq V_{IN} - 0.5V$, the MP5023 starts up normally, and the MOSFET short bit is cleared to 0.

After SS finishes ramping, if V_{GS} is pulled low and no other fault occurs, an internal 250ms timer is initiated, and then the GATE voltage reaches $V_{GS} > 2V$. If V_{GS} is detected to be less than 2V after the 250ms timer ends, the BAD_FET_HEALTH bit (bit[0] of the high byte) of the STATUS_WORD (79h) register is toggled high, ALERT# is pulled low to indicate a fault condition, and the power switch is held off. Recycle VIN or EN to restart the MP5023.

VCC UVLO

The MP5023 has VCC under-voltage lockout (UVLO) protection. When VCC is higher than the UVLO rising threshold voltage, the MP5023 is powered up. The MP5023 shuts off when VCC is lower than the UVLO falling threshold voltage. This is a non-latch protection. The MP5023 is disabled when VCC falls below 2.4V.

VIN Over-Voltage Protection (OVP)

The MP5023 enables the output (see Table 2). The devices are ready to drive the output when the VCC supply rises above the UVLO threshold.

Table 2: Output Enable Table

Power Supply (VCC)	Precision Analog Input (V_{OV})	OUT
$VCC > UVLO$	$V_{OV} < V_{OV_TH}$	ON
$VCC < UVLO$	X ⁽⁶⁾	OFF
X ⁽⁶⁾	$V_{OV} > V_{OV_TH}$	OFF

NOTE:

6) The value of "X" does not matter.

The device turns on the output when VCC is higher than UVLO, EN is high ($>1.21V$), and V_{OV} is low ($<1.21V$). The MP5023 turns off the output when EN falls below $1.21V - V_{EN_HYS}$, or V_{OV} rises above 1.21V. Once the voltage on OV exceeds 1.21V, the power MOSFET is shut

down, the output is disabled and PG goes low. When the OV voltage falls below $1.21V - V_{OV_HYS}$, the device operation is determined by the AUTO_OV bit of the MFR_CTRL (F0h) register. If AUTO_OV is set to 0, the device is latched off, and VIN or EN must be recycled to restart the MP5023. If the bit is set to 1, the MP5023 goes into auto-retry mode, the output is enabled, and the PG line is released.

Auto-Retry or Latch-Off through PMBus™

When the AUTO bit in the PMBus™ register MFR_CTRL (F0h) is set to 1, the MP5023 is in auto-retry mode. In this mode, the MP5023 turns off when it exceeds its thermal limit or the current limit times out. The MP5023 turns back on when it cools by 20°C or the restart timer completes.

When the AUTO bit is set to 0, the MP5023 is in latched fault mode. In latched fault mode, a thermal fault or current limit fault latches the output off until the enable line is toggled from low to high or the input voltage restarts.

Output Discharge through PMBus™

When the PD bit in the MFR_CTRL (F0h) register is set to 1, the MP5023 works in pull-down mode. In this mode, when the power MOSFET is turned off, an integrated 300Ω pull-down resistor attached to the output discharges the output after a 4ms delay when EN or LOADEN is low.

If the PD bit is set to 0, pull-down mode and the PD delay timer are disabled. The output voltage discharges through the external load.

Monitoring the Output Current

IMON provides a voltage proportional to the output current (the current through the power device). Place a 100nF capacitor from IMON to GND to smooth the indicator voltage.

Generally, place a 2kΩ resistor (R_{IMON}) to ground to set the gain of the output, which is about 20mV per ampere. For the best accuracy, use resistors within 1%.

IMON Scaling

The MP5023 contains a user-programmable scale factor and a programmable current offset (IOUT_CAL_GAIN and IOUT_CAL_OFFSET). The programmable parameters allow users to

match the IMON scaling, providing the most accurate current reporting across the entire load range.

The IOUT_CAL_GAIN command is used to set the IOUT calculation gain when different IMON resistors are used. The current is proportional to the real analog value. The maximum GAIN can be set to 51.1mΩ. If a smaller IMON resistor is used, the GAIN value decreases as well. The default IOUT_CAL_GAIN is set to 00C8h when a 2kΩ R_{IMON} is used. The real current can be calculated with Equation (3):

$$READ_IOUT = \left(\frac{V_{IMON}}{IOUT_CAL_GAIN} \right) + IOUT_CAL_OFFSET \quad (3)$$

Although IMON has no bias value as the load current, IOUT_CAL_OFFSET is still needed for the quantization error between IOUT_CAL_GAIN and the analog value.

Thermal Protection

The MP5023 employs thermal shutdown by monitoring the junction temperature of the IC internally. If the junction temperature exceeds the thermal warning threshold, which is decided by the PMBus™ register OT_WARN_LIMIT (51h), the OT_FAULT_WARN bit in the STATUS BYTE register is set. When the warning level is passed, the system manager is notified to take action. If the system does not take action, the junction temperature continues rising until it exceeds the thermal shutdown threshold (145°C, typically determined by analog, or can be set by OT_FAULT_LIMIT (4Fh) register). If the OT_FAULT_LIMIT value is set to be higher than 145°C, the register value is neglected, and the MP5023 enters analog thermal shutdown when the junction temperature reaches 145°C.

After thermal shutdown, the MP5023's operation mode depends on the AUTO bit in MFR_CTRL (F0h). If thermal auto-retry mode is selected, the analog thermal recovery hysteresis is 20°C.

When the MP5023 works in latch-off mode, if the measured temperature falls below the value in the OT_FAULT_LIMIT register, the power MOSFET may be switched back on with the OPERATION command.

APPLICATION INFORMATION

Current Limit Set (R_{ISET})

The MP5023 current limit value should be higher than the normal maximum load current, allowing for tolerances in the current sense value. The current limit can be set with Equation (4):

$$I_{LIMIT} = \frac{0.65}{R_{ISET}} \times 10^6 (A) \quad (4)$$

Where R_{ISET} is the resistor connected from ISET to ground (in Ω).

VIN OVP Set

An external resistive divider from VIN to OV provides the flexibility to set the over-voltage lockout threshold. Place a 10nF capacitor from OV to ground to smooth the indicator voltage. When the voltage on OV exceeds 1.21V, the gate of the MOSFET is pulled low. The output is disabled, and PG goes low.

Maximum Continuous Output Current

The MP5023 drives up to 40A of continuous current per device at room temperature and no air flow. With air flow, the maximum continuous output current can reach up to 50A. See Figure 9 for the derating curve of the case temperature rise vs. the output current at different air conditions.

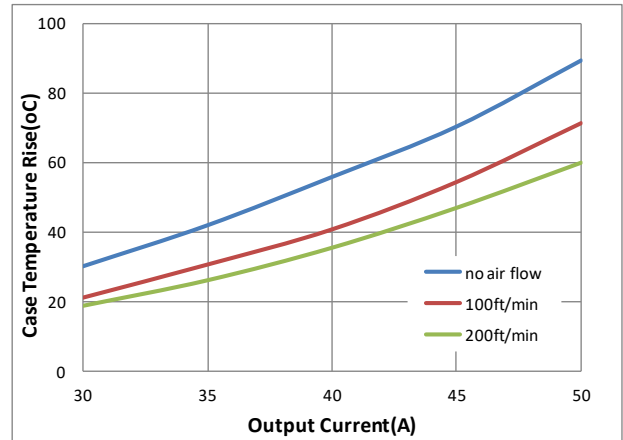

Figure 9: IOUT_MAX Derating Curve

Design Example

The detailed application schematic is shown in Figure 10 through Figure 13. Figure 10 shows the application circuit for applications where the over-current limit is higher. Figure 11 shows the application circuit for applications where the over-current limit is lower. Figure 12 shows the application circuit for applications with latch-off mode with only LOADEN connected to PG. Figure 13 shows the application circuit for applications with a 5V supply. The typical performance and waveforms are shown in the Typical Performance Characteristics section. For more detail device applications, please refer to the related evaluation board datasheet and application note.

TYPICAL APPLICATION CIRCUITS

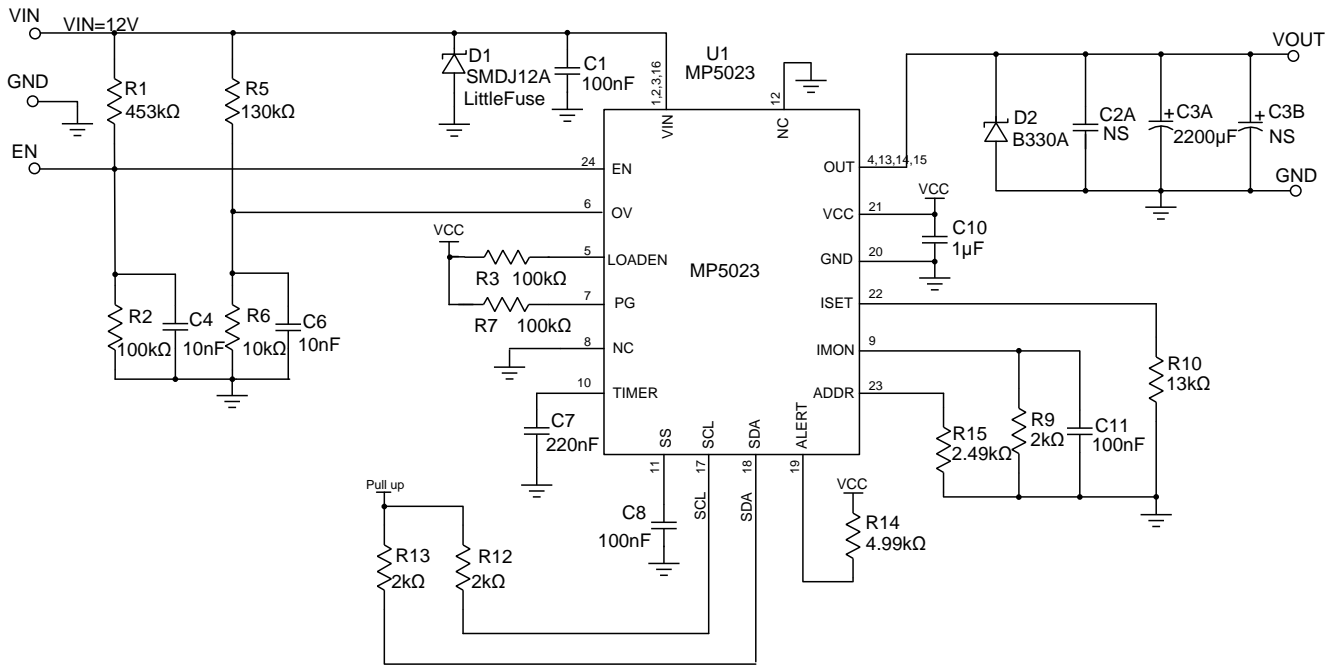

Figure 10: Typical Application Circuit for High Current Limit ($I_{LIMIT} = 50A$)

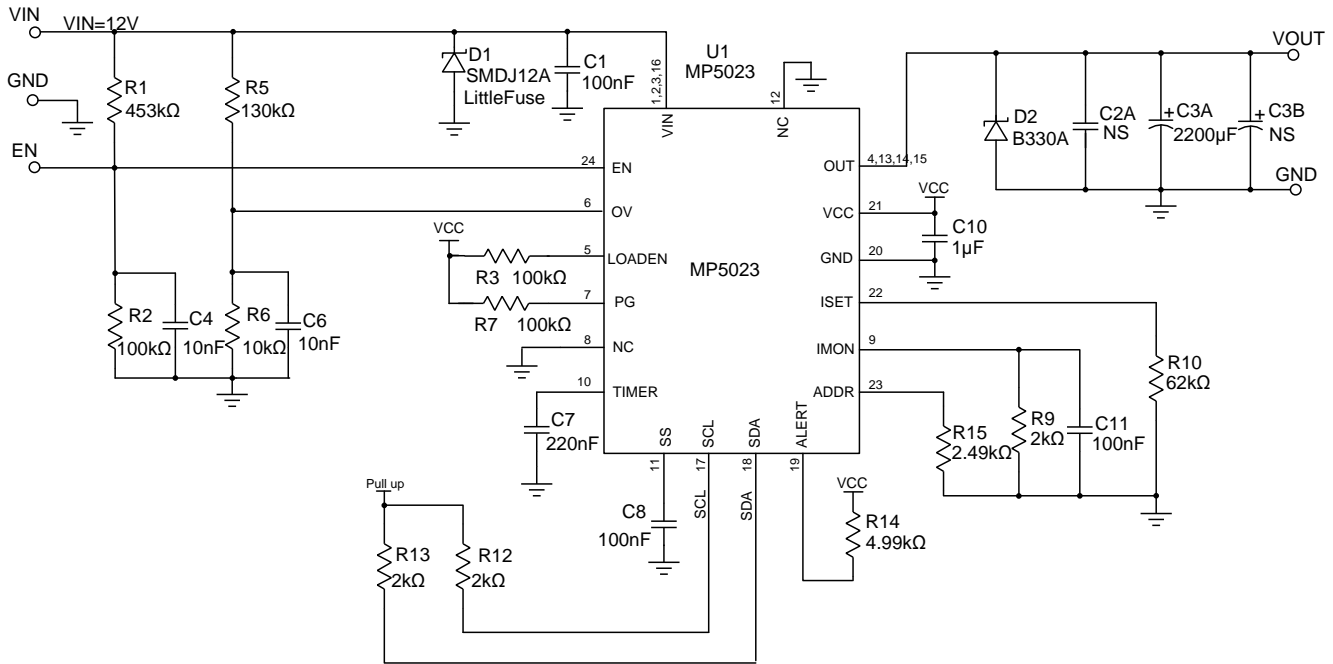

Figure 11: Typical Application Circuit for Low Current Limit ($I_{LIMIT} = 10A$)

TYPICAL APPLICATION CIRCUITS *(continued)*

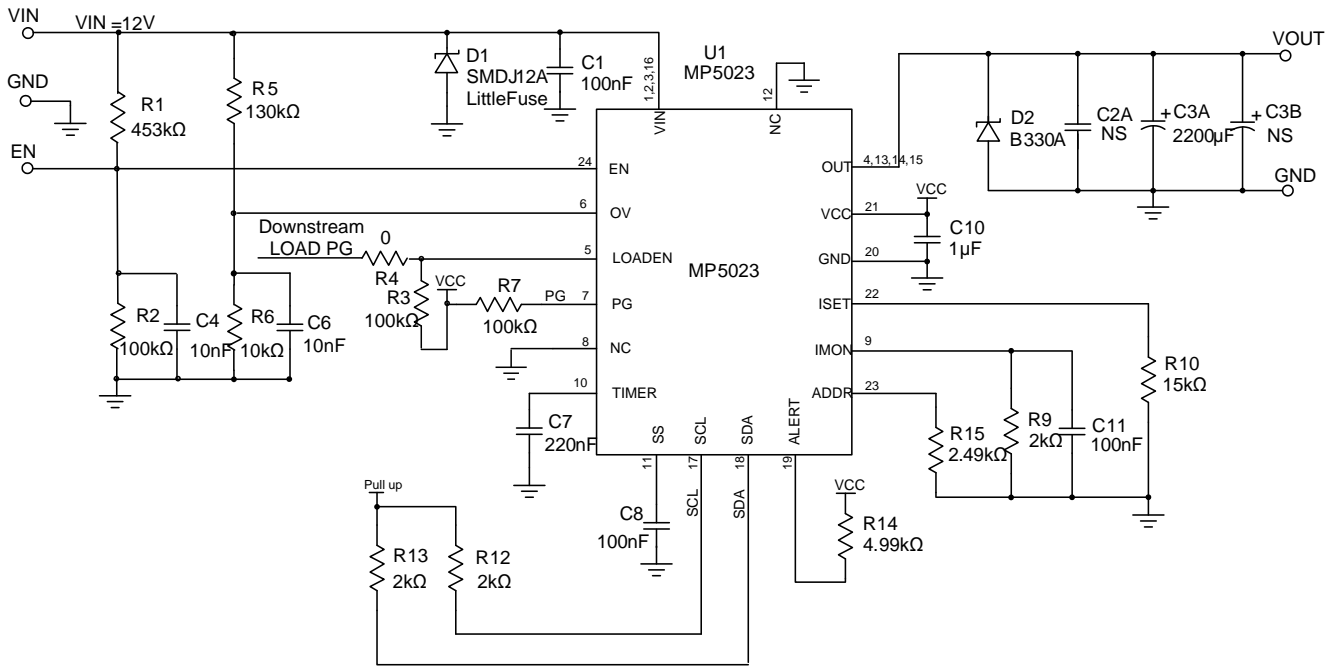

Figure 12: Typical Application Circuit for LOADEN connect to Downstream Load PG

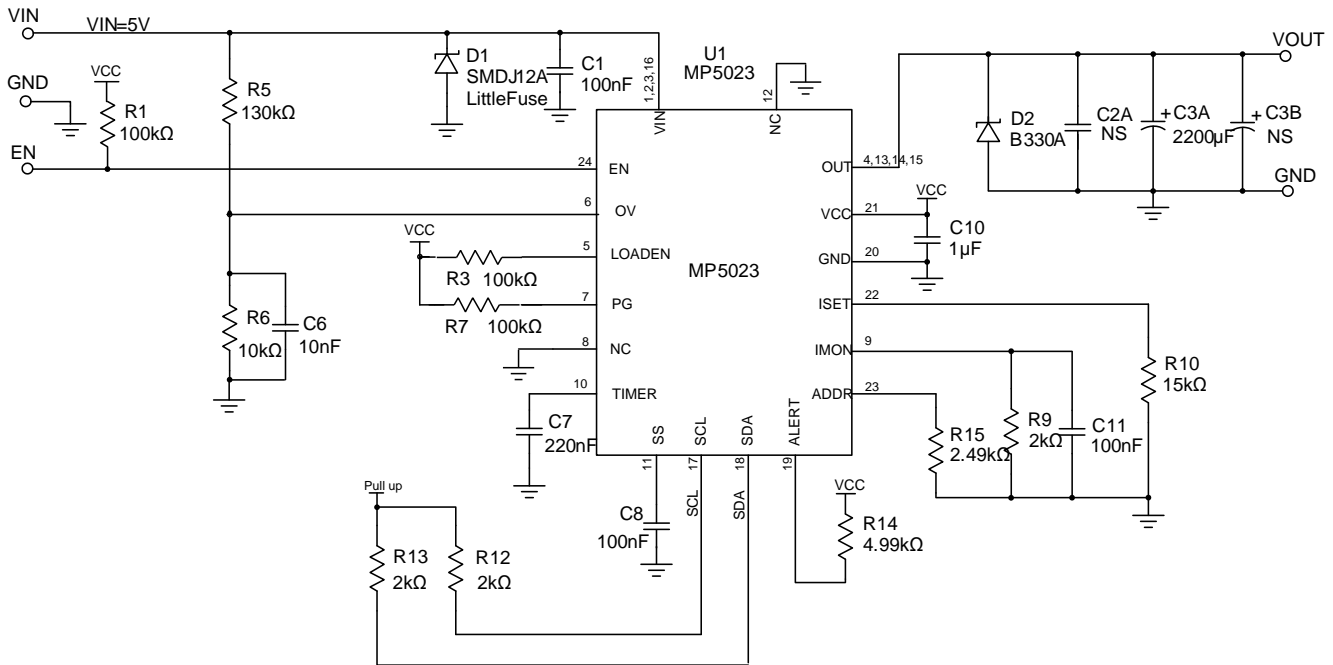

Figure 13: Typical Application Circuit for 5V Supply

PCB Layout Guidelines

Efficient PCB layout is critical for stable operation. A four-layer layout is strongly recommended to achieve better thermal performance. For best results, refer to Figure 13 and follow the guidelines below.

- 1) Place the MP5023 close to the board's input connector to minimize the trace inductance.
- 2) Place a 1μF capacitor as close to VCC as possible.
- 3) Place a TVS diode close to VIN and GND to minimize transients, which may occur on the input supply line.

Transients of several volts can occur easily when the load current is shut off.

- 4) Place a Schottky diode close to OUT and GND to minimize the OUT negative voltage.
- 5) Keep the high current path from the board's input to the load and the return path parallel and close to each other to minimize loop inductance.
- 6) Connect an analog signal ground AGND plane to the PCB power ground planes at a single point local to the MP5023.

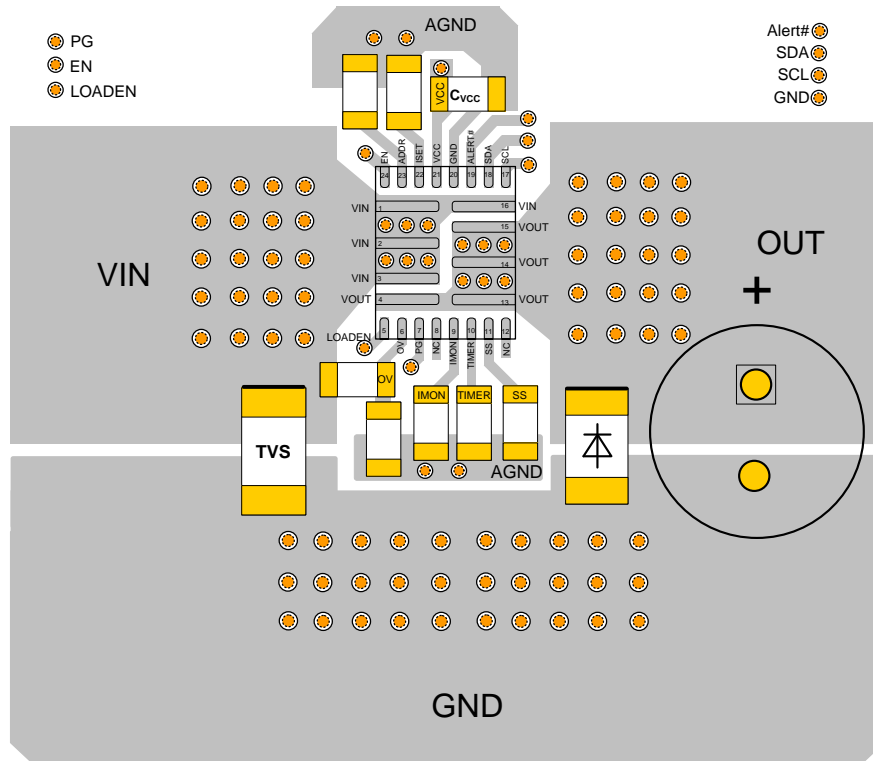

Figure 13: Recommended Layout
VIN TVS: SMDJ12A
OUT Diode: MBRA340T3G or B330A for Single MP5023

PMBUS™ INTERFACE

PMBus™ Serial Interface Description

The system management bus (PMBus™) is a two-wire, bidirectional, serial interface consisting of a data line (SDA) and a clock line (SCL). The lines are pulled to a bus voltage externally when they are idle. When connected to the line, a master device generates the SCL signal and device address and arranges the communication sequence. This is based on the principles of I²C operation. The MP5023 interface is a PMBus™ slave, which supports different possible maximum bus speeds (100kHz, 400kHz, and 1MHz). The PMBus™ interface adds flexibility to the power supply solution.

Slave Address

To support multiple MP5023 devices used on the same PMBus™, use ADDR to program the slave address for the MP5023. There is a 20μA current flowing out of ADDR. Connect a resistor between ADDR and AGND to set the ADDR voltage. The internal ADC converts the ADDR voltage to set the PMBus™ address. A maximum of eight addresses can be set by ADDR. The MFR_ADDR_PMBUS (F1h) register can be used to set the PMBus™ address digitally.

After the address is selected, the device has a unique address during normal operation.

Table 3 shows the PMBus™ address for different resistor values from ADDR to AGND.

Table 3: Slave Address vs. ADDR Resistor

No.	R _{ADDR}	Slave Address
1	2.49kΩ	40h
2	7.5kΩ	41h
3	12.4kΩ	42h
4	17.4kΩ	43h
5	24.9kΩ	44h
6	34.8kΩ	45h
7	47.5kΩ	46h
8	63.4kΩ	47h

Start and Stop Conditions

Start and stop are signaled by the master device, which signifies the beginning and the end of the PMBus™ transfer. The start condition is defined as the SDA signal transitioning from high to low while the SCL is high. The stop condition is defined as the SDA signal transitioning from low to high while the SCL is high (see Figure 14). The master then generates the SCL clocks and transmits the device address and the read/write direction bit (r/w) on the SDA line. Data is transferred in 8-bit bytes by the SDA line. Each byte of data is to be followed by an acknowledge bit.

PMBus™ Update Sequence

The MP5023 requires a start condition, a valid PMBus™ address, a register address byte, and a data byte for a single data update. The MP5023 acknowledges the receipt of each byte by pulling the SDA line low during the high period of a single clock pulse. A valid PMBus™ address selects the MP5023, and the MP5023 performs an update on the falling edge of the LSB byte.

Protocol Usage

All PMBus™ transactions on the MP5023 are done using defined bus protocols. The following protocols are implemented:

- Send byte with PEC
- Receive byte with PEC
- Write byte with PEC
- Read byte with PEC
- Write word with PEC
- Read word with PEC
- Block read with PEC

PMBus™ Message Format

In Figure 15, the unshaded cells indicate that the bus host is actively driving the bus. Shaded cells indicate that the MP5023 is driving the bus.

S = start condition

Sr = repeated start condition

P = stop condition

R = read bit

\bar{w} = write bit

A = acknowledge bit (0)

\bar{A} = acknowledge bit (1)

“A” represents the acknowledge (ACK) bit. The ACK bit is typically active low (logic 0) if the transmitted byte is received successfully by a device. However, when the receiving device is the bus master, the acknowledge bit for the last byte read is logic 1, indicated by \bar{A} .

Packet Error Checking (PEC)

The MP5023 PMBus™ interface supports the use of a packet error checking (PEC) byte. The PEC byte is transmitted by the MP5023 during a read transaction or sent by the bus host to the MP5023 during a write transaction.

The PEC byte is used by the bus host or the MP5023 to detect errors during a bus transaction, depending on whether the transaction is a read or a write. If the host determines that the PEC byte read during a read transaction is incorrect, it can decide to repeat the read if necessary. If the MP5023 determines that the PEC byte sent during a write transaction is incorrect, it ignores the command (it is not executed) and sets a status flag. Within a group command, the host can choose to send or not send a PEC byte as part of the message to the MP5023.

PMBus™ Alert Response Address (ARA)

The PMBus™ alert response address (ARA) is a special address that can be used by the bus host to locate any devices that need to talk to it. A host typically uses a hardware interrupt pin to monitor the PMBus™ ALERT# pins of a number of devices. When a host interrupt occurs, the host issues a message on the bus using the PMBus™ receive byte or receive byte **with PEC protocol**.

The special address used by the host is 0x0C. Any devices that have a SMBAlert signal return their own 7-bit address as the seven MSBs of the data byte. The LSB value is not used and can be either 1 or 0. The host reads the device address from the received data byte and proceeds to handle the alert condition.

More than one device may have an active SMBAlert signal and attempt to communicate with the host. In this case, the device with the lowest address dominates the bus and succeeds in transmitting its address to the host. The device that succeeds disables its PMBus™ alert signal. If the host sees that the PMBus™ alert signal is still low, it continues to read addresses until all devices that need to talk to it have transmitted their addresses successfully.

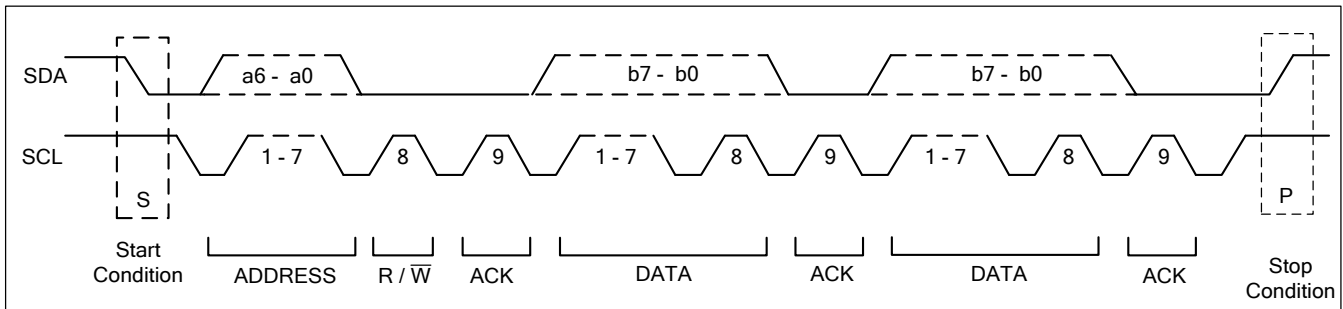

Figure 14: Data Transfer over PMBus™

Send Byte and Send Byte with PEC

1	7	1	1	8	1	1
S	Slave Address	Wr	A	Data Byte	A	P

1	7	1	1	8	1	8	1	1
S	Slave Address	Wr	A	Data Byte	A	PEC	A	P

Receive Byte and Receive Byte with PEC

1	7	1	1	8	1	1
S	Slave Address	Rd	A	Data Byte	A	P

1	7	1	1	8	1	8	1	1
S	Slave Address	Rd	A	Data Byte	A	PEC	A	P

Write Byte and Write Byte with PEC

1	7	1	1	8	1	8	1	1
S	Slave Address	Wr	A	Command Code	A	Data Byte	A	P

1	7	1	1	8	1	8	1	8	1	1
S	Slave Address	Wr	A	Command Code	A	Data Byte	A	PEC	A	P

Write Word and Write Word with PEC

1	7	1	1	8	1	8	1	8	1	1
S	Slave Address	Wr	A	Command Code	A	Data Byte Low	A	Data Byte High	A	P

1	7	1	1	8	1	8	1	8	1	8	1	1
S	Slave Address	Wr	A	Command Code	A	Data Byte Low	A	Data Byte High	A	PEC	A	P

Read Byte and Read Byte with PEC

1	7	1	1	8	1	1	7	1	1	8	1	1
S	Slave Address	Wr	A	Command Code	A	S	Slave Address	Rd	A	Data Byte	A	P

1	7	1	1	8	1	1	7	1	1	8	1	8	1	1
S	Slave Address	Wr	A	Command Code	A	S	Slave Address	Rd	A	Data Byte	A	PEC	A	P

Read Word and Read Word with PEC

1	7	1	1	8	1	1	7	1	1	8	1
S	Slave Address	Wr	A	Command Code	A	S	Slave Address	Rd	A	Data Byte Low	A

8	1	1
Data Byte High	A	P

1	7	1	1	8	1	1	7	1	1	8	1
S	Slave Address	Wr	A	Command Code	A	S	Slave Address	Rd	A	Data Byte Low	A

8	1	8	1	1
Data Byte High	A	PEC	A	P

Block Read with PEC

1	7	1	1	8	1	1	7	1	1	8	1
S	Slave Address	Wr	A	Command Code	A	S	Slave Address	Rd	A	Byte Count=N	A

8	1	8	1	...	8	1	1
Data Byte 1	A	Data Byte 2	A	...	Data Byte N	A	P

1	7	1	1	8	1	1	7	1	1	8	1
S	Slave Address	Wr	A	Command Code	A	S	Slave Address	Rd	A	Byte Count=N	A

8	1	8	1	...	8	1	8	1	1
Data Byte 1	A	Data Byte 2	A	...	Data Byte N	A	PEC	A	P

Figure 15: PMBus™ Message Format

Direct Format Conversion

The MP5023 uses a direct format internally to represent real-world values, such as voltage, current, power, and temperature. A direct format number takes the form of a 2-byte, two's complement, binary integer value.

The decimal equivalent of all warning and telemetry words are constrained to be within the range of 0 to 1023.

Convert real-world values to a direct format with Equation (5):

$$Y = (mX + b) \times 10^R \quad (5)$$

Convert direct format values to real-world values with Equation (6):

$$X = \frac{1}{m} (Y \times 10^{-R} - b) \quad (6)$$

Where Y is the value in direct format, X is the calculated real-world value (A, V, W, °C, etc.), m is the slope coefficient (a 2-byte, two's complement integer), b is the offset (a 2-byte, two's complement integer), and R is a scaling exponent (a 1-byte, two's complement integer).

The same equations are used for voltage, current, power, and temperature conversions, with the only difference being the values of the m, b, and R coefficients used. Table 4 lists all the coefficients required for the MP5023.

Table 4: Direct Format Conversion to Real-Word Coefficients

Commands	m	b	R	Units
READ_IOUT IOUT_OC_WARN_LIMIT	16	0	0	A
READ_VIN READ_VOUT VIN_OV_WARN_LIMIT VIN_UV_WARN_LIMIT	32	0	0	V
READ_PIN READ_EIN	1	0	0	W
OT_FAULT_LIMIT OT_WARN_LIMIT READ_TEMPERATURE	2	0	0	°C
MFR_SPECIFIC_STARTUP_ CURRENT_LIMIT	4	50	-1	A

One-Time-Program (OTP) Memory

The MP5023 has multiple one-time programmable (OTP) memory. The memory writes are limited, and the remaining times can be read from the register MFR_OTP_LEFT (FEh). The MP5023 multi-OTP memory can be written more than 35 times, and each item in Table 5 update occupies 1-time OTP (see Table 5).

The default OTP time for each item in Table 5 is 50ms. Use 0.6s intervals for the sending STORE_USER_ALL command (15h) to save all

of the different registers to the OTP memory. The input voltage should be no less than 5V during an OTP write. Once the STORE_USER_ALL command is sent out, VCC is driven high to 5V. When the OTP program ends, VCC drops back to 3.3V.

When the STORE_USER_ALL command is sent out with the OTP register value unchanged, the MP5023 rejects the OTP request of the corresponding register internally, and the OTP remaining times are unchanged.

Table 5: OTP Registers List

Items	Name	Code	Type	Bytes	Comments
1	OPERATION	01h	r/w w/PEC	1	OTP
2	IOUT_CAL_GAIN	38h	r/w w/PEC	2	OTP
3	IOUT_CAL_OFFSET	39h	r/w w/PEC	2	OTP
4	IOUT_OC_WARN_LIMIT	4Ah	r/w w/PEC	2	OTP
5	OT_FAULT_LIMIT	4Fh	r/w w/PEC	2	OTP
6	OT_WARN_LIMIT	51h	r/w w/PEC	2	OTP
7	VIN_OV_WARN_LIMIT	57h	r/w w/PEC	2	OTP
8	VIN_UV_WARN_LIMIT	58h	r/w w/PEC	2	OTP
9	MFR_CTRL	F0h	r/w w/PEC	1	OTP
	MFR_ADDR_PMBUS	F1h	r/w w/PEC	1	
10	CONFIG_ID	F2h	r/w w/PEC	2	OTP
11	MFR_SPECIFIC_STARTUP_CURRENT_LIMIT	F6h	r/w w/PEC	2	OTP
	POWER_GOOD_ON	5Eh	r/w w/PEC	2	
12	POWER_GOOD_OFF	5Fh	r/w w/PEC	2	OTP

REGISTER DESCRIPTION

Name	Code	Type	Bytes	Default Value
OPERATION	01h	r/w w/PEC	1	80h
CLEAR_FAULTS	03h	Send byte w/PEC	0	-
STORE_USER_ALL	15h	Send byte w/PEC	0	-
RESTORE_USER_ALL	16h	Send byte w/PEC	0	-
CAPABILITY	19h	r w/PEC	1	D0h
IOUT_CAL_GAIN	38h	r/w w/PEC	2	00C8h
IOUT_CAL_OFFSET	39h	r/w w/PEC	2	0000h
IOUT_OC_WARN_LIMIT	4Ah	r/w w/PEC	2	0320h
OT_FAULT_LIMIT	4Fh	r/w w/PEC	2	01AAh
OT_WARN_LIMIT	51h	r/w w/PEC	2	0104h
VIN_OV_WARN_LIMIT	57h	r/w w/PEC	2	0220h
VIN_UV_WARN_LIMIT	58h	r/w w/PEC	2	006Ah
POWER_GOOD_ON	5Eh	r/w w/PEC	2	015Ah
POWER_GOOD_OFF	5Fh	r/w w/PEC	2	0120h
STATUS_BYTE	78h	r w/PEC	1	00h
STATUS_WORD	79h	r w/PEC	2	0000h
STATUS_INPUT	7Ch	r w/PEC	1	00h
STATUS_TEMPERATURE	7Dh	r w/PEC	1	00h
STATUS_CML	7Eh	r w/PEC	1	00h
READ_EIN	86h	Block read w/PEC	1(byte)+6(data)	06h, 0000h, 00h, 000000h
READ_VIN	88h	r w/PEC	2	0000h
READ_VOUT	8Bh	r w/PEC	2	0000h
READ_IOUT	8Ch	r w/PEC	2	0000h
READ_TEMPERATURE	8Dh	r w/PEC	2	0032h
READ_PIN	97h	r w/PEC	2	0000h
PMBUS_REVISION	98h	r w/PEC	1	33h
MFR_ID	99h	Block read w/PEC	1(byte)+3(data)	03h + ASCII"MP5"
MFR_MODEL	9Ah	Block read w/PEC	1(byte)+6(data)	06h + ASCII"MP5023"
MFR_REVISION	9Bh	Block read w/PEC	1(byte)+1(data)	01h + ASCII"0"
MFR_DATE	9Dh	Block read w/PEC	1(byte)+6(data)	06h + ASCII"YYMMDD"
MFR_CTRL	F0h	r/w w/PEC	1	FEh
MFR_ADDR_PMBUS	F1h	r/w w/PEC	1	31h
CONFIG_ID	F2h	r/w w/PEC	2	0000h
MFR_SPECIFIC_STARTUP_CURRENT_LIMIT	F6h	r/w w/PEC	2	000Fh
MFR_OTP_LEFT	FEh	r w/PEC	1	

PMBUS™ COMMANDS

OPERATION (01h)

The OPERATION command is used to control the power MOSFET switch, which provides another way to control the hot-swap on/off function using a command over the PMBus™. This command may be used to switch the power MOSFET on and off under the host control. This command is also used to re-enable the power MOSFET after a fault-triggered shutdown. Write an off command followed by an on command to clear all faults. Writing only an on command after a fault-triggered shutdown will not clear the fault registers.

OPERATION								
Format	Unsigned binary							
Bit	7	6	5	4	3	2	1	0
Access	r/w	r	r	r	r	r	r	r
Function		x	x	x	x	x	x	x
Default	1	0	0	0	0	0	0	0

Bit[7:6]	Bit[5:4]	Bit[3:2]	Bit[1:0]	On/Off	Margin State
0x	xx	xx	xx	Hot swap off	N/A
1x	xx	xx	xx	Hot swap on	Off

CLEAR_FAULTS (03h)

The CLEAR_FAULTS command is used to reset all stored warnings and fault flags. If a fault or warning condition still exists when the CLEAR_FAULTS command is issued, the ALERT# signal may not clear or re-asserts almost immediately. Issuing a CLEAR_FAULTS command will not cause the power MOSFET to switch back on in the event of a fault turn-off—this must be done by issuing an OPERATION command after the fault condition is cleared. This command uses the PMBus™ send byte protocol.

STORE_USER_ALL (15h)

Write the data from the MP5023 memory map to the internal OTP memory. This process operates when the MP5023 receive a STORE_USER_ALL command from the PMBus™ interface. This command has no data bytes and is write only.

RESTORE_USER_ALL (16h)

The RESTORE_USER_ALL command is used to copy the entire contents of the OTP memory to the MP5023 operating memory map. The values in the operating memory are overwritten by the value in the OTP memory.

CAPABILITY (19h)

The CAPABILITY command returns information about the PMBus™ functions supported by the MP5023. This command is read with the PMBus™ read byte protocol.

CAPABILITY								
Format	Unsigned binary							
Bit	7	6	5	4	3	2	1	0
Access	r	r	r	r	r	r	r	r
Function	PEC	Max. bus speed		Alert	x	x	x	x
Default	1	1	0	1	0	0	0	0
PEC supported, max speed 1MHz, supports SMBAlert and ARA								

IOUT_CAL_GAIN (38h)

The IOUT_CAL_GAIN command is used to set the IOUT calculation gain when different IMON resistors are used. This command uses bit[8:0] to set the calculation gain. Bit[15:9] is used to calibrate this gain to achieve a higher accuracy. Bit[15] is used for gain calibration sign bit. Bit[14] to bit[9] are the absolute values are used for calculation. The range of gain calibration is $\pm 3.076\%$. The range of GAIN is from 0 to 51.1mΩ.

The real-world value is $IOUT_CAL_GAIN = \text{Hex}(8:0) \times 0.1\text{m}\Omega / (1 \pm \text{Hex}(14:9)/2048)$.

Command	IOUT_CAL_GAIN															
Format	Direct															
Bit	15	14	13	12	11	10	9	8	7	6	5	4	3	2	1	0
Access	r/w	r/w	r/w	r/w	r/w	r/w	r/w	r/w	r/w	r/w	r/w	r/w	r/w	r/w	r/w	r/w
Function	Sign	Gain calibration						GAIN 0.1mΩ/LSB								
Default	0	0	0	0	0	0	0	0	1	1	0	0	1	0	0	0

Table 6 shows the gain calibration's (bit[15:9]) relationship between direct value and the real-world value.

Table 6: IOUT_CAL_GAIN Direct Value vs. Real-World Value

Sign	Direct Value (Hex)	Dec Value	Real World Value
0	000 000	0	0
0	000 001	1	0.0488%
0	111 111	63	3.076%
1	000 001	-1	-0.0488%
1	111 111	-63	-3.076%

IOUT_CAL_OFFSET (39h)

The IOUT_CAL_OFFSET command is used to offset the quantization error between IOUT_CAL_GAIN and the real analog value. The range of this register is $\pm 7.9A$. IOUT_CAL_OFFSET is a 2-byte, two's complement integer.

Command	IOUT_CAL_OFFSET															
Format	Direct															
Bit	15	14	13	12	11	10	9	8	7	6	5	4	3	2	1	0
Access	r	r	r	r	r	r	r	r	r/w	r/w	r/w	r/w	r/w	r/w	r/w	r/w
Function	x								Sign	62.5mA/LSB ($\pm 7.9375A$)						
Default	0	0	0	0	0	0	0	0	0	0	0	0	0	0	0	0

Table 7 shows the relationship between direct value and the real-world value.

Table 7: IOUT_CAL_OFFSET Direct Value vs. Real-World Value

Sign	Direct Value	Real World Value
0	000 0000	0
0	000 0001	62.5mA
0	111 1111	7937.5mA
1	000 0001	-7937.5mA
1	111 1111	-62.5mA

IOUT_OC_WARN_LIMIT (4Ah)

The IOUT_OC_WARN_LIMIT command is used to configure or read the threshold for over-current warning detection. If the sensed current exceeds this value, the IOUT_STATUS flag is set in the STATUS_WORD (79h) register, and the ALERT# signal is asserted.

Command	IOUT_OC_WARN_LIMIT															
Format	Direct															
Bit	15	14	13	12	11	10	9	8	7	6	5	4	3	2	1	0
Access	r	r	r	r	r	r	r/w	r/w	r/w	r/w	r/w	r/w	r/w	r/w	r/w	r/w
Function	x						62.5mA/LSB									
Default	0	0	0	0	0	0	1	1	0	0	1	0	0	0	0	0

OT_FAULT_LIMIT (4Fh)

The OT_FAULT_LIMIT is used to configure or read the threshold for over-temperature fault detection. If the measured temperature exceeds this value, an over-temperature fault is triggered, the over-temperature (OT) fault flags are set in the STATUS_BYTE (78h) and STATUS_TEMPERATURE (7Dh) registers, and the ALERT# signal is asserted. OT_FAULT_LIMIT is a 2-byte, two's complement integer, and bit[9] is the sign bit. The temperature range is -255°C to 255°C .

Command	OT_FAULT_LIMIT															
Format	Direct															
Bit	15	14	13	12	11	10	9	8	7	6	5	4	3	2	1	0
Access	r	r	r	r	r	r	r/w	r/w	r/w	r/w	r/w	r/w	r/w	r/w	r/w	r/w
Function	x						Sign	0.5°C/LSB								
Default	0	0	0	0	0	0	0	1	0	0	1	0	0	0	1	0

Table 8 shows the relationship between direct value and the real-world value.

Table 8: OT_FAULT_LIMIT Direct Value vs. Real-World Value

Sign	Direct Value	Real World Value/°C
0	0 0000 0000	0
0	0 0000 0001	0.5
0	1 1111 1111	+255.5
1	0 0000 0001	-255.5
1	1 1111 1111	-0.5

OT_WARN_LIMIT (51h)

The OT_WARN_LIMIT command is used to configure or read the threshold for over-temperature warning detection. If the sensed temperature exceeds this value, an over-temperature warning is triggered, the OT warn flags are set in the STATUS_BYTE (78h) and STATUS_TEMPERATURE (7Dh) registers, and the ALERT# signal is asserted. OT_WARN_LIMIT is a 2-byte, two's complement integer, and bit[9] is the sign bit. The relationship between the direct value and real-world value is the same as OT_FAULT_LIMIT.

Command	OT_WARN_LIMIT															
Format	Direct															
Bit	15	14	13	12	11	10	9	8	7	6	5	4	3	2	1	0
Access	r	r	r	r	r	r	r/w	r/w	r/w	r/w	r/w	r/w	r/w	r/w	r/w	r/w
Function	x						Sign	0.5°C/LSB								
Default	0	0	0	0	0	0	0	1	0	0	0	0	0	1	0	0

VIN_OV_WARN_LIMIT (57h)

The VIN_OV_WARN_LIMIT command is used to configure or read the threshold for input over-voltage warning detection. If the measured value of VIN rises above the value in this register, the VIN over-voltage (OV) warn flags are set in the respective registers, and the ALERT# signal is asserted.

Command	VIN_OV_WARN_LIMIT															
Format	Direct															
Bit	15	14	13	12	11	10	9	8	7	6	5	4	3	2	1	0
Access	r	r	r	r	r	r	r/w	r/w	r/w	r/w	r/w	r/w	r/w	r/w	r/w	r/w
Function	x						31.25mV/LSB									
Default	0	0	0	0	0	0	1	0	0	0	1	0	0	0	0	0

VIN_UV_WARN_LIMIT (58h)

The VIN_UV_WARN_LIMIT command is used to configure or read the threshold for input under-voltage warning detection. If the measured value of VIN falls below the value in this register, VIN under-voltage (UV) warn flags are set in the respective registers, and the ALERT# signal is asserted.

Command	VIN_UV_WARN_LIMIT															
Format	Direct															
Bit	15	14	13	12	11	10	9	8	7	6	5	4	3	2	1	0
Access	r	r	r	r	r	r	r/w	r/w	r/w	r/w	r/w	r/w	r/w	r/w	r/w	r/w
Function	x						31.25mV/LSB									
Default	0	0	0	0	0	0	0	0	1	0	1	0	0	1	0	1

POWER_GOOD_ON (5Eh)

The POWER_GOOD_ON command sets the output voltage at which an optional POWER_GOOD signal can be asserted. The default value is 015Ah, corresponding with 10.8V.

Command		POWER_GOOD_ON															
Format		Direct															
Bit	15	14	13	12	11	10	9	8	7	6	5	4	3	2	1	0	
Access	r	r	r	r	r	r	r/w	r/w	r/w	r/w	r/w	r/w	r/w	r/w	r/w	r/w	
Function	x						31.25mV/LSB										
Default	0	0	0	0	0	0	0	1	0	1	0	1	1	0	1	0	

POWER_GOOD_OFF (5Fh)

The POWER_GOOD_OFF command sets the output voltage at which an optional POWER_GOOD signal can be negated. The default value is 0120h, corresponding to 9V.

Command		POWER_GOOD_OFF															
Format		Direct															
Bit	15	14	13	12	11	10	9	8	7	6	5	4	3	2	1	0	
Access	r	r	r	r	r	r	r/w	r/w	r/w	r/w	r/w	r/w	r/w	r/w	r/w	r/w	
Function	x						31.25mV/LSB										
Default	0	0	0	0	0	0	0	1	0	0	1	0	0	0	0	0	

STATUS_BYTE (78h)

The STATUS_BYTE command returns the value of a number of flags indicating the state of the MP5023. Access to this command should use the read byte protocol. To clear bits in this register, the underlying fault should be removed and a CLEAR_FAULTS command issued.

Bits	Name	Behavior	Default Set	Description
[7]	Reserved		0	Always read as 0.
[6]	OFF	Live	1	0: hot swap gate drive enabled 1: hot swap gate drive disabled. This can be from an OC fault, OT fault, BAD FET fault, UV/OV fault, or the operation command to turn off
[5]	Reserved		0	Always read as 0.
[4]	IOUT_OC_FAULT	Latched	0	0: no OCP or SCP fault detected 1: OCP or SCP fault detected
[3]	Reserved		0	Always read as 0.
[2]	OT_FAULT_WARN	Latched	0	0: no over-temperature warning or fault detected 1: over-temperature warning or fault detected
[1]	CUMM_ERROR	Latched	0	0: no communication error detected 1: communication error detected
[0]	OTHER	Live	0	0: no other status bit asserted 1: other status bit asserted

STATUS_WORD (79h)

The STATUS_WORD returns the value of a number of flags indicating the state of the MP5023. To clear the bits in this register, the underlying fault should be removed and a CLEAR_FAULTS command issued.

Bits	Name	Behavior	Default Set	Description
[15]	VOUT_STATUS	Latched	0	0: no output fault, output off with drive disabled 1: output fault, output on with driver disabled. This can be due to a BAD FET fault.
[14]	IOUT_STATUS	Latched	0	Include IOUT_OC fault and warning. 0: no over-current condition is detected by the IOUT_OC_WARN_LIMIT command, or no OCP/SCP occurs 1: an over-current condition is detected by the IOUT_OC_WARN_LIMIT command or OCP/SCP occurs
[13]	VIN_STATUS	Latched	0	0: no VIN fault or warning 1: VIN fault or warning
[12]	MFR_STATUS		0	Always read as 0.
[11]	POWER_GOOD#	Live	0	0: power good signal is asserted 1: power good signal is not asserted
[10]	Reserved		0	Always read as 0.
[9]	Reserved		0	Always read as 0.
[8]	BAD_FET_HEALTH	Latched	0	0: MOSFET is good 1: MOSFET is bad
Low Byte	STATUS_BYTE			STATUS BYTE is the low byte of the STATUS WORD.

STATUS_INPUT (7Ch)

The STATUS_INPUT returns the value of the flags indicating the input voltage status, over-voltage, or under-voltage condition of the MP5023. To clear the bits in this register, the underlying fault or warning must be removed and a CLEAR_FAULTS command issued.

Bits	Name	Behavior	Default Set	Description
[7]	VIN_OV_FAULT	r, latched	0	0: no over-voltage detected on the OV pin 1: means over-voltage detected on the OV pin
[6]	VIN_OV_WARN	r, latched	0	0: over-voltage condition on VIN has not occurred 1: over-voltage condition on VIN has occurred
[5]	VIN_UV_WARN	r, latched	0	0: under-voltage condition on VIN has not occurred 1: under-voltage condition on VIN has occurred
[4:0]	Reserved	r	0	Always read as 0000.

STATUS_TEMPERATURE (7Dh)

The STATUS_TEMPERATURE returns the value of the flags indicating the over-temperature fault or warning. To clear the bits in this register, the underlying fault must be removed and a CLEAR_FAULTS command issued.

Bits	Name	Behavior	Default Set	Description
[7]	OT_FAULT	r, latched	0	1: over-temperature fault has occurred
[6]	OT_WARNING	r, latched	0	1: over-temperature warning has occurred
[5:0]	Reserved	r	0	Always read as 0.

STATUS_CML (7Eh)

The STATUS_CML returns the value of the flags indicating the command, data, or PEC communication faults. To clear bits in this register, a CLEAR_FAULTS command must be issued.

Bits	Name	Behavior	Default Set	Description
[7]	COMMAND_FAULT	r, latched	0	1: invalid or unsupported command received
[6]	DATA_FAULT	r, latched	0	1: invalid or unsupported data received
[5]	PEC_FAULT	r	0	1: packet error check (PEC) failed
[4:2]	Reserved	r	000	Always read as 000.
[1]	OTHERS			1: a communication fault other than the ones listed in this table has occurred
[0]	Reserved	r	0	Always read as 0.

READ_EIN (86h) Block Read

The READ_EIN command returns the 16 bits of the energy accumulator, the eight bits of the rollover counter, and the 24 bits of the sample counter. This is the preferred command for supporting input power monitoring. This command provides a more flexible method for power sensing so that the system can supply faster or slower power data depending on how fast it polls the device.

The READ_EIN register sampling period is about 290μs, the same with the READ_IOUT register update rate (3.4kHz). When READ_IOUT is sampled, the energy in (E_{IN}) and power in (P_{IN}) register is updated simultaneously. The combination of the accumulator and the rollover count may overflow within a few seconds. The host software should detect the overflow and handle it appropriately.

Byte	Name	Value	Description
[0]	Byte Count	0x06	Always reads as 0x06. This is the number of data bytes that the block read command should expect to read.
[1]	Low Byte	0x0000	Energy accumulator value in direct format. Byte[2] is the high byte, and byte[1] is the low byte. Internally, the energy accumulator is a 16-bit value.
[2]	High Byte		
[3]	Rollover Count	0x00	Number of times that the energy count has rolled over from 0x7FFF to 0x0000. This is a straight 8-bit binary value.
[4]	Low Byte	0x000000	This is the total number of P _{IN} samples acquired and accumulated in the energy count accumulator. Byte[6] is the high byte, byte[5] is the middle byte, and byte[4] is the low byte. This is a straight 24-bit binary value.
[5]	Middle Byte		
[6]	High Byte		

READ_VIN (88h)

The READ_VIN command returns the 10-bit measured value of the input voltage. This value is also used internally for VIN over-voltage and under-voltage warning detection.

Command	READ_VIN															
	Direct															
Format	15	14	13	12	11	10	9	8	7	6	5	4	3	2	1	0
Bit	r	r	r	r	r	r	r	r	r	r	r	r	r	r	r	r
Access	r	r	r	r	r	r	r	r	r	r	r	r	r	r	r	r
Function	x						31.25mV/LSB									
Default	0	0	0	0	0	0	0	0	0	0	0	0	0	0	0	0

READ_VOUT (8Bh)

The READ_VOUT command returns the 10-bit measured value of the output voltage.

Command	READ_VOUT															
Format	Direct															
Bit	15	14	13	12	11	10	9	8	7	6	5	4	3	2	1	0
Access	r	r	r	r	r	r	r	r	r	r	r	r	r	r	r	r
Function	x						31.25mV /LSB									
Default	0	0	0	0	0	0	0	0	0	0	0	0	0	0	0	0

READ_IOUT (8Ch)

The READ_VOUT command returns the 10-bit measured value of the output current. This value is also used for the IOUT_OC_WARNING comparison and affects STATUS_IOUT.

Command	READ_IOUT															
Format	Direct															
Bit	15	14	13	12	11	10	9	8	7	6	5	4	3	2	1	0
Access	r	r	r	r	r	r	r	r	r	r	r	r	r	r	r	r
Function	x						62.5mA/LSB									
Default	0	0	0	0	0	0	1	0	0	1	0	1	1	0	0	0

READ_TEMPERATURE (8Dh)

The READ_TEMPERATURE command returns the internal sensed temperature. This value is also used internally for over-temperature fault and warning detection. This data has a range of -255°C to +255°C. READ_TEMPERATURE is a 2-byte, two's complement integer, with bit[9] as the sign.

Command	READ_TEMPERATURE															
Format	Direct															
Bit	15	14	13	12	11	10	9	8	7	6	5	4	3	2	1	0
Access	r	r	r	r	r	r	r/w	r/w	r/w	r/w	r/w	r/w	r/w	r/w	r/w	r/w
Function	x						Sign	0.5°C /LSB								
Default value	0	0	0	0	0	0	0	0	0	0	1	1	0	0	1	0

Table 9 shows the relationship between the direct value and real-world value.

Table 9: READ_TEMPERATURE Direct Value vs. Real-World Value

Sign	Direct Value	Real World Value/°C
0	0 0000 0000	0
0	0 0000 0001	0.5
0	1 1111 1111	+255.5
1	0 0000 0001	-255.5
1	1 1111 1111	-0.5

READ_PIN (97h)

The READ_PIN command returns the internal input power. P_{IN} is the power from the VIN x IOUT calculation.

Command	READ_PIN															
Format	Direct															
Bit	15	14	13	12	11	10	9	8	7	6	5	4	3	2	1	0
Access	r	r	r	r	r	r	r	r	r	r	r	r	r	r	r	r
Function	x						1W/LSB									
Default value	0	0	0	0	0	0	0	0	0	0	0	0	0	0	0	0

PMBUS_REVISION (98h)

The PMBUS_REVISION command returns the protocol revision used. Access to this command should use the read byte protocol. Bit[7:4] indicates the PMBus™ revision of the PMBUS specification Part I to which the device is compliant. Bit[3:0] indicates the revision of the PMBus™ specification Part II to which the device is compliant.

PMBUS_REVISION								
Format	Unsigned binary							
Bit	7	6	5	4	3	2	1	0
Access	r	r	r	r	r	r	r	r
Default	0	0	1	0	0	0	1	0

Bit[7:4] is always read as 0011 (specification PMBus™ Part I Revision 1.3).

Bit[3:0] is always reads as 0011 (specification PMBus™ Part II Revision 1.3).

MFR_ID (99h)

The MFR_ID command returns the company identification. The reset value is 0x4D 50 53.

Byte	Name	Value	Description
0	Byte Count	0x03	Always reads as 0x03. This is the number of data bytes that the block read command expects to read.
1	Character 1	0x53 or “S”	Always read as 0x53.
2	Character 2	0x50 or “P”	Always read as 0x50.
3	Character 3	0x4D or “M”	Always read as 0x4D.

MFR_MODEL (9Ah)

The MFR_MODEL command returns the part name, 0x4D 50 35 30 32 33.

Byte	Name	Value	Description
0	Byte Count	0x06	Always read as 0x06. This is the number of data bytes that the block read command expects to read.
1	Character 1	0x33 or “3”	Always read as 0x33.
2	Character 2	0x32 or “2”	Always read as 0x32.
3	Character 3	0x30 or “0”	Always read as 0x30.
4	Character 4	0x35 or “5”	Always read as 0x35.
5	Character 5	0x50 or “P”	Always read as 0x50.
6	Character 6	0x4D or “M”	Always read as 0x4D.

MFR_REVISION (9Bh)

The MFR_REVISION command returns the part revision.

Byte	Name	Value	Description
0	Byte Count	0x01	Always reads as 0x01. This is the number of data bytes that the block read command expects to read.
1	Character 1	0x30 or “0”	Always read as 0x30.

MFR_DATE (9Dh)

The MFR_DATE command returns the part's manufacture date with the format ASCII "YYMMDD." For example, if the manufacture date is 2015-07-19, then the MFR_DATE value is 0x31 35 30 37 31 39. Please note that the value in this table is used for reference and is not actual real manufacture date.

Byte	Name	Value	Description
0	Byte Count	0x06	Always read as 0x06. This is the number of data bytes that the block read command expects to read.
6	Character 6	0x31	YY. Identifies the year that the part is manufactured.
5	Character 5	0x35	
4	Character 4	0x30	
3	Character 3	0x37	MM. Identifies the month that the part is manufactured.
2	Character 2	0x31	
1	Character 1	0x39	DD. Identifies the day that the part is manufactured.

MFR_CTRL (F0h)

The MFR_CTRL command is used to configure and read the output pull-down discharge mode and protection mode. The PD bit is for output power discharge, the AUTO bit is used for over-current and thermal protection mode selection, and the AUTO_OV bit is used to set the over-voltage protection mode.

Bits	Name	Access	Behavior	Default Set	Description
[7:6]	Reserved	r		11	Always read as 11.
[5:4]	ENTM	r/w	Live	11	00: LOADEN blanking time is set to 1s 01: LOADEN blanking time is set to 2s 10: LOADEN blanking time is set to 4s 11: LOADEN blanking time is set to 8s
[3]	ISTART_EN	r/w	Live	1	0: the start-up current limit is determined by the normal ISET 1: the start-up current limit is determined by the start-up current limit register value (F6h).
[2]	AUTO_OV	r/w	Live	1	Sets the over-voltage protection mode. 0: over-voltage latch off 1: over-voltage auto-retry
[1]	PD	r/w	Live	1	0: disables pull-down mode when the power MOSFET is turned off. The output voltage is discharged by the load. 1: enables pull-down mode when the power MOSFET is turned off.
[0]	AUTO	r/w	Live	0	0: over-current or thermal latch off 1: over-current or thermal auto-retry

MFR_ADDR_PMBUS (F1h)

Command	MFR_ADDR_PMBUS							
Format	Unsigned binary							
Bit	7	6	5	4	3	2	1	0
Access	r/w	r/w	r/w	r/w	r/w	r/w	r/w	r/w
Function	Enable	ADDR						
Default	0	0	1	1	0	0	0	1

When the enable bit is 1, the address is decided by MFR_ADDR_PMBUS. When the enable bit is 0, the address is decided by ADDR.

CONFIG_ID (F2h)

The CONFIG_ID is a manufacturer-specific command used to set the code configuration for the customer. The default value is 0000h.

Command	CONFIG_ID															
Format	Unsigned binary															
Bit	15	14	13	12	11	10	9	8	7	6	5	4	3	2	1	0
Access	r	r	r	r	r	r	r/w	r/w	r/w	r/w	r/w	r/w	r/w	r/w	r/w	r/w
Function	x						CONFIG_ID									
Default	0	0	0	0	0	0	0	0	0	0	0	0	0	0	0	0

MFR_SPECIFIC_STARTUP_CURRENT_LIMIT (F6h)

The MFR_SPECIFIC_STARTUP_CURRENT_LIMIT command is a manufacturer-specific command that returns a specific start-up current limit. Access to this command should use the word write protocol. This register range is from 12.5 - 50A with 2.5A/LSB. The direct value can be determined by Equation (7):

$$I_{STARTUP_LIMIT} = 2.5 * Y + 12.5 \quad (7)$$

Where Y means the direct value.

Command	MFR_SPECIFIC_STARTUP_CURRENT_LIMIT															
Format	Direct															
Bit	15	14	13	12	11	10	9	8	7	6	5	4	3	2	1	0
Access	r	r	r	r	r	r	r/w	r/w	r/w	r/w	r/w	r/w	r/w	r/w	r/w	r/w
Function	x											2.5A/LSB				
Default	0	0	0	0	0	0	0	0	0	0	0	0	1	1	1	1

Table 10 shows the relationship between the direct value and real-world value.

Table 10: MFR_SPECIFIC_STARTUP_CURRENT_LIMIT Direct Value vs. Real-World Value

Direct Value	Real Value (A)
0000	12.5
0001	15.0
1111	50.0

MFR_OTP_LEFT (FEh)

The MFR_OTP_LEFT command is read only command and is used to set the OTP remaining (left) timers to program.

Command	MFR_OTP_LEFT							
Format	Unsigned binary							
Bit	7	6	5	4	3	2	1	0
Access	r	r	r	r	r	r	r	r
Function	OTP left times							
Default	0	0	0	0	0	0	0	0

PACKAGE INFORMATION

FCQFN-24 (4mmx5mm)

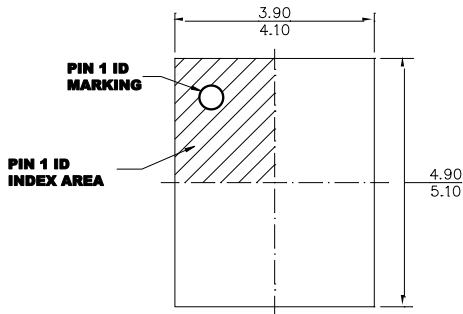

TOP VIEW

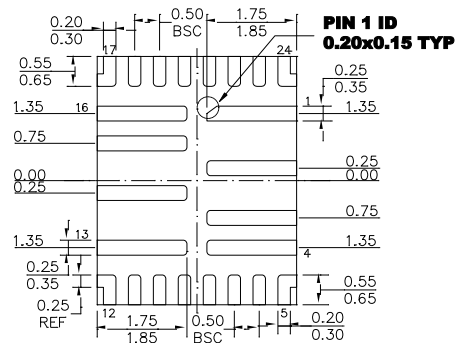

BOTTOM VIEW

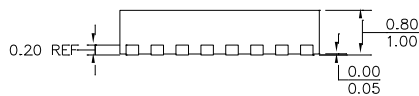

SIDE VIEW

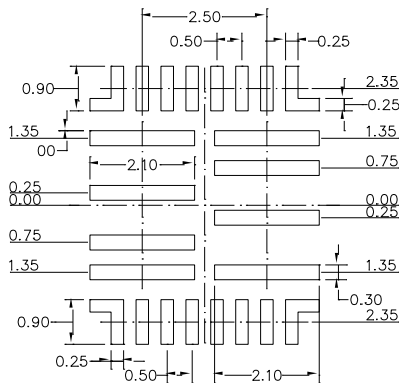

RECOMMENDED LAND PATTERN

NOTE:

- 1) LAND PATTERNS OF PIN1-4 AND PIN13-16 HAVE THE SAME LENGTH AND WIDTH.
- 2) LAND PATTERNS OF PINS5,12,17 AND 24 HAVE THE SAME SHAPE.
- 3) LAND PATTERNS OF PIN6-11 AND PIN18-23 HAVE THE SAME LENGTH AND WIDTH.
- 4) ALL DIMENSIONS ARE IN MILLIMETERS.
- 5) EXPOSED PADDLE SIZE DOES NOT INCLUDE MOLD FLASH.
- 6) LEAD COPLANARITY SHALL BE 0.08 MILLIMETERS MAX.
- 7) JEDEC REFERENCE IS MO-220.
- 8) DRAWING IS NOT TO SCALE.

NOTICE: The information in this document is subject to change without notice. Please contact MPS for current specifications. Users should warrant and guarantee that third party Intellectual Property rights are not infringed upon when integrating MPS products into any application. MPS will not assume any legal responsibility for any said applications.