

January 1994

**DESCRIPTION**

The SSI 32C9301 is an advanced CMOS VLSI device which integrates major portions of the hardware needed to build an ATA disk drive. The SSI 32C9301 can operate on 3.3 volts or 5 volts allowing use in 3.3 volt or 5 volt disk drives. The circuitry of the SSI 32C9301 includes a complete ATA interface, an advanced buffer manager, a high performance disk formatter and an 88 bit Reed-Solomon ECC with fast "on-the-fly" hardware correction. The SSI 32C9301 provides maximum performance while minimizing microcontroller intervention.

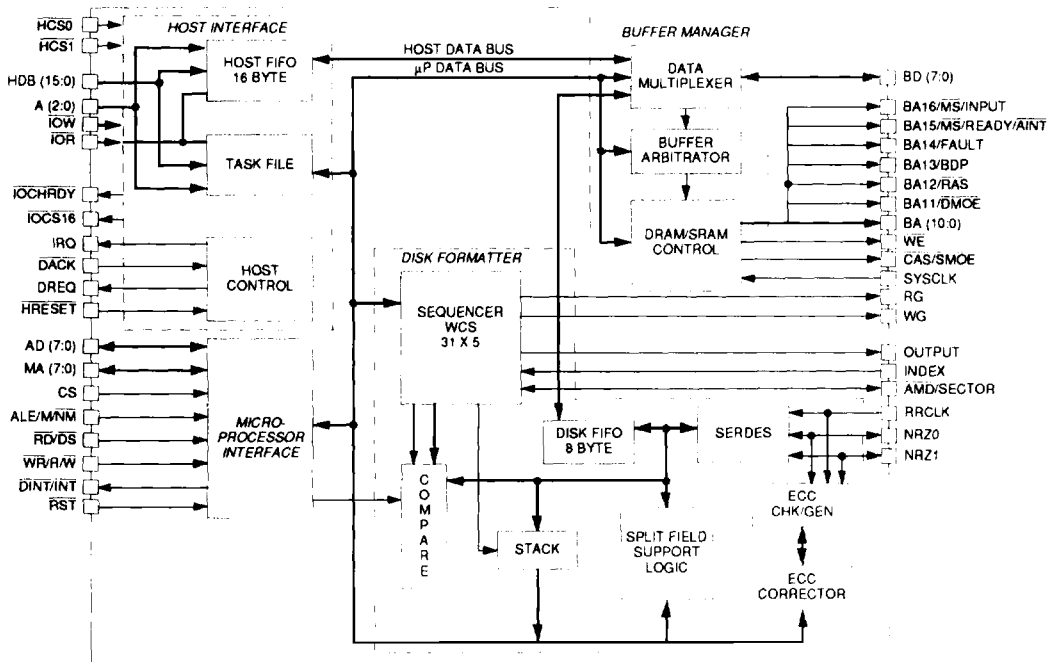
When operating in a 3.3 volt environment, the SSI 32C9301 is capable of concurrent transfers of up to 48 megabits per second on the disk interface and 3 megawords (16 bit transfers) per second across the

(continued)

**FEATURES**

- **ATA Interface**
  - **Single Chip PC AT Controller**
  - **Full ANSI ATA Compliance**
  - **Direct PC Bus connection with on board 8 mA (12 mA @5v) drivers**
  - **PC transfers to 4 (6.7 @5v) megawords per second**
  - **Supports PIO, DMA and multiword DMA (EISA Class B Demand DMA)**
  - **Logic for daisy chaining 2 drives**
  - **Operates as master, slave or both**
  - **Automatic command decoding of write, write long, write DMA, write multiple, write buffer and format commands** (continued)

**BLOCK DIAGRAM**



# SSI 32C9301

## PC-AT Combo Controller

### With Reed Solomon, 3V Operation

---

#### DESCRIPTION (continued)

ATA bus. In a 5 volt environment, the SSI 32C9301 is capable of concurrent transfers of up to 48 megabits per second on the disk interface and 6 megawords per second across the ATA bus. The SSI 32C9301 is capable of performing concurrent disk data transfers, host data transfers, on-the-fly error corrections and micro controller accesses of the buffer memory without any degradation of performance on any interface.

The SSI 32C9301 is one of a family of Silicon Systems' single chip disk controllers which support a wide range of device interfaces. The SSI 32C9001 is a 5 volt only version of the 32C9301 which is 100% firmware and pin out compatible. The 32C9302 is another 3.3/5 volt ATA controller which supports a dual NRZ disk formatter interface. The SSI 32C9020, SSI 32C9022, SSI 32C9023 and SSI 32C9024 family members are SCSI disk controllers. The SSI 32C9340 disk controller completes the family by providing PCMCIA/ATA compliant interfaces. All members are based on a common architecture allowing major portions of firmware to be reused. The Silicon Systems' chip family is illustrated in hierarchy chart shown in Figure 1.

The high level of integration within the SSI 32C9301 represents a major reduction in parts count. When the SSI 32C9301 ATA Controller is combined with the SSI 32R2300 Read/Write device, the SSI 32P4330 Pulse Detector with 1,7 ENDEC, the SSI 32H6300 Servo and Motor Speed Controller, an appropriate micro controller and memory, a complete, cost efficient, high performance intelligent drive solution is created.

#### FEATURES (continued)

- Automatic updates of the host task file registers in both Cyl/Hd/Sec and LBA modes
  - Hardware support for write-multiple and read-multiple commands.
  - Hardware added to provide Multi-Sector data transfers without microprocessor intervention
  - Automatic Host Interrupt and Busy for multiple sector transfers
  - 16 byte FIFO to improve performance
  - Separate host interface VDD to allow 3.3 volt drives to plug into 5 volt systems
  - Power Down I/O pins
- Buffer Manager
    - Direct support of DRAM or SRAM
    - SRAM: up to 128k bytes of memory with throughput to 16 (20 @5v) megabytes per second
    - DRAM: up to 1 megabyte of memory with throughput to 12 (17.78 @5v) megabytes per second
    - Programmable memory timing
    - Supports page mode DRAM access
    - Programmable page mode burst length
    - Programmable DRAM refresh period
    - Buffer RAM segmentation with flexible segment sizes from 256 bytes to 1 megabyte
    - Dedicated host, disk and microprocessor address pointers
    - Buffer Streaming with internal buffer protection circuit providing buffer integrity
  - Disk Formatter
    - NRZ Data Rates to 48 megabits per second
    - Automatic multi-sector transfer
    - Header or microprocessor based split data field support
    - Advanced sequencer organized in 31 x 5 bytes
    - Advanced branch and interrupt logic
    - 88-bit Reed Solomon ECC with "on-the-fly" fast hardware correction circuitry
    - Capable of correcting up to four 10-bit symbols in error
    - Guaranteed to correct one 31-bit burst or two 11-bit bursts
    - Hardware on-the-fly correction of either an 11-bit single burst error within one half of a sector time
    - Detects up to one 51-bit burst or three 11-bit bursts
  - Microprocessor Interface
    - Supports both Intel and Motorola microprocessors
    - Separate or combined host and disk interrupts
  - Other Features
    - Internal power down mode
    - Available in 100-pin TQFP
    - Automatic power supply level detection
    - Conforms to JEDEC 3.3 volt specifications
    - TTL compatible input receivers at 3.3V or 5V

# SSI 32C9301

## PC-AT Combo Controller

### With Reed Solomon, 3V Operation

#### FUNCTIONAL DESCRIPTION

The SSI 32C9301 contains the following four major functional blocks:

- Microprocessor Interface
- ATA Interface
- Disk Formatter
- Buffer Manager

The Microprocessor Interface allows the local microprocessor access to all of the SSI 32C9301 internal control registers and any location within the buffer memory. The microprocessor, by writing and reading the internal registers, can control all activities of the SSI 32C9301. The microprocessor can elect to perform host and/or disk operations directly, or it can enable the advanced features of the SSI 32C9301 which can perform these operations automatically.

The ATA Interface block handles all PC AT bus activities. The ATA interface includes 8 mA (12 mA @5v) drivers allowing for direct connection of the SSI 32C9301 to the PC AT bus. The ATA interface block is highly automated, capable of performing multiple block transfers without micro controller involvement. The ATA block interfaces directly with the Buffer Manager via an internal speed matching FIFO. This FIFO, the

bandwidth capabilities of the Buffer Manager, plus the advanced features of the ATA Interface guarantee sustained full speed transfers across the PC AT bus.

The Disk Formatter performs the serialization and deserialization of data. It provides all of the necessary functions to control track formatting, header search, and the reading and writing of data. The heart of the Disk Formatter is an advanced programmable sequencer. The sequencer can contain 31 instructions, each of which is 5 bytes (40 bits) in width. The width of the instructions allows for sophisticated branching techniques which increase the flexibility and power of the sequencer. The disk interface can be configured through a wide range of capabilities, allowing the SSI 32C9301 to interface with nearly any read/write channel. This allows the user of the SSI 32C9301 to select the read/write channel best suited to the device. Of course, by selecting the SSI 32C9301 controller and the SSI 32P4330 Read Channel with 1,7 ENDEC, you are guaranteed a problem free interface.

Within the Disk Formatter are the ECC generator/checker and ECC corrector. The generator/checker provides the ability to generate or check a 32-bit ECC for headers and an 88-bit Reed Solomon code for data. If the checker detects an error using the 88-bit Reed Solomon code, the syndrome information is transferred

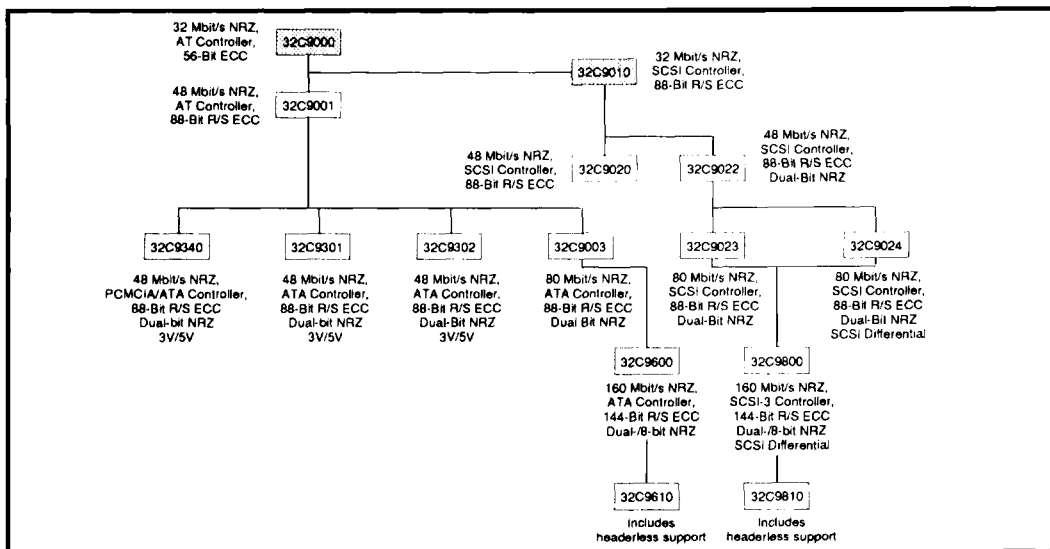


FIGURE 1: Silicon Systems' Disk Controller Chip Hierarchy

# SSI 32C9301

## PC-AT Combo Controller

### With Reed Solomon, 3V Operation

#### FUNCTIONAL DESCRIPTION (continued)

into the corrector. The corrector then performs the necessary operations to determine if the error was correctable and, if it was correctable, the corrector interfaces directly with the buffer controller and performs the correction automatically. The corrector performs its correction within one quarter of a sector. This guarantees that the corrector will always be available to correct the next sector if necessary.

The Buffer Manager manages the data buffer of the controller. The Buffer Manager can support either SRAM or DRAM. When configured to operate with DRAM, the Buffer Manager automatically performs necessary refresh cycles. The buffer manager creates

all of the necessary timing and control signals for a wide range of memory types and speeds. Besides interfacing with the buffer memory, the Buffer Manager interfaces with the ATA Interface block, the Disk Formatter block, the ECC corrector of the Disk Formatter block and the microprocessor. If more than one of these devices requires access to the buffer memory, the Buffer Manager arbitrates the requests automatically. The Buffer Manager of the SSI 32C9301 can sustain ATA operations at the rate of 3 (6 @5v) megawords per second, Disk Formatter operations at 48 megabits per second and still has sufficient band width left to handle on-the-fly ECC corrections and microprocessor accesses without degrading performance on any of the interfaces.

#### PIN DESCRIPTION

The following convention is used in the pin description:

- (I) denotes an input
- (I/S) denotes a Schmitt trigger input
- (O) denotes an output
- (I/O) denotes a bidirectional signal
- (Z) denotes a tri-state output
- (OD) denotes an open drain output

Active low signals are denoted by a bar on top of the signal name and dual function pins are denoted with a slash between the two signals —  $\overline{\text{AMD}}/\text{SECTOR}$

#### GENERAL

NAME	TYPE	DESCRIPTION
VDD		POWER SUPPLY PIN
GND		GROUND

#### HOST INTERFACE

A(2:0)	I	HOST ADDRESS LINES. The Host Address lines A(2:0) and A9 are used to access the various PC/AT control/status, and data registers.
HCS1	I	HOST CHIP SELECT 1. This pin is used to select the control block task file register.
HCS0	I	HOST CHIP SELECT 0. This pin is used to access the command block task file registers.
IOCS16	OD	16 BIT DATA TRANSFER. An active low output that indicates that a 16-bit buffer transfer is active.
IRQ	O	INTERRUPT REQUEST. Asserted active high to indicate to the Host that the controller needs attention.

# SSI 32C9301 PC-AT Combo Controller With Reed Solomon, 3V Operation

## HOST INTERFACE (continued)

NAME	TYPE	DESCRIPTION
$\overline{\text{IORDY}}$	O,Z	I/O READY. Active low, this signal is asserted whenever the internal host FIFO is not ready to transfer data.
DREQ	O,Z	DMA REQUEST. The active high DMA Request signal is used during DMA to transfer between the Host and the SSI 32C9301.
$\overline{\text{DACK}}$	I	DMA ACKNOWLEDGE. This active low signal is used during DMA to transfer data between the host and the controller.
$\overline{\text{IOR}}$	I	INPUT READ SELECT. This active low pin is asserted by the Host during a Host read operation. When asserted with $\overline{\text{HCS0}}$ , $\overline{\text{HCS1}}$ , or $\overline{\text{DACK}}$ , data from the device is enabled onto the host data bus.
$\overline{\text{IOW}}$	I	INPUT WRITE SELECT. Asserted active low by the HOST during a HOST write operation. When asserted with $\overline{\text{HCS0}}$ , $\overline{\text{HCS1}}$ , or $\overline{\text{DACK}}$ , data from the host data bus is strobed into the device.
$\overline{\text{HRESET}}$	I	HOST RESET. This active low signal stops all commands in progress and initializes the control/status registers. This signal can also "wake up" the device while it is in power down mode.
HDB(15:0)	I/O	HOST DATA BUS. These bits are used for word transfers between the Buffer Memory and the Host; bits (7:0) are used for status, commands, or ECC byte transfers.
$\overline{\text{PDIAG}}$	I,OD	PASSED DIAGNOSTICS. This pin is used as the Passed Diagnostics signal, and may be an input or an open-drain output.
$\overline{\text{DASP}}$	I, OD	DRIVE ACTIVE-SLAVE PRESENT. This pin is used as the Drive Active/Slave Present signal, and is an input or and open-drain output. This pin is used for Master/Slave drive communication and/or for driving an LED.

## DISK INTERFACE

INDEX/INPUT	I	INDEX/INPUT. This pin serves as the index function for the disk sequencer. When the INPUT function is not available on the BA16 pin, this pin can function as input or index.
OUTPUT	O	DISK SEQUENCER OUTPUT. This pin is controlled by bit 2 of the control field of the disk sequencer.
$\overline{\text{AMD}}/\text{SECTOR}$	I/O	ADDRESS MARK DETECT/SECTOR. In Hard Sector mode, this is the input for the sector pulse from the disk drive. In Soft Sector mode, a low-level input during a read indicates an address mark was detected.
RG	O	READ GATE. This active high output enables the reading of the disk. It is asserted at the beginning of the PLO for header and data field by the sequencer — sequencer Control Field bits 5 and 6. It is automatically deasserted at the end of the CRC or ECC.

# SSI 32C9301

## PC-AT Combo Controller

### With Reed Solomon, 3V Operation

#### PIN DESCRIPTION (continued)

##### DISK INTERFACE (continued)

NAME	TYPE	DESCRIPTION
WG	O	WRITE GATE. This active high output enables writing onto the disk. It is asserted and deasserted by the sequencer Control Field bits 5 and 6.
RRCLK	I	READ/REFERENCE CLOCK. This pin is used in conjunction with the NRZ pin to clock data in and out of the SSI 32C9001 device. This input must be glitch-free to ensure correct operation of the chip.
NRZ0	I/O	NRZ BIT 0. This signal is the read data input from the disk drive when the read gate signal is asserted; it is the write data output to the disk drive when the write gate signal is asserted. This pin is used for the least significant bit in dual bit NRZ mode; it is used for the serial data stream in single bit NRZ mode.
NRZ1	I/O	NRZ BIT 1. This signal is the read data input from the disk drive when the read gate signal is asserted; it is the write data output to the disk drive when the write gate signal is asserted. This pin is used for the most significant bit in dual bit NRZ mode; it is not used in single bit NRZ mode.

##### MICROPROCESSOR INTERFACE

$\overline{RST}$	I/S	RESET. An asserted active low input generates a component reset that holds the internal registers of the SSI 32C9301 at reset, stops all operations within the chip, and deasserts all output signals. All input/output signals and Host outputs are set to the high-Z state.																																				
ALE/M/NM	I	ADDRESS LATCH ENABLE/MULTIPLEXED/NON-MULTIPLEXED ADDRESS SELECT. When tied high or left floating after reset, the microprocessor interface is configured as non-multiplexed. When driven low, then the microprocessor interface is configured as multiplexed. In this case this pin functions as the address latch enable, and the MA(7:0) pins are the demultiplexed address outputs.																																				
CS	I	CHIP SELECT. This signal must be asserted high for all microprocessor accesses to the registers of this chip.																																				
$\overline{WR/R\overline{W}}$	I	WRITE STROBE/READ/WRITE. In the Multiplexed Microprocessors bus mode, when an active low signal is present with CS signal asserted high, the data on the AD0:7 is written to the internal registers.  In the Non-Multiplexed Microprocessors bus mode, this signal acts as the R/ $\overline{W}$ signal. A high on this input along with the $\overline{RD/DS}$ signal high and the CS signal asserted high indicates a read operation. A low on this input along with the $\overline{RD/DS}$ signal asserted and the CS signal asserted high indicates a write operation. See table below.																																				
		<table border="1"> <thead> <tr> <th><math>\overline{I/M\overline{C}}</math></th> <th>CS</th> <th><math>\overline{WR/R\overline{W}}</math></th> <th><math>\overline{RD/DS}</math></th> <th>Action</th> <th>Mux/Non-Mux</th> </tr> </thead> <tbody> <tr> <td>High</td> <td>High</td> <td>Low</td> <td>High</td> <td>Write to internal registers.</td> <td>M</td> </tr> <tr> <td>High</td> <td>High</td> <td>High</td> <td>Low</td> <td>Read from internal registers.</td> <td>M</td> </tr> <tr> <td>Low</td> <td>High</td> <td>Low</td> <td>High</td> <td>Write to internal registers.</td> <td>N</td> </tr> <tr> <td>Low</td> <td>High</td> <td>High</td> <td>High</td> <td>Read from internal registers.</td> <td>N</td> </tr> <tr> <td>X</td> <td>Low</td> <td>X</td> <td>X</td> <td>No action.</td> <td>M or N</td> </tr> </tbody> </table>	$\overline{I/M\overline{C}}$	CS	$\overline{WR/R\overline{W}}$	$\overline{RD/DS}$	Action	Mux/Non-Mux	High	High	Low	High	Write to internal registers.	M	High	High	High	Low	Read from internal registers.	M	Low	High	Low	High	Write to internal registers.	N	Low	High	High	High	Read from internal registers.	N	X	Low	X	X	No action.	M or N
$\overline{I/M\overline{C}}$	CS	$\overline{WR/R\overline{W}}$	$\overline{RD/DS}$	Action	Mux/Non-Mux																																	
High	High	Low	High	Write to internal registers.	M																																	
High	High	High	Low	Read from internal registers.	M																																	
Low	High	Low	High	Write to internal registers.	N																																	
Low	High	High	High	Read from internal registers.	N																																	
X	Low	X	X	No action.	M or N																																	
		Note: X denotes don't care.																																				

# SSI 32C9301

## PC-AT Combo Controller

### With Reed Solomon, 3V Operation

#### MICROPROCESSOR INTERFACE (continued)

$\overline{RD}/\overline{DS}$	I	<p>READ STROBE/DATA STROBE. In the Multiplexed Microprocessors bus mode, when an active low signal is present with CS signal high, internal registers will be accessed.</p> <p>In the Non-Multiplexed Microprocessors mode, this signal acts as the DS signal. A high on the DS, <math>\overline{R}/\overline{W}</math>, and the CS signals, indicates a read operation. A low on the <math>\overline{R}/\overline{W}</math> signal, highs on both the DS and the CS, indicates a write operation to the internal registers.</p>
$\overline{DINT}/\overline{INT}$	O, OD, Z	<p>INTERRUPT. An active low signal indicates the controller is requesting microprocessor service from the disk side. This signal is programmable for either a push-pull with an internal pull up resistor or open-drain output circuit. This signal powers up in the high-Z state. Disk Formatter Mode Control Register, 4FH: bit 3 set high, programs this pin as a push-pull, and when set low programs it as an open drain output signal.</p>
AD(7:0)	I/O	<p>ADDRESS/DATA BUS. When configured in the Multiplexed Microprocessors mode, these lines are multiplexed, bidirectional data path to the microprocessor. During the beginning of the memory cycle the bus captures the low order byte of the microprocessor address. These lines provide communication with the controller device's internal registers and the buffer memory.</p> <p>When configured in the Non-Multiplexed Microprocessors mode, these lines are bidirectional data lines.</p>
MA(7:0)	I/O	<p>MICROPROCESSOR ADDRESS BUS: This 8-bit output bus is the AD(7:0) bus latched by the ALE pin during the low order address phase of an Multiplexed Microprocessors type microprocessor cycle. These signals are nonmultiplexed address input when used with a non-multiplexed bus microprocessor — Non-Multiplexed Microprocessors interface.</p>

#### BUFFER MANAGER INTERFACE

BA16/ $\overline{MS}$ /INPUT	I/O	<p>BUFFER ADDRESS 16/MEMORY SELECT/DISK INPUT. In SRAM mode, this pin may be configured as buffer address 16, memory select, or as the input pin to the disk sequencer. In DRAM mode, this pin is configured as the input pin. If the input function is not available on this pin, then the INDEX pin may be used for the index function or the input function.</p>
BA15/ $\overline{MS}$ /READY/ $\overline{AINT}$	O	<p>BUFFER ADDRESS 15/MEMORY SELECT/AT INTERRUPT/READY. In SRAM mode, this pin may be configured as buffer address 15, memory select, as a separate local microprocessor interrupt for the host interface, or as the ready function for adding wait states to local microprocessor accesses. In DRAM mode, AT interrupt or Ready may be selected. After <math>\overline{RST}</math> is asserted, this signal is configured as Ready.</p>
BA14/FAULT	I/O	<p>BUFFER MEMORY ADDRESS 14/DISK FAULT. This signal is used for addressing the buffer memory in SRAM mode, or as the disk fault pin in DRAM mode. Assertion of the fault pin will cause the disk sequencer to halt immediately.</p>
BA13/BDP	I/O	<p>BUFFER MEMORY ADDRESS 13/BUFFER MEMORY PARITY. This signal is used for addressing the buffer memory in SRAM mode, or as the buffer data parity value in DRAM mode.</p>

7

# SSI 32C9301

## PC-AT Combo Controller

### With Reed Solomon, 3V Operation

#### PIN DESCRIPTION (continued)

#### BUFFER MANAGER INTERFACE (continued)

NAME	TYPE	DESCRIPTION
BA12/ $\overline{\text{RAS}}$	O	BUFFER MEMORY ADDRESS 12/ROW ADDRESS STROBE: This signal is used for addressing the buffer memory in SRAM mode or as the row address strobe in DRAM mode. After $\overline{\text{RST}}$ is asserted, this signal will be high.
BA11/ $\overline{\text{DMOE}}$	O	BUFFER MEMORY ADDRESS 11/DRAM MEMORY OUTPUT ENABLE. This signal is used for addressing the buffer memory in SRAM mode, or as the memory output enable pin in DRAM mode. After $\overline{\text{RST}}$ is asserted, this signal will be high.
BA(10:0)	O	BUFFER MEMORY ADDRESS LINES. These are signals 10-0 for addressing the buffer memory.
BD(7:0)	I/O	BUFFER MEMORY DATA BUS. 7 through 0. The bidirectional Data Bus connects directly to the buffer memory. This bus is designed for high speed data transfer.
$\overline{\text{CAS}}$ / $\overline{\text{SMOE}}$	O	COLUMN ADDRESS STROBE/SRAM MEMORY OUTPUT ENABLE. This signal is used as the column address strobe in DRAM mode, or the memory output enable in SRAM mode. After $\overline{\text{RST}}$ is asserted, this signal will be high.
$\overline{\text{WE}}$	O	MEMORY OUTPUT ENABLE. This active low output signal is used to strobe the data into the RAMs from the Data bus. For both buffer memory applications, this line is tied directly to the SRAM or DRAM control pin.
SYSCLK	I	SYSTEM CLOCK. This signal is used to synchronize the buffer RAM access, including the generation of memory address lines, write enable $\overline{\text{WE}}$ , and memory output enable $\overline{\text{MOE}}$ . In power down mode, this signal is shut off from the internal logic and hence buffer memory access is inhibited.

# SSI 32C9301

## PC-AT Combo Controller

### With Reed Solomon, 3V Operation

#### ELECTRICAL SPECIFICATIONS

##### ABSOLUTE MAXIMUM RATINGS

Maximum limits indicate where permanent device damage occurs. Continuous operation at these limits is not intended and should be limited to those conditions specified in the DC operating characteristics.

PARAMETER	RATING
Power Supply Voltage, VCC	7V
Ambient Temperature	0 to 70°C
Storage Temperature	-65 to 150°C
Power Dissipation	750 mW
Input, Output pins	-0.5 to VCC + 0.5V

##### ELECTRICAL CHARACTERISTICS

PARAMETER	CONDITIONS	MIN	MAX	MIN	MAX	UNIT
		3.3V	3.3V	5V	5V	
VDD Power Supply Voltage		3	3.6	4.5	5.5	V
IDD Supply Current			30		50	mA
IDDS Standby Current	Note 1		250		250	μA
VIL Input Low Voltage		-0.5	0.8	-0.5	0.8	V
VIH Input High Voltage	Except $\overline{RST}$ pin	2	VCC + 0.5	2	VCC + 0.5	V
VIH Input High Voltage	$\overline{RST}$ pin	2	VCC + 0.5	3.9	VCC + 0.5	V
VOL Output Low Voltage	Note 2		0.4		0.4	V
VOL Output Low Voltage	Note 3		0.5		0.5	V
VOH Output High Voltage	IOH = -400 μA	2.15		2.4		V
IL Input Leakage Current	0 < VIN < VCC	-10	10	-10	10	μA
CIN Input Capacitance			10		10	pF
COUT Output Capacitance			10		10	pF

Note: (1) Synchronization and Clock Control Register, 7FH: bits 3 and 4 set. RRCLK and SYSCLK internally inhibited.  
(2) All interface pins except Host Interface pins. IOL = 2 mA.  
(3) Host Interface pins, IOL = 16 mA @ 3.3V, IOL = 24 mA @ 5.0V.

# SSI 32C9301

## PC-AT Combo Controller

### With Reed Solomon, 3V Operation

#### ELECTRICAL SPECIFICATIONS (continued)

#### MICROPROCESSOR INTERFACE TIMING PARAMETERS

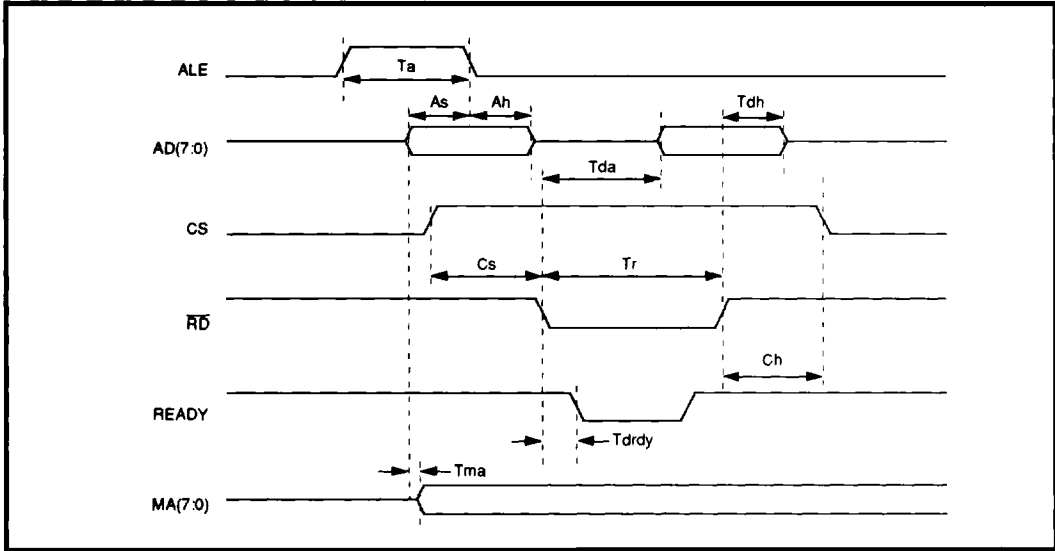
##### Multiplexed Bus Interface Timings (Figures 2, 3, 4, 5)

PARAMETER	CONDITIONS	MIN 3.3V	MAX 3.3V	MIN 5V	MAX 5V	UNIT
Ta	ALE Width	20		20		ns
Tma	Address valid to MA (7:0) valid		45		30	ns
Tr	$\overline{RD}$ Width	80		80		ns
As	Address valid to ALE $\downarrow$	5		5		ns
Ah	ALE $\downarrow$ to address invalid	10		10		ns
Cs	CS valid to $\overline{RD}$ $\downarrow$ or $\overline{DS}$ $\downarrow$	20		20		ns
Ch	$\overline{RD}$ $\uparrow$ or $\overline{DS}$ $\uparrow$ to CS $\downarrow$	0		0		ns
Tda	$\overline{RD}$ $\downarrow$ or $\overline{DS}$ $\downarrow$ to read data valid		40		30	ns
Tda	$\overline{RD}$ $\downarrow$ or $\overline{DS}$ $\downarrow$ to read data valid		60		50	ns
Tds	$\overline{DS}$ width	80		80		ns
Tdh	RD $\uparrow$ to or $\overline{DS}$ $\uparrow$ read data invalid	0	25	0	25	ns
Tsrw	R/W valid to $\overline{DS}$ $\downarrow$	20		20		ns
Thrw	$\overline{DS}$ $\uparrow$ to R/W invalid	20		20		ns
Tdrdy	$\overline{RD}$ $\downarrow$ to READY $\downarrow$ (Intel) or $\overline{DS}$ $\downarrow$ to READY $\downarrow$ (Motorola)		45		30	ns ns
Wds	Write data valid to $\overline{WR}$ $\uparrow$ or $\overline{DS}$ $\uparrow$	40		40		ns
Wdh	$\overline{WR}$ $\uparrow$ or $\overline{DS}$ $\uparrow$ to write data invalid	10		10		ns

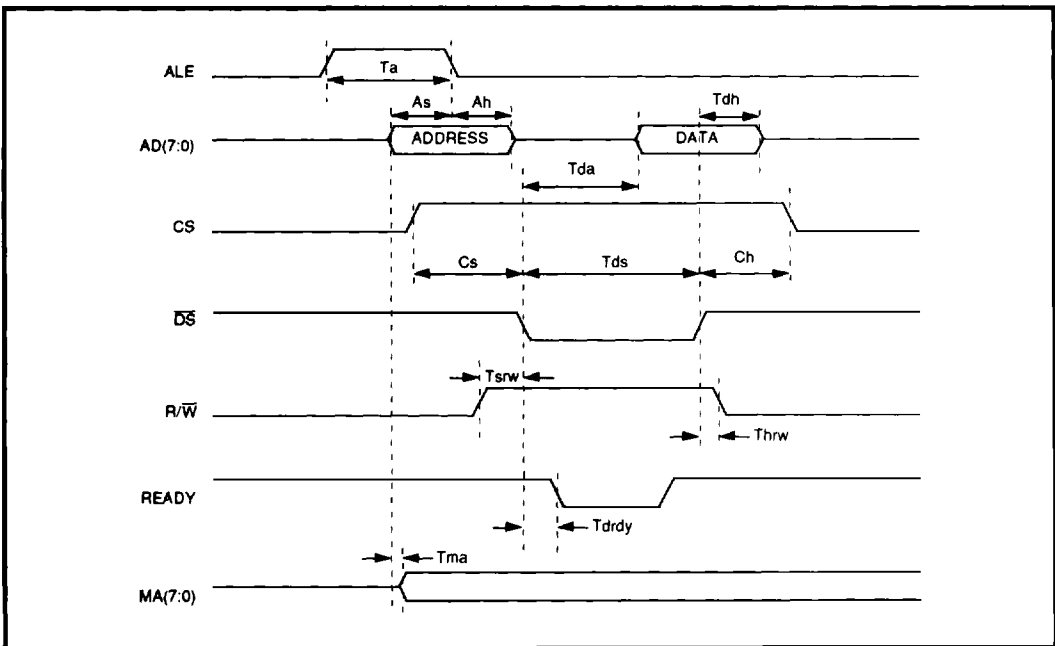
##### Non-Multiplexed Bus Interface Timings (Figure 6)

Tmas	MA (7:0) valid to $\overline{DS}$ $\downarrow$	5		5		ns
Tmah	$\overline{DS}$ $\uparrow$ to MA (7:0) invalid	5		5		ns
Cs	CS valid to $\overline{DS}$ $\downarrow$	20		20		ns
Ch	$\overline{DS}$ $\uparrow$ to CS $\downarrow$	0		0		ns
Tda	$\overline{RD}$ $\downarrow$ or $\overline{DS}$ $\downarrow$ to read data valid		40		30	ns
Tda	$\overline{RD}$ $\downarrow$ or $\overline{DS}$ $\downarrow$ to read data valid		60		50	ns
Tds	$\overline{DS}$ width	80		80		ns
Tdh	$\overline{DS}$ $\uparrow$ to read data invalid	0	25	0	25	ns
Tsrw	R/W valid to $\overline{DS}$ $\downarrow$	20		20		ns
Thrw	$\overline{DS}$ $\uparrow$ to R/W invalid	20		20		ns
Tdrdy	$\overline{DS}$ $\downarrow$ to READY $\downarrow$ (Motorola)		45		30	ns
Wds	Write data valid to $\overline{WR}$ $\uparrow$ or $\overline{DS}$ $\uparrow$	40		40		ns
Wdh	$\overline{WR}$ $\uparrow$ or $\overline{DS}$ $\uparrow$ to write data invalid	10		10		ns
Note: (1) Loading capacitor = 30 pF						
(2) $\uparrow$ indicates rising edge $\downarrow$ indicates falling edge						

**SSI 32C9301**  
**PC-AT Combo Controller**  
**With Reed Solomon, 3V Operation**

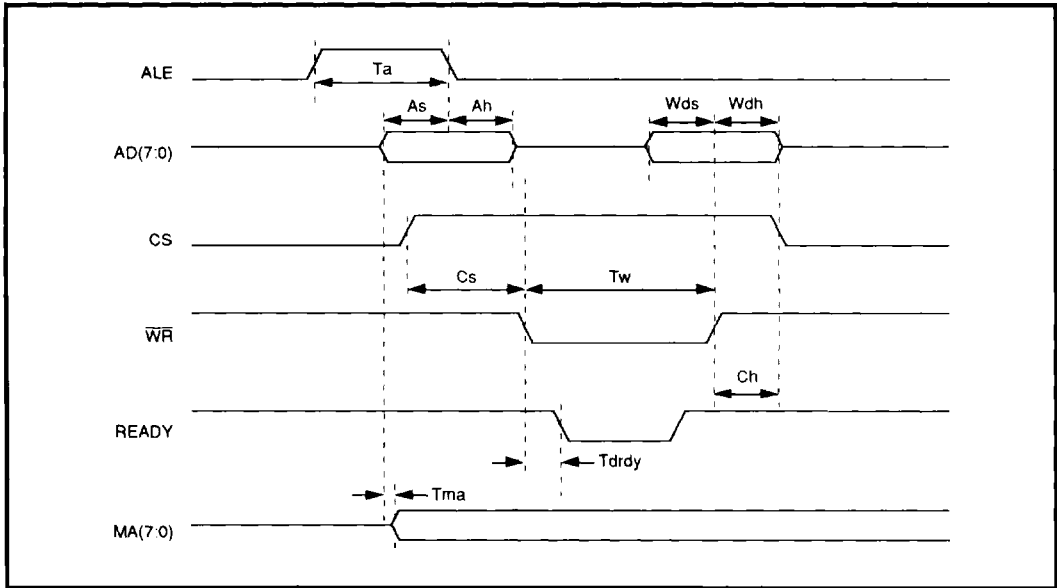


**FIGURE 2: Intel Register Multiplexed Read Timing**

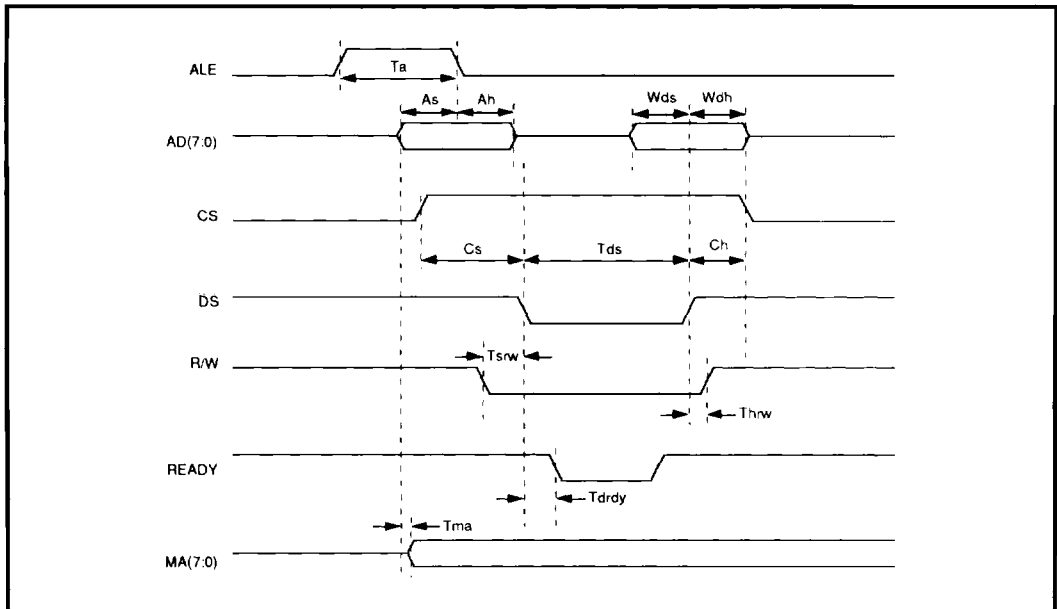


**FIGURE 3: Motorola Register Multiplexed Read Timing**

**SSI 32C9301  
PC-AT Combo Controller  
With Reed Solomon, 3V Operation**

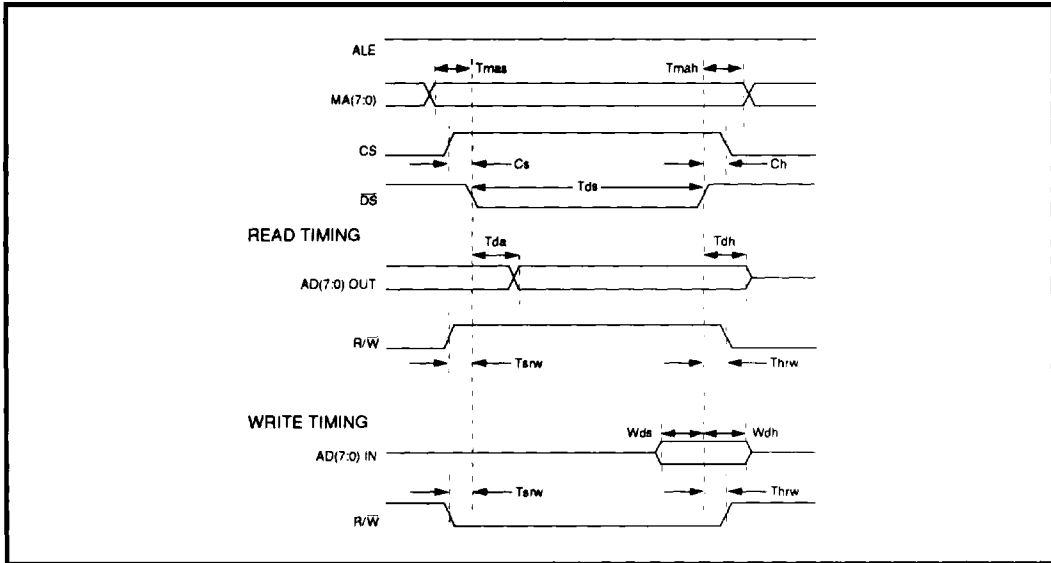


**FIGURE 4: Intel Register Multiplexed Write Timing**



**FIGURE 5: Motorola Register Multiplexed Write Timing**

**SSI 32C9301**  
**PC-AT Combo Controller**  
**With Reed Solomon, 3V Operation**



**FIGURE 6: Non-Multiplexed Bus Timing Diagrams**

**ELECTRICAL SPECIFICATIONS** (continued)

**MICROPROCESSOR INTERFACE TIMING PARAMETERS**

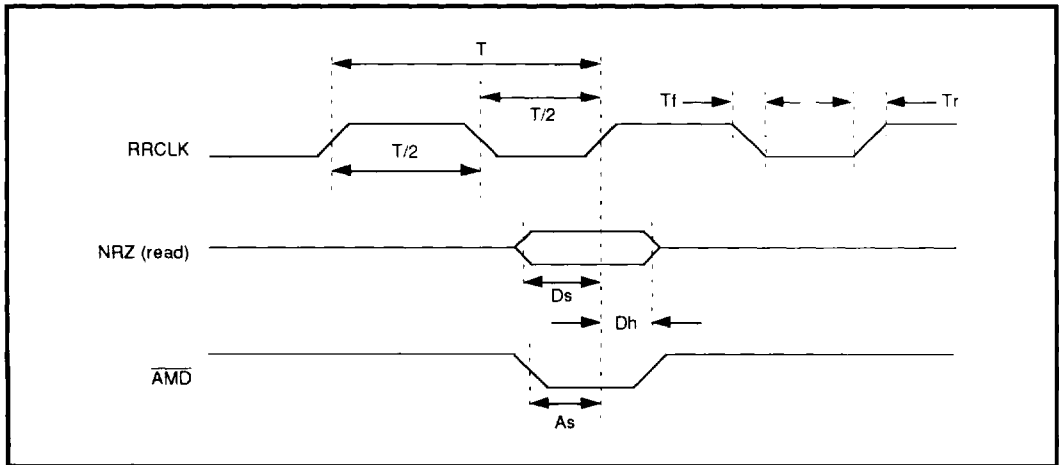
**Disk Read/Write Timing (Figure 7)**

PARAMETER	CONDITIONS	MIN 3.3V	MAX 3.3V	MIN 5V	MAX 5V	UNIT
T	RRCLK period (dual bit)	41		41		ns
	RRCLK period (single bit)	31		20.8		ns
T/2	RRCLK low time (dual bit)	16		16		ns
	RRCLK low time (single bit)	12		8.5		ns
Ds	NRZ in valid to RRCLK high	5		3		ns
Dh	RRCLK high to NRZ in invalid	5		3		ns
As	AMD valid to RRCLK high (soft sector only)	5		3		ns
Dv	RRCLK high to NRZ1, NRZ0 out valid	5	27	3	18	ns
Tr, Tt	RRCLK rise and fall time		3		2	ns

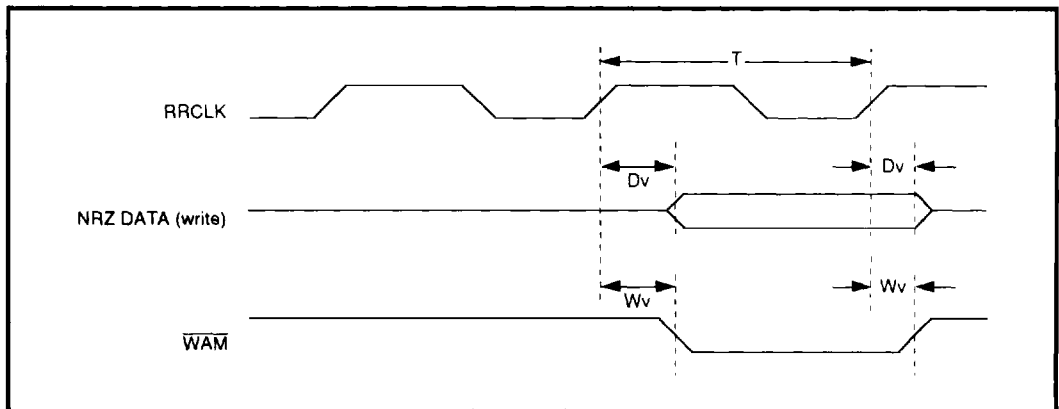
Note: Loading capacitance = 10 pF

7

**SSI 32C9301  
PC-AT Combo Controller  
With Reed Solomon, 3V Operation**



**FIGURE 7: Disk Read Timing**



**FIGURE 8: Disk Write Timing**

**SSI 32C9301**  
**PC-AT Combo Controller**  
**With Reed Solomon, 3V Operation**

**BUFFER MEMORY READ/WRITE TIMING PARAMETERS (Figures 8 through 13)**

PARAMETER		CONDITIONS	MIN 3.3V	MAX 3.3V	MIN 5V	MAX 5V	UNIT
T	SYSCLK period		28		25		ns
T/2	SYSCLK high/low time		12		10		ns
Tav	SYSCLK ↑ to address valid	(Note 1)		35		18	ns
Tmsv	SYSCLK ↑ to $\overline{MS}$ ↓	(Notes 1, 6)		35		18	ns
Tmsh	SYSCLK ↑ to $\overline{MS}$ ↑	(Note 1)		35		18	ns
Tmv	SYSCLK ↑ to $\overline{MOE}$ ↓	(Note 1)		35		18	ns
Tmh	SYSCLK ↑ to $\overline{MOE}$ ↑	(Note 1)		35		18	ns
Tww	SYSCLK ↑ to $\overline{WE}$ ↓	(Note 1)		35		18	ns
Twh	SYSCLK ↑ to $\overline{WE}$ ↑	(Note 1)		35		18	ns
Tdov	SYSCLK ↑ to data out valid	(Note 1)		35		18	ns
Tdoh	SYSCLK ↑ to data out invalid	(Note 1)		35		18	ns
Tdis	Data in valid to $\overline{MOE}$ ↑ (SRAM) Data in valid to $\overline{CAS}$ ↑ (DRAM)		5		5		ns
Tdih	$\overline{MOE}$ ↑ to data in valid (SRAM) $\overline{CAS}$ ↑ to data in valid (DRAM)		0		0		ns
Trv	SYSCLK ↑ to $\overline{RAS}$ ↓	(Note 1)		35		18	ns
Trh	SYSCLK ↑ to $\overline{RAS}$ ↑	(Note 1)		35		18	ns
Trav	SYSCLK ↑ to row address valid	(Note 1)		35		18	ns
Trah	SYSCLK ↑ to row address invalid	(Note 1)		35		18	ns
Tcv	SYSCLK ↑ to $\overline{CAS}$ ↓	(Note 1)		35		18	ns
Tch	SYSCLK ↑ to $\overline{CAS}$ ↑	(Note 1)		35		18	ns
Tcav	SYSCLK ↑ to column address valid	(Note 1)		35		18	ns
Tcah	SYSCLK ↑ to column address invalid		0		0		ns

7

# SSI 32C9301

## PC-AT Combo Controller

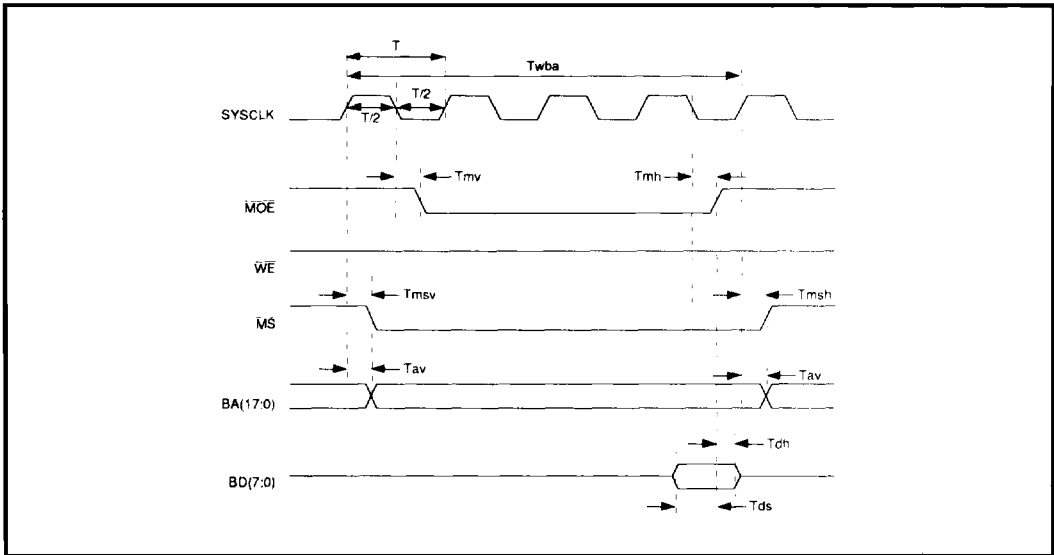
### With Reed Solomon, 3V Operation

#### ELECTRICAL SPECIFICATIONS (continued)

#### BUFFER MEMORY READ/WRITE FUNCTIONAL PARAMETERS (Figures 9 through 12) (continued)

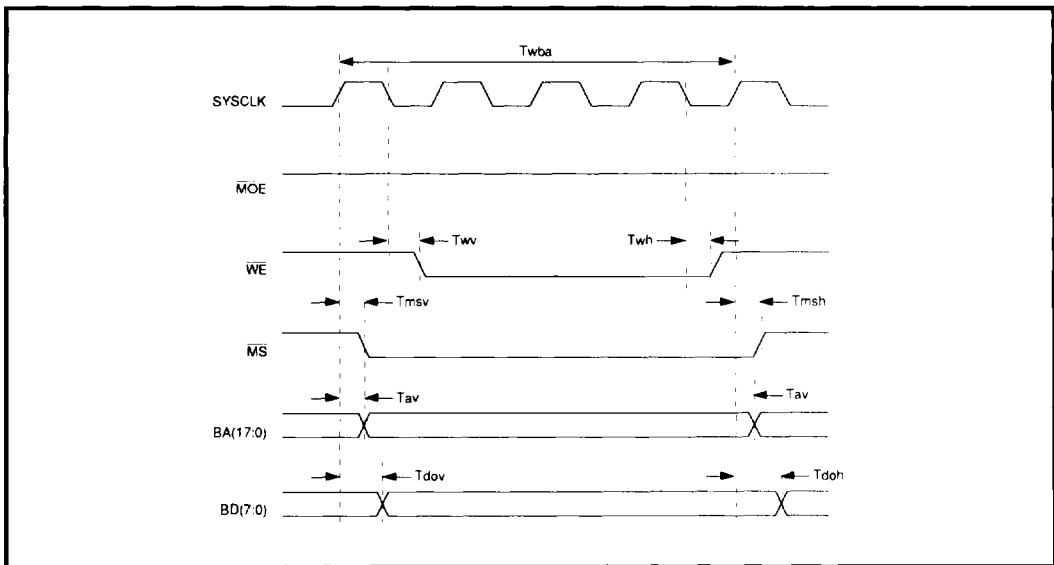
PARAMETER	CONDITIONS	MIN	UNIT	
Trwl	$\overline{RAS}\uparrow$ to $\overline{RAS}\downarrow$	Notes 2, 3	$(RWL + 3) \cdot T$	ns
Trwh	$\overline{RAS}\downarrow$ to $\overline{RAS}\uparrow$	Notes 2, 4	$(RWH + 1) \cdot T$	ns
Tcwl	$\overline{CAS}\uparrow$ to $\overline{CAS}\downarrow$	Note 2	$(CWL + 1) \cdot T$	ns
Tcwh	$\overline{CAS}\downarrow$ to $\overline{CAS}\uparrow$	Notes 2, 5	$(CWL + 1) \cdot T$	ns
Note:	Loading capacitance = 30 pF			
Note 1:	The measured delay for any of the signal indicated by this note will not vary from the measured delay of any other signal indicated by this note by more than TBD (3V), $\pm 2$ ns (5V).			
Note 2:	RWL, RWH, CWL and CWH are fields in the Buffer Manager Timing Control Register (54H). Each is a two bit field which can contain a value of 0, 1, 2, or 3. These values determine the minimum number of SYSCLK periods (T) for the associated signal width.			
Note 3:	The minimum width value of Trwl will be generated for refresh cycles and for any buffer memory access cycle except when multiple page mode accesses are performed. When multiple page mode accesses are performed, the width of the $\overline{RAS}$ low pulse is extended until the end of the last $\overline{CAS}$ low cycle.			
Note 4:	The minimum value of Trwh will be generated whenever the Buffer Manager determines that a buffer request is pending at the completion of the current memory cycle and a page mode access can not be used either because page mode operation is not enabled or the needed location is not within the current page.			
Note 5:	The minimum value of Tcwh will be generated only between consecutive page mode accesses.			
Note 6:	$\overline{MS}$ will rise only if the Buffer Manager determines that no additional requests for buffer access are pending. If the Buffer Manager determines that another access is to be made, $\overline{MS}$ is kept low between the accesses for improved speed.			

# SSI 32C9301 PC-AT Combo Controller With Reed Solomon, 3V Operation



Note: Twba is a functional parameter that gives the duration of one RAM data buffer access cycle in SYSCLK periods. The value is programmed in bits 1-0 of register 54H. These examples show Twba = 4T.

**FIGURE 9: SRAM Read Timing**



**FIGURE 10: SRAM Write Timing**

# SSI 32C9301 PC-AT Combo Controller With Reed Solomon, 3V Operation

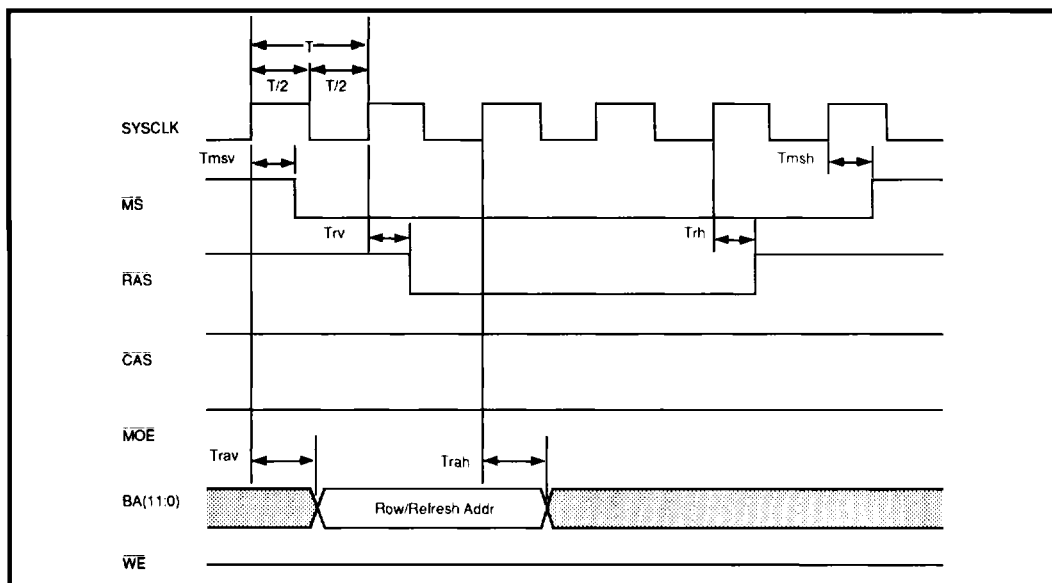


FIGURE 11: DRAM Timing, Refresh Cycle (shown with WRL = 0)

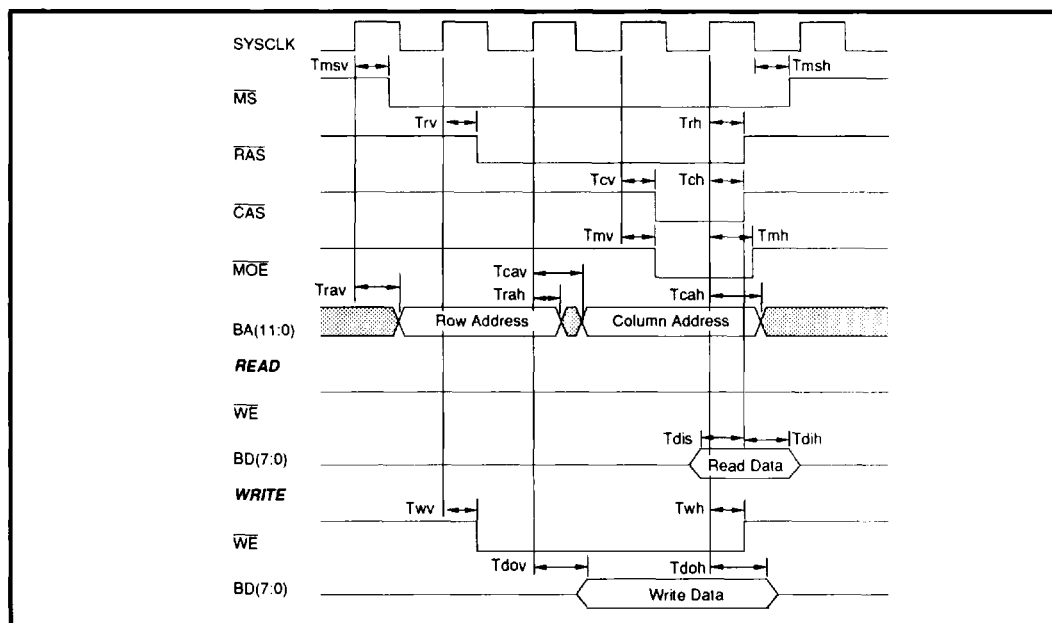
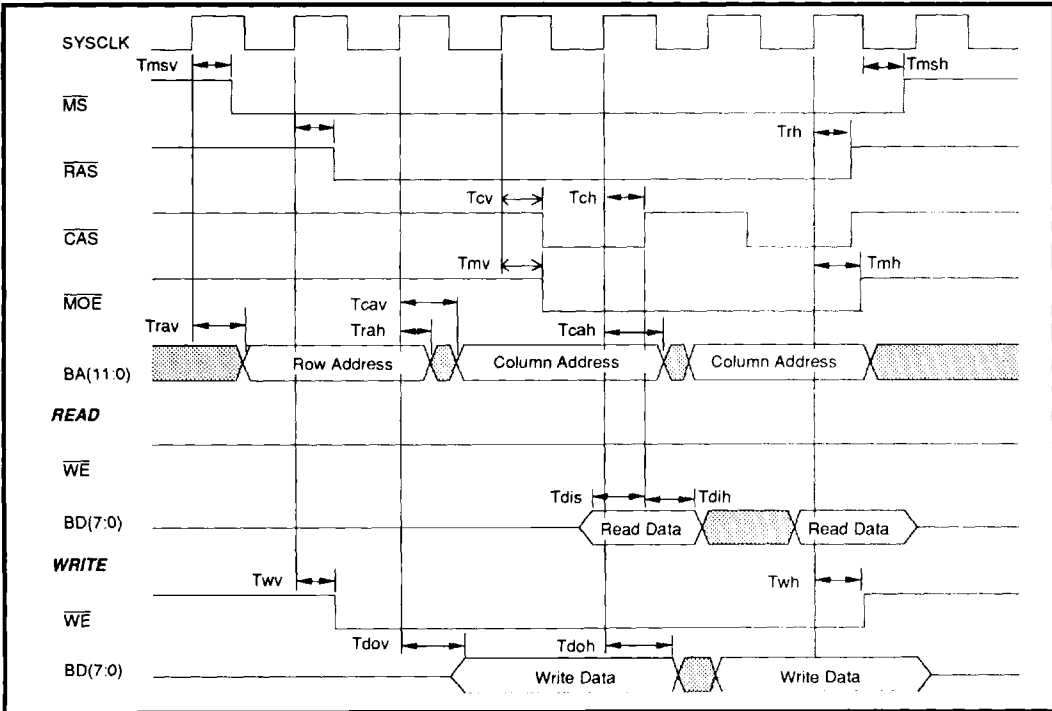
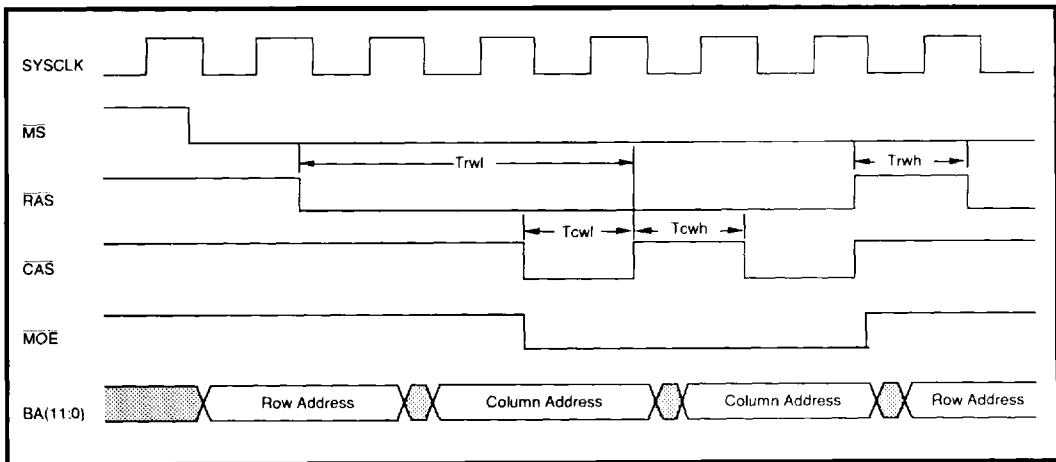


FIGURE 12: DRAM Timing, Standard Cycle (shown with RWL = 0 and CWL = 0)

**SSI 32C9301**  
**PC-AT Combo Controller**  
**With Reed Solomon, 3V Operation**



**FIGURE 13: DRAM Timing, Fast Page Cycles (shown with RWL = 0, RWH = 0, CWL = 0 and CWH = 0)**



**FIGURE 14: DRAM Timing (showing the relationship of RWL, RWH, CWL and CWH to overall timing)**

# SSI 32C9301

## PC-AT Combo Controller

### With Reed Solomon, 3V Operation

#### ELECTRICAL SPECIFICATIONS (continued)

##### AT Host Interface Timing Parameters

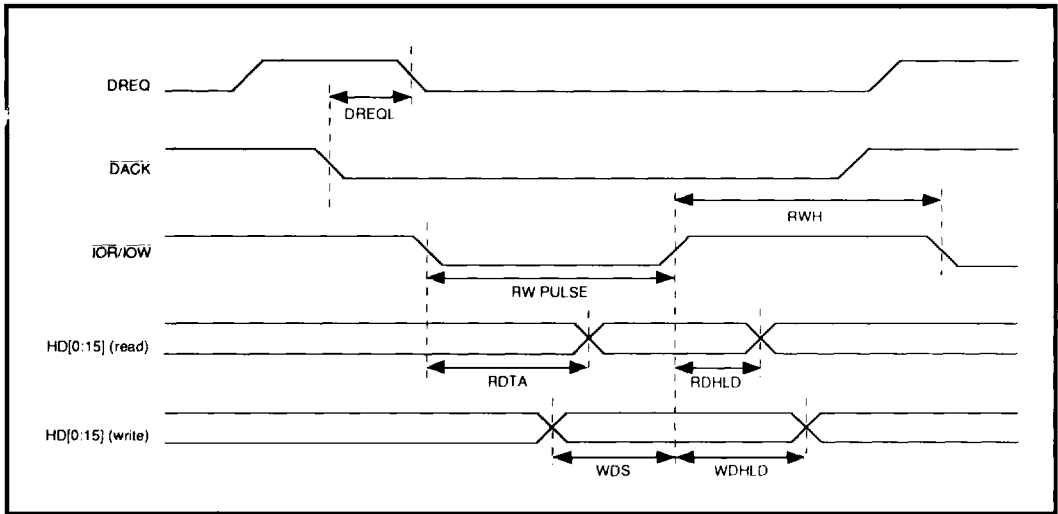
PARAMETER	MIN	MAX	MIN	MAX	UNIT
	3.3V	3.3V	5V	5V	
DREQL $\overline{DACK} \downarrow$ to DREQ $\downarrow$		50		40	ns
RDTA $\overline{IOR} \downarrow$ to HD(15:0) valid		70		50	ns
DMASET $\overline{DACK} \downarrow$ to $\overline{IOW} \downarrow$ or $\overline{IOR} \downarrow$	0		0		ns
DMAHLD $\overline{IOR} \uparrow$ or $\overline{IOW} \uparrow$ to $\overline{DACK} \uparrow$	0		0		ns
RDHLD $\overline{IOR} \uparrow$ to HD(15:0) hi-Z	2	25	2	25	ns
WDS HD(15:0) setup to $\overline{IOW} \uparrow$	40		30		ns
WDHLD HD(15:0) hold from $\overline{IOW} \uparrow$	10		10		ns
RWPULSE $\overline{IOR}$ or $\overline{IOW}$ low pulse width	80		80		ns
RWH $\overline{IOR}$ or $\overline{IOW}$ high pulse width	50		50		ns
CS16L $\overline{HCS0} \downarrow$ , A(2:0) $\downarrow$ , A9 $\downarrow$ or $\overline{HCS1} \uparrow$ to $\overline{IOCS16} \downarrow$		30		25	ns
IOCHL $\overline{IOR} \downarrow$ or $\overline{IOW} \downarrow$ to $\overline{IOCHRDY} \downarrow$		35		30	ns
ADRSET $\overline{HCS0}$ , A(2:0), A9/ $\overline{HCS1}$ setup to $\overline{IOR} \downarrow$ or $\overline{IOW} \downarrow$	25		25		ns
ADRHLD $\overline{HCS0}$ , A(2:0), A9/ $\overline{HCS1}$ hold from $\overline{IOR} \uparrow$ or $\overline{IOW} \uparrow$	10		5		ns

Note: Loading capacitance = 30 pF

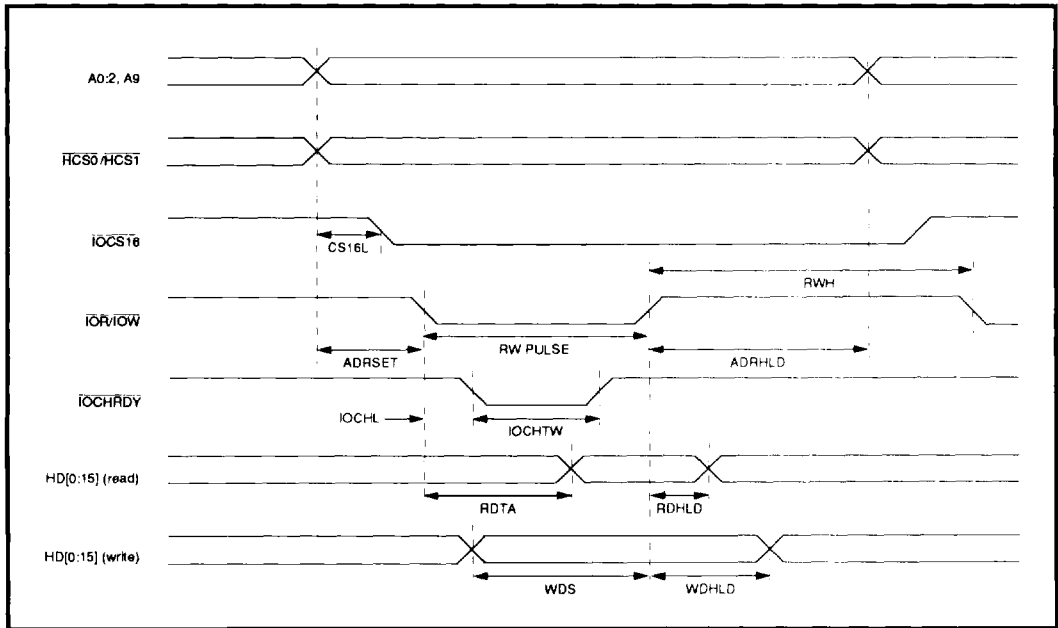
##### Functional Specification

PARAMETER	CONDITIONS	MIN	NOM	MAX	UNIT
IOCHTW $\overline{IOCHRDY}$ pulse width		0		5xBCLK	ns

**SSI 32C9301**  
**PC-AT Combo Controller**  
**With Reed Solomon, 3V Operation**



**FIGURE 15: Host Programmed I/O 8-16 Bit Timing**



**FIGURE 16: Host DMA 8-16 Bit Interface Timing (Non-demand mode)**

7

# SSI 32C9301 PC-AT Combo Controller With Reed Solomon, 3V Operation

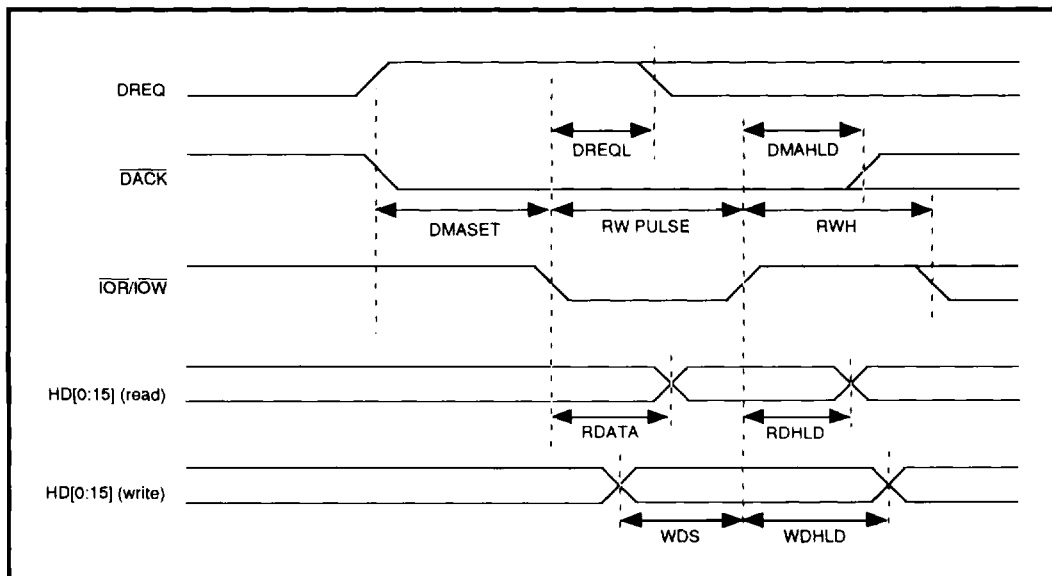


FIGURE 17: Host DMA 8/16-Bit Interface Timing (Demand Mode)

## RESET Assertion Timing Parameters (Figure 18)

PARAMETER	CONDITIONS	MIN	NOM	MAX	UNIT
Trpwl	$\overline{\text{RST}}$ pulse width low	NOT Power On Reset	500		ns
		Power On Reset	7.5		$\mu\text{s}$

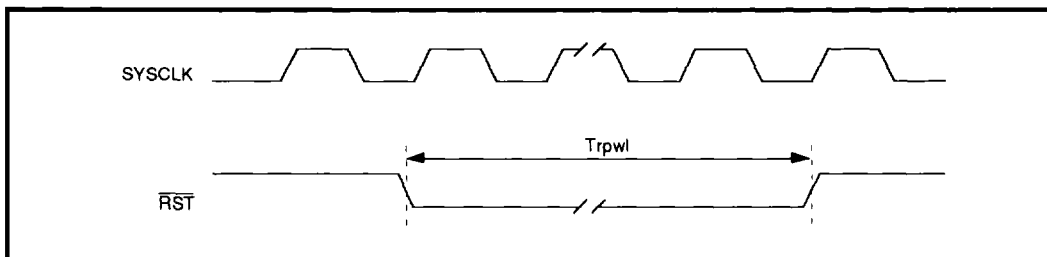
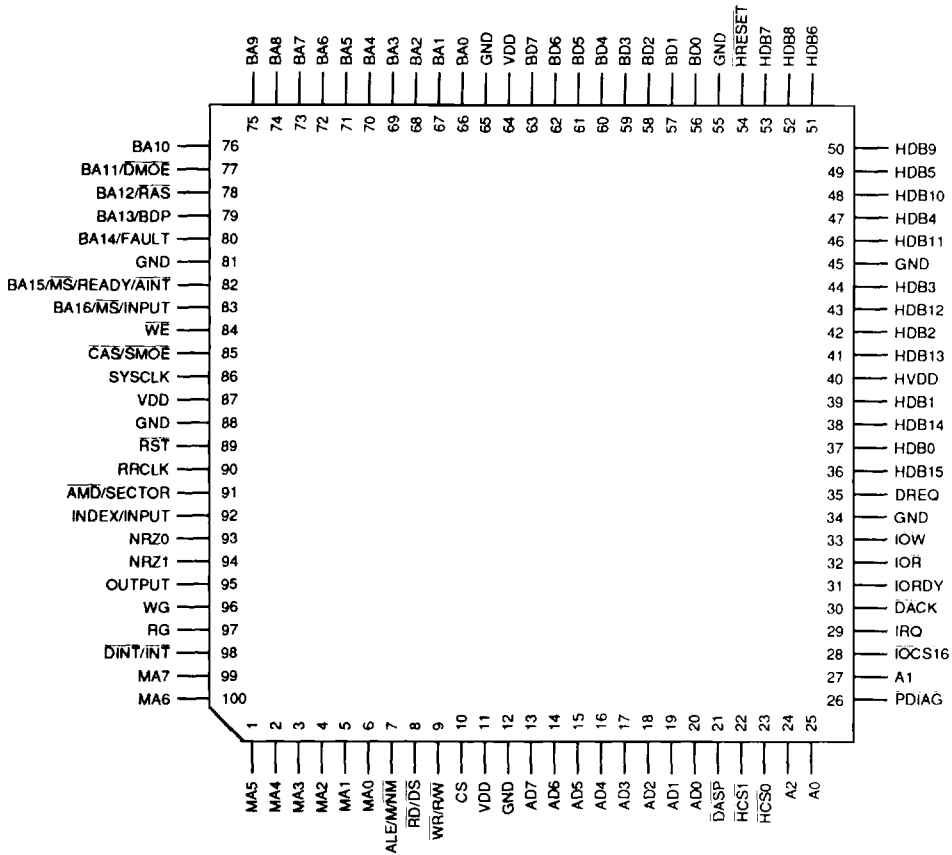


FIGURE 18: RESET Assertion Timing

# SSI 32C9301 PC-AT Combo Controller With Reed Solomon, 3V Operation

## PACKAGE PIN DESIGNATIONS (Top View)

CAUTION: Use handling procedures necessary for a static sensitive component.



### 100-Lead TQFP

**Advance Information:** Indicates a product still in the design cycle, and any specifications are based on design goals only. Do not use for final design.

No responsibility is assumed by Silicon Systems for use of this product nor for any infringements of patents and trademarks or other rights of third parties resulting from its use. No license is granted under any patents, patent rights or trademarks of Silicon Systems. Silicon Systems reserves the right to make changes in specifications at any time without notice. Accordingly, the reader is cautioned to verify that the data sheet is current before placing orders.

Silicon Systems, Inc., 14351 Myford Road, Tustin, CA 92680-7022 (714) 573-6000, FAX: (714) 573-6914

