

Memory Cards

Various high quality memory cards from ROHM products

ROHM offers many series of memory cards so that you can select specific memory card that best matches your system requirements, including size <full, 2/3 and half sizes> They have excellent environmental resistance, meaning that the cards can be used under severe temperature, humidity and dusty conditions. The cards can be plugged in/out many times and boast fast access time. The SRAM cards are equipped with source voltage detector which assures the data to be retained by the use of internal backup battery.

●ROHM's Custom Memory Cards

ROHM also offers custom memory cards. These function-intensive memory cards are developed in the sequence shown below. A variety of functions and configurations can be readily customized to cover the extensive needs of both consumer and industrial applications.

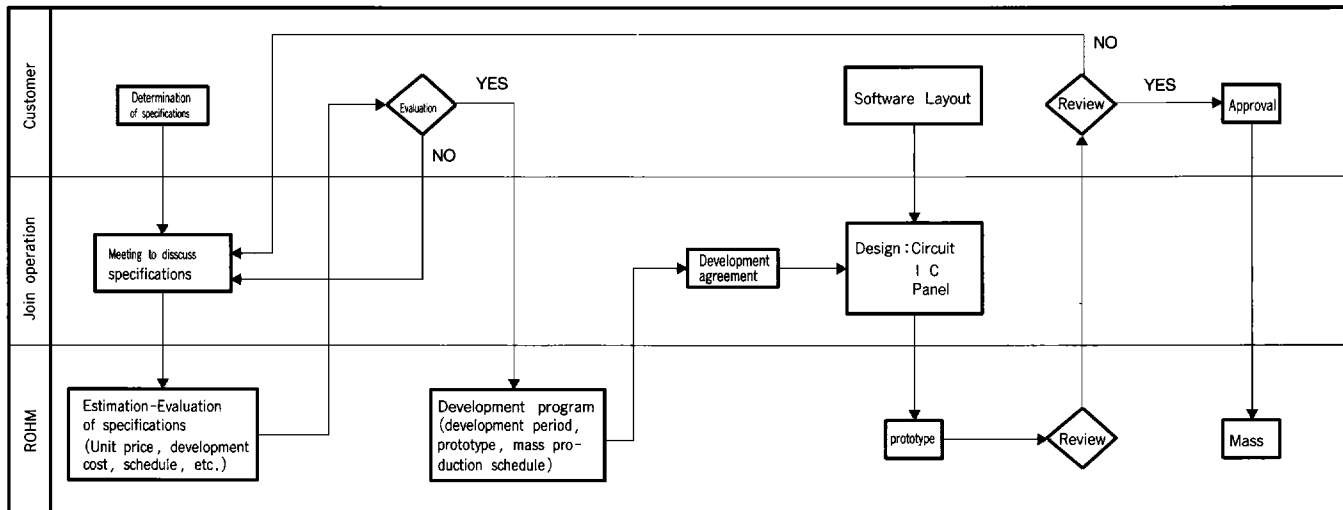

●Line Up

		Pin No.	Data width (bits)	Memory Capacity (Byte)													
				32K Byte	64K Byte	128K Byte	256K Byte	512K Byte	1M Byte	1.5M Byte	2M Byte	3M Byte	4M Byte	6M Byte		8M Byte	
MASK ROM	Full Size	68	16					RC-512J-MG RC-512J-MH RC-512J-MI	RC-M01J-MG RC-M01J-MH RC-M01J-MI	RC-F15J-MG RC-F15J-MH RC-F15J-MI	RC-M02J-MG RC-M02J-MH RC-M02J-MI	RC-M03J-MG RC-M03J-MH RC-M03J-MI	RC-M04J-MG ☆		RC-M08J-MG ☆	Note.1	
	Full Size (PCMCIA)	68	16/8					RC-512J-MB	RC-M01J-MB	RC-F15J-MB	RC-M02J-MB		RC-M04J-MB	RC-M06J-MB			
	Half Size (Z)	40	8					RC-512Z-MB	RC-M01Z-MB		RC-M02Z-MB						
OTP ROM	Full Size (PCMCIA)	68	16/8					RC-512J-QD	RC-M01J-QD	RC-F15J-QD	RC-M02J-QD	RC-M03J-QD					
FLASH	Full Size (PCMCIA)	68	16/8				RC-256J-EF	RC-512J-EF	RC-M01J-EF		RC-M02J-EF	RC-M03J-EF	RC-M04J-EF		☆		
	Half Size (Z)	40	8			RC-128Z-EB	RC-256Z-EB	RC-512Z-EB	RC-M01Z-EB								
	2/3 Size	45	8			RC-128W-EB	RC-256W-EB										
DRAM	Full Size	68	16									RC-M02J-DB		RC-M04J-DB	RC-M06J-DB		
	Half Size (Y)	40	16									RC-M02Y-DA		RC-M04Y-DA			
	Full Size	40	16						RC-M01J-DA		RC-M02J-DA		RC-M04J-DA		RC-M08J-DA		
SRAM	Half Size (PCMCIA)	68	16/8		RC-064J-SF	RC-128J-SF	RC-256J-SF	RC-512J-SF	RC-M01J-SF		☆	☆RC-M02J-SF					Note.2
	Half Size (Z)	40	8	RC-032Z-SB	RC-064Z-SB	RC-128Z-SB	RC-256Z-SB										
MODEM	Full Size (PCMCIA Ref 2 type II)	68															Note.4

Note:1.* Under development

2.Model name subscript:MG=no attribute, MH=8K-byte attribute, MI=attribute "FF" returned.

3.Model name subscript:SE=attribute 5 bytes fixed, SF=attribute 5 bytes fixed, SH=attribute 2 kbytes, SJ=attribute FF returned.

4.With FAX function (class 2)

●Product designation

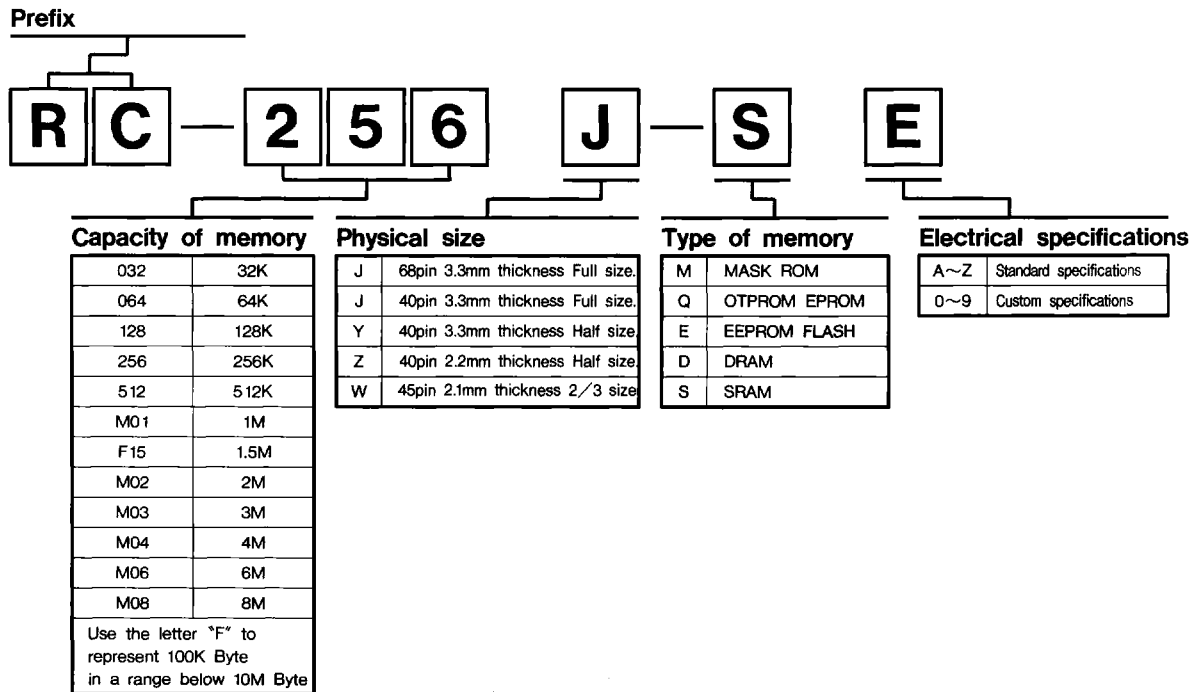

●MASK ROM

Application	Package	Pin count	Part No.	Capacity (K Byte)	Data width (bit)	Access Time (ns)
* Video game programs * Program memory (spread sheet, word processor, etc.) for PCs and hand-held computers, and data. * Dictionaries * Educational software * Font card for typewriters and printers.	Full size	68 Pin PCMCIA downward compatible	RC-5 12J-MG RC-5 12J-MH RC-5 12J-MI	512	16	200
			RC-M0 1J-MG RC-M0 1J-MH RC-M0 1J-MI	1024		
			RC-F 15J-MG RC-F 15J-MH RC-F 15J-MI	1536		
			RC-M02J-MG RC-M02J-MH RC-M02J-MI	2048		
			RC-M03J-MG RC-M03J-MH RC-M03J-MI	3072		
			RC-M04J-MG ☆RC-M04J-MH ☆RC-M04J-MI	4096		
	RC-M08J-MG ☆RC-M08J-MH ☆RC-M08J-MI	8192				
	Full size	68 Pin PCMCIA Release2	RC-5 12J-MB	512	8/16	250
			RC-M0 1J-MB	1024		
			RC-F 15J-MB	1536		
			RC-M02J-MB	2048		
			RC-M04J-MB	4096		
Half size Z Series	40 Pin	RC-5 12Z-MB	512	8	200	
		RC-M0 1Z-MB	1024			
		RC-M02Z-MB	2048			

Notes:1.☆Under development

2.Model name subscript :MG=no attribute, MH=8K-byte attribute, MI=attribute "FF" returned.

Memory Cards

● OTP ROM

Application	Package	Pin count	Part No.	Capacity (K Byte)	Data length (Bit)	Access time (ns)
* Program memory for personal computer, hand held computer, etc. * Electronic clinical charts	Full size	68 Pin PCMCIA: Release2	RC-512J-QD	512	8/16	250
			RC-M01J-QD	1024		
			RC-F15J-QD	1536		
			RC-M02J-QD	2048		
			RC-M03J-QD	3072		

● FLASH

Application	Package	Pin count	Part No.	Capacity (K Byte)	Data length (Bit)	Access time (ns)
* Image memory for electronic still cameras * Hard disc alternative for PCs. * Memory for electronic musical instruments. * Control program data storage for industrial equipment	Full size	68 Pin PCMCIA: Release2	RC-256J-EF	256	8/16	250
			RC-512J-EF	512		
			RC-M01J-EF	1024		
			RC-M02J-EF	2048		
			RC-M03J-EF	3072		
			RC-M04J-EF	4096		
		☆	8192			
	Half size Z Series	40 Pin	RC-128Z-EB	128	8	200
			RC-256Z-EB	256		
			RC-512Z-EB	512		
			RC-M01Z-EB	1024		
	2/3 Size	45 Pin	RC-128W-EB	128	8	200
			RC-256W-EB	256		

Note:1.☆:Under development

● SRAM

Application	Package	Pin count	Part No.	Capacity (K Byte)	Data length (Bit)	Access time (ns)
* Floppy disk alternative for PCs. * Commodity information storage for POS terminals. * Wave form storage for oscilloscopes.	Full size	68 Pin PCMCIA: Release2	RC-064J-SF	64	8/16	250
			RC-128J-SF	128		
			RC-256J-SF	256		
			RC-512J-SF	512		
			RC-M01J-SF	1024		
			☆	1536		
	☆RC-M02J-SF	2048				
	Half size Z Series	40 Pin	RC-032Z-SB	32	8	200
			RC-064Z-SB	64		
			RC-128Z-SB	128		
RC-256Z-SB			256			

Note:1.* Under development

2.Model name subscript:MG=no attribute, MH=8K-byte attribute, MI=attribute "FF" returned.

● DRAM

Application	Package	Pin count	Part No.	Capacity (K Byte)	Data length (Bit)	Access time (ns)
* Additional storage for PCs. * Temporary storage for facsimile. * Memory for Printer buffer.	Full Size	68 Pin	RC-M02J-DB	2048	16	100
			RC-M04J-DB	4096		
			RC-M06J-DB	6144		
	Half Size Y Series	40 Pin	RC-M02Y-DA	2048	16	100
			RC-M04Y-DA	4096		
	Full Size	40 Pin	RC-M01J-DA	1024	16	150
			RC-M02J-DA	2048		
			RC-M04J-DA	4096		
			RC-M08J-DA	8192		

Note:1.Verify attribute for model with subscript "DB".

● Dimensions

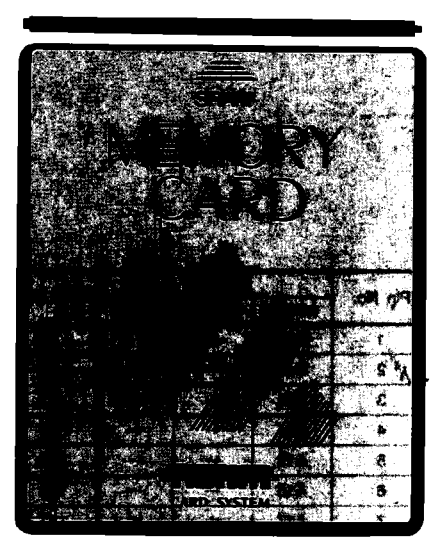
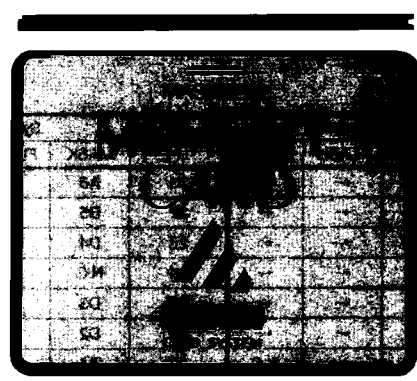
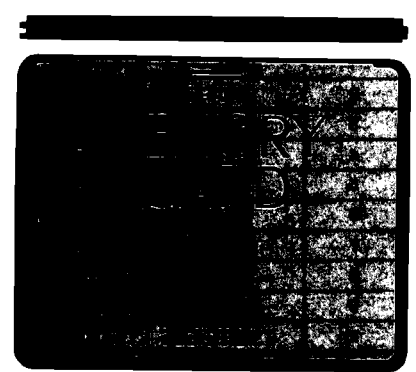
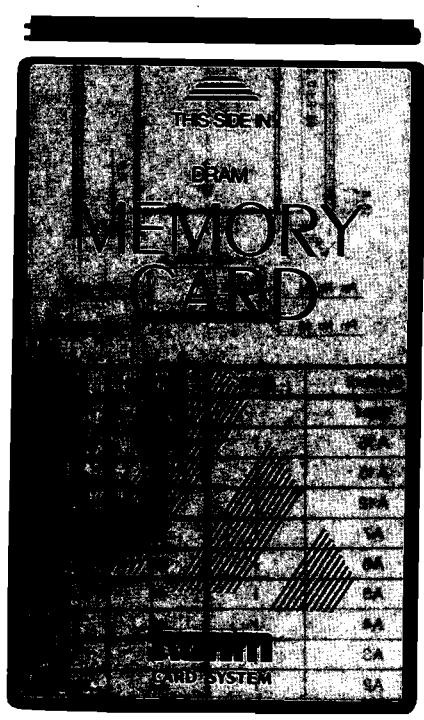
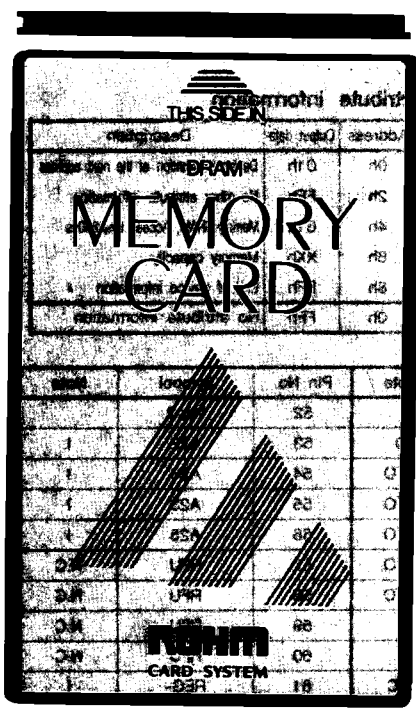

Memory Cards

●Dimensions and Pin Disposition

(Unit : mm)

Full Size 68Pin (PCMCIA Specification)

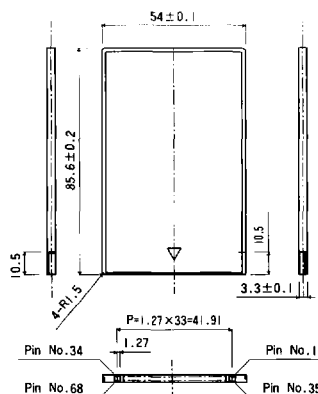

SF/SJ Attribute information

	Address	Output data	Description
SF	0h	01h	Device information at the next address
	2h	FFh	No other attribute information
	4h	61h	Memory SRAM, Access time:250ns
	6h	XXh	Memory capacity
	8h	FFh	End of device information
SJ	0h	FFh	No attribute information

Pin No.	Symbol	Note	Pin No.	Symbol	Note	Pin No.	Symbol	Note	Pin No.	Symbol	Note
1	GND		18	Vpp1		35	GND		52	Vpp2	
2	D3	I/O	19	A16	I	36	CD1-	O	53	A22	I
3	D4	I/O	20	A15	I	37	D11	I/O	54	A23	I
4	D5	I/O	21	A12	I	38	D12	I/O	55	A23	I
5	D6	I/O	22	A7	I	39	D13	I/O	56	A25	I
6	D7	I/O	23	A6	I	40	D14	I/O	57	RFU	N.C
7	CE1-	I	24	A5	I	41	D15	I/O	58	RFU	N.C
8	A10	I	25	A4	I	42	CE2-	I	59	RFU	N.C
9	OE-	I	26	A3	I	43	RFSH-	I	60	RFU	N.C
10	A11	I	27	A2	I	44	RFU	N.C	61	REG-	I
11	A9	I	28	A1	I	45	RFU	N.C	62	BVD2	O
12	A8	I	29	A0	I	46	A17	I	63	BVD1	O
13	A13	I	30	D0	I/O	47	A18	I	64	D8	I/O
14	A14	I	31	D1	I/O	48	A19	I	65	D9	I/O
15	WE-/PGM-	I	32	D2	I/O	49	A20	I	66	D10	I/O
16	RDY-/BSY-	O	33	WP	O	50	A21	I	67	CD2-	O
17	Vcc		34	GND		51	Vcc		68	GND	

Half Size 40 Pin (Z Series)

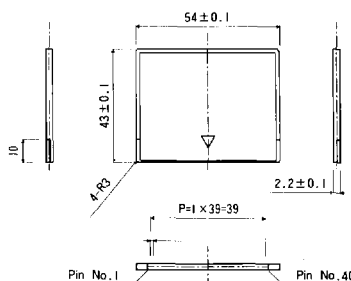

Pin No.	Symbol			Pin No.	Symbol			Pin No.	Symbol			Pin No.	Symbol		
	MASK	FLASH	SRAM		MASK	FLASH	SRAM		MASK	FLASH	SRAM		MASK	FLASH	SRAM
1	CA1	←	←	11	D6	←	←	21	A5	←	←	31	N.C	WE-	BWR-
2	Vss	←	←	12	A13	←	←	22	D5	←	←	32	OE-	←	←
3	Vdd	←	←	13	A12	←	←	23	D4	←	←	33	D1	←	←
4	A14	←	←	14	A11	←	←	24	N.C	←	DET-	34	D0	←	←
5	A15	←	←	15	A10	←	←	25	D3	←	←	35	CE-	←	←
6	A16	←	←	16	A9	←	←	26	D2	←	←	36	A19	←	N.C
7	A17	←	←	17	A18	←	N.C	27	A4	←	←	37	A20	N.C	N.C
8	N.C	←	LB-	18	A8	←	←	28	A3	←	←	38	Vdd	Vpp	Vdd
9	A0	←	←	19	A7	←	←	29	A2	←	←	39	Vss	←	←
10	D7	←	←	20	A6	←	←	30	A1	←	←	40	CA2	←	←

●Dimensions And Pin Dispositions

(Unit : mm)

Half Size 40Pin (Y Series)

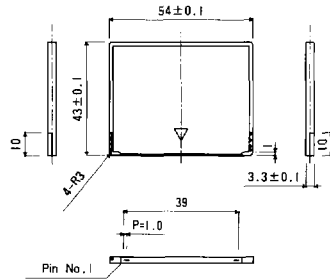

Pin No.	Symbol DRAM	Pin No.	Symbol DRAM	Pin No.	Symbol DRAM	Pin No.	Symbol DRAM
1	CD1-	11	GND	21	Vcc	31	A8
2	D3	12	CAS10-	22	A1	32	D0
3	D4	13	CAS11-	23	A2	33	D1
4	D5	14	RAS1-	24	A3	34	D2
5	D6	15	WE0-	25	A4	35	D11
6	D7	16	CAS00-	26	A5	36	D12
7	D8	17	CAS01-	27	A6	37	D13
8	D9	18	RAS0-	28	A7	38	D14
9	D10	19	A9	29	Vcc	39	D15
10	A0	20	WE1-	30	GND	40	CD2-

Full Size 40Pin

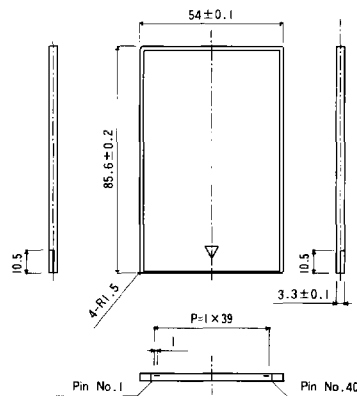

Pin No.	Symbol DRAM	Pin No.	Symbol DRAM	Pin No.	Symbol DRAM	Pin No.	Symbol DRAM
1	CD1-	11	GND	21	Vcc	31	A8
2	D3	12	CAS1-	22	A1	32	D0
3	D4	13	RAS3-	23	A2	33	D1
4	D5	14	RAS1-	24	A3	34	D2
5	D6	15	WE-	25	A4	35	D11
6	D7	16	CAS0-	26	A5	36	D12
7	D8	17	RAS2-	27	A6	37	D13
8	D9	18	RAS0-	28	A7	38	D14
9	D10	19	Vcc	29	GND	39	D15
10	A0	20	Vcc	30	GND	40	CD2-

Memory Cards

(Unit : mm)

2/3 Size 45Pin

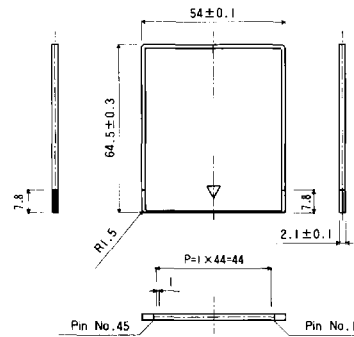

Pin No.	Symbol FLASH	Pin No.	Symbol FLASH	Pin No.	Symbol FLASH	Pin No.	Symbol FLASH
1	Vcc	13	A8	25	D3	37	N.C
2	N.C	14	A7	26	D4	38	N.C
3	N.C	15	A6	27	D5	39	A16
4	N.C	16	A5	28	D6	40	S1
5	Vpp	17	A4	29	D7	41	S2
6	A15	18	A3	30	CCE0-	42	N.C
7	A14	19	A2	31	N.C	43	N.C
8	A13	20	A1	32	CCE2-	44	N.C
9	A12	21	A0	33	N.C	45	GND
10	A11	22	D0	34	WE-		
11	A10	23	D1	35	OE-		
12	A9	24	D2	36	N.C		

Full Size 68Pin (DRAM)

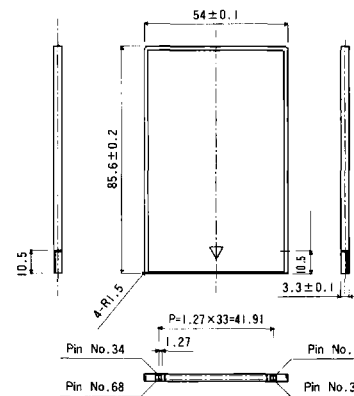

Pin No.	Symbol	Pin No.	Symbol	Pin No.	Symbol	Pin No.	Symbol
1	GND	18	N.C	35	GND	52	N.C
2	D3	19	CAS11-	36	CD1-	53	RAS2-
3	D4	20	CAS10-	37	D11	54	RAS3-
4	D5	21	N.C	38	D12	55	N.C
5	D6	22	A7	39	D13	56	N.C
6	D7	23	A6	40	D14	57	N.C
7	N.C	24	A5	41	D15	58	N.C
8	N.C	25	A4	42	N.C	59	N.C
9	N.C	26	A3	43	N.C	60	N.C
10	N.C	27	A2	44	N.C	61	N.C
11	A9	28	A1	45	N.C	62	N.C
12	A8	29	A0	46	CAS20-	63	N.C
13	N.C	30	D0	47	CAS21-	64	D8
14	N.C	31	D1	48	CAS30-	65	D9
15	WE-	32	D2	49	CAS31-	66	D10
16	N.C	33	N.C	50	RAS1-	67	CD2-
17	Vcc	34	GND	51	Vcc	68	GND