

INFRARED REMOTE CONTROL DECODERS

GENERAL DESCRIPTION

The main function of the SAA3009 and SAA3049 ICs is to check and convert the received coded data (RECS80/RC5) into latched binary outputs. The device address can be hard-wired for a particular address allowing several devices in one location. Alternatively, received data with any address can be accepted, the received data and address are then outputs.

Features

- Decodes 64 remote control commands with a maximum of 32 subaddresses
- Accepts RECS80 codes with pulse position modulation (SAA3004, SAA3007, SAA3008) or RC5 codes with biphase transmission (SAA3006, SAA3010)
- Available at SAA3009 with 8 high current (10 mA) open-drain outputs and internal pull-ups for direct LED drive via resistors or as SAA3049 for low supply current applications
- Adding circuitry for binary decoding allows a maximum of 2048 commands to be used, for example 1-of-16 decoder (HEF4515)

QUICK REFERENCE DATA

parameter	conditions	symbol	min.	typ.	max.	unit
Supply voltage						
SAA3009	note 1	V_{CC}	4.5	5.0	5.5	V
SAA3049	note 2	V_{CC}	2.5	—	5.5	V
Supply current						
SAA3009	note 1	I_{CC}	—	—	70	mA
SAA3049	note 2	I_{CC}	—	1.0	2.0	mA
Oscillator frequency		f_{osc}	—	4	—	MHz
Output sink current LOW (pins 1 to 8)						
SAA3009	note 3	I_{OL}	—	—	10	mA
SAA3049	note 4	I_{OL}	1.6	3.0	—	mA

Notes to the QUICK REFERENCE DATA

1. $T_{amb} = 0$ to $+70$ °C.
2. $T_{amb} = -40$ to $+85$ °C.
3. Open-drain with 20 to 50 k Ω internal pull-up resistor.
4. Open-drain without internal pull-up resistor at $V_{CC} = 5$ V \pm 10%; $V_O = 0.4$ V.

PACKAGE OUTLINES

SAA3009P; SAA3049P: 20 lead DIL; plastic (SOT146).
SAA3049T: 20 lead mini-pack; plastic (SO20; SOT163A).

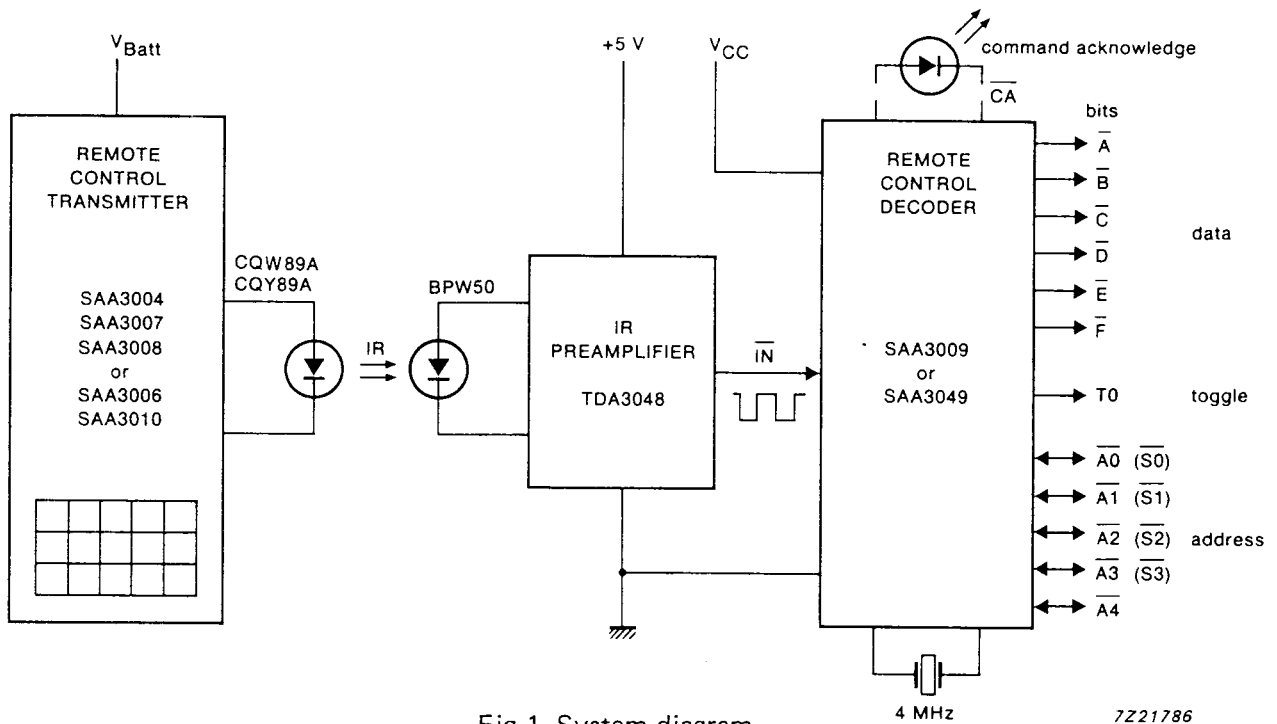

Fig.1 System diagram.

7221786

TRANSMITTERS (see individual data sheets for full specifications)

- SAA3004 $V_{Batt} = 4$ to 11 V (max.); $7 \times 64 = 448$ commands (RECS80 code)
- SAA3007 $V_{Batt} = 2$ to 6.5 V (max.); $20 \times 64 = 1280$ commands (RECS80 code)
- SAA3008 $V_{Batt} = 2$ to 6.5 V (max.); $20 \times 64 = 1280$ commands (RECS80 code)
- SAA3006 $V_{Batt} = 2$ to 7.0 V (max.); $32 \times 64 = 2048$ commands (RC5 code)
- SAA3010 $V_{Batt} = 2$ to 7.0 V (max.); $32 \times 64 = 2048$ commands (RC5 code)

RATINGS

Limiting values in accordance with the Absolute Maximum System (IEC 134)

parameter	symbol	min.	max.	unit
Supply voltage				
SAA3009	V_{CC}	-0.5	7.0	V
SAA3049	V_{CC}	-0.8	8.0	V
Input voltage (any pin)				
SAA3009	V_I	-0.5	7.0	V
SAA3049	V_I	-0.8	$V_{CC} + 0.8$	V
DC input/output current				
SAA3009 (pins 1 to 8)	$\pm I_I, \pm I_O$	—	20	mA
SAA3009 (all other pins)	$\pm I_I, \pm I_O$	—	10	mA
SAA3049 (any pin)	$\pm I_I, \pm I_O$	—	10	mA
Total power dissipation				
SAA3009	P_{tot}	—	1	W
SAA3049	P_{tot}	—	0.5	W
Operating ambient temperature range				
SAA3009	T_{amb}	0	+ 70	°C
SAA3049	T_{amb}	-40	+ 85	°C
Storage temperature range				
SAA3009	T_{stg}	-65	+ 150	°C
SAA3049	T_{stg}	-65	+ 150	°C

DEVELOPMENT DATA

CHARACTERISTICS

All voltages measured with respect to ground ($V_{EE} = 0$ V).

SAA3009: $V_{CC} = 4.5$ to 5.5 V; $T_{amb} = 0$ to $+70$ °C unless otherwise specified

SAA3049: $V_{CC} = 2.5$ to 5.5 V; $T_{amb} = -40$ to $+85$ unless otherwise specified

parameter	conditions	symbol	min.	typ.	max.	unit
Supply voltage						
SAA3009		V_{CC}	4.5	5.0	5.5	V
SAA3049		V_{CC}	2.5	—	5.5	V
Supply current						
SAA3009		I_{CC}	—	—	70	mA
SAA3049		I_{CC}	—	0.8	2.0	mA
Input signals (pin 9)						
Input voltage HIGH						
SAA3009		V_{IH}	2.0	—	$V_{CC} + 0.5$	V
SAA3049		V_{IH}	$0.7 V_{CC}$	—	V_{CC}	V
Input voltage LOW	active					
SAA3009		V_{IL}	0.5	—	0.8	V
SAA3049		V_{IL}	0	—	$0.3 V_{CC}$	V
Mode selection (pin 11)						
Input voltage HIGH	note 1					
SAA3009		V_{IH}	2.0	—	$V_{CC} + 0.5$	V
SAA3049		V_{IH}	$0.7 V_{CC}$	—	V_{CC}	V
Input voltage LOW	note 2					
SAA3009		V_{IL}	-0.5	—	0.8	V
SAA3049		V_{IL}	0	—	$0.3 V_{CC}$	V
Command received indicator and mode control (pin 19)	note 3					
Input voltage HIGH						
SAA3009		V_{IH}	3.0	—	$V_{CC} + 0.5$	V
SAA3049		V_{IH}	$0.7 V_{CC}$	—	V_{CC}	V
Input voltage LOW						
SAA3009		V_{IL}	-0.5	—	1.5	V
SAA3049		V_{IL}	0	—	$0.3 V_{CC}$	V
Crystal oscillator						
Oscillator frequency	note 4	f_{osc}	—	4	—	MHz

parameter	conditions	symbol	min.	typ.	max.	unit
SAA3009 OUTPUTS						
10 mA open-drain with internal pull-up resistor (pins 1 to 8)						
Output voltage HIGH	$I_{OH} = -50 \mu A$	V_{OH}	2.4	—	V_{CC}	V
Output voltage LOW	$I_{OL} = 10 \text{ mA}$	V_{OL}	—	—	1.0	V
Output sink current LOW		I_{OL}	—	—	10	mA
5 mA open-drain without internal pull-up resistor (pins 18 and 19)						
Output voltage HIGH		V_{OH}	—	—	V_{CC}	V
Output voltage LOW	$I_{OL} = 5 \text{ mA}$	V_{OL}	—	—	0.45	V
Output sink current LOW		I_{OL}	—	—	5	mA
1.6 mA open-drain with internal pull-up resistor (pins 15, 16 and 17)						
Output voltage HIGH		V_{OH}	—	—	V_{CC}	V
Output voltage LOW	$I_{OL} = 1.6 \text{ mA}$	V_{OL}	—	—	0.45	V
Output sink current LOW		I_{OL}	—	—	1.6	mA
SAA3049 OUTPUTS						
Open-drain without internal pull-up resistor						
Output sink current LOW	note 5 $V_{CC} = 5 \text{ V} \pm 10\%$; $V_{OL} = 0.4 \text{ V}$	I_{OL}	1.6	3.0	—	mA

Notes to the characteristics

1. RECS80 decoder for transmitters SAA3004, SAA3007 or SAA3008; SAA3009 has an internal pull-up resistor.
2. RC5 decoder for transmitters SAA3006 or SAA3010.
3. With pin 19 = HIGH, then pins 7, 8, 15, 16 and 17 are address inputs.
With pin 19 = LOW, then pins 7, 8, 15, 16 and 17 are 4 or 5 address received outputs.

In Figs 4, 5 and 6 this HIGH/LOW switching is dependent on whether the transistor on pin 19 is fed via a series resistor or not. In both applications pin 19, which toggles several times (see Fig.3) while a valid command is acknowledged, can be used to activate (flash) an LED indicator.

4. A quartz crystal with a frequency of 4 MHz is recommended for the standard transmitter application.
4. Application as output requires connection of an external pull-up resistor.

CHARACTERISTICS (continued)

Reset (pin 14)

The simple circuit is shown in Figs 4, 5 and 6. The alternative reset circuit shown in Fig.2 protects against short term power supply transients by generating a reset.

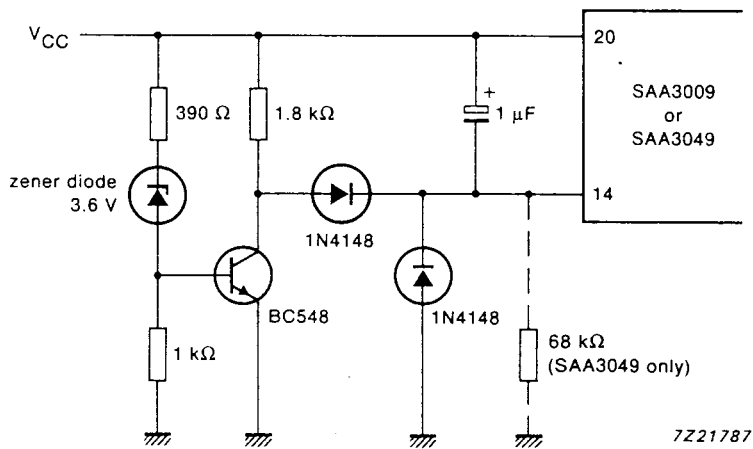

Fig.2 Proposed improved reset circuit.

Infrared signal input (pin 9)

This pin is sensitive to a negative-going edge.

Command received indicator (pin 19)

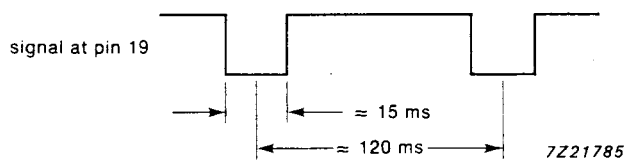
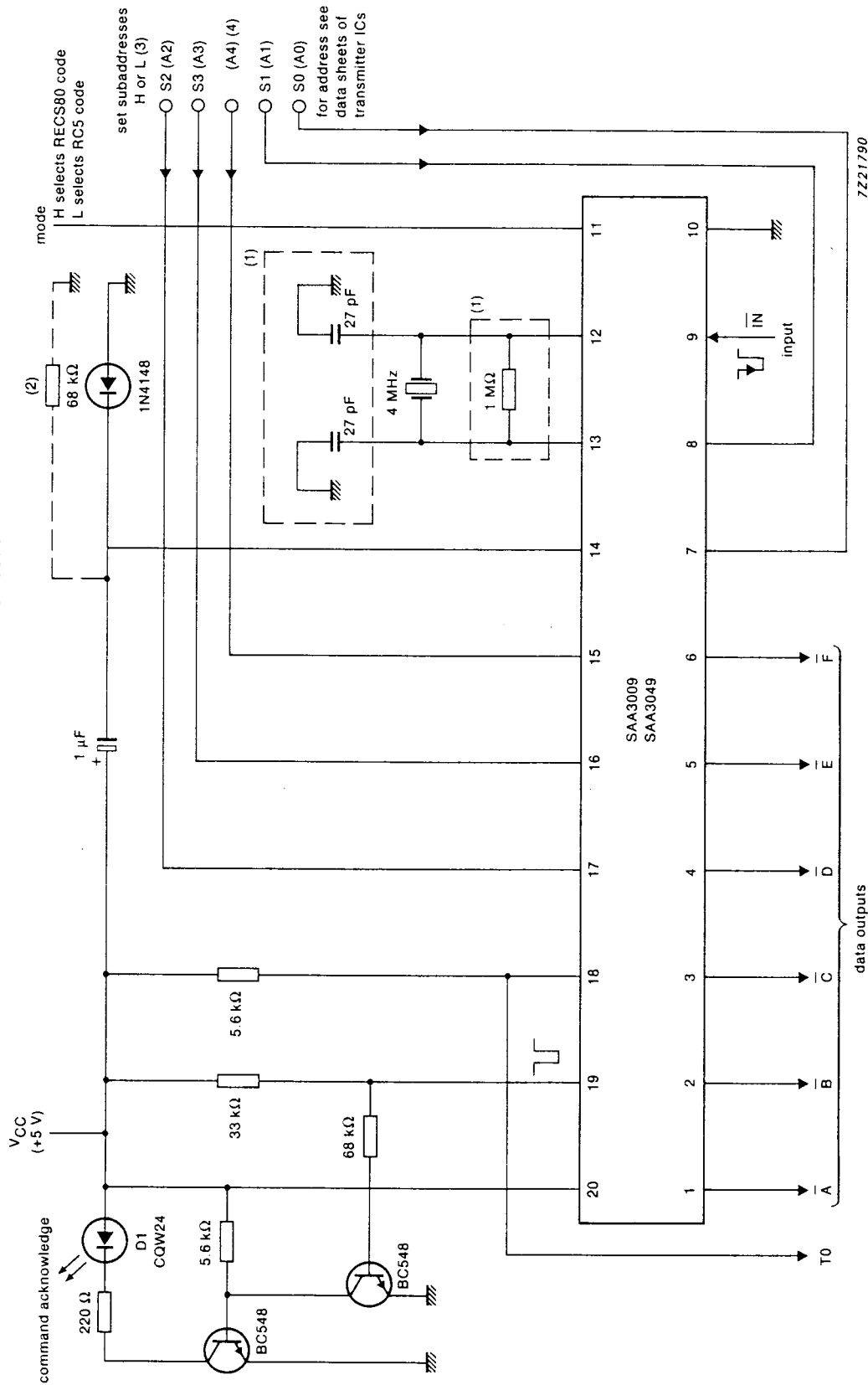

Fig.3 Output diagram of command acknowledge.



- (1) only for SAA3009.
- (2) only for SAA3049.
- (3) address inputs:
 - when LOW address input pin is connected to ground
 - when HIGH address input pin is open (SAA3009)
 - when HIGH address input pin is connected via pull-up resistor to V_{CC} (SAA3049)
- (4) subaddress range RECS80 code:
 - when LOW (subaddress 8 to 20) pin 15 is connected to ground
 - when HIGH (subaddress 1 to 7) pin 15 is open (SAA3009)
 - when HIGH (subaddress 1 to 7) pin 15 is connected via pull-up resistor to V_{CC} (SAA3049)

Fig.6 Remote control decoder for up to 20 subaddresses with 6 + 1-bit parallel outputs (RECS80 code). Decoder is set for required subaddress by holding address pins HIGH or LOW. Pin 11 is HIGH for use with transmitter types SAA3004, SAA3007 or SAA3008 (RECS80 code). Pin 11 is LOW for use with transmitter types SAA3006 or SAA3010 (RC5 code). Remote control decoder for up to 32 subaddresses with 6 + 1-bit parallel outputs (RC5 code).