

To our customers,

Old Company Name in Catalogs and Other Documents

On April 1st, 2010, NEC Electronics Corporation merged with Renesas Technology Corporation, and Renesas Electronics Corporation took over all the business of both companies. Therefore, although the old company name remains in this document, it is a valid Renesas Electronics document. We appreciate your understanding.

Renesas Electronics website: <http://www.renesas.com>

April 1st, 2010
Renesas Electronics Corporation

Issued by: Renesas Electronics Corporation (<http://www.renesas.com>)

Send any inquiries to <http://www.renesas.com/inquiry>.

Not recommended
for new design

Notice

1. All information included in this document is current as of the date this document is issued. Such information, however, is subject to change without any prior notice. Before purchasing or using any Renesas Electronics products listed herein, please confirm the latest product information with a Renesas Electronics sales office. Also, please pay regular and careful attention to additional and different information to be disclosed by Renesas Electronics such as that disclosed through our website.
2. Renesas Electronics does not assume any liability for infringement of patents, copyrights, or other intellectual property rights of third parties by or arising from the use of Renesas Electronics products or technical information described in this document. No license, express, implied or otherwise, is granted hereby under any patents, copyrights or other intellectual property rights of Renesas Electronics or others.
3. You should not alter, modify, copy, or otherwise misappropriate any Renesas Electronics product, whether in whole or in part.
4. Descriptions of circuits, software and other related information in this document are provided only to illustrate the operation of semiconductor products and application examples. You are fully responsible for the incorporation of these circuits, software, and information in the design of your equipment. Renesas Electronics assumes no responsibility for any losses incurred by you or third parties arising from the use of these circuits, software, or information.
5. When exporting the products or technology described in this document, you should comply with the applicable export control laws and regulations and follow the procedures required by such laws and regulations. You should not use Renesas Electronics products or the technology described in this document for any purpose relating to military applications or use by the military, including but not limited to the development of weapons of mass destruction. Renesas Electronics products and technology may not be used for or incorporated into any products or systems whose manufacture, use, or sale is prohibited under any applicable domestic or foreign laws or regulations.
6. Renesas Electronics has used reasonable care in preparing the information included in this document, but Renesas Electronics does not warrant that such information is error free. Renesas Electronics assumes no liability whatsoever for any damages incurred by you resulting from errors in or omissions from the information included herein.
7. Renesas Electronics products are classified according to the following three quality grades: “Standard”, “High Quality”, and “Specific”. The recommended applications for each Renesas Electronics product depends on the product’s quality grade, as indicated below. You must check the quality grade of each Renesas Electronics product before using it in a particular application. You may not use any Renesas Electronics product for any application categorized as “Specific” without the prior written consent of Renesas Electronics. Further, you may not use any Renesas Electronics product for any application for which it is not intended without the prior written consent of Renesas Electronics. Renesas Electronics shall not be in any way liable for any damages or losses incurred by you or third parties arising from the use of any Renesas Electronics product for an application categorized as “Specific” or for which the product is not intended where you have failed to obtain the prior written consent of Renesas Electronics. The quality grade of each Renesas Electronics product is “Standard” unless otherwise expressly specified in a Renesas Electronics data sheets or data books, etc.
 - “Standard”: Computers; office equipment; communications equipment; test and measurement equipment; audio and visual equipment; home electronic appliances; machine tools; personal electronic equipment; and industrial robots.
 - “High Quality”: Transportation equipment (automobiles, trains, ships, etc.); traffic control systems; anti-disaster systems; anti-crime systems; safety equipment; and medical equipment not specifically designed for life support.
 - “Specific”: Aircraft; aerospace equipment; submersible repeaters; nuclear reactor control systems; medical equipment or systems for life support (e.g. artificial life support devices or systems), surgical implantations, or healthcare intervention (e.g. excision, etc.), and any other applications or purposes that pose a direct threat to human life.
8. You should use the Renesas Electronics products described in this document within the range specified by Renesas Electronics, especially with respect to the maximum rating, operating supply voltage range, movement power voltage range, heat radiation characteristics, installation and other product characteristics. Renesas Electronics shall have no liability for malfunctions or damages arising out of the use of Renesas Electronics products beyond such specified ranges.
9. Although Renesas Electronics endeavors to improve the quality and reliability of its products, semiconductor products have specific characteristics such as the occurrence of failure at a certain rate and malfunctions under certain use conditions. Further, Renesas Electronics products are not subject to radiation resistance design. Please be sure to implement safety measures to guard them against the possibility of physical injury, and injury or damage caused by fire in the event of the failure of a Renesas Electronics product, such as safety design for hardware and software including but not limited to redundancy, fire control and malfunction prevention, appropriate treatment for aging degradation or any other appropriate measures. Because the evaluation of microcomputer software alone is very difficult, please evaluate the safety of the final products or system manufactured by you.
10. Please contact a Renesas Electronics sales office for details as to environmental matters such as the environmental compatibility of each Renesas Electronics product. Please use Renesas Electronics products in compliance with all applicable laws and regulations that regulate the inclusion or use of controlled substances, including without limitation, the EU RoHS Directive. Renesas Electronics assumes no liability for damages or losses occurring as a result of your noncompliance with applicable laws and regulations.
11. This document may not be reproduced or duplicated, in any form, in whole or in part, without prior written consent of Renesas Electronics.
12. Please contact a Renesas Electronics sales office if you have any questions regarding the information contained in this document or Renesas Electronics products, or if you have any other inquiries.

(Note 1) “Renesas Electronics” as used in this document means Renesas Electronics Corporation and also includes its majority-owned subsidiaries.

(Note 2) “Renesas Electronics product(s)” means any product developed or manufactured by or for Renesas Electronics.

M59330P

LAN Transceiver

REJ03F0032-0100Z

Rev.1.0

Sep.16.2003

Description

The M59330P is an integrated circuit for two-line LAN transceivers, conforming to J1850 specifications.

The chip incorporates bus line anomaly detection functions; anomalous behavior causes the ERR signal to go to "L". A selector causes a normal bus signal to be output to R_X.

By setting the standby signal to "L", a low consumption current state is maintained. At this time, the drivers BUS (+) and BUS (-) are both turned off.

In standby mode, on input of "H" level to the ERR pin, error output reset occurs.

Features

- Conforms to SAE J1850 specifications
- Internal bus line anomaly detection function

Applications

- LAN transceiver for automotive use, generic LAN transceiver, transceiver for other communication applications

Block Diagram

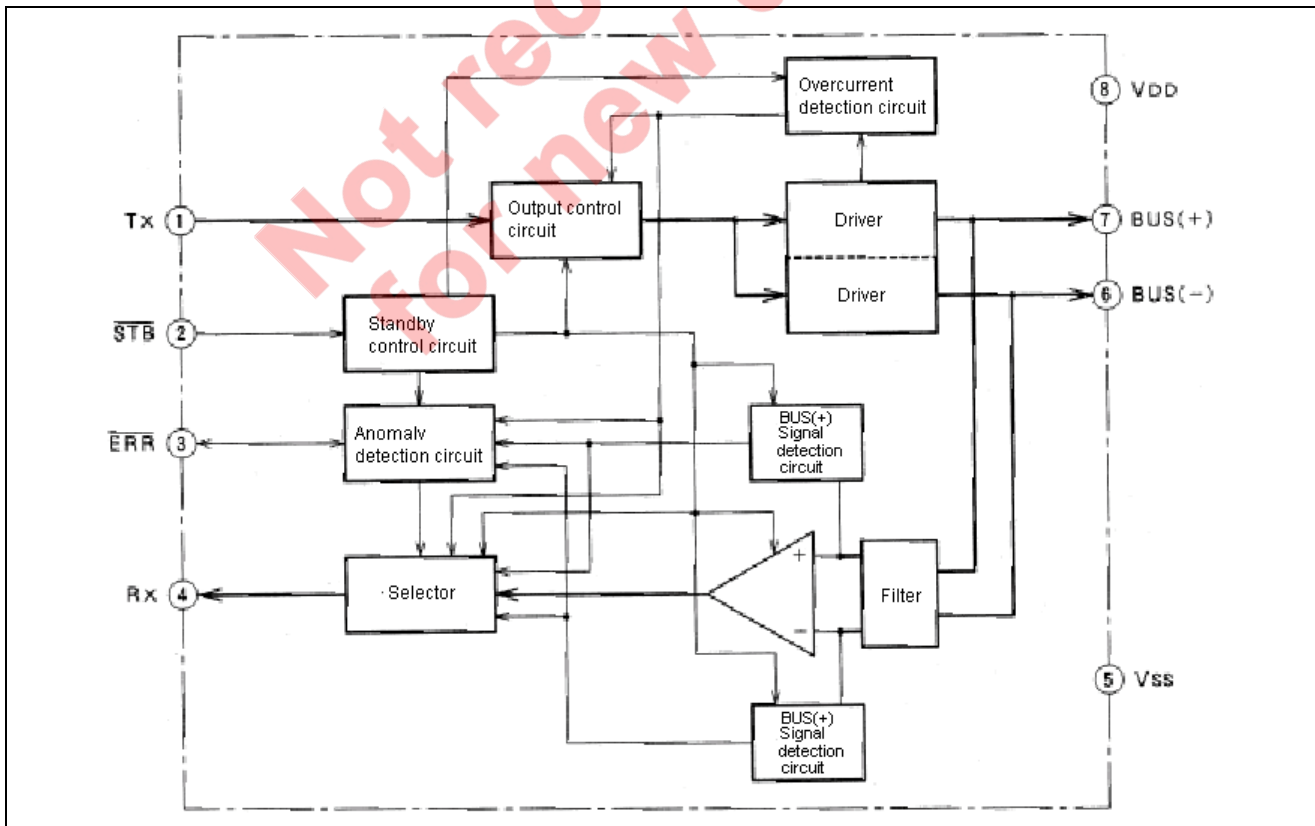

Pin Configuration (Top View)

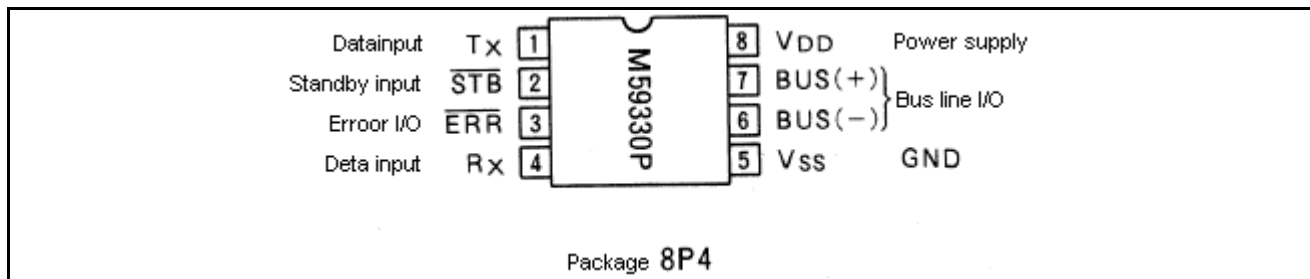

Explanation of Functions

Pin Description

Pin no.	Pin name	I/O	Function
1	Tx	I	Data signal input pin
2	STB	I	Standby signal input pin; L: standby mode, H: normal operation
3	ERR	I/O	Error signal output pin and error reset input pin; on detection of anomaly in transmission channel, outputs "L" level; in standby mode, error reset on input of "H" level
4	Rx	O	Pin for output of signal from transmission channel
5	Vss	I	Clamping pin
6	Bus(-)	I/O	Pin for signal output to transmission channel and for input of signal from transmission channel (negative logic)
7	Bus(+)	I/O	Pin for signal output to transmission channel and for input of signal from transmission channel (positive logic)
8	V _{DD}	I	Power supply pin

Transmission Channel Anomaly Detection and Communication Functions

The M59330P uses driver overcurrent detection functions and transmission signal logic error detection functions to detect anomalies in the transmission channel, and outputs an error signal (ERR (pin 3) = "L") accordingly. Also, by switching the signal output to pin R_x (pin 4) according to the anomalous state, communication is possible after anomaly occurrence.

(1) Overcurrent detection

The drivers of the BUS(+) pin (pin 7) and BUS(-) pin (pin 6) of the M59330P are provided with overcurrent detection circuits. When excessive current flows in a driver, the driver is turned off, and an error signal (ERR (pin 3) = "L") is output. When overcurrent is detected, the driver is maintained in the off state until error reset.

The drivers for the BUS(+) pin (pin 7) and the BUS(-) pin (pin 6) are independent; depending on the circumstances of the anomaly, both may be turned off.

A filter is incorporated to prevent erroneous operation due to transient currents when a driver is turned on, and an overcurrent state is not detected for a short period of time (several hundred ns). The detection current is set at approx. 180 mA.

(2) Logical anomaly detection

M59330P transmission signals operate at opposite phases, and by comparing the signals, anomalies in the transmission channel are detected. The signals are compared at a preset time relative to an edge of the signals of the transmission channels (BUS(+) , BUS(-)), and if they do not coincide, it is assumed that an anomaly has occurred in one of the transmission channels, and an error signal (ERR (pin 3) = "L") is output. When the next edge is detected within the preset time, this edge is taken as a new reference for timing, and if noncoincidence continues for longer than the preset time, an anomaly is detected. The time is set to approx. 4.2 μs.

Logical anomaly detection does not support multiple error modes.

When only a logical anomaly is detected, the driver is not turned off. A driver is turned off upon anomaly detection only when overcurrent is detected.

(3) Communication functions

The M59330P normally outputs differential signals on BUS (+) (pin 7) and BUS (-) (pin 6), but when an anomaly is detected, switches signal output to the R_X pin (pin 4) according to the anomaly state.

When overcurrent is detected, an anomaly with the driver or transmission channel for which the overcurrent was detected is assumed, and an error signal is output; at the same time, the signal for the other transmission channel is output to the R_X output (pin 4). As explained in (1) above, in some cases both drivers may be turned off; in such cases, the R_X output (pin 4) is fixed at "L".

When a logical anomaly is detected, an error signal (ERR (pin 3) = "L") is output, and at the same time the R_X output (pin 4) is driven to "L". After error signal output, a transmission channel for which a transmission signal edge is detected is regarded as normal, and the signal for the channel is output to the R_X output (pin 4).

Overcurrent detection takes precedence over logical anomaly detection in operations to switch the error signal output and R_X output.

Table 1. Anomaly modes and anomaly detection functions

	Anomaly mode		Error output	Communication after anomaly detection	Method of anomaly detection
1	Bus(+)	GND short	Y	Y	(2)
2		VDD short	Y	Y	(1), (2)
3		Open	Y	Y	(2)
4	Bus(-)	GND short	Y	Y	(1), (2)
5		VDD short	Y	Y	(2)
6		Open	Y	Y	(2)
6	BUS(+), BUS(-) short		Y	N	(1)

Error Reset

After standby mode is entered (the STB pin (pin 2) = "L"), the M59330P error output is reset by inputting level "H" to the ERR pin (pin 3). In this case, all operations relating to anomaly detection, such as overcurrent detection and R_X output switching, are canceled.

Standby Mode

By driving the STB pin (pin 2) to "L" level, the M59330P can be put into a low consumption current mode.

In standby mode, the driver and overcurrent detection functions do not operate, but the logical anomaly detection function continues to operate, and except for overcurrent detection, detection of anomalies is possible. However, there is only error signal output, and R_X output signal switching is not performed.

In standby mode, the R_X output is the logical sum of the BUS(+) signal and the BUS(-) signal.

Input/Output Equivalent Circuits

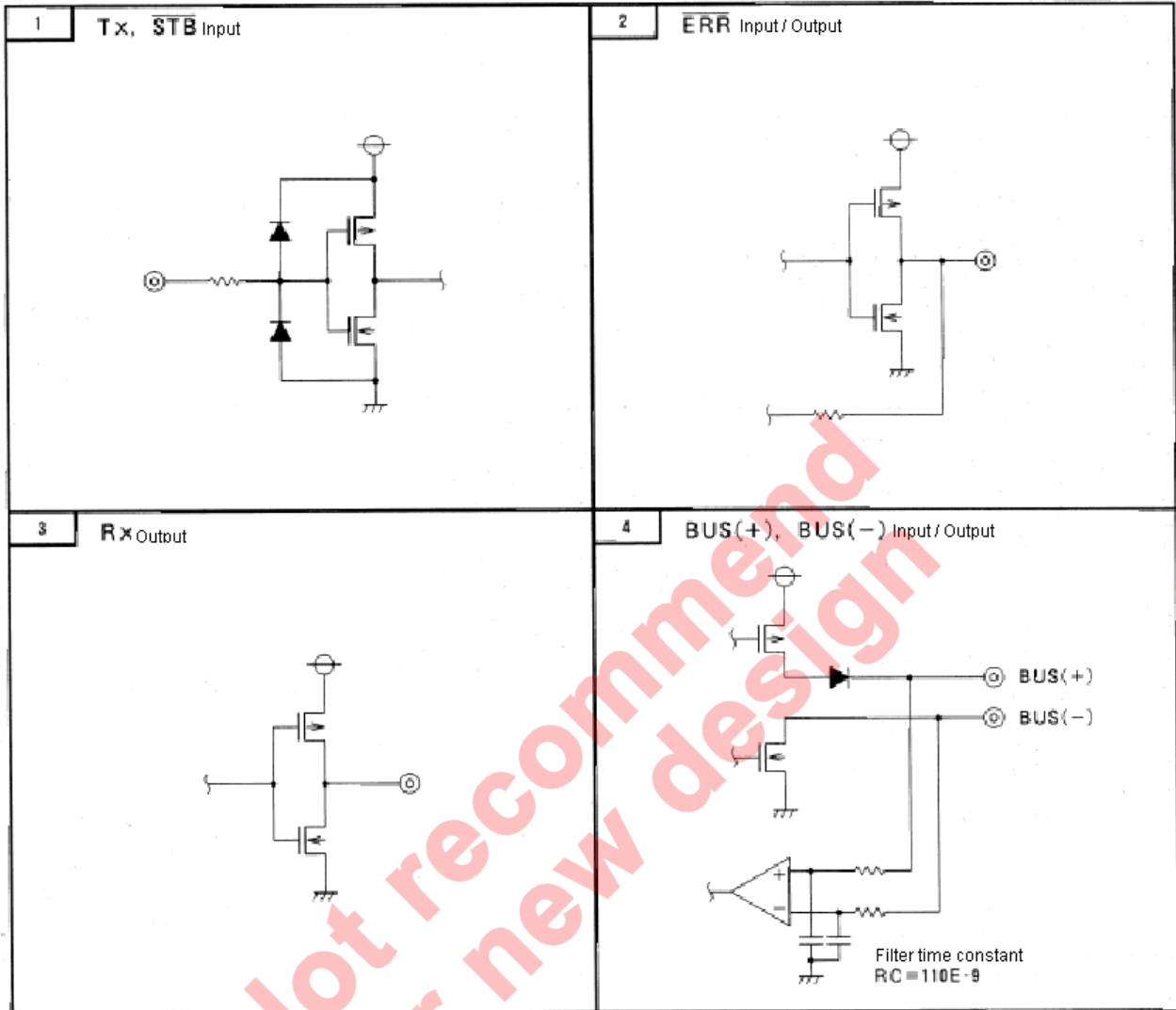

Not recommended for new design

Electrical Characteristics

(unless otherwise noted, Ta=-40 to 85°C)

Symbol	Quantity	Conditions	Rated value			Unit
			Min.	Typ.	Max.	
I _{DD1}	Power supply current 1	RBUS = 105 Ω, Tx = "L", STB = "H"			5.0	mA
I _{DD2}	Power supply current 2	RBUS = 105 Ω, Tx = "H", STB = "H"			55	mA
I _{DD3}	Power supply current 3	RBUS = 105 Ω, Tx = STB = "H"			200	μA
V _{TH1}	"H" input threshold voltage 1	ERR	2.2		3.2	V
V _{TH2}	"H" input threshold voltage 2	Tx, STB	2.3		3.5	V
V _{TL}	"L" input threshold voltage	Tx, STB	1.6		2.8	V
V _{HYSL}	Hysteresis width	Tx, STB	0.4		1.0	V
V _{CIN}	BUS input voltage range	BUS(+), BUS(-)	V _{SS}		V _{DD} -2.0	V
V _{HYS8}	Input hysteresis width	BUS(+), BUS(-) differential input	70		300	mV
I _{IPP1}	BUS(+) leakage current 1	with power supply off (V _{DD} = 0V), BUS(+) = 0V			100	μA
I _{IPP1}	BUS(+) leakage current 2	with power supply off (V _{DD} = 0V), BUS(+) = 5V			100	μA
I _{IPP2}	BUS(+) leakage current 3	with power supply on BUS(-) = 5V	-20			μA
I _{IDP2}	BUS(+) leakage current 4	with power supply on BUS(-) = 0V			100	μA
I _{IPM1}	BUS(-) leakage current 1	with power supply off -50mA			100	μA
I _{IDM1}	BUS(-) leakage current 2	with power supply off +50mA			100	μA
I _{IPM2}	BUS(-) leakage current 3	with power supply on			20	μA
V _{IDM2}	BUS(-) leakage current 4	with power supply on			100	μA
V _{DROP1}	Driver drop voltage	IBUS(+) = -50mA			1.0	V
V _{DROP2}		IBUS(-) = +50mA			0.6	
V _{OH1}	"H" output voltage 1	R _x pin I _{OH} = -1mA	4.5		5.0	V
V _{OL1}	"L" output voltage 1	R _x pin I _{OL} = +1mA			0.6	V
V _{OH2}	"H" output voltage 2	ERR pin I _{OH} = -1mA	4.5		5.0	V
IPD	ERR pull-down current	ERR pin V _{OH} = 3.0V		350	700	μA
C ₁₁	Input capacitance 1	power supply OFF (V _{DD} = 0V)			150	pF
C ₁₂	Input capacitance 2	power supply ON			150	pF
V _{TH1}	Ground offset voltage	across two nodes			1.0	V

Absolute Maximum Ratings

(unless otherwise noted, Ta = -40 to 85°C)

Symbol	Quantity	Conditions	Rated value			Unit
			Min.	Typ.	Max.	
V _{DD}	Power supply voltage		-0.3	6.5		V
V _I	Input voltage		-0.3	V _{DD} +0.3		V
V _O	Output voltage		-0.3	V _{DD} +0.3		V
I _O	Driver output current	BUS(+)			50	mA
		BUS(-)	-50			
P _{mex}	Allowable power consumption				200	mW
T _{stg}	Storage temperature		-50		125	°C

Note: All voltages use the circuit V_{SS} pin as reference; maximum and minimum values are absolute values; and currents are positive when flowing into a circuit, and negative (preceded by a minus sign) when flowing outward.

Recommended Operating Conditions

(unless otherwise noted, Ta = -40 to 85°C)

Symbol	Quantity	Conditions	Rated value			Unit
			Min.	Typ.	Max.	
V _{DD}	Power supply voltage		4.75		5.25	V
RBUS	BUS resistance	transmission rate = 41.6Kbps	105			Ω
		transmission rate = 125Kbps	105			
CBUS	BUS capacitance	transmission rate = 41.6Kbps RBUS = 378 Ω			10000	pF
		transmission rate = 125Kbps, RBUS = 378 Ω			3000	
Topr	Operating ambient temperature		-40		85	°C

Timing Characteristics

(unless otherwise noted, Ta = 25°C, V_{DD}=5.0 V, during normal operation)

Symbol	Quantity	Conditions	Rated value			Unit
			Min.	Typ.	Max.	
T _{dTBr}	T _X → BUS output delay time	CBUS = 10000pF, RBUS = 378 Ω transmission rate =41.6Kbps		0.25		μs
T _{dTRr}	T _X → R _X rise delay time	CBUS = 10000pF, RBUS = 378 Ω transmission rate =41.6Kbps		0.6		μs
T _{dBRf}	T _X → R _X fall delay time	CBUS = 10000pF, RBUS = 378 Ω transmission rate =41.6Kbps		3.0		μs
T _{dBRr}	BUS → R _X rise delay time	transmission rate = 41.6Kbps		0.35		μs
T _{dBRf}	BUS → R _X fall delay time	transmission rate = 41.6Kbps		0.33		μs
T _{WS}	Minimum STB input pulse width	standby mode	3.0			μs
T _{sS}	STB input setup time	on error reset	1.0			μs
T _{hS}	STB input hold time	on error reset	100			ns
T _{WE}	ERR input pulse width	on error reset	200			ns

Timing Charts

Timing Waveforms

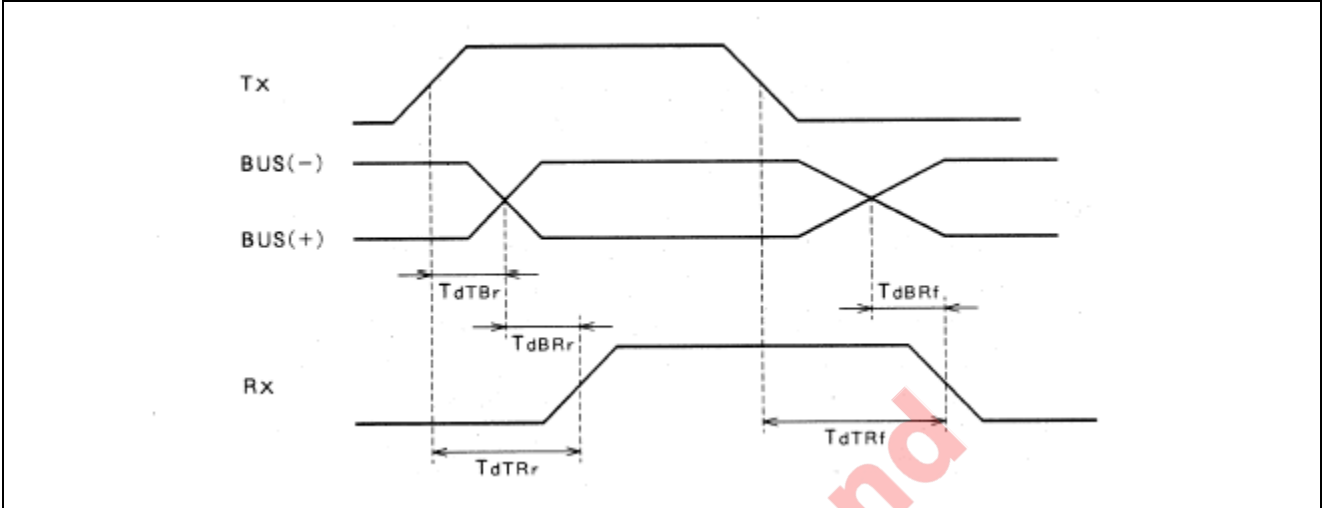

Error Reset Timing

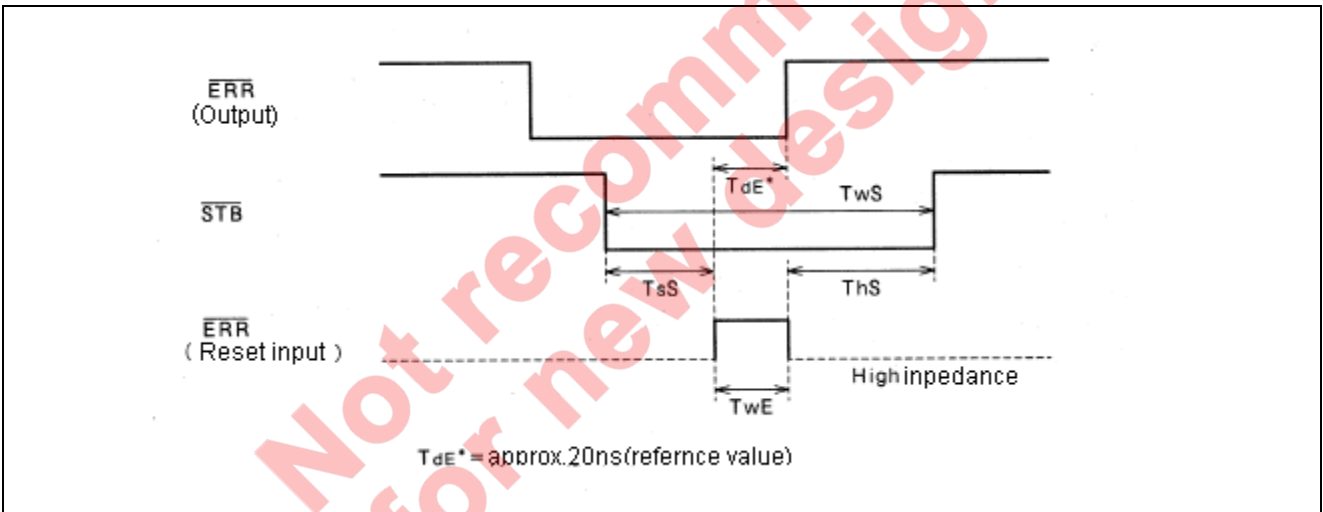

Application Circuit Example (One implementation example, which should be studied carefully)

Example Of Transmission Channel Connection

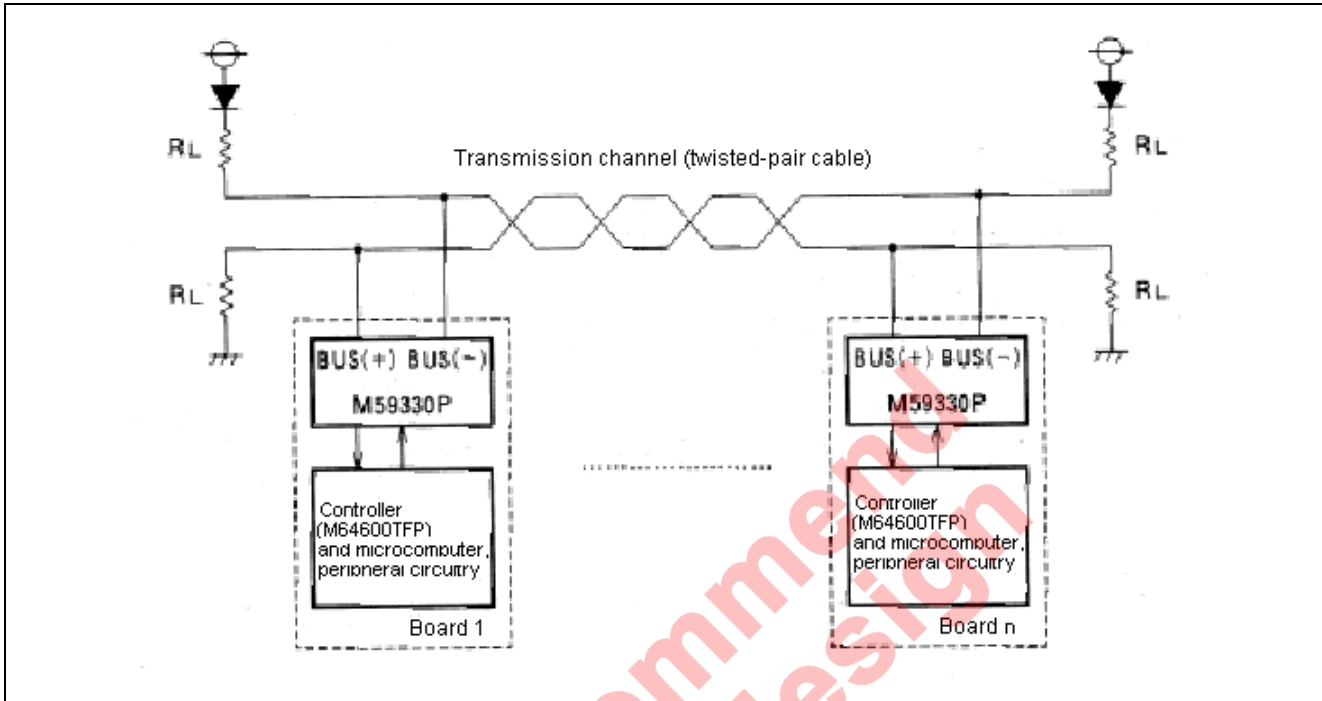

Peripheral Circuit Example

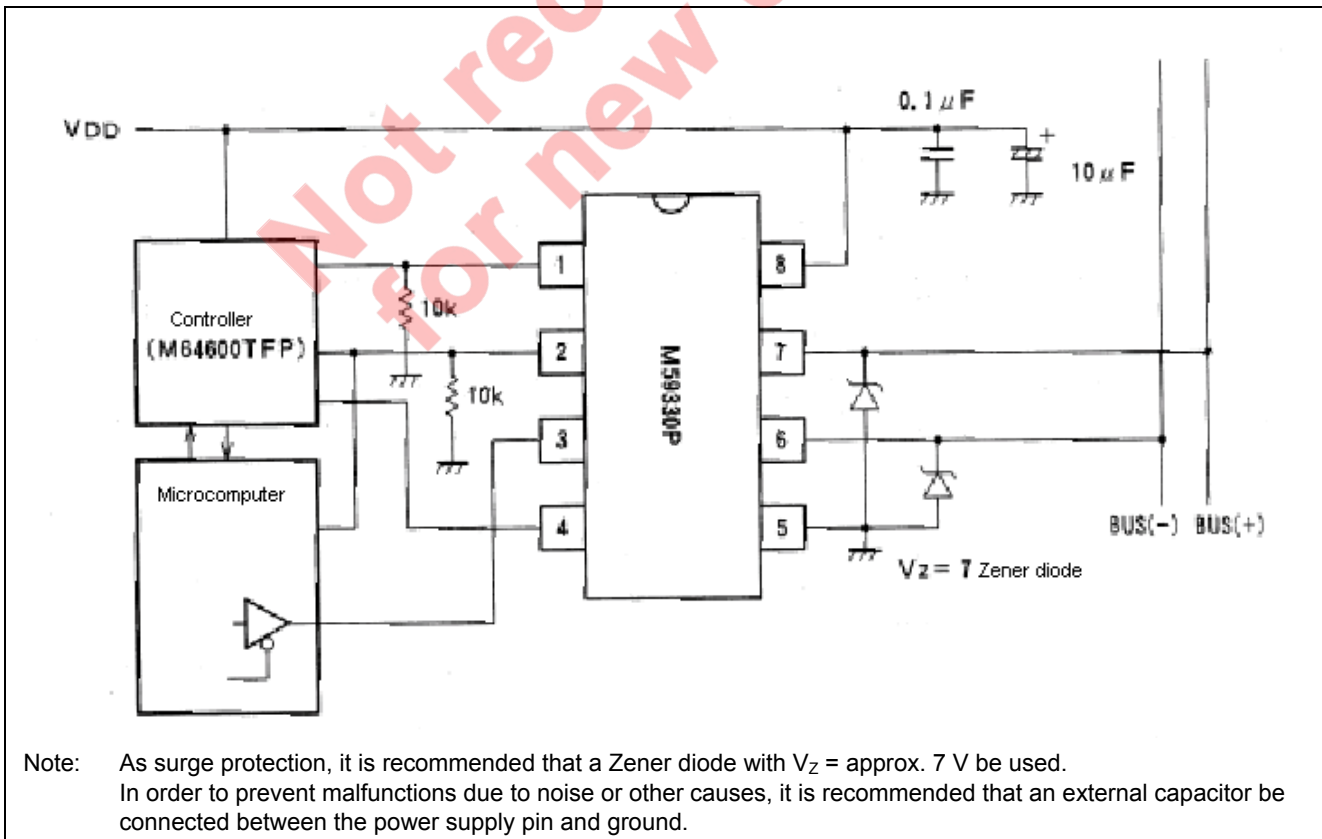

Note: As surge protection, it is recommended that a Zener diode with $V_z =$ approx. 7 V be used. In order to prevent malfunctions due to noise or other causes, it is recommended that an external capacitor be connected between the power supply pin and ground.

Package Dimensions

8P4 **(MMP)** **Plastic 8pin 300mil DIP**

EIAJ Package Code DIP8-P-300-2.54	JEDEC Code -	Weight(g) 0.5	Lead Material Cu Alloy
--------------------------------------	-----------------	------------------	---------------------------

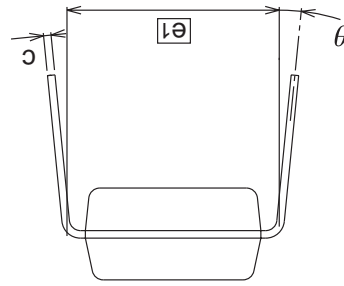
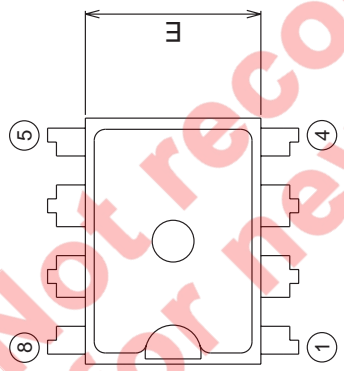
Symbol	Dimension in Millimeters		
	Min	Nom	Max
A	-	-	4.5
A1	0.51	-	-
A2	-	3.3	-
b	0.4	0.5	0.59
b1	1.4	1.5	1.8
b2	0.9	1.0	1.3
c	0.23	0.25	0.35
D	8.7	8.9	9.1
E	6.15	6.3	6.45
e	-	2.45	-
e1	-	7.62	-
L	3.0	-	-
θ	0°	-	15°

Not recommend for new design

Renesas Technology Corp. Sales Strategic Planning Div. Nippon Bldg., 2-6-2, Ohte-machi, Chiyoda-ku, Tokyo 100-0004, Japan

Keep safety first in your circuit designs!

1. Renesas Technology Corp. puts the maximum effort into making semiconductor products better and more reliable, but there is always the possibility that trouble may occur with them. Trouble with semiconductors may lead to personal injury, fire or property damage.
Remember to give due consideration to safety when making your circuit designs, with appropriate measures such as (i) placement of substitutive, auxiliary circuits, (ii) use of nonflammable material or (iii) prevention against any malfunction or mishap.

Notes regarding these materials

1. These materials are intended as a reference to assist our customers in the selection of the Renesas Technology Corp. product best suited to the customer's application; they do not convey any license under any intellectual property rights, or any other rights, belonging to Renesas Technology Corp. or a third party.
2. Renesas Technology Corp. assumes no responsibility for any damage, or infringement of any third-party's rights, originating in the use of any product data, diagrams, charts, programs, algorithms, or circuit application examples contained in these materials.
3. All information contained in these materials, including product data, diagrams, charts, programs and algorithms represents information on products at the time of publication of these materials, and are subject to change by Renesas Technology Corp. without notice due to product improvements or other reasons. It is therefore recommended that customers contact Renesas Technology Corp. or an authorized Renesas Technology Corp. product distributor for the latest product information before purchasing a product listed herein.
The information described here may contain technical inaccuracies or typographical errors.
Renesas Technology Corp. assumes no responsibility for any damage, liability, or other loss rising from these inaccuracies or errors.
Please also pay attention to information published by Renesas Technology Corp. by various means, including the Renesas Technology Corp. Semiconductor home page (<http://www.renesas.com>).
4. When using any or all of the information contained in these materials, including product data, diagrams, charts, programs, and algorithms, please be sure to evaluate all information as a total system before making a final decision on the applicability of the information and products. Renesas Technology Corp. assumes no responsibility for any damage, liability or other loss resulting from the information contained herein.
5. Renesas Technology Corp. semiconductors are not designed or manufactured for use in a device or system that is used under circumstances in which human life is potentially at stake. Please contact Renesas Technology Corp. or an authorized Renesas Technology Corp. product distributor when considering the use of a product contained herein for any specific purposes, such as apparatus or systems for transportation, vehicular, medical, aerospace, nuclear, or undersea repeater use.
6. The prior written approval of Renesas Technology Corp. is necessary to reprint or reproduce in whole or in part these materials.
7. If these products or technologies are subject to the Japanese export control restrictions, they must be exported under a license from the Japanese government and cannot be imported into a country other than the approved destination.
Any diversion or reexport contrary to the export control laws and regulations of Japan and/or the country of destination is prohibited.
8. Please contact Renesas Technology Corp. for further details on these materials or the products contained therein.



RENESAS SALES OFFICES

<http://www.renesas.com>

Renesas Technology America, Inc.
450 Holger Way, San Jose, CA 95134-1368, U.S.A
Tel: <1> (408) 382-7500 Fax: <1> (408) 382-7501

Renesas Technology Europe Limited.
Dukes Meadow, Millboard Road, Bourne End, Buckinghamshire, SL8 5FH, United Kingdom
Tel: <44> (1628) 585 100, Fax: <44> (1628) 585 900

Renesas Technology Europe GmbH
Dornacher Str. 3, D-85622 Feldkirchen, Germany
Tel: <49> (89) 380 70 0, Fax: <49> (89) 929 30 11

Renesas Technology Hong Kong Ltd.
7/F., North Tower, World Finance Centre, Harbour City, Canton Road, Hong Kong
Tel: <852> 2265-6688, Fax: <852> 2375-6836

Renesas Technology Taiwan Co., Ltd.
FL 10, #99, Fu-Hsing N. Rd., Taipei, Taiwan
Tel: <886> (2) 2715-2888, Fax: <886> (2) 2713-2999

Renesas Technology (Shanghai) Co., Ltd.
26/F., Ruijin Building, No.205 Maoming Road (S), Shanghai 200020, China
Tel: <86> (21) 6472-1001, Fax: <86> (21) 6415-2952

Renesas Technology Singapore Pte. Ltd.
1, Harbour Front Avenue, #06-10, Keppel Bay Tower, Singapore 098632
Tel: <65> 6213-0200, Fax: <65> 6278-8001