

## 8 M-BIT SYNCHRONOUS GRAM

## 128K-WORD BY 32-BIT BY 2-BANK

### Description

The  $\mu$ PD481850 is a synchronous graphics memory (SGRAM) organized as 131,072 words  $\times$  32 bits  $\times$  2 banks random access port.

This device can operate up to 100 MHz by using synchronous interface. Also, it has 8-column Block Write function to improve capability in graphics system.

This product is packaged in 100-pin plastic QFP (14  $\times$  20 mm).

### Features

- 131,072 words  $\times$  32 bits  $\times$  2 banks memory
- Synchronous interface (Fully synchronous DRAM with all input signals are latched at rising edge of clock)
  - : Pulsed interface
  - : Automatic precharge and controlled precharge commands
  - : Ping-pong operation between the two internal memory banks
  - : Up to 100 MHz operation frequency
- Possible to assert random column address in every cycle
- Dual internal banks controlled by A9 (Bank Address: BA)
- Byte control using DQM0 to DQM3 signals both in read and write cycle
- 8-column Block Write (BW) function
- Persistent write per bit (WPB) function
- Wrap sequence : Sequential / Interleave
- Programmable burst length (1, 2, 4, 8 and full page)
- Programmable /CAS latency (2 and 3)
- Power Down operation and Clock Suspend operation
- Auto refresh (CBR refresh) or self refresh capability
- Single 3.3 V  $\pm$  0.3 V power supply
- LVTTTL compatible inputs and outputs
- 100-pin Plastic QFP (14  $\times$  20 mm)
- 1,024 refresh cycles/16 ms
- Burst termination by Precharge command
- Burst termination by Burst stop command (in case of full page burst)

### Ordering Information

Part number	Cycle time ns (MIN.)	Clock frequency MHz (MAX.)	Package
$\mu$ PD481850GF-A10-JBT	10	100	100-pin Plastic QFP (14 $\times$ 20 mm)
$\mu$ PD481850GF-A12-JBT	12	83	

The information in this document is subject to change without notice.

**Part Number**

**Synchronous GRAM**

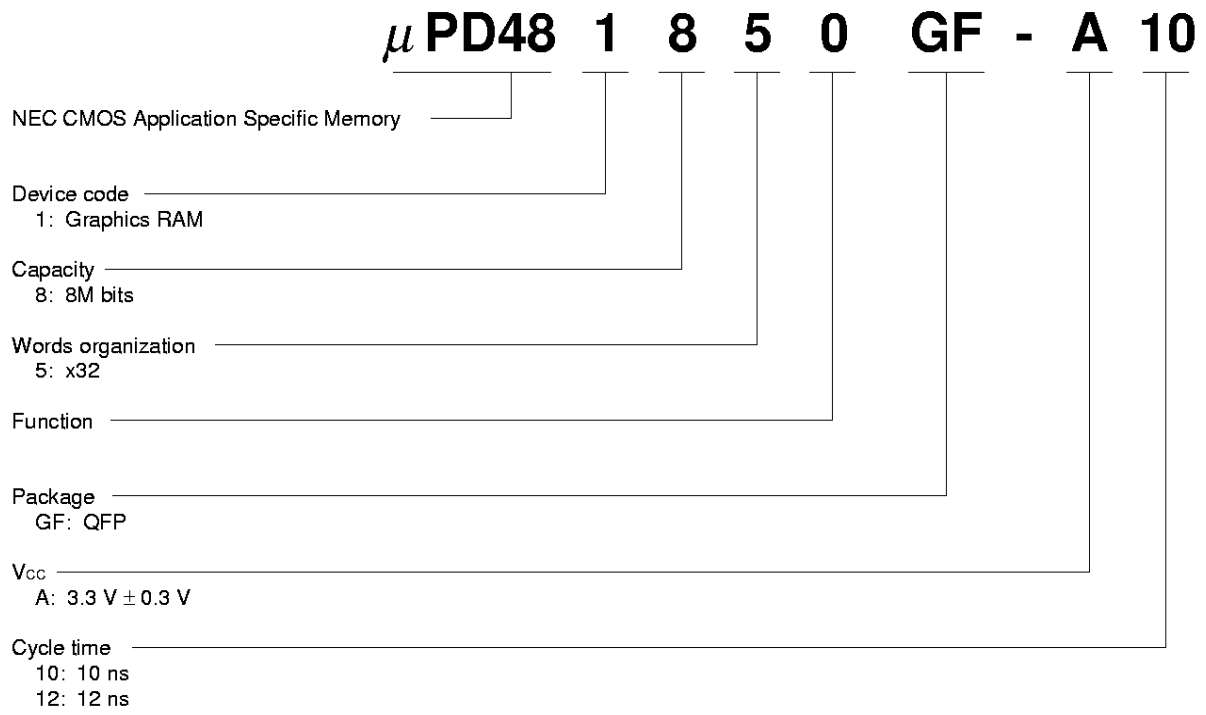

Pin Configuration

100-pin Plastic QFP (14 × 20 mm)

μPD481850GF-Axx-JBT

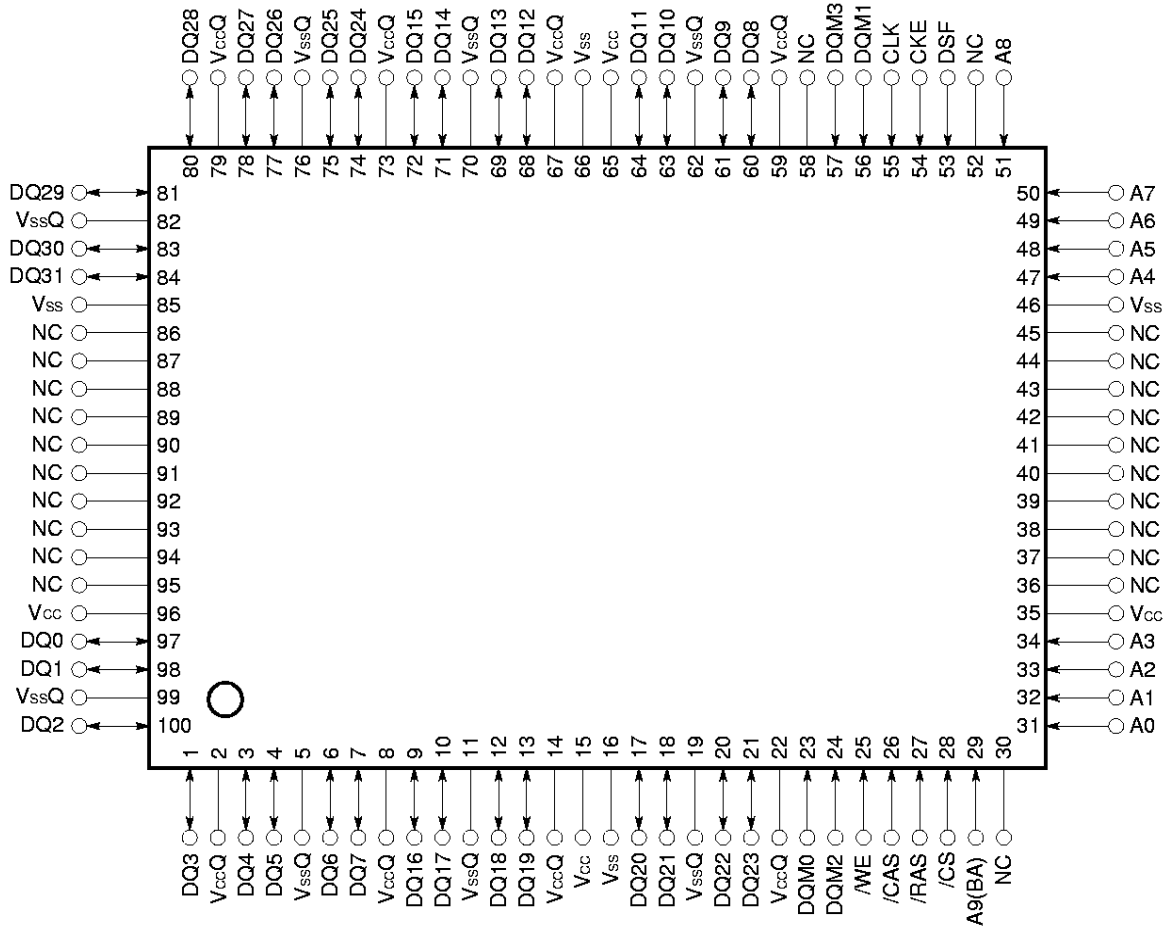

- A0 - A9 : Address inputs
- A0 - A8 : Row address inputs
- A0 - A7 : Column address inputs
- A9 (BA) : Bank address
- DQ0 - DQ31 : Data inputs/outputs
- /CS : Chip select
- /RAS : Row address strobe
- /CAS : Column address strobe
- /WE : Write enable
- DQM0 - DQM3 : DQ mask enable
- DSF : Special function enable
- CKE : Clock enable
- CLK : System clock input
- Vcc : Supply voltage
- Vss : Ground
- VccQ : Supply voltage for DQ
- VssQ : Ground for DQ
- NC : No connection

Block Diagram

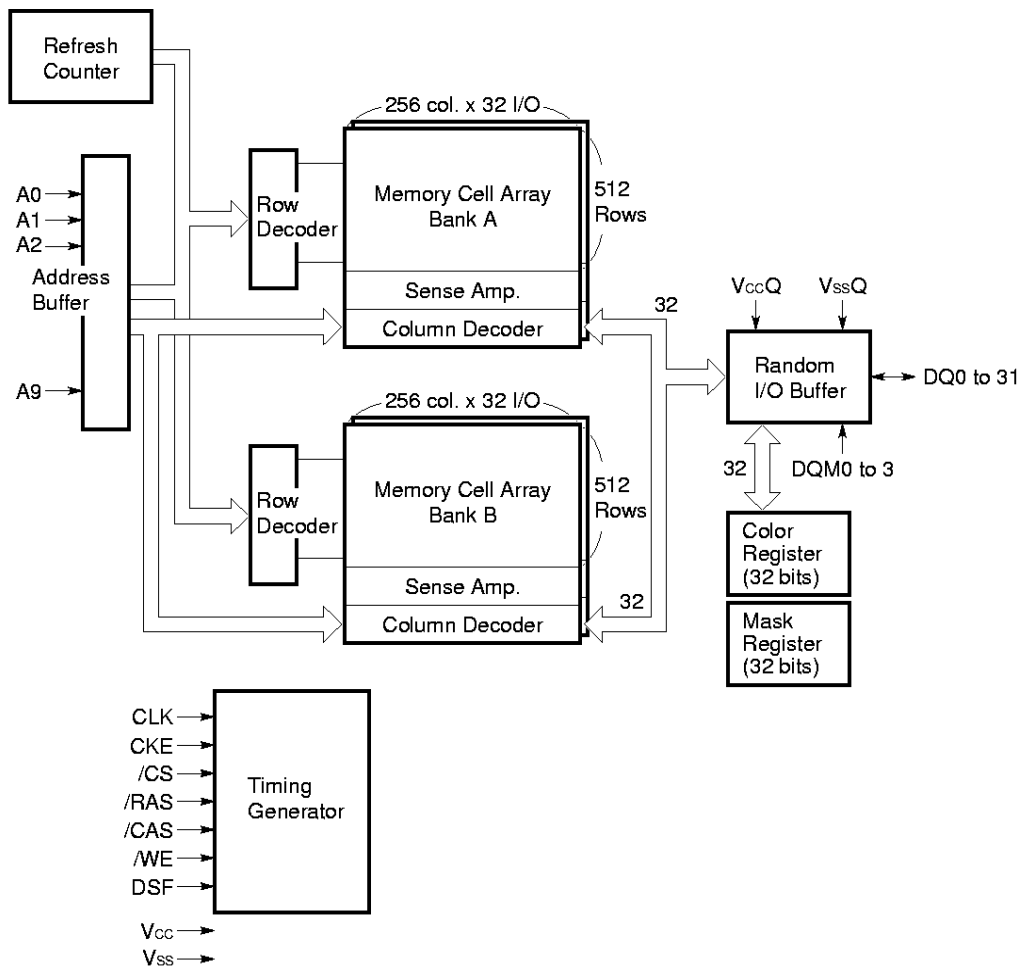

**CONTENTS**

**1. Input/Output Pin Function .....7**

**2. Commands .....8**

**3. Simplified State Diagram .....12**

**4. Truth Table ..... 13**

    4.1 Command Truth Table ..... 13

    4.2 DQM Truth Table ..... 13

    4.3 CKE Truth Table ..... 14

    4.4 Operative Command Table..... 15

    4.5 Command Truth Table for CKE..... 22

    4.6 Command Truth Table for Two Banks Operation ..... 23

**5. Initialization .....24**

**6. Programming the Mode Register .....25**

**7. Mode Register .....26**

    7.1 Burst Length and Sequence ..... 27

**8. Programming the Special Register .....28**

    8.1 Color Register ..... 28

    8.2 Mask Register..... 28

    8.3 Special Register ..... 28

**9. Address Bits of Bank Address and Precharge .....29**

**10. Precharge .....30**

**11. Auto Precharge .....31**

    11.1 Read with Auto Precharge ..... 31

    11.2 Write with Auto Precharge ..... 32

    11.3 Block Write with Auto Precharge..... 33

**12. Write/Block Write with Write Per Bit .....34**

    12.1 Write Per Bit..... 34

**13. Block Write .....34**

    13.1 Block Write ..... 34

    13.2 Column Mask..... 35

    13.3 Block Write Function ..... 36

- 14. Read/Write Command Interval .....37**
  - 14.1 Read to Read Command Interval ..... 37
  - 14.2 Write to Write Command Interval..... 37
  - 14.3 Write to Read Command Interval..... 38
  - 14.4 Block Write to Write or Write/Block Write Command Interval..... 39
  - 14.5 Block Write to Read Command Interval ..... 39
  - 14.6 Read to Write/Block Write Command Interval ..... 40
  
- 15. Burst Termination.....41**
  - 15.1 Burst Stop Command in Full Page ..... 41
  - 15.2 Precharge Termination ..... 42
    - 15.2.1 Precharge Termination in READ Cycle ..... 42
    - 15.2.2 Precharge Termination in WRITE cycle ..... 43
  
- 16. Electrical Specifications (Preliminary) .....44**
  - 16.1 AC Parameters for Read/Write Cycles..... 49
  - 16.2 Relationship between Frequency and Latency ..... 51
  - 16.3 /CS Function ..... 52
  - 16.4 Basic Cycles ..... 53
    - 16.4.1 Initialization ..... 53
    - 16.4.2 Mode Register Set..... 54
    - 16.4.3 Refresh Cycle..... 55
    - 16.4.4 Cycle with Auto Precharge ..... 57
    - 16.4.5 Full Page Mode Cycle ..... 61
    - 16.4.6 Precharge Termination Cycle ..... 65
    - 16.4.7 Clock Suspension ..... 67
    - 16.4.8 Power Down Mode ..... 71
    - 16.4.9 Other Cycles..... 72
  - 16.5 Graphics Cycles ..... 74
  - 16.6 Application Cycles ..... 79
    - 16.6.1 Page Cycles with Same Bank ..... 79
    - 16.6.2 Cycles with Ping-pong Banks..... 83
    - 16.6.3 READ and WRITE Cycles ..... 87
    - 16.6.4 Full Page Random Cycles..... 89
  
- 17. Package Drawing .....91**
  
- 18. Recommended Soldering Conditions .....92**

1. Input/Output Pin Function

Pin name	Input/Output	Function
CLK	Input	CLK is the master clock input. Other inputs signals are referenced to the CLK rising edge.
CKE	Input	CKE determine validity of the next CLK (clock). If CKE is high, the next CLK rising edge is valid; otherwise it is invalid. If the CLK rising edge is invalid, the internal clock is not asserted and the μPD481850 suspends operation. When the μPD481850 is not in burst mode and CKE is negated, the device enters power down mode. During power down mode, CKE must remain low. In Self refresh mode, low level on this pin is also used as part of the input command to specify Self refresh.
/CS	Input	/CS low starts the command input cycle. When /CS is high, commands are ignored but operations continue.
/RAS, /CAS, /WE	Input	/RAS, /CAS and /WE have the same symbols on conventional DRAM but different functions. For details, refer to the command table.
DSF	Input	DSF is part of the inputs of graphics command of the μPD481850. If DSF is inactive (Low level), μPD481850 operates as same as SDRAM.
A0 - A8	Input	Row Address is determined by A0 - A8 at the CLK (clock) rising edge in the activate command cycle. Column Address is determined by A0 - A7 at the CLK rising edge in the read or write command cycle. A8 defines the precharge mode. When A8 is high in the precharge command cycle, both banks are precharged; when A8 is low, only the bank selected by A9 is precharged. When A8 is high in read or write command cycle, the precharge starts automatically after the burst access.
A9		A9 is the bank address signal (BA). In command cycle, A9 low selects bank A and A9 high selects bank B.
DQM0 - DQM3	Input	DQM controls I/O buffers. DQM0 corresponds to the lowest byte (DQ0 to DQ7), DQM1 corresponds to DQ8 to DQ15, DQM2 corresponds to DQ16 to DQ23. DQM3 corresponds to DQ24 to DQ31. In read mode, DQM controls the output buffers like a conventional /OE pin. DQM high and DQM low turn the output buffers off and on, respectively. The DQM latency for the read is two clocks. In write mode, DQM controls the word mask. Input data is written to the memory cell if DQM is low but not if DQM is high. The DQM latency for the write is zero.
DQ0 - DQ31	Input/Output	DQ pins have the same function as I/O pins on a conventional DRAM. These are normally 32-bit data bus and are used for inputting and outputting data. • Function as the mask data input pins in the special register set command. Write operations can be performed after Active command with WPB (old mask data). • Functions as the column selection data input pin in the block write cycle.
V <sub>cc</sub> V <sub>ss</sub> V <sub>ccQ</sub> V <sub>ssQ</sub>	(Power supply)	V <sub>cc</sub> and V <sub>ss</sub> are power supply pins for internal circuits. V <sub>ccQ</sub> and V <sub>ssQ</sub> are power supply pins for the output buffers.

2. Commands

Mode register set command

(/CS, /RAS, /CAS, /WE, DSF = Low)

The μPD481850 has a mode register that defines how the device operates. In this command, A0 through A9 are the data input pins. After power on, the mode register set command must be executed to initialize the device.

The mode register can be set only when both banks are in idle state.

During 2 CLK (trsc) following this command, the μPD481850 cannot accept any other commands.

Refer to 6. Programming the Mode Register.

Fig.1 Mode register set command

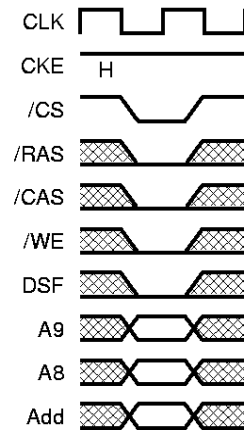

Bank activate command

(/CS, /RAS, /DSF = Low, /CAS, /WE = High)

The μPD481850 has two banks, each with 512 rows.

This command activates the bank selected by A9 (BA) and a row address selected by A0 through A8.

This command corresponds to a conventional DRAM's /RAS falling.

Fig.2 Row address strobe and bank activate command

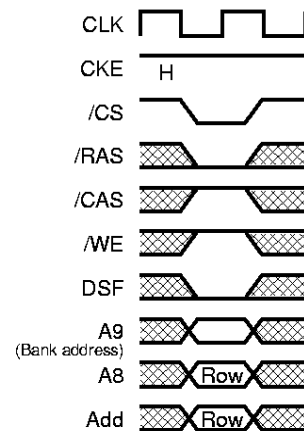

Bank activate command with WPB enable

(/CS, /RAS = Low, /CAS, /WE, /DSF = High)

This command is same as Bank activate command. After this command, write per bit function is available. Mask register's data is used as write mask data.

Refer to 12. Write/Block Write with Write Per Bit.

Fig.3 Row address strobe and bank activate command with WPB enable

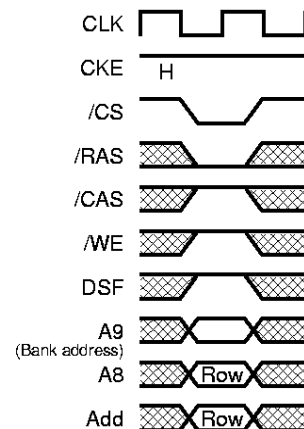



**Precharge command**

(/CS, /RAS, /WE, DSF = Low, /CAS = High)

This command begins precharge operation of the bank selected by A9 (BA) and A8. When A8 is High, both banks are precharged, regardless of A9. When A8 is Low, only the bank selected by A9 is precharged. A9 low selects bank A and A9 high selects bank B.

After this command, the μPD481850 can't accept the activate command to the precharging bank during tRP (precharge to activate command period). This command can terminate the current burst operation (2, 4, 8, full page burst length).

This command corresponds to a conventional DRAM's RAS rising. Refer to 10. Precharge and 11. Auto Precharge.

**Fig.4 Precharge command**

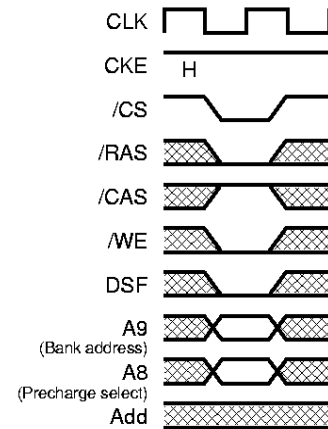

**Write command**

(/CS, /CAS, /WE, DSF = Low, /RAS = High)

If the mode register is in the burst write mode, this command sets the burst start address given by the column address to begin the burst write operation. The first write data must be input with this write operation. The first write data in burst mode can input with this command with subsequent data on following clocks.

**Fig.5 Column address and write command**

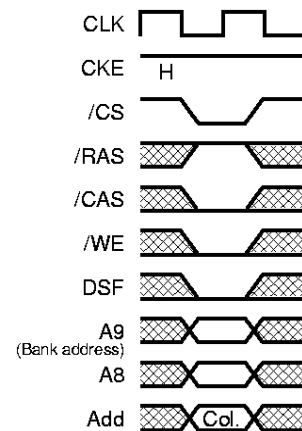

**Read command**

(/CS, /CAS, DSF = Low, /RAS, /WE = High)

This command sets the burst start address given by the column address. Read data is available after /CAS latency requirements have been met.

**Fig.6 Column address and read command**

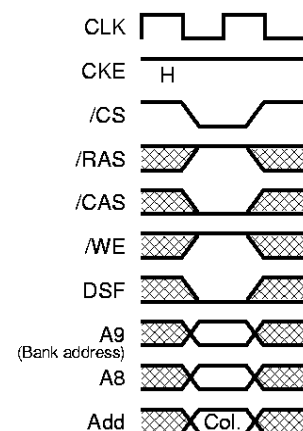

**CBR (auto) refresh command**

(/CS, /RAS, /CAS, DSF = Low, /WE, CKE = High)

This command is a request to begin the CBR refresh operation. The refresh address is generated internally.

Before executing CBR refresh, both banks must be precharged.

After this cycle, both banks will be in the idle (precharged) state and ready for a bank activate command.

During t<sub>RC</sub> period (from refresh command to refresh or activate command), the μPD481850 cannot accept any other command.

**Fig.7 CBR (auto) refresh command**

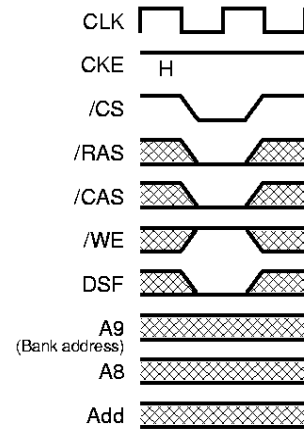

**Self refresh entry command**

(/CS, /RAS, /CAS, DSF, CKE = Low, /WE = High)

After the command execution, self refresh operation continues while CKE remains low. When CKE goes high, the μPD481850 exits the self refresh mode.

During self refresh mode, refresh interval and refresh operation are performed internally, so there is no need for external control.

Before executing self refresh, both banks must be precharged.

**Fig.8 Self refresh entry command**

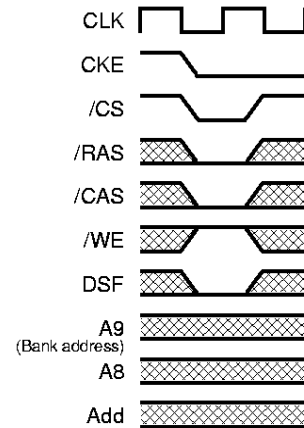

**Burst stop command in full page**

(/CS, /WE, DSF = Low, /RAS, /CAS = High)

This command can stop the current full page burst (BL = 256) operation. If BL is set to 2, 4, 8, to execute this command is Nop.

Refer to 14. Read/Write Command Interval and 15. Burst Termination.

**Fig.9 Burst stop command in Full Page Mode**

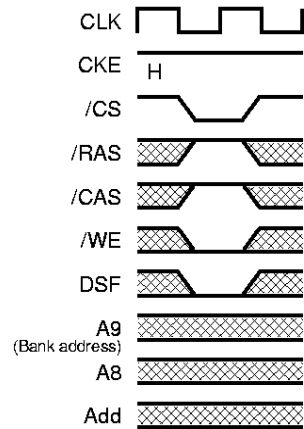

**No operation**

(/CS, DSF = Low, /RAS, /CAS, /WE = High)

This command is not a execution command. No operations begin or terminate by this command.

**Fig.10 No operation**

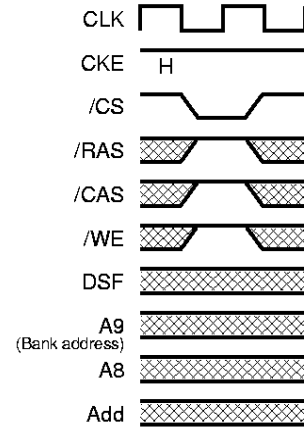

**Special register set command**

(/CS, /RAS, /CAS, /WE = Low, DSF = High)

The μPD481850 has two special registers for graphics commands. One is color register and the other is mask register. In this command, A0 through A9 are the data input pins for the register select (color or mask register). DQ0 through DQ31 are the data input pins for the Color data or the WPB data.

During 2 CLK ( $t_{RSC}$ ) following this command, the μPD481850 can not accept any other commands.

Refer to **8. Programming the Special Register**.

**Fig.11 Special register set command**

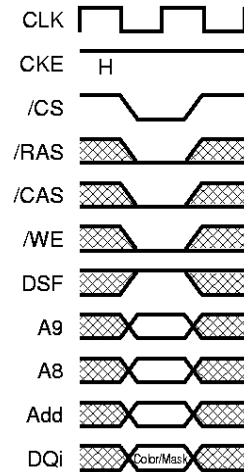

**Masked block write command**

(/CS, /CAS, /WE = Low, /RAS, DSF = High)

This command activates 8-column block write function. In this command, the burst length = 1. Write data comes from color register, column address mask data is input from DQi in this command.

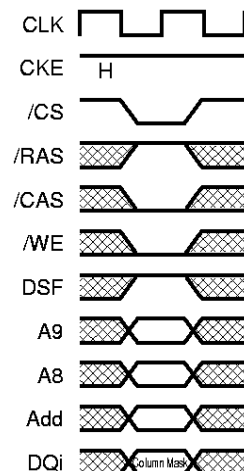

Refer to **13. Block Write**.

**Fig.12 Masked block write command**

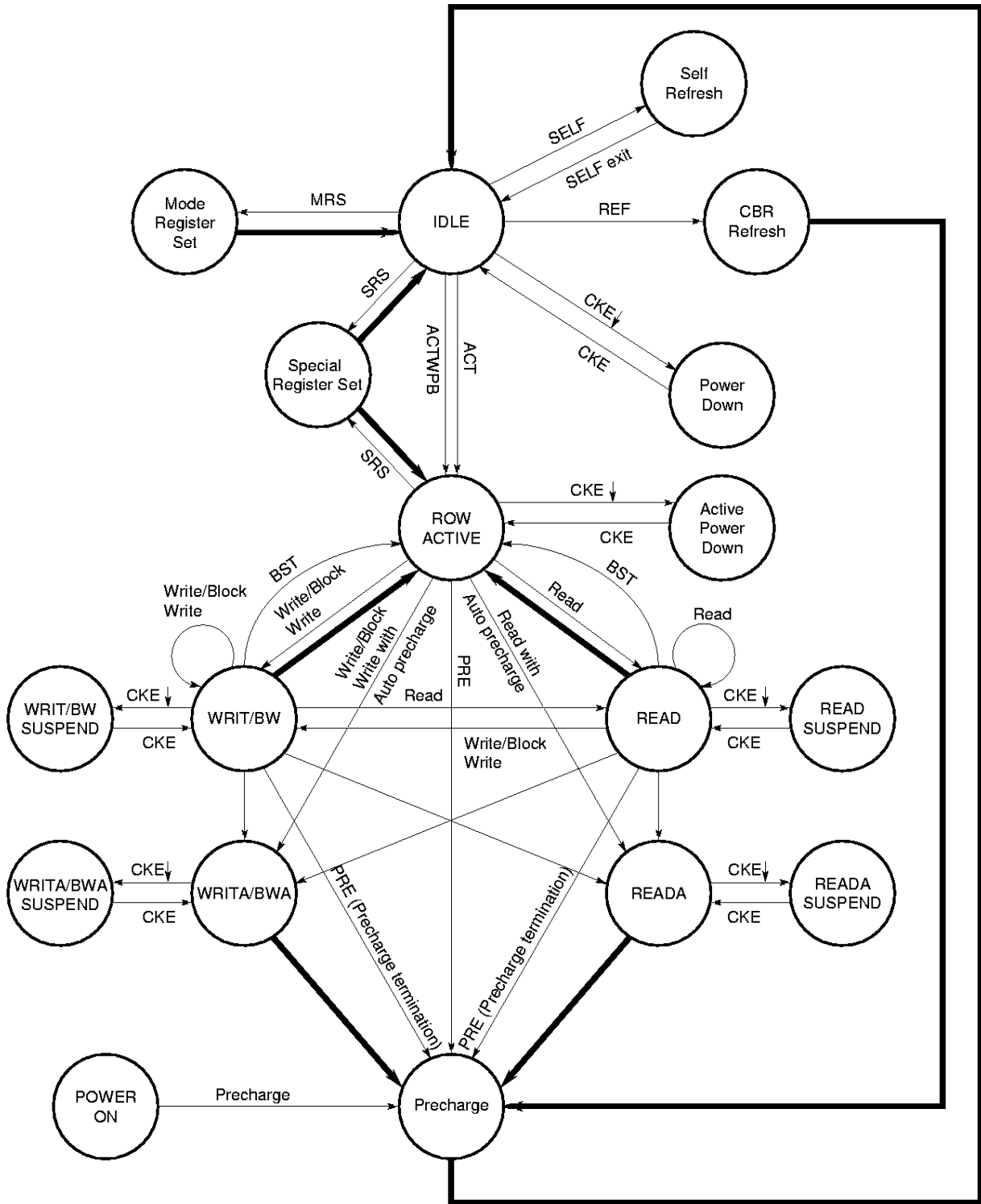

3. Simplified State Diagram



 Automatic sequence  
 Manual input

4. Truth Table

4.1 Command Truth Table

Function	Symbol	CKE		/CS	/RAS	/CAS	/WE	DSF	Address		
		n - 1	n						A9	A8	A7-A0
Device deselect	DESL	H	x	H	x	x	x	x	x	x	x
No operation	NOP	H	x	L	H	H	H	L	x	x	x
Burst stop in full page	BST	H	x	L	H	H	L	L	x	x	x
Read	READ	H	x	L	H	L	H	L	BA	L	CA
Read with auto precharge	READA	H	x	L	H	L	H	L	BA	H	CA
Write	WRIT	H	x	L	H	L	L	L	BA	L	CA
Write with auto precharge	WRITA	H	x	L	H	L	L	L	BA	H	CA
Masked block write	BW	H	x	L	H	L	L	H	BA	L	CA
Masked block write with auto precharge	BWA	H	x	L	H	L	L	H	BA	H	CA
Bank activate	ACT	H	x	L	L	H	H	L	BA	RA	
Bank activate with WPB enable	ACTWPB	H	x	L	L	H	H	H	BA	RA	
Precharge select bank	PRE	H	x	L	L	H	L	L	BA	L	x
Precharge all banks	PALL	H	x	L	L	H	L	L	x	H	x
Mode register set	MRS	H	x	L	L	L	L	L	OP.CODE		
Special register set	SRS	H	x	L	L	L	L	H	OP.CODE		

**Remark** H = High level, L = Low level, x = High or Low level (Don' t care), BA = Bank address(A9), RA = Row address, CA = Column address

4.2 DQM Truth Table

Function	Symbol	CKE		DQMi
		n - 1	n	
Data write/output enable	ENBi	H	x	L
Data mask/output enable	MASKi	H	x	H

**Remark** H = High level, L = Low level, x = High or Low level (Don' t care), i = 0, 1, 2, 3

4.3 CKE Truth Table

Current state	Function	Symbol	CKE		/CS	/RAS	/CAS	/WE	DSF	Address
			n - 1	n						
Activating	Clock suspend mode entry		H	L	x	x	x	x	x	x
Any	Clock suspend		L	L	x	x	x	x	x	x
Clock suspend	Clock suspend mode exit		L	H	x	x	x	x	x	x
Idle	CBR refresh command	REF	H	H	L	L	L	H	L	x
Idle	Self refresh entry	SELF	H	L	L	L	L	H	L	x
Self refresh	Self refresh exit		L	H	L	H	H	H	x	x
			L	H	H	x	x	x	x	x
Idle	Power down entry		H	L	x	x	x	x	x	x
Power down	Power down exit		L	H	x	x	x	x	x	x

**Remark** H = High level, L = Low level, x = High or Low level (Don't care)

4.4 Operative Command Table <sup>Note 1</sup>

(1/7)

Current state	/CS	/RAS	/CAS	/WE	DSF	Address	Command	Action	Notes
Idle	H	x	x	x	x	x	DESL	Nop or Power down	2
	L	H	H	H	x	x	NOP	Nop or Power down	2
	L	H	H	L	H	x	Undefined	ILLEGAL	
	L	H	H	L	L	x	BST	ILLEGAL	3
	L	H	L	H	H	x	Undefined	ILLEGAL	
	L	H	L	H	L	BA, CA, A8	READ/READA	ILLEGAL	3
	L	H	L	L	H	BA, CA, A8	BW/BWA	ILLEGAL	3
	L	H	L	L	L	BA, CA, A8	WRIT/WRITA	ILLEGAL	3
	L	L	H	H	H	BA, RA	ACTWPB	Bank active with WPB: Latch RA	
	L	L	H	H	L	BA, RA	ACT	Bank active: Latch RA	
	L	L	H	L	H	x	Undefined	ILLEGAL	
	L	L	H	L	L	BA, A8	PRE/PALL	Nop	11
	L	L	L	H	H	x	Undefined	ILLEGAL	
	L	L	L	H	L	x	REF/SELF	CBR refresh/Self refresh	4, 12
	L	L	L	L	H	Op-Code	SRS	Special register access	
	L	L	L	L	L	Op-Code	MRS	Mode register access	12
Bank active	H	x	x	x	x	x	DESL	Nop	
	L	H	H	H	x	x	NOP	Nop	
	L	H	H	L	H	x	Undefined	ILLEGAL	
	L	H	H	L	L	x	BST	ILLEGAL	3
	L	H	L	H	H	x	Undefined	ILLEGAL	
	L	H	L	H	L	BA, CA, A8	READ/READA	Begin read; Latch CA: Determine AP	5
	L	H	L	L	H	BA, CA, A8	BW/BWA	Begin block write; Latch CA: Determine AP	5
	L	H	L	L	L	BA, CA, A8	WRIT/WRITA	Begin write; Latch CA: Determine AP	5
	L	L	H	H	H	BA, RA	ACTWPB	ILLEGAL	3
	L	L	H	H	L	BA, RA	ACT	ILLEGAL	3
	L	L	H	L	H	x	Undefined	ILLEGAL	
	L	L	H	L	L	BA, A8	PRE/PALL	Precharge	6
	L	L	L	H	H	x	Undefined	ILLEGAL	
	L	L	L	H	L	x	REF/SELF	ILLEGAL	
	L	L	L	L	H	Op-Code	SRS	Special register access	
	L	L	L	L	L	Op-Code	MRS	ILLEGAL	

(2/7)

Current state	/CS	/RAS	/CAS	/WE	DSF	Address	Command	Action	Notes
Read	H	x	x	x	x	x	DESL	Continue burst to end → Bank active	
	L	H	H	H	x	x	NOP	Continue burst to end → Bank active	
	L	H	H	L	H	x	Undefined	ILLEGAL	
	L	H	H	L	L	x	BST	1, 2, 4, 8 burst length; Nop(Continue burst to end → Bank active) Full page burst; Burst stop → Bank active	
	L	H	L	H	H	x	Undefined	ILLEGAL	
	L	H	L	H	L	BA, CA, A8	READ/READA	Term burst, new read: Determine AP	7
	L	H	L	L	H	BA, CA, A8	BW/BWA	Term burst, Start block write: Determine AP	7, 8
	L	H	L	L	L	BA, CA, A8	WRIT/WRITA	Term burst, Start write: Determine AP	7, 8
	L	L	H	H	H	BA, RA	ACTWPB	ILLEGAL	3
	L	L	H	H	L	BA, RA	ACT	ILLEGAL	3
	L	L	H	L	H	x	Undefined	ILLEGAL	
	L	L	H	L	L	BA, A8	PRE/PALL	Term burst, precharge timing for reads	
	L	L	L	H	H	x	Undefined	ILLEGAL	
	L	L	L	H	L	x	REF/SELF	ILLEGAL	
	L	L	L	L	H	Op-Code	SRS	ILLEGAL	
L	L	L	L	L	Op-Code	MRS	ILLEGAL		
Write/Block write	H	x	x	x	x	x	DESL	Continue burst to end → Write recovering	
	L	H	H	H	x	x	NOP	Continue burst to end → Write recovering	
	L	H	H	L	H	x	Undefined	ILLEGAL	
	L	H	H	L	L	x	BST	1, 2, 4, 8 burst length; Nop(Continue burst to end → Bank active) Full page burst; Burst stop → Bank active	
	L	H	L	H	H	x	Undefined	ILLEGAL	7, 8
	L	H	L	H	L	BA, CA, A8	READ/READA	Term burst, start read: Determine AP	7, 8
	L	H	L	L	H	BA, CA, A8	BW/BWA	Term burst, new block write: Determine AP	7
	L	H	L	L	L	BA, CA, A8	WRIT/WRITA	Term burst, new write: Determine AP	7
	L	L	H	H	H	BA, RA	ACTWPB	ILLEGAL	3
	L	L	H	H	L	BA, RA	ACT	ILLEGAL	3
	L	L	H	L	H	x	Undefined	ILLEGAL	
	L	L	H	L	L	BA, A8	PRE/PALL	Term burst, precharge timing for writes	3, 9
	L	L	L	H	H	x	Undefined	ILLEGAL	
	L	L	L	H	L	x	REF/SELF	ILLEGAL	
	L	L	L	L	H	Op-Code	SRS	ILLEGAL	
L	L	L	L	L	Op-Code	MRS	ILLEGAL		



(3/7)

Current state	/CS	/RAS	/CAS	/WE	DSF	Address	Command	Action	Notes
Read with auto precharge	H	x	x	x	x	x	DESL	Continue burst to end → precharging	
	L	H	H	H	x	x	NOP	Continue burst to end → precharging	
	L	H	H	L	H	x	Undefined	ILLEGAL	
	L	H	H	L	L	x	BST	ILLEGAL	
	L	H	L	H	H	x	Undefined	ILLEGAL	
	L	H	L	H	L	BA, CA, A8	READ/READA	ILLEGAL	
	L	H	L	L	H	BA, CA, A8	BW/BWA	ILLEGAL	
	L	H	L	L	L	BA, CA, A8	WRIT/WRITA	ILLEGAL	
	L	L	H	H	H	BA, RA	ACTWPB	ILLEGAL	3
	L	L	H	H	L	BA, RA	ACT	ILLEGAL	3
	L	L	H	L	H	x	Undefined	ILLEGAL	
	L	L	H	L	L	BA, A8	PRE/PALL	ILLEGAL	3
	L	L	L	H	H	x	Undefined	ILLEGAL	
	L	L	L	H	L	x	REF/SELF	ILLEGAL	
	L	L	L	L	H	Op-Code	SRS	ILLEGAL	
L	L	L	L	L	Op-Code	MRS	ILLEGAL		
Write/Block write with auto precharge	H	x	x	x	x	x	DESL	Continue burst to end → Write recovering with auto precharge	
	L	H	H	H	x	x	NOP	Continue burst to end → Write recovering with auto precharge	
	L	H	H	L	H	x	Undefined	ILLEGAL	
	L	H	H	L	L	x	BST	ILLEGAL	
	L	H	L	H	H	x	Undefined	ILLEGAL	
	L	H	L	H	L	BA, CA, A8	READ/READA	ILLEGAL	
	L	H	L	L	H	BA, CA, A8	BW/BWA	ILLEGAL	
	L	H	L	L	L	BA, CA, A8	WRIT/WRITA	ILLEGAL	
	L	L	H	H	H	BA, RA	ACTWPB	ILLEGAL	3
	L	L	H	H	L	BA, RA	ACT	ILLEGAL	3
	L	L	H	L	H	x	Undefined	ILLEGAL	
	L	L	H	L	L	BA, A8	PRE/PALL	ILLEGAL	3
	L	L	L	H	H	x	Undefined	ILLEGAL	
	L	L	L	H	L	x	REF/SELF	ILLEGAL	
	L	L	L	L	H	Op-Code	SRS	ILLEGAL	
L	L	L	L	L	Op-Code	MRS	ILLEGAL		

(4/7)

Current state	/CS	/RAS	/CAS	/WE	DSF	Address	Command	Action	Notes
Precharging	H	x	x	x	x	x	DESL	Nop → Enter idle after trp	
	L	H	H	H	x	x	NOP	Nop → Enter idle after trp	
	L	H	H	L	H	x	Undefined	ILLEGAL	
	L	H	H	L	L	x	BST	ILLEGAL	3
	L	H	L	H	H	x	Undefined	ILLEGAL	
	L	H	L	H	L	BA, CA, A8	READ/READA	ILLEGAL	3
	L	H	L	L	H	BA, CA, A8	BW/BWA	ILLEGAL	3
	L	H	L	L	L	BA, CA, A8	WRIT/WRITA	ILLEGAL	3
	L	L	H	H	H	BA, RA	ACTWPB	ILLEGAL	3
	L	L	H	H	L	BA, RA	ACT	ILLEGAL	3
	L	L	H	L	H	x	Undefined	ILLEGAL	
	L	L	H	L	L	BA, A8	PRE/PALL	Nop → Enter idle after trp	11
	L	L	L	H	H	x	Undefined	ILLEGAL	
	L	L	L	H	L	x	REF/SELF	ILLEGAL	
	L	L	L	L	H	Op-Code	SRS	Special register access	
L	L	L	L	L	Op-Code	MRS	ILLEGAL		
Bank activating (trcd)	H	x	x	x	x	x	DESL	Nop → Enter bank active after trcd	
	L	H	H	H	x	x	NOP	Nop → Enter bank active after trcd	
	L	H	H	L	H	x	Undefined	ILLEGAL	
	L	H	H	L	L	x	BST	ILLEGAL	3
	L	H	L	H	H	x	Undefined	ILLEGAL	
	L	H	L	H	L	BA, CA, A8	READ/READA	ILLEGAL	3
	L	H	L	L	H	BA, CA, A8	BW/BWA	ILLEGAL	3
	L	H	L	L	L	BA, CA, A8	WRIT/WRITA	ILLEGAL	3
	L	L	H	H	H	BA, RA	ACTWPB	ILLEGAL	3, 10
	L	L	H	H	L	BA, RA	ACT	ILLEGAL	3, 10
	L	L	H	L	H	x	Undefined	ILLEGAL	
	L	L	H	L	L	BA, A8	PRE/PALL	ILLEGAL	3
	L	L	L	H	H	x	Undefined	ILLEGAL	
	L	L	L	H	L	x	REF/SELF	ILLEGAL	
	L	L	L	L	H	Op-Code	SRS	Special register access	
L	L	L	L	L	Op-Code	MRS	ILLEGAL		

(5/7)

Current state	/CS	/RAS	/CAS	/WE	DSF	Address	Command	Action	Notes
Write recovering (tdPL)	H	x	x	x	x	x	DESL	Nop → Enter bank active after tdPL	
	L	H	H	H	x	x	NOP	Nop → Enter bank active after tdPL	
	L	H	H	L	H	x	Undefined	ILLEGAL	
	L	H	H	L	L	x	BST	ILLEGAL	3
	L	H	L	H	H	x	Undefined	ILLEGAL	
	L	H	L	H	L	BA, CA, A8	READ/READA	Begin read; Latch CA: Determine AP	8
	L	H	L	L	H	BA, CA, A8	BW/BWA	Begin block write; Latch CA: Determine AP	
	L	H	L	L	L	BA, CA, A8	WRIT/WRITA	Begin write; Latch CA: Determine AP	
	L	L	H	H	H	BA, RA	ACTWPB	ILLEGAL	3
	L	L	H	H	L	BA, RA	ACT	ILLEGAL	3
	L	L	H	L	H	x	Undefined	ILLEGAL	
	L	L	H	L	L	BA, A8	PRE/PALL	ILLEGAL	3
	L	L	L	H	H	x	Undefined	ILLEGAL	
	L	L	L	H	L	x	REF/SELF	ILLEGAL	
	L	L	L	L	H	Op-Code	SRS	Special register access	
L	L	L	L	L	Op-Code	MRS	ILLEGAL		
Write recovering with auto precharge	H	x	x	x	x	x	DESL	Nop → Enter precharge after tdPL	
	L	H	H	H	x	x	NOP	Nop → Enter precharge after tdPL	
	L	H	H	L	H	x	Undefined	ILLEGAL	
	L	H	H	L	L	x	BST	ILLEGAL	
	L	H	L	H	H	x	Undefined	ILLEGAL	
	L	H	L	H	L	BA, CA, A8	READ/READA	ILLEGAL	3, 8
	L	H	L	L	H	BA, CA, A8	BW/BWA	ILLEGAL	3
	L	H	L	L	L	BA, CA, A8	WRIT/WRITA	ILLEGAL	3
	L	L	H	H	H	BA, RA	ACTWPB	ILLEGAL	3
	L	L	H	H	L	BA, RA	ACT	ILLEGAL	3
	L	L	H	L	H	x	Undefined	ILLEGAL	
	L	L	H	L	L	BA, A8	PRE/PALL	ILLEGAL	3
	L	L	L	H	H	x	Undefined	ILLEGAL	
	L	L	L	H	L	x	REF/SELF	ILLEGAL	
	L	L	L	L	H	Op-Code	SRS	Special register access	
L	L	L	L	L	Op-Code	MRS	ILLEGAL		

(6/7)

Current state	/CS	/RAS	/CAS	/WE	DSF	Address	Command	Action	Notes
Refreshing	H	x	x	x	x	x	DESL	Nop → Enter idle after t <sub>RC</sub>	
	L	H	H	H	x	x	NOP	Nop → Enter idle after t <sub>RC</sub>	
	L	H	H	L	H	x	Undefined	ILLEGAL	
	L	H	H	L	L	x	BST	ILLEGAL	
	L	H	L	H	H	x	Undefined	ILLEGAL	
	L	H	L	H	L	BA, CA, A8	READ/READA	ILLEGAL	
	L	H	L	L	H	BA, CA, A8	BW/BWA	ILLEGAL	
	L	H	L	L	L	BA, CA, A8	WRIT/WRITA	ILLEGAL	
	L	L	H	H	H	BA, RA	ACTWPB	ILLEGAL	
	L	L	H	H	L	BA, RA	ACT	ILLEGAL	
	L	L	H	L	H	x	Undefined	ILLEGAL	
	L	L	H	L	L	BA, A8	PRE/PALL	ILLEGAL	
	L	L	L	H	H	x	Undefined	ILLEGAL	
	L	L	L	H	L	x	REF/SELF	ILLEGAL	
	L	L	L	L	H	Op-Code	SRS	ILLEGAL	
L	L	L	L	L	Op-Code	MRS	ILLEGAL		
Mode register accessing	H	x	x	x	x	x	DESL	Nop → Enter idle after t <sub>RSC</sub>	
	L	H	H	H	x	x	NOP	Nop → Enter idle after t <sub>RSC</sub>	
	L	H	H	L	H	x	Undefined	ILLEGAL	
	L	H	H	L	L	x	BST	ILLEGAL	
	L	H	L	H	H	x	Undefined	ILLEGAL	
	L	H	L	H	L	BA, CA, A8	READ/READA	ILLEGAL	
	L	H	L	L	H	BA, CA, A8	BW/BWA	ILLEGAL	
	L	H	L	L	L	BA, CA, A8	WRIT/WRITA	ILLEGAL	
	L	L	H	H	H	BA, RA	ACTWPB	ILLEGAL	
	L	L	H	H	L	BA, RA	ACT	ILLEGAL	
	L	L	H	L	H	x	Undefined	ILLEGAL	
	L	L	H	L	L	BA, A8	PRE/PALL	ILLEGAL	
	L	L	L	H	H	x	Undefined	ILLEGAL	
	L	L	L	H	L	x	REF/SELF	ILLEGAL	
	L	L	L	L	H	Op-Code	SRS	ILLEGAL	
L	L	L	L	L	Op-Code	MRS	ILLEGAL		

(7/7)

Current state	/CS	/RAS	/CAS	/WE	DSF	Address	Command	Action	Notes
Special mode register accessing	H	x	x	x	x	x	DESL	Nop → Enter previous state after trsc	
	L	H	H	H	x	x	NOP	Nop → Enter previous state after trsc	
	L	H	H	L	H	x	Undefined	ILLEGAL	
	L	H	H	L	L	x	BST	ILLEGAL	
	L	H	L	H	H	x	Undefined	ILLEGAL	
	L	H	L	H	L	BA, CA, A8	READ/READA	ILLEGAL	
	L	H	L	L	H	BA, CA, A8	BW/BWA	ILLEGAL	
	L	H	L	L	L	BA, CA, A8	WRIT/WRITA	ILLEGAL	
	L	L	H	H	H	BA, RA	ACTWPB	ILLEGAL	
	L	L	H	H	L	BA, RA	ACT	ILLEGAL	
	L	L	H	L	H	x	Undefined	ILLEGAL	
	L	L	H	L	L	BA, A8	PRE/PALL	ILLEGAL	
	L	L	L	H	H	x	Undefined	ILLEGAL	
	L	L	L	H	L	x	REF/SELF	ILLEGAL	
	L	L	L	L	H	Op-Code	SRS	ILLEGAL	
L	L	L	L	L	Op-Code	MRS	ILLEGAL		

- Notes**
- All entries assume that CKE was active (High level) during the preceding clock cycle.
  - If both banks are idle, and CKE is inactive (Low level), μPD481850 will enter Power down mode. All input buffers except CKE will be disabled.
  - Illegal to bank in specified states; Function may be legal in the bank indicated by Bank Address (BA), depending on the state of that bank.
  - If both banks are idle, and CKE is inactive (Low level), μPD481850 will enter Self refresh. All input buffers except CKE will be disabled.
  - Illegal if trcd is not satisfied.
  - Illegal if tras is not satisfied.
  - Must satisfy burst interrupt condition.
  - Must satisfy bus contention, bus turn around, and/or write recovery requirements.
  - Must mask preceding data which don't satisfy tdpl.
  - Illegal if trrd is not satisfied.
  - Nop to bank precharging or in idle state. May precharge bank(s) indicated by BA (and A8).
  - Illegal if any bank is not idle.

**Remark** H = High level, L = Low level, x = High or Low level (Don't care), V = Valid Data input, BA = Bank address (A9), A8 = Precharge select, RA = Row address, CA = Column address, Term = Terminate, AP = Auto precharge, NOP = No operation, ILLEGAL = Device operation and/or data-integrity are not guaranteed

4.5 Command Truth Table for CKE

Current state	CKE		/CS	/RAS	/CAS	/WE	DSF	Address	Action	Notes
	n-1	n								
Self refresh (S.R.)	H	x	x	x	x	x	x	x	INVALID, CLK(n-1) would exit S.R.	
	L	H	H	x	x	x	x	x	S.R. Recovery	
	L	H	L	H	H	x	x	x	S.R. Recovery	
	L	H	L	H	L	x	x	x	ILLEGAL	
	L	H	L	L	x	x	x	x	ILLEGAL	
	L	L	x	x	x	x	x	x	Maintain S.R.	
Self refresh recovery	H	H	H	x	x	x	x	x	Idle after tRC	
	H	H	L	H	H	x	x	x	Idle after tRC	
	H	H	L	H	L	x	x	x	ILLEGAL	
	H	H	L	L	x	x	x	x	ILLEGAL	
	H	L	H	x	x	x	x	x	ILLEGAL	
	H	L	L	H	H	x	x	x	ILLEGAL	
	H	L	L	H	L	x	x	x	ILLEGAL	
	H	L	L	L	x	x	x	x	ILLEGAL	
Power down (P.D.)	H	x	x	x	x	x	x	x	INVALID, CLK(n-1) would exit P.D.	
	L	H	x	x	x	x	x	x	EXIT P.D. → Idle	
	L	L	x	x	x	x	x	x	Maintain power down mode	
Both banks idle	H	H	H	x	x	x	x	x	Refer to operations in Operative Command Table	
	H	H	L	H	x	x	x	x	Refer to operations in Operative Command Table	
	H	H	L	L	H	x	x	x	Refer to operations in Operative Command Table	
	H	H	L	L	L	H	L	x	Refresh	
	H	H	L	L	L	L	x	Op-Code	Refer to operations in Operative Command Table	
	H	L	H	x	x	x	x	x	Refer to operations in Operative Command Table	
	H	L	L	H	x	x	x	x	Refer to operations in Operative Command Table	
	H	L	L	L	H	x	x	x	Refer to operations in Operative Command Table	
	H	L	L	L	L	H	L	x	Self refresh	1
	H	L	L	L	L	L	x	Op-Code	Refer to operations in Operative Command Table	
	L	x	x	x	x	x	x	x	Power down	1
Row active	H	x	x	x	x	x	x	x	Refer to operations in Operative Command Table	
	L	x	x	x	x	x	x	x	Power down	2
Any state other than listed above	H	H	x	x	x	x	x	x	Refer to operations in Operative Command Table	
	H	L	x	x	x	x	x	x	Begin clock suspend next cycle	2
	L	H	x	x	x	x	x	x	Exit clock suspend next cycle	
	L	L	x	x	x	x	x	x	Maintain clock suspend	

**Notes** 1. Self refresh can be entered only from the both banks idle state. Power down can be entered from the both banks idle state or row active state.

2. Must be legal command as defined in Operative Command Table.

**Remark** H = High level, L = Low level, x = High or Low level (Don't care)

4.6 Command Truth Table for Two Banks Operation

/CS	/RAS	/CAS	/WE	DSF	A9(BA)	A8	A7 - A0	Action	"FROM" State <sup>Note1</sup>	"TO" State <sup>Note2</sup>
H	x	x	x	x	x	x	x	NOP	Any	Any
L	H	H	H	L	x	x	x	NOP	Any	Any
L	H	H	L	L	x	x	x	BST	(R/W/A)0(I/A)1	A0(I/A)1
									I0(I/A)1	I0(I/A)1
									(R/W/A)1(I/A)0	A1(I/A)0
									I1(I/A)0	I1(I/A)0
L	H	L	H	L	H	H	CA	Read	(R/W/A)1(I/A)0	RP1(I/A)0
					H	H	CA		A1(R/W)0	RP1A0
					H	L	CA		(R/W/A)1(I/A)0	R1(I/A)0
					H	L	CA		A1(R/W)0	R1A0
					L	H	CA		(R/W/A)0(I/A)1	RP0(I/A)1
					L	H	CA		A0(R/W)1	RP0A1
					L	L	CA		(R/W/A)0(I/A)1	R0(I/A)1
					L	L	CA		A0(R/W)1	R0A1
L	H	L	L	L/H	H	H	CA	Write/Block Write	(R/W/A)1(I/A)0	WP1(I/A)0
					H	H	CA		A1(R/W)0	WP1A0
					H	L	CA		(R/W/A)1(I/A)0	W1(I/A)0
					H	L	CA		A1(R/W)0	W1A0
					L	H	CA		(R/W/A)0(I/A)1	WP0(I/A)1
					L	H	CA		A0(R/W)1	WP0A1
					L	L	CA		(R/W/A)0(I/A)1	W0(I/A)1
					L	L	CA		A0(R/W)1	W0A1
L	L	H	H	L/H	H	RA	Active Row	I1Any0	A1Any0	
					L	RA		I0Any1	A0Any1	
L	L	H	L	L	x	H	x	Precharge	(R/W/A/I)0(I/A)1	I0I1
					x	H	x		(R/W/A/I)1(I/A)0	I1I0
					H	L	x		(R/W/A/I)1(I/A)0	I1(I/A)0
					H	L	x		(I/A)(R/W/A/I)0	I1(R/W/A/I)0
					L	L	x		(R/W/A/I)0(I/A)1	I0(I/A)1
					L	L	x		(I/A)0(R/W/A/I)1	I0(R/W/A/I)1
L	L	L	H	L	x	x	Refresh	I0I1	I0I1	
L	L	L	L	L	Op-Code		Mode Register Access	I0I1	I0I1	
L	L	L	L	H	Op-Code		Special Register Access	(I/A)0(I/A)1	(I/A)0(I/A)1	

Notes 1. If the μPD481850 is in a state other than above listed in the "From State" column, the command is illegal.

2. The states listed under "To" might not be entered on the next clock cycle.

Timing restrictions apply.

**Remark** H = High level, L = Low level, x = High or Low level (Don't care),

BA = Bank address (A9)

State abbreviations

I = Idle

A = Bank active

R = Read with No precharge (No precharge is posted)

W = Write with No precharge (No precharge is posted)

RP = Read with auto precharge (Precharge is posted)

WP = Write with auto precharge (Precharge is posted)

Any = Any State

X0Y1 = Bank0 is in state "X", Bank1 = in state "Y"

(X/Y)0Z1 = Z1(X/Y)0 = Bank0 is in state "X" or "Y", Bank1 is in state "Z"

## 5. Initialization

The synchronous GRAM is initialized in the power-on sequence according to the following.

- (1) To stabilize internal circuits, when power is applied, a 100 μs or longer pause must precede any signal toggling.
- (2) After the pause, both banks must be precharged using the Precharge command (The Precharge all banks command is convenient).
- (3) Once the precharge is completed and the minimum tRP is satisfied, the mode register can be programmed. After the mode register set cycle, tRSC (2 CLK minimum) pause must be satisfied as well.
- (4) Two or more CBR (Auto) refresh must be performed.

**Remarks** 1. The sequence of Mode register programming and Refresh above may be transposed.

2. CKE and DQM may be held high until the Precharge command is asserted to ensure data-bus Hi-Z.



## 6. Programming the Mode Register

The mode register is programmed by the Mode register set command using address bits A9 through A0 as data inputs. The register retains data until it is reprogrammed or the device loses power.

The mode register has four fields;

Options : A9 through A7  
/CAS latency : A6 through A4  
Wrap type : A3  
Burst length : A2 through A0

Following mode register programming, no command can be asserted before at least 2 CLK ( $t_{RSC}$ ) have elapsed.

### **/CAS Latency**

/CAS latency is the most critical of the parameters being set. It tells the device how many clocks must elapse before the data will be available.

The value is determined by the frequency of the clock and the speed grade of the device. The table on page 51 shows the relationship of /CAS latency to the clock period and the speed grade of the device.

### **Burst Length**

Burst Length is the number of words that will be output or input in a read or write cycle. After a read burst is completed, the output bus will become Hi-Z.

The burst length is programmable as 1, 2, 4, 8 or full page (256 columns).

### **Wrap Type (Burst Sequence)**

The wrap type specifies the order in which the burst data will be addressed. The  $\mu$ PD481850 supports "Sequential mode" and "Interleave mode".

The table on the page 27 shows the addressing sequence for each burst length.

7. Mode Register

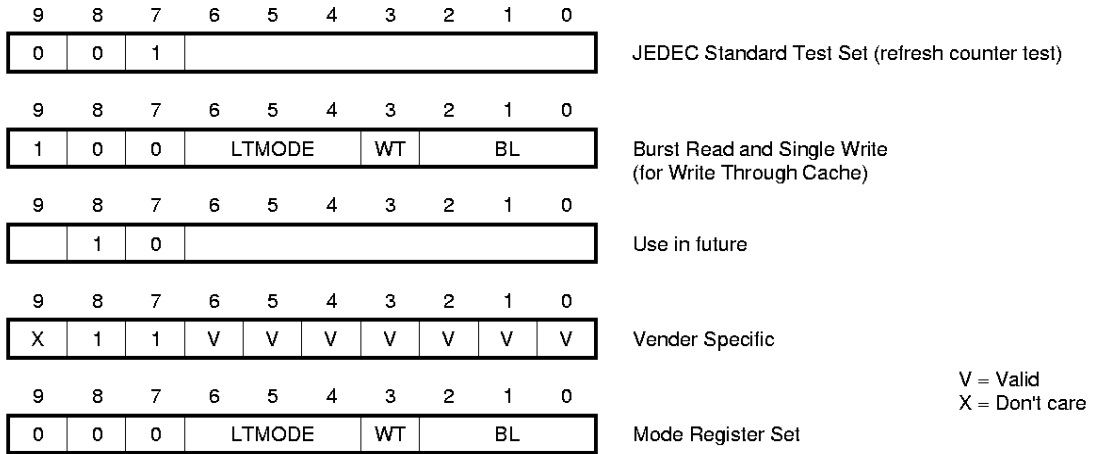

Burst length	A2-0	WT = 0	WT = 1
	000	1	1
	001	2	2
	010	4	4
	011	8	8
	100	R	R
	101	R	R
	110	R	R
111	Full page	R	

Wrap type	0	Sequential
	1	Interleave

Latency mode	A6-4	/CAS latency
	000	R
	001	R
	010	2
	011	3
	100	R
	101	R
	110	R
111	R	

Remark R : Reserved

Mode Register Write Timing

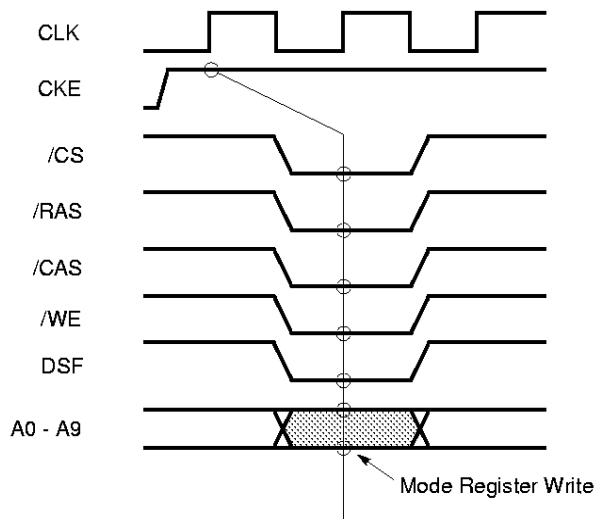

**7.1 Burst Length and Sequence**

[Burst of Two]

Starting Address (column address A0, binary)	Sequential Addressing Sequence (decimal)	Interleave Addressing Sequence (decimal)
0	0, 1	0, 1
1	1, 0	1, 0

[Burst of Four]

Starting Address (column address A1 - A0, binary)	Sequential Addressing Sequence (decimal)	Interleave Addressing Sequence (decimal)
00	0, 1, 2, 3	0, 1, 2, 3
01	1, 2, 3, 0	1, 0, 3, 2
10	2, 3, 0, 1	2, 3, 0, 1
11	3, 0, 1, 2	3, 2, 1, 0

[Burst of Eight]

Starting Address (column address A2 - A0, binary)	Sequential Addressing Sequence (decimal)	Interleave Addressing Sequence (decimal)
000	0, 1, 2, 3, 4, 5, 6, 7	0, 1, 2, 3, 4, 5, 6, 7
001	1, 2, 3, 4, 5, 6, 7, 0	1, 0, 3, 2, 5, 4, 7, 6
010	2, 3, 4, 5, 6, 7, 0, 1	2, 3, 0, 1, 6, 7, 4, 5
011	3, 4, 5, 6, 7, 0, 1, 2	3, 2, 1, 0, 7, 6, 5, 4
100	4, 5, 6, 7, 0, 1, 2, 3	4, 5, 6, 7, 0, 1, 2, 3
101	5, 6, 7, 0, 1, 2, 3, 4	5, 4, 7, 6, 1, 0, 3, 2
110	6, 7, 0, 1, 2, 3, 4, 5	6, 7, 4, 5, 2, 3, 0, 1
111	7, 0, 1, 2, 3, 4, 5, 6	7, 6, 5, 4, 3, 2, 1, 0

Full page burst is an extension of the above tables with the length being 256.

### 8. Programming the Special Register

The special register is programming by the Special register set command using address bits A9 through A0 and data bits DQ0 through DQ31. The color and mask register retain data until it is reprogrammed or the device losed power.

The special register has four fields;

- Reserved : A9 through A7
- Color register : A6
- Mask register : A5
- Reserved : A4 through A0

Following special register programming, no command can be asserted before at least 2 CLK (trsc) have elapsed.

#### 8.1 Color Register

Color register is used as write data in Block Write cycle. In Special Register set command, if A5 is "0" and A6 is "1", the color register is selected. And the data of DQ0 through DQ31 is stored to color register as color data (write data).

#### 8.2 Mask Register

Mask register is used as write mask data in Write and Block Write cycle. In Special Register set command, if A5 is "1" and A6 is "0", the mask register is selected. And the data of DQ0 through DQ31 is stored to mask register as write mask data.

#### 8.3 Special Register

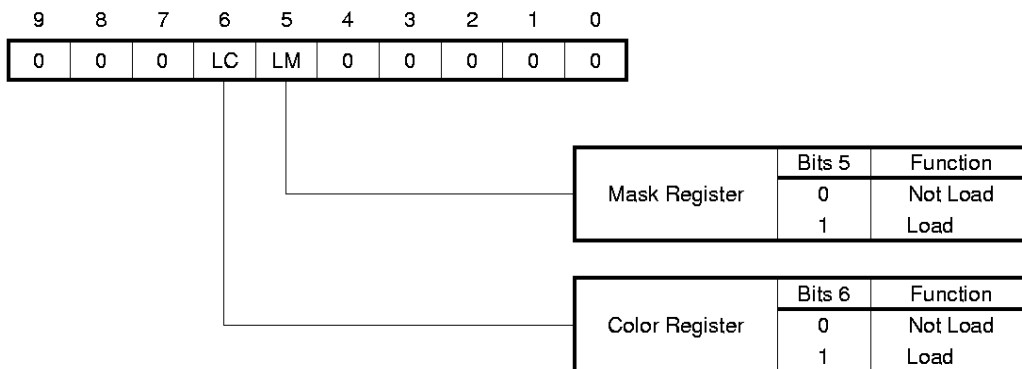

**Remark** If LC and LM are both high (1), data of Mask and Color register will be unknown.

9. Address Bits of Bank Address and Precharge

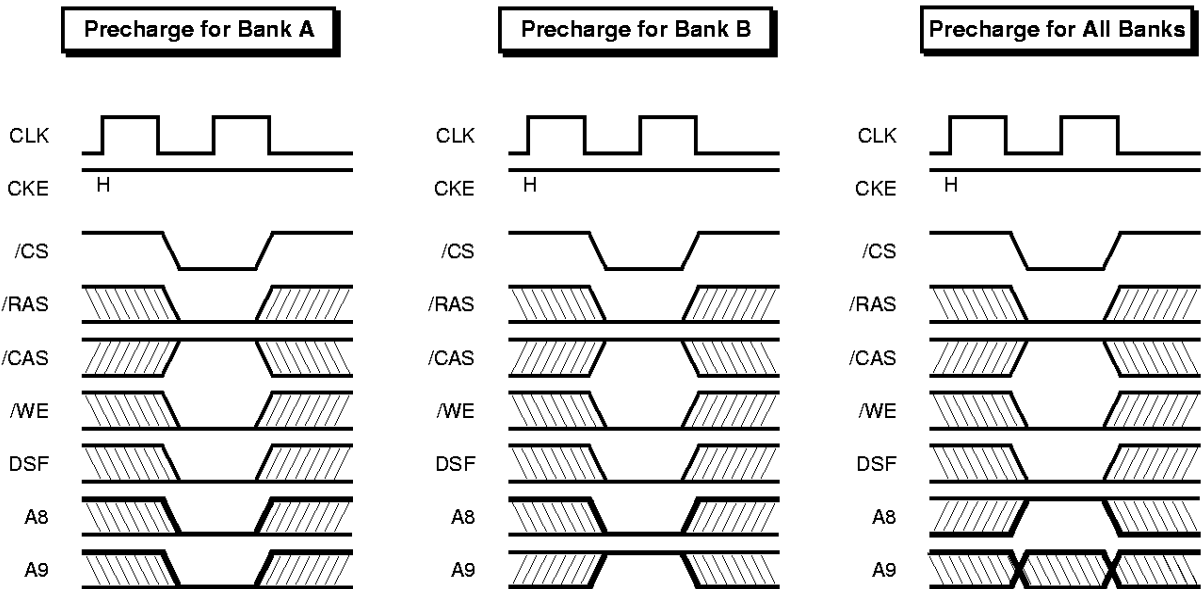
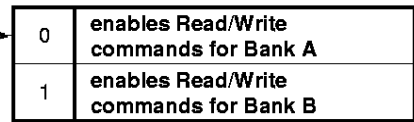
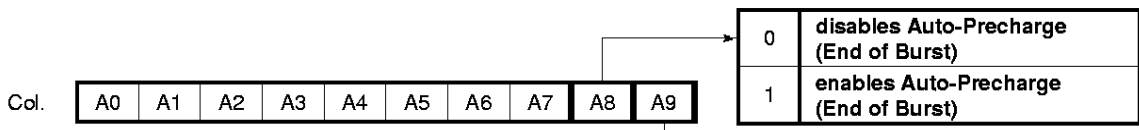
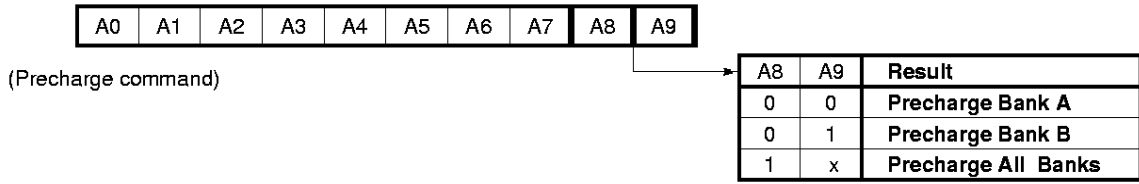
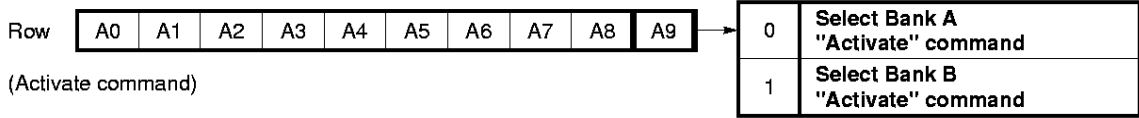

10. Precharge

The precharge command can be asserted anytime after  $t_{RAS(MIN.)}$  is satisfied.

Soon after the precharge command is asserted, precharge operation performed and the synchronous GRAM enters the idle state after  $t_{RP}$  is satisfied. The parameter  $t_{RP}$  is the time required to perform the precharge.

The earliest timing in a read cycle that a precharge command can be asserted without losing any data in the burst is as follows.

$/CAS$  latency = 2 or 3 : One clock earlier than the last read data.

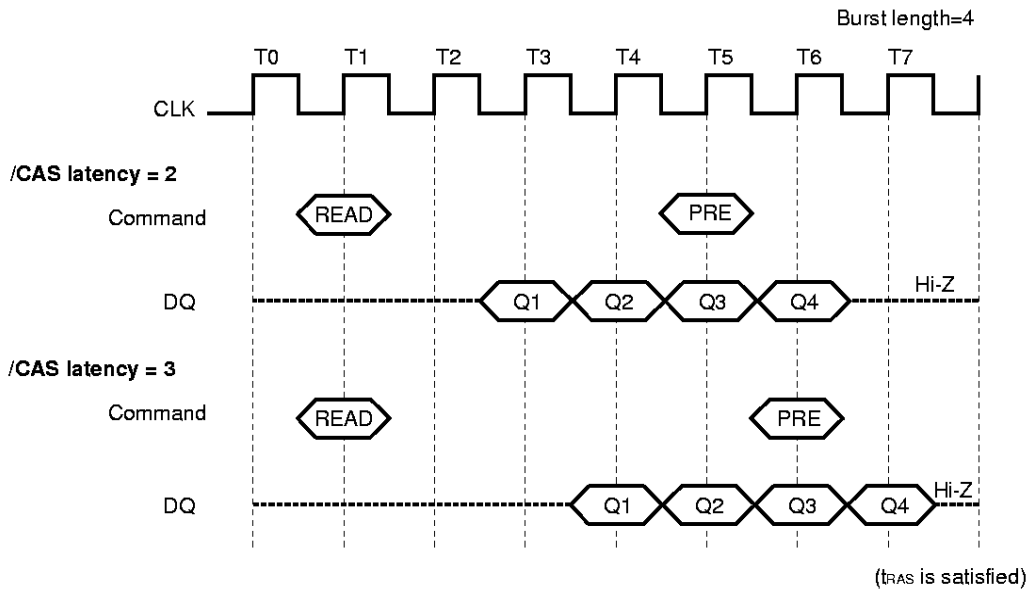

In order to write all data to the memory cell correctly, the asynchronous parameter "tdpl" must be satisfied. The  $t_{DPL(MIN.)}$  specification defines the earliest time that a precharge command can be asserted. Minimum number of clocks are calculated by dividing  $t_{DPL(MIN.)}$  with clock cycle time.

In summary, the precharge command can be asserted relative to reference clock that indicates the last data word is valid. In the following table, minus means clocks before the reference; plus means time after the reference

$/CAS$ latency	Read	Write
2	-1	+ $t_{DPL(MIN.)}$
3	-1	+ $t_{DPL(MIN.)}$

**11. Auto Precharge**

During a read or write/block write command cycle, A8 controls whether auto precharge is selected. A8 high in the read or write/block write command (Read with Auto precharge command or Write with Auto precharge command/Block Write with Auto precharge command), auto precharge is selected and begins after the burst access automatically.

When the  $t_{RAS}$  is not satisfied, the precharge does not start at above timing. And the precharge will start when the  $t_{RAS}$  is satisfied.

The clock that begins the auto precharge cycle is depend on both the /CAS latency programmed into the mode register and whether READ or WRITE/BLOCK WRITE cycle.

**11.1 Read with Auto Precharge**

When using auto precharge in READ cycle, knowing when the precharge starts is important because the next activate command to the bank being precharged cannot be executed until the precharge cycle ends. Once auto precharge has started, an activate command to the bank can be asserted after  $t_{RP}$  has been satisfied.

During READ cycle, the auto precharge begins after  $t_{RAS}$  and begins on the clock that indicates one clock earlier the last data word output during the burst is valid.

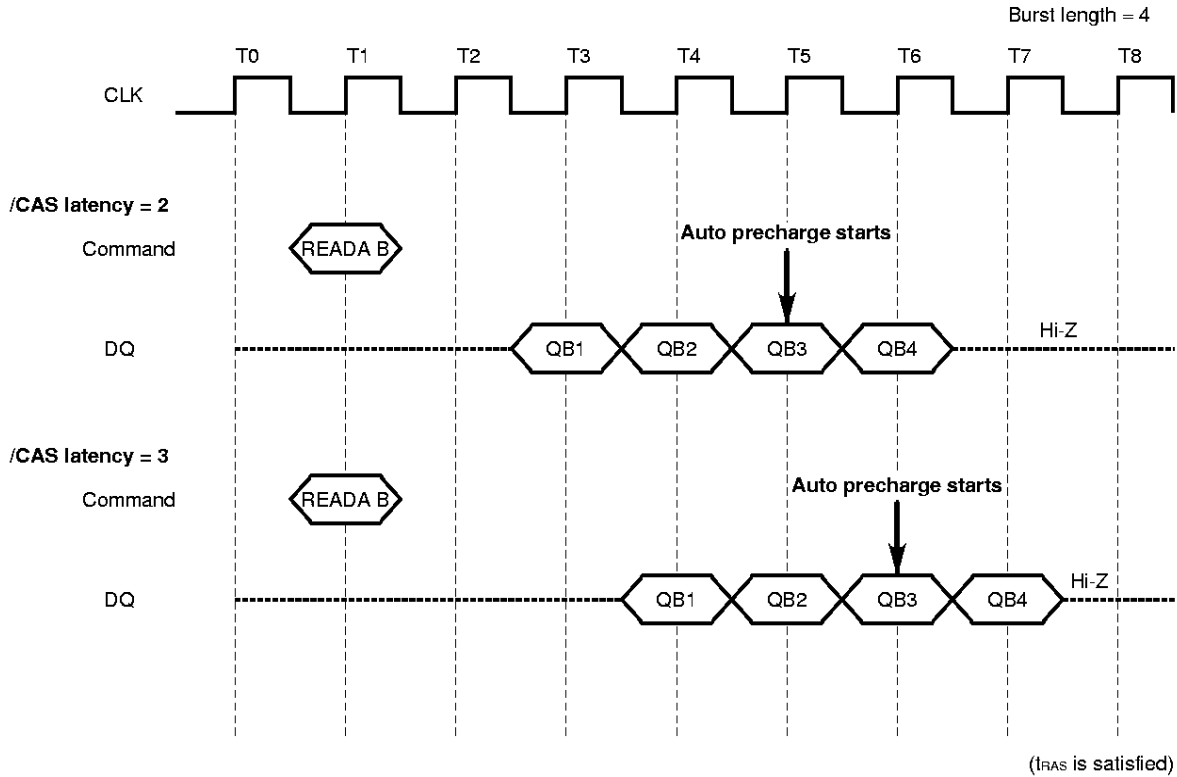

11.2 Write with Auto Precharge

In write cycle, the  $t_{DAL}$  must be satisfied to assert the all commands to the bank being precharged. And it is not necessary to know when the precharge starts. In block write cycle, the  $t_{BAL}$  must be satisfied to assert the all commands to the bank being precharged. And it is not necessary to know the precharge starts.

During WRITE cycle, the auto precharge begins after  $t_{RAS}$  and begins one clock after the last data word input to the device (/CAS latency of 2) or two clocks after (/CAS latency of 3).

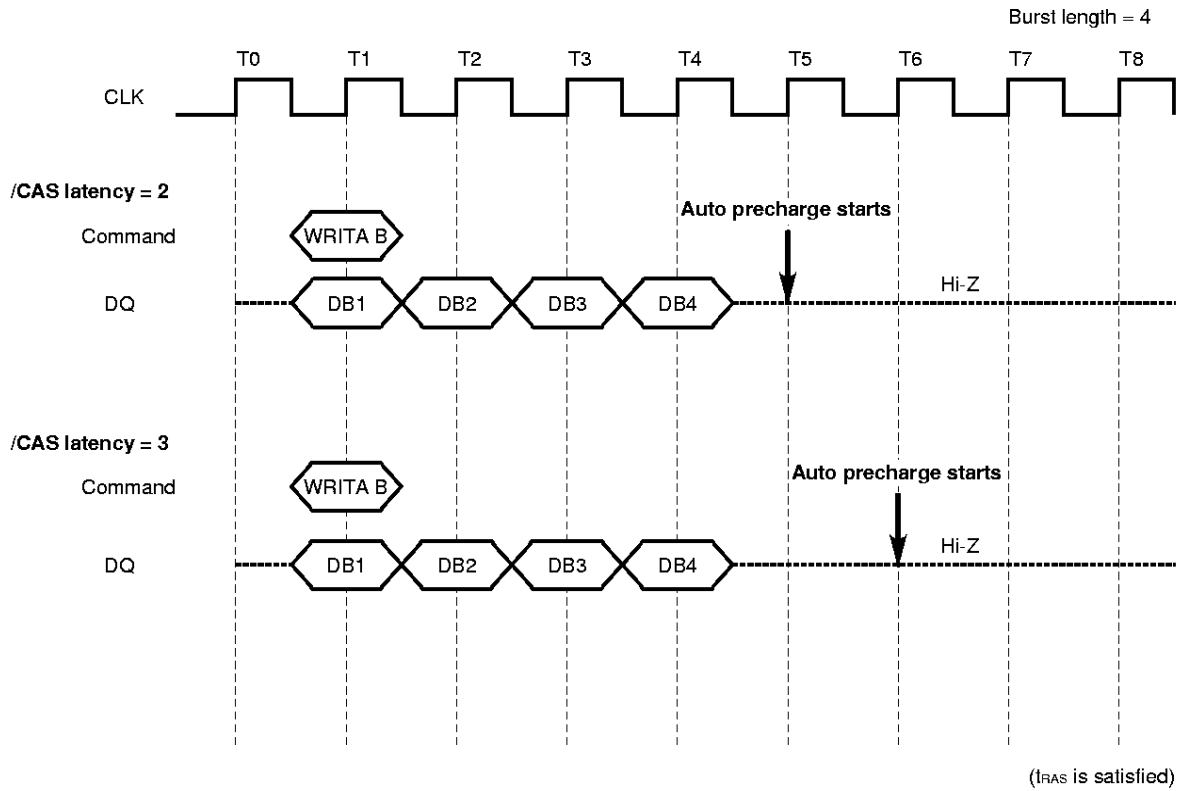



11.3 Block Write with Auto Precharge

During BLOCK WRITE cycle, the auto precharge begins two clocks after the block write command to the device (/CAS latency of 2) or three clocks after (/CAS latency of 3).

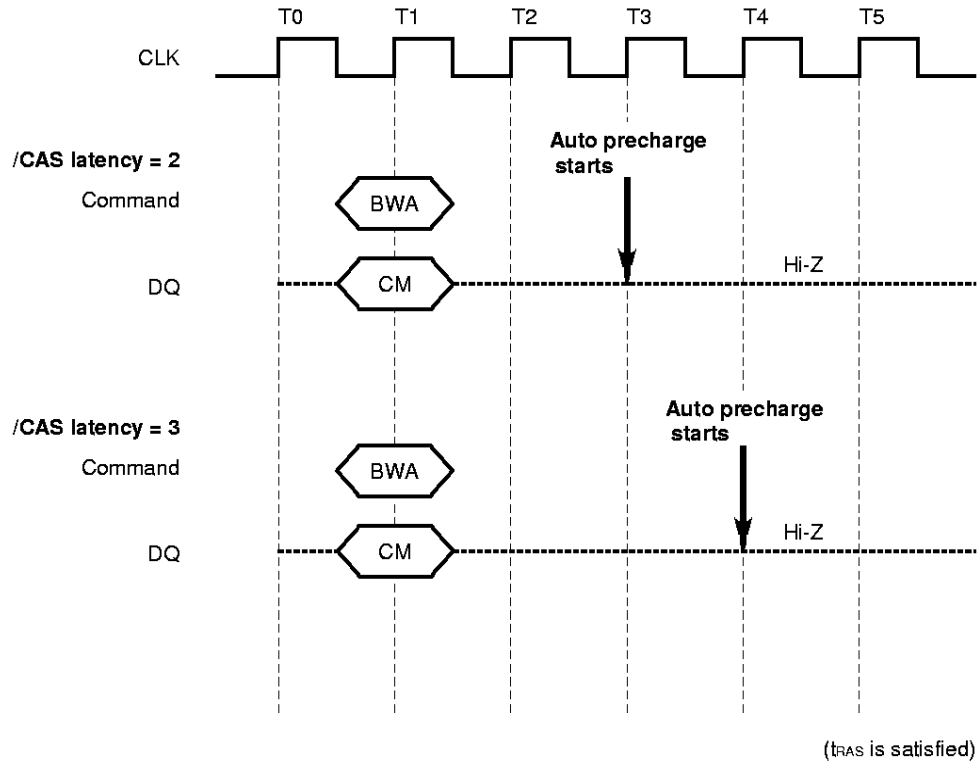

**Remark** CM : Column Mask

In summary, the auto precharge cycle begins relative to a reference clock that indicates the last data word is valid. In the table below, minus means clocks before the reference; plus means clocks after the reference.

/CAS latency	Read	Write	Block Write
2	-1	+1	+2
3	-1	+2	+3

## 12. Write/Block Write with Write Per Bit

### 12.1 Write Per Bit

The write per bit function writes data using the write mask data only in the required DQ<sub>i</sub> pins. It writes when the write mask data is "1" and prohibits writing when the data is "0". (Refer to **8.2 Mask Register**).

To use WPB operation

- (1) Execute Special register set command and set WPB data (32 bits) to mask register.
- (2) Execute Bank Activate with WPB enable command (ACTWPB) after  $t_{BSC}$  (2 CLK) period from Special register set command (SRS).
- (3) Execute Write/Block write command after  $t_{BCD}$  period from ACTWPB.

In case SRS command is executed in activate state to set new WPB data, it is necessary to take  $t_{BSC}$  (2 CLK) interval between SRS and Write/Block write command.

**Remark** Mask data = Mask register's data (WPB) + DQM<sub>i</sub>  
DQM<sub>i</sub> is prior to Mask register's data (WPB)

## 13. Block Write

### 13.1 Block Write

This cycle writes the color register data in 256 bits (8 columns x 32 I/Os) memory cell in one cycle. The memory cell range in which data can be written in one block write cycle is eight continuous columns on one row address.

This cycle controls writing in 8 columns x 8 DQ = 64 bits by DQM0 to DQM3 input. Color register data is written to the memory cell if DQM is low but not if DQM is high. DQM0 corresponds to the lowest byte (DQ0 to DQ7), DQM1 corresponds to DQ8 to DQ15, DQM2 corresponds to DQ16 to DQ23, DQM3 corresponds to DQ24 to DQ31.

Any column of the eight columns can be selected and writing prohibited. Determine whether to write or prohibit writing according to the data selected for column. (Refer to **13.2 Column Mask**)

To use Block write operation

- (1) Execute Special register set command and set color data (32 bits) to color register.
- (2) Execute Bank Activate (ACT) or Bank Activate with WPB enable command (ACTWPB) after  $t_{BSC}$  (2 CLK) period from SRS.
- (3) Execute Block write command after  $t_{BCD}$  period from ACT or ACTWPB.

In case new Write/Block write is executed or, it is necessary to take  $t_{BWC}$  interval from Block Write command to new Write/Block write command.

**13.2 Column Mask**

In block write cycle any column of the eight columns can be selected and writing prohibited. Determine which column to select according to the DQi pin to which the data selected for the column is to be input. Refer to the table below.

Column address <small>Note</small>	Column address and corresponding DQ pin				Column select data (DQi)	Writing
	A2	A1	A0	DQi		
i (1st column)	0	0	0	DQ0/DQ8/	1	Yes
				DQ16/DQ24	0	No
i+1 (2nd column)	0	0	1	DQ1/DQ9/	1	Yes
				DQ17/DQ25	0	No
i+2 (3rd column)	0	1	0	DQ2/DQ10/	1	Yes
				DQ18/DQ26	0	No
i+3 (4th column)	0	1	1	DQ3/DQ11/	1	Yes
				DQ19/DQ27	0	No
i+4 (5th column)	1	0	0	DQ4/DQ12/	1	Yes
				DQ20/DQ28	0	No
i+5 (6th column)	1	0	1	DQ5/DQ13/	1	Yes
				DQ21/DQ29	0	No
i+6 (7th column)	1	1	0	DQ6/DQ14/	1	Yes
				DQ22/DQ30	0	No
i+7 (8th column)	1	1	1	DQ7/DQ15/	1	Yes
				DQ23/DQ31	0	No

**Note** Refer to 13.3 Block Write Function.

**Remark** i is times of 8 numeric.

13.3 Block Write Function

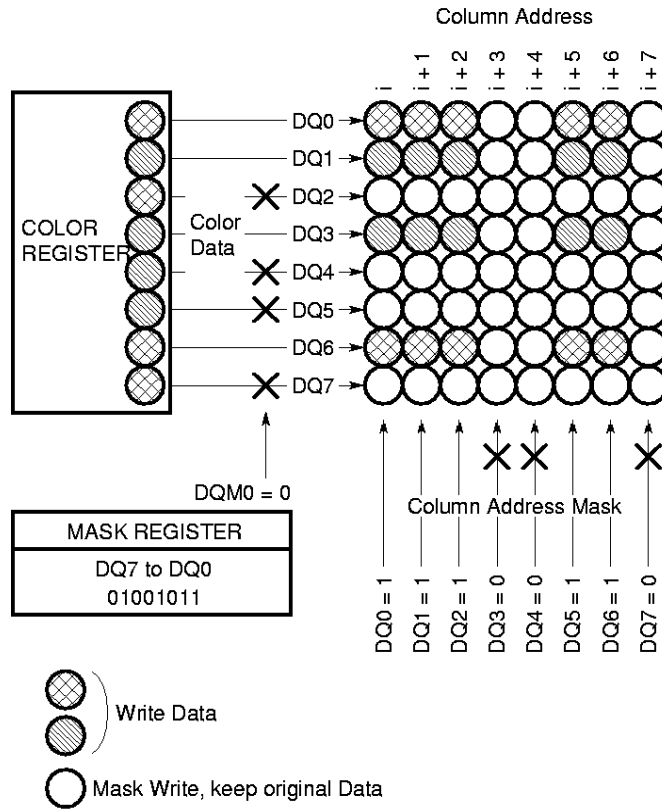

Remarks 1. i is times of 8 numeric.

2. This diagram shows only for DQ0 - DQ7. The other DQ is similar as this.

**14. Read/Write Command Interval**

**14.1 Read to Read Command Interval**

During READ cycle, when new Read command is asserted, it will be effective after /CAS latency, even if the previous READ operation does not completed. READ will be interrupted by another READ.

The interval between the commands is minimum 1 cycle. Each Read command can be asserted in every clock without any restriction.

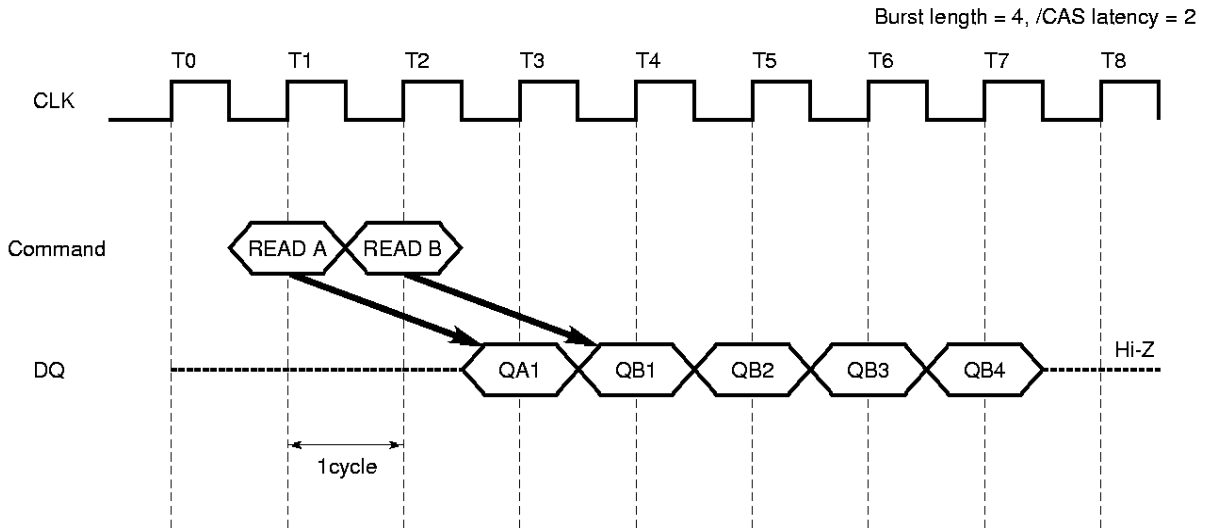

**14.2 Write to Write Command Interval**

During WRITE cycle, when new Write command is asserted, the previous burst will terminate and the new burst will begin with a new Write command. WRITE will be interrupted by another WRITE.

The interval between the commands is minimum 1 cycle. Each Write command can be asserted in every clock without any restriction.

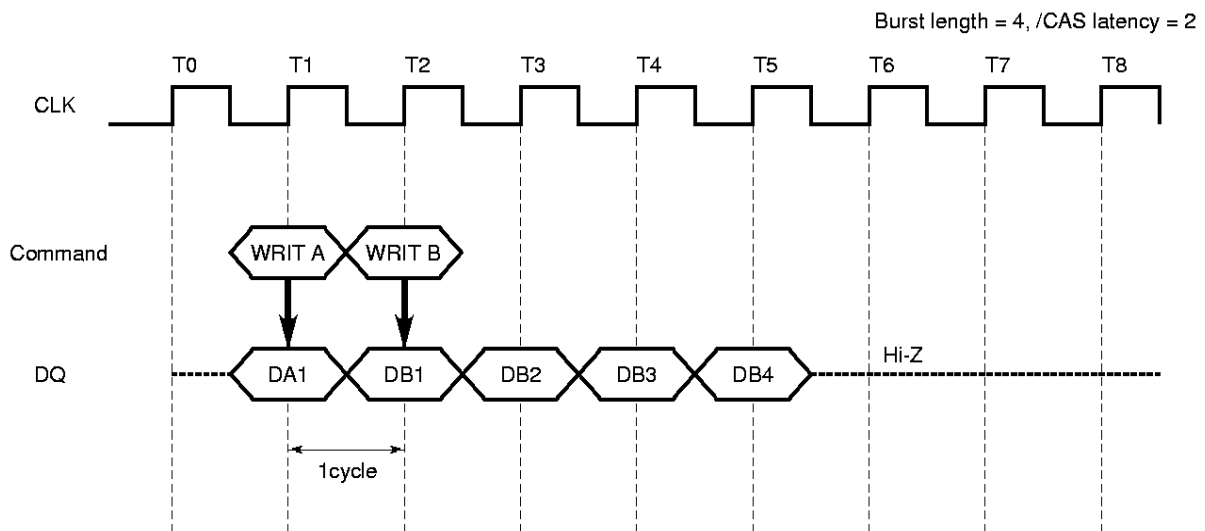

14.3 Write to Read Command Interval

Write command and Read command interval is also 1 cycle.

Only the write data before Read command will be written.

The data bus must be Hi-Z at least one cycle prior to the first Dour.

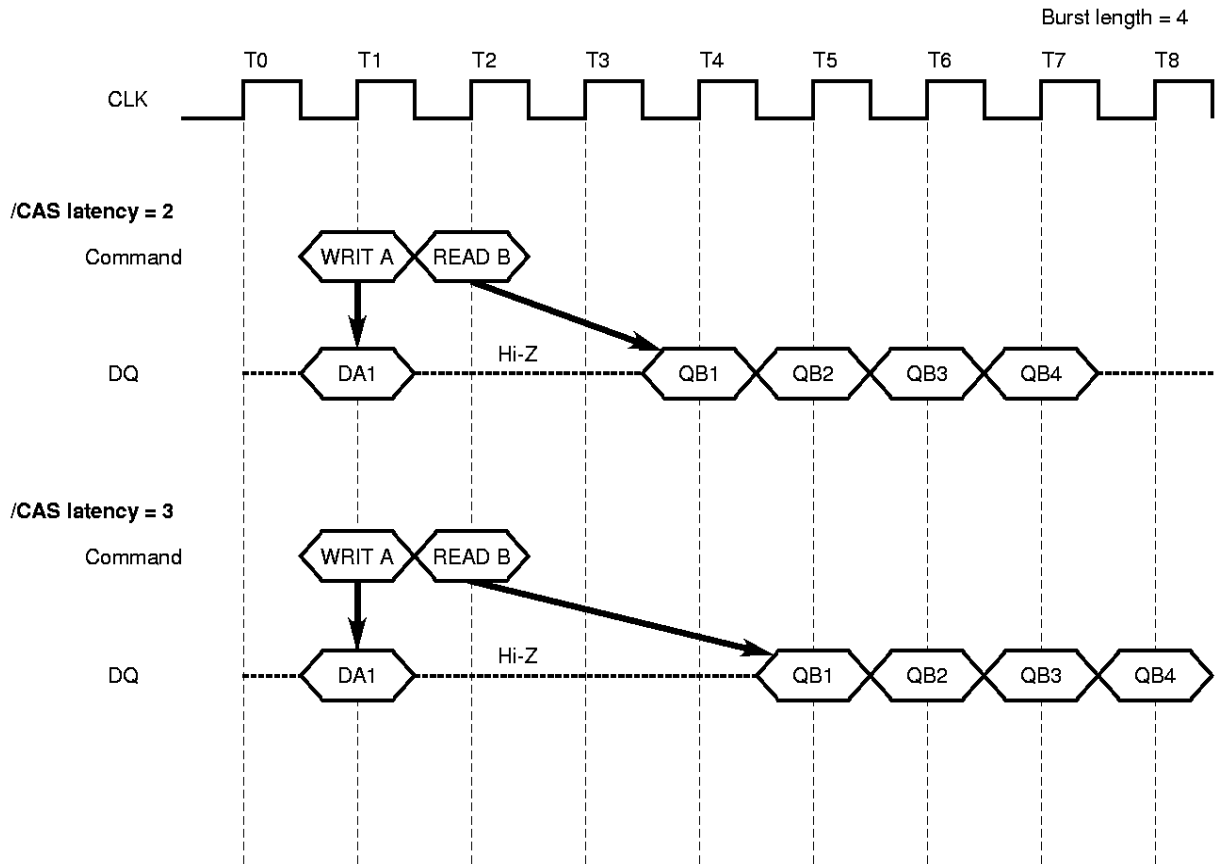

**14.4 Block Write to Write or Write/Block Write Command Interval**

The interval between BLOCK WRITE and new BLOCK WRITE or WRITE is  $t_{bwc}$  or minimum 1 cycle. If  $t_{clk}$  is less than  $t_{bwc}$ , NOP command should be issued for the cycle between BLOCK WRITE and the following WRITE or new BLOCK WRITE.

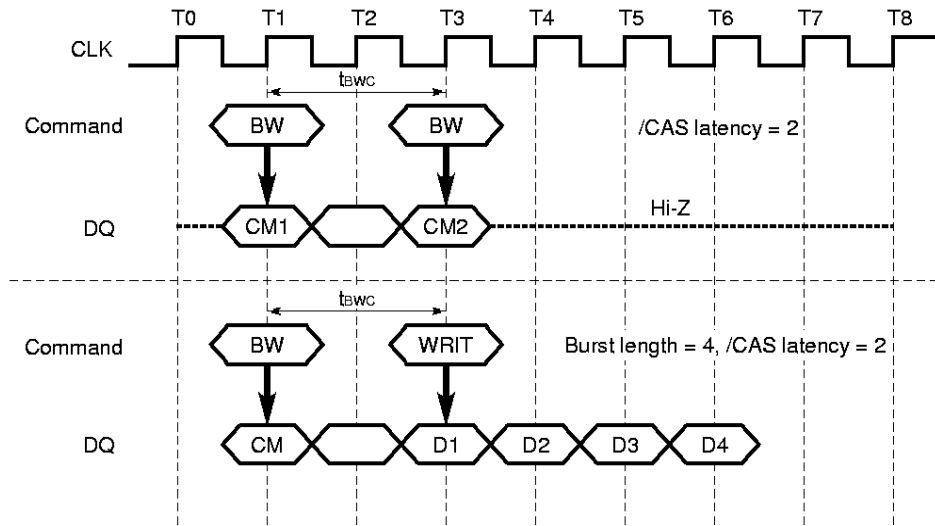

**14.5 Block Write to Read Command Interval**

BLOCK WRITE command and READ command is also  $t_{bwc}$  or minimum 1 cycle. The data bus must be Hi-Z at least one cycle prior to the first Dout.

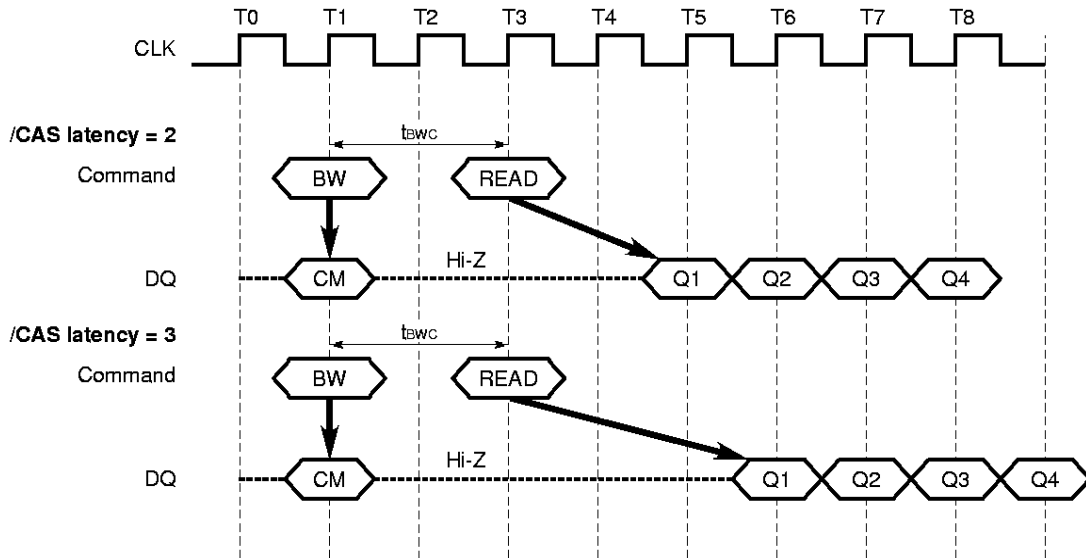

14.6 Read to Write/Block Write Command Interval

During READ cycle, Read can be interrupted by WRITE/BLOCK WRITE.

The READ and WRITE/BLOCK WRITE command interval is minimum 1 cycle. There is a restriction to avoid data conflict. The Data bus must be Hi-Z using DQM before WRITE/BLOCK WRITE.

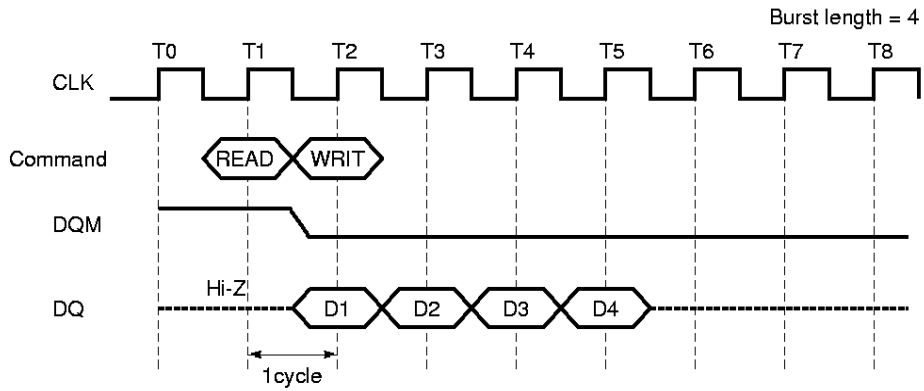

Read can be interrupted by WRITE/BLOCK WRITE. DQM must be High at least 3 clocks prior to the Write command.

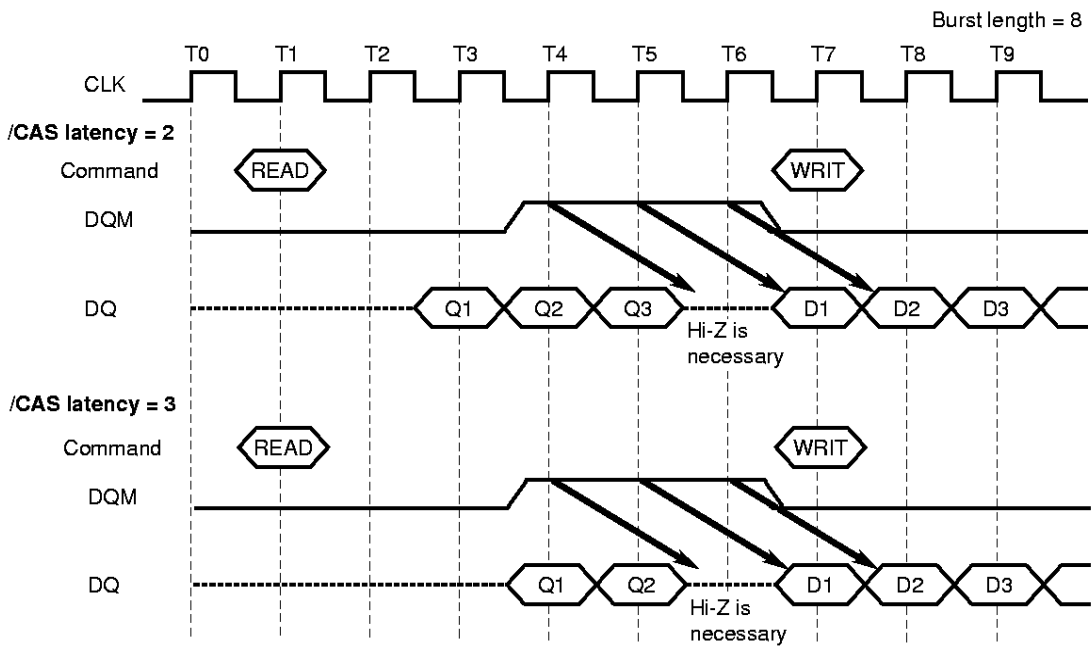



**15. Burst Termination**

Burst termination is to terminate a burst operation other than using a read or write command.

**15.1 Burst Stop Command in Full Page**

Burst Stop command is operated only in case full page burst mode. During the other burst mode, Burst Stop command is NOP.

During full page burst read cycle, when the burst stop command is asserted, the burst read data are terminated and the data bus goes to high-impedance after the /CAS latency from the burst stop command.

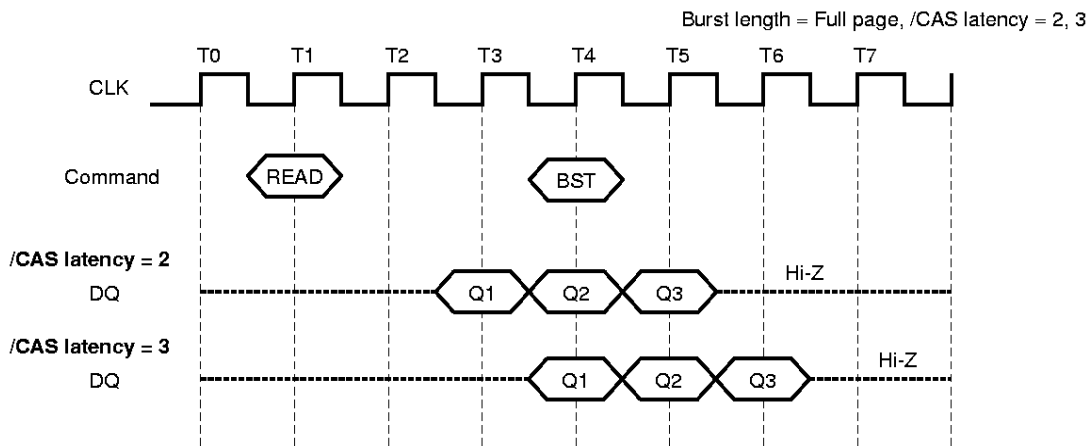

During full page burst write cycle, when the burst stop command is asserted, the burst read data are terminated and data bus goes to high-impedance at the same clock with the burst stop command.

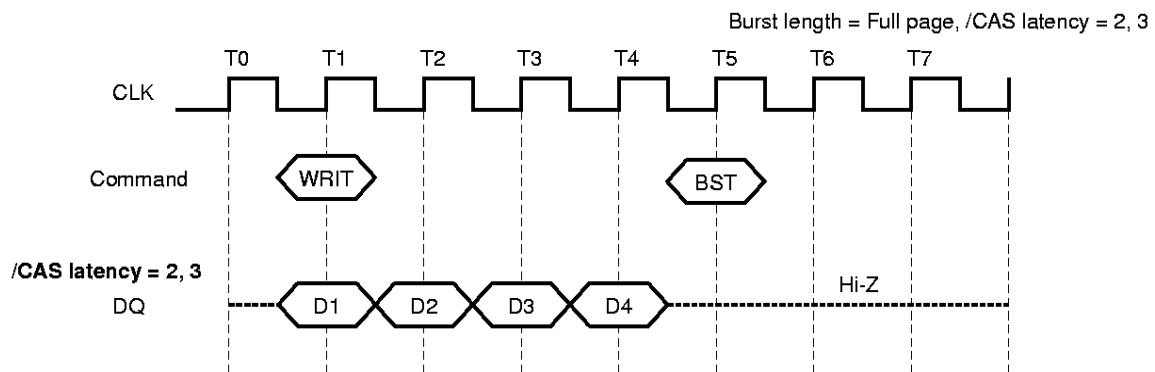

15.2 Precharge Termination

15.2.1 Precharge Termination in READ Cycle

During READ cycle, the burst read operation is terminated by a precharge command.  
 When the precharge command is asserted, the burst read operation is terminated and precharge starts.  
 When the precharge command is asserted,  $t_{RAS}$  must be satisfied.  
 The same bank can be activated again after  $t_{RP}$  from the precharge command.

When /CAS latency is 2, the read data will remain valid until one clock after the precharge command.

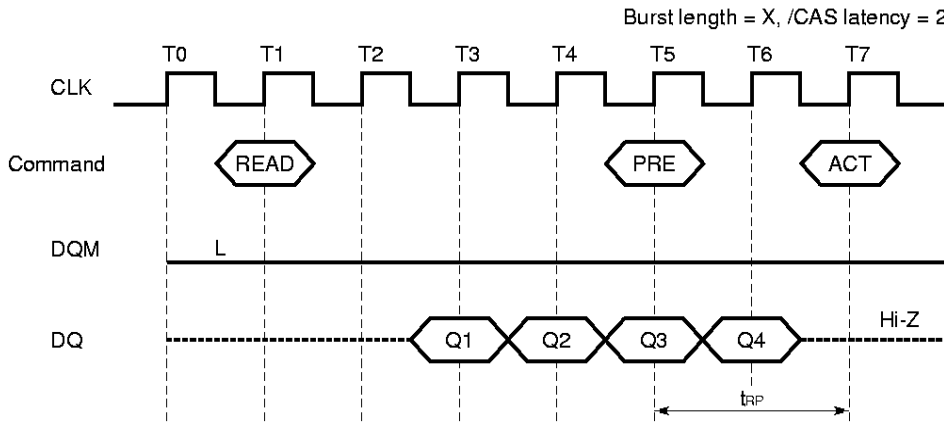

When /CAS latency is 3, the read data will remain valid until two clocks after the precharge command.

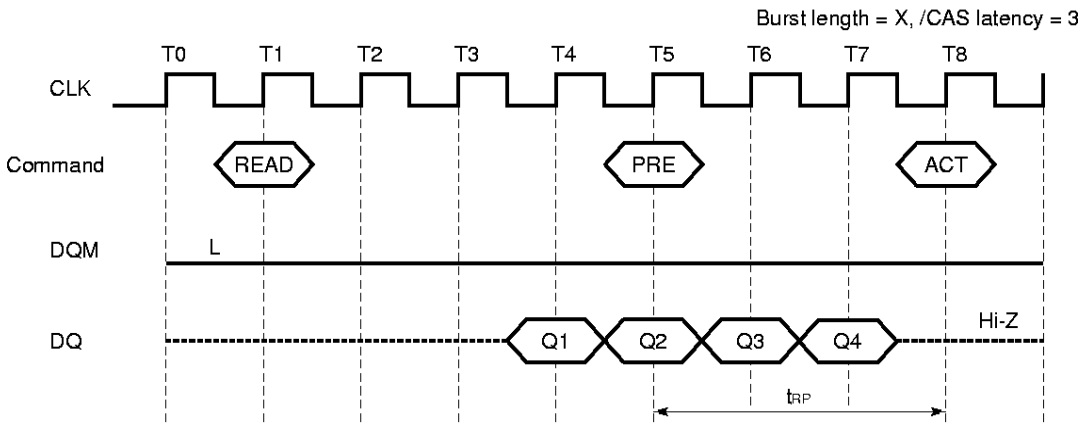

**15.2.2 Precharge Termination in WRITE cycle**

During WRITE cycle, the burst write operation is terminated by a precharge command.

When the precharge command is asserted, the burst write operation is terminated and precharge starts.

The same bank can be activated again after  $t_{RP}$  from the precharge command.

The DQM must be high to mask invalid data in.

When /CAS latency is 2, the write data written prior to the precharge command will be correctly stored. However, invalid data may be written at the same clock as the precharge command. To prevent this from happening, DQM must be high at the same clock as the precharge command. This will mask the invalid data.

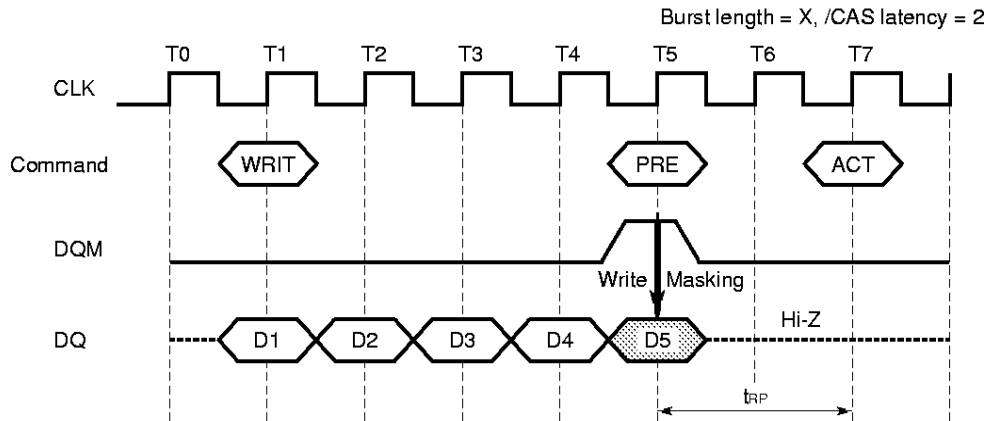

When /CAS latency is 3, the write data written prior to the precharge command will be correctly stored.

However, invalid data may be written at the same clock as the precharge command. To prevent this from happening, DQM must be high at the same clock as the precharge command. This will mask the invalid data.

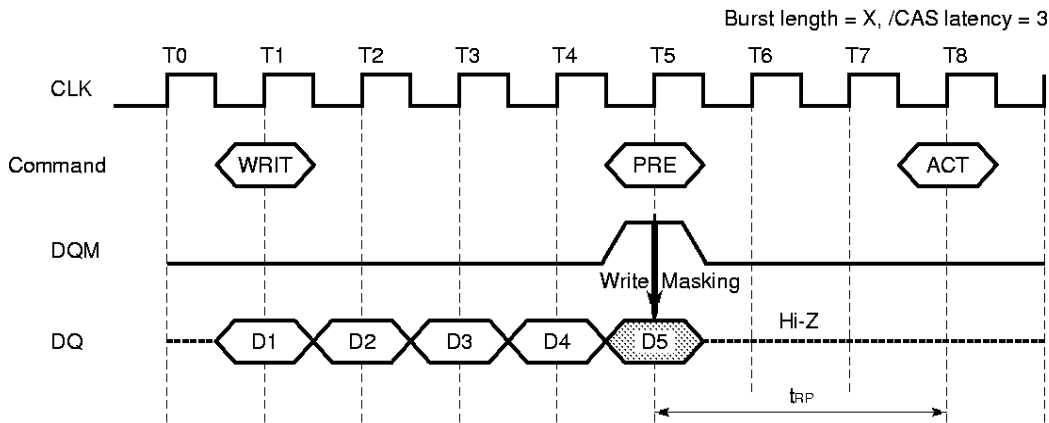

**16. Electrical Specifications**

- All voltages are referenced to V<sub>SS</sub> (GND).
- After power up, wait more than 100 μs and then, execute **Power on sequence and Auto Refresh** before proper device operation is achieved.

**Absolute Maximum Ratings**

Parameter	Symbol	Condition	Rating	Unit
Voltage on power supply pin relative to GND	V <sub>CC</sub>		-1.0 to +4.6	V
Voltage on input pin relative to GND	V <sub>I</sub>		-1.0 to +4.6	V
Short circuit output current	I <sub>O</sub>		50	mA
Power dissipation	P <sub>D</sub>		1	W
Operating ambient temperature	T <sub>A</sub>		0 to +70	°C
Storage temperature	T <sub>sig</sub>		-55 to +125	°C

**Caution** Exposing the device to stress above those listed in **Absolute Maximum Ratings** could cause permanent damage. The device is not meant to be operated under conditions outside the limits described in the operational section of this specification. Exposure to **Absolute Maximum Rating** conditions for extended periods may affect device reliability.

**Recommended Operating Conditions**

Parameter	Symbol	Condition	MIN.	TYP.	MAX.	Unit
Supply voltage	V <sub>CC</sub>		3.0	3.3	3.6	V
High level input voltage	V <sub>IH</sub>		2.0		V <sub>CC</sub> + 0.3	V
Low level input voltage	V <sub>IL</sub>		-0.3		+0.8	V
Operating ambient temperature	T <sub>A</sub>		0		70	°C

**Capacitance (T<sub>A</sub> = 25 °C, f = 1 MHz)**

Parameter	Symbol	Test condition	MIN.	TYP.	MAX.	Unit
Input capacitance	C <sub>I1</sub>	A0 - A9	2		4	pF
	C <sub>I2</sub>	CLK, CKE, /CS, /RAS, /CAS, /WE, DSF, DQM0 - DQM3	2		4	
Data input/output capacitance	C <sub>I/O</sub>	DQ0 - DQ31	2		5	pF

DC Characteristics (Recommended Operating Conditions unless otherwise noted)

Parameter	Symbol	Test condition	MIN.	MAX.	Unit	Notes	
Operating current	I <sub>CC1</sub>	Burst length = 1 t <sub>RC</sub> ≥ t <sub>RC(MIN.)</sub> , I <sub>O</sub> = 0 mA	-A10	105	mA	1	
			-A12	90			
Precharge standby current in power down mode	I <sub>CC2P</sub>	CKE ≤ V <sub>IL(MAX.)</sub> , t <sub>CK</sub> = 15 ns		7	mA		
	I <sub>CC2PS</sub>	CKE ≤ V <sub>IL(MAX.)</sub> , t <sub>CK</sub> = ∞		6			
Precharge standby current in non power down mode	I <sub>CC2N</sub>	CKE ≥ V <sub>IH(MIN.)</sub> , t <sub>CK</sub> = 15 ns, /CS ≥ V <sub>IH(MIN.)</sub> , Input signals are changed one time during 30 ns.		36	mA		
	I <sub>CC2NS</sub>	CKE ≥ V <sub>IH(MIN.)</sub> , t <sub>CK</sub> = ∞ Input signals are stable.		22			
Active standby current in power down mode	I <sub>CC3P</sub>	CKE ≤ V <sub>IL(MAX.)</sub> , t <sub>CK</sub> = 15 ns		7	mA		
	I <sub>CC3PS</sub>	CKE ≤ V <sub>IL(MAX.)</sub> , t <sub>CK</sub> = ∞		6			
Active standby current in non power down mode	I <sub>CC3N</sub>	CKE ≥ V <sub>IH(MIN.)</sub> , t <sub>CK</sub> = 15 ns, /CS ≥ V <sub>IH(MIN.)</sub> , Input signals are changed one time during 30 ns.		36	mA		
	I <sub>CC3NS</sub>	CKE ≥ V <sub>IH(MIN.)</sub> , t <sub>CK</sub> = ∞ Input signals are stable.		22			
Operating current (Burst mode)	I <sub>CC4</sub>	t <sub>CK</sub> ≥ t <sub>CK(MIN.)</sub> I <sub>O</sub> = 0 mA	/CAS latency = 2	-A10	155	mA	2
				-A12	130		
			/CAS latency = 3	-A10	200		
				-A12	170		
Refresh current	I <sub>CC5</sub>	t <sub>RC</sub> ≥ t <sub>RC(MIN.)</sub>	-A10	85	mA	3	
			-A12	80			
Self refresh current	I <sub>CC6</sub>	CKE ≤ 0.2 V		6	mA		
Operating current (Block Write Mode)	I <sub>CC7</sub>	t <sub>CK</sub> ≥ t <sub>CK(MIN.)</sub> , I <sub>O</sub> = 0 mA, /CAS cycle = 20 ns		250	mA		
Input leakage current	I <sub>I(L)</sub>	V <sub>I</sub> = 0 to 3.6 V, All other pins not under test = 0 V	-5.0	+5.0	μA		
Output leakage current	I <sub>O(L)</sub>	D <sub>OUT</sub> is disabled, V <sub>O</sub> = 0 to 3.6 V	-5.0	+5.0	μA		
High level output voltage	V <sub>OH</sub>	I <sub>O</sub> = -2.0 mA	2.4		V		
Low level output voltage	V <sub>OL</sub>	I <sub>O</sub> = +2.0 mA		0.4	V		

- Notes**
- I<sub>CC1</sub> depends on output loading and cycle rates. Specified values are obtained with the output open. In addition to this, I<sub>CC1</sub> is measured on condition that addresses are changed only one time during t<sub>CK(MIN.)</sub>.
  - I<sub>CC4</sub> depends on output loading and cycle rates. Specified values are obtained with the output open. In addition to this, I<sub>CC4</sub> is measured on condition that addresses are changed only one time during t<sub>CK(MIN.)</sub>.
  - I<sub>CC5</sub> is measured on condition that addresses are changed only one time during t<sub>CK(MIN.)</sub>.

AC Characteristics (Recommended Operating Conditions unless otherwise noted)

AC Characteristics Test Conditions

- AC measurements assume  $t_r = 1$  ns.
- Reference level for measuring timing of input signals is 1.4 V. Transition times are measured between  $V_{IH}$  and  $V_{IL}$ .
- If  $t_r$  is longer than 1 ns, reference level for measuring timing of input signals is  $V_{IH(MIN.)}$  and  $V_{IL(MAX.)}$ .
- An access time is measured at 1.4 V.

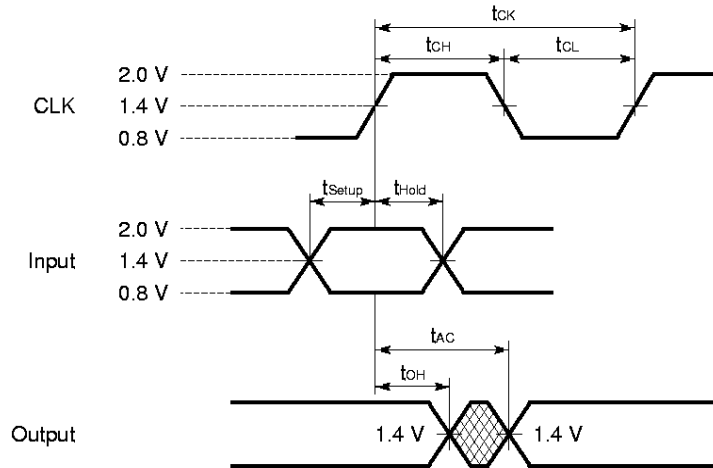

**Synchronous Characteristics**

Parameter		Symbol	-A10		-A12		Unit	Note
			MIN.	MAX.	MIN.	MAX.		
Clock cycle time	/CAS latency = 3	t <sub>CK3</sub>	10	(100MHz)	12	(83MHz)	ns	
	/CAS latency = 2	t <sub>CK2</sub>	15	(66MHz)	18	(55MHz)	ns	
Access time from CLK	/CAS latency = 3	t <sub>AC3</sub>		9		11	ns	1
	/CAS latency = 2	t <sub>AC2</sub>		12		15	ns	1
CLK high level width		t <sub>CH</sub>	3.5		4		ns	
CLK low level width		t <sub>CL</sub>	3.5		4		ns	
Data-out hold time		t <sub>OH</sub>	4		4		ns	1
Data-out low-impedance time		t <sub>LZ</sub>	0		0		ns	
Data-out high-impedance time	/CAS latency = 3	t <sub>HZ3</sub>	4	8	4	8	ns	
	/CAS latency = 2	t <sub>HZ2</sub>	4	11	4	11	ns	
Data-in setup time		t <sub>DS</sub>	3		3.5		ns	
Data-in hold time		t <sub>DH</sub>	1		1.5		ns	
Address setup time		t <sub>AS</sub>	3		3.5		ns	
Address hold time		t <sub>AH</sub>	1		1.5		ns	
CKE setup time		t <sub>CKS</sub>	3		3.5		ns	
CKE hold time		t <sub>CKH</sub>	1		1.5		ns	
CKE setup time (Power down exit)		t <sub>CKSP</sub>	3		3.5		ns	
Command (/CS, /RAS, /CAS, /WE, DSF, DQM) setup time		t <sub>CMS</sub>	3		3.5		ns	
Command (/CS, /RAS, /CAS, /WE, DSF, DQM) hold time		t <sub>CMH</sub>	1		1.5		ns	

**Note 1.** Loading capacitance is 30 pF.

**Asynchronous Characteristics**

Parameter	Symbol	-A10		-A12		Unit	Note
		MIN.	MAX.	MIN.	MAX.		
REF to REF/ACT command period	t <sub>RC</sub>	100		120		ns	
ACT to PRE command period	t <sub>RAS</sub>	70	120,000	84	120,000	ns	
PRE to ACT command period	t <sub>RP</sub>	30		36		ns	
Delay time ACT to READ/WRITE command	t <sub>RCD</sub>	30		36		ns	
ACT(0) to ACT(1) command period	t <sub>RRD</sub>	20		24		ns	
Data-in to PRE command period	/CAS latency = 3 t <sub>DPL3</sub>	10		12		ns	
	/CAS latency = 2 t <sub>DPL2</sub>	15		18		ns	
Data-in to ACT(REF) command period (Auto precharge)	/CAS latency = 3 t <sub>DAL3</sub>	2CLK + 30		2CLK + 36		ns	
	/CAS latency = 2 t <sub>DAL2</sub>	1CLK + 30		1CLK + 36		ns	
Block write cycle time	t <sub>BWC</sub>	20		24		ns	
Block write data-in to PRE command period	/CAS latency = 3 t <sub>BPL3</sub>	1CLK + 20		1CLK + 24		ns	
	/CAS latency = 2 t <sub>BPL2</sub>	30		36		ns	
Block write data-in Active (REF) command period (Auto precharge)	/CAS latency = 3 t <sub>BAL3</sub>	2CLK + 40		2CLK + 48		ns	
	/CAS latency = 2 t <sub>BAL2</sub>	1CLK + 40		1CLK + 48		ns	
Mode register set cycle time	t <sub>RSC</sub>	2		2		CLK	
Transition time	t <sub>T</sub>	1	30	1	30	ns	
Refresh time	t <sub>REF</sub>		16		16	ms	



**16.1 AC Parameters for Read/Write Cycles**  
**AC Parameters for Read Timing (Burst length = 2, /CAS latency = 2)**

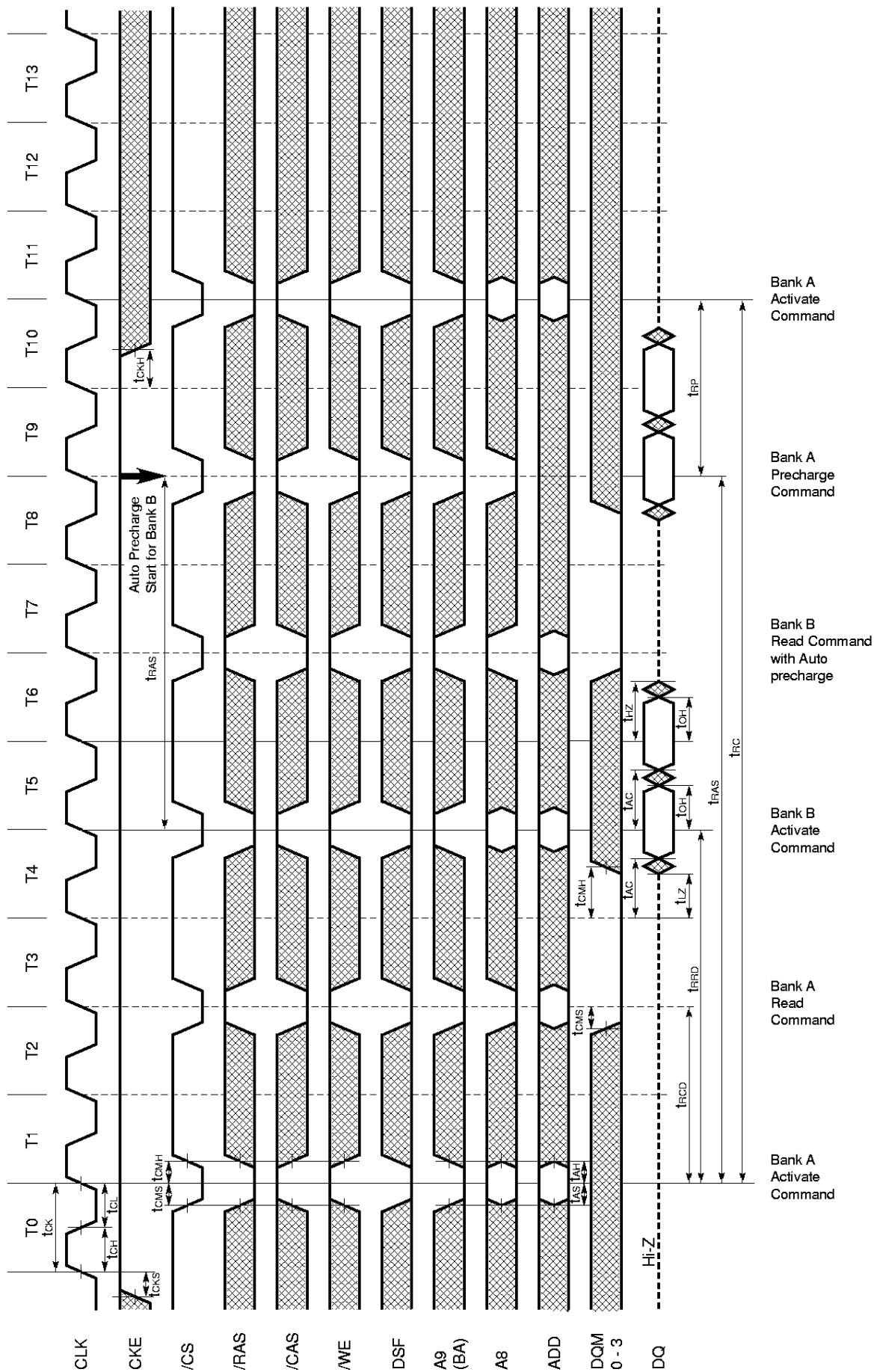

AC Parameters for Write Timing (Burst length = 4, /CAS latency = 2)

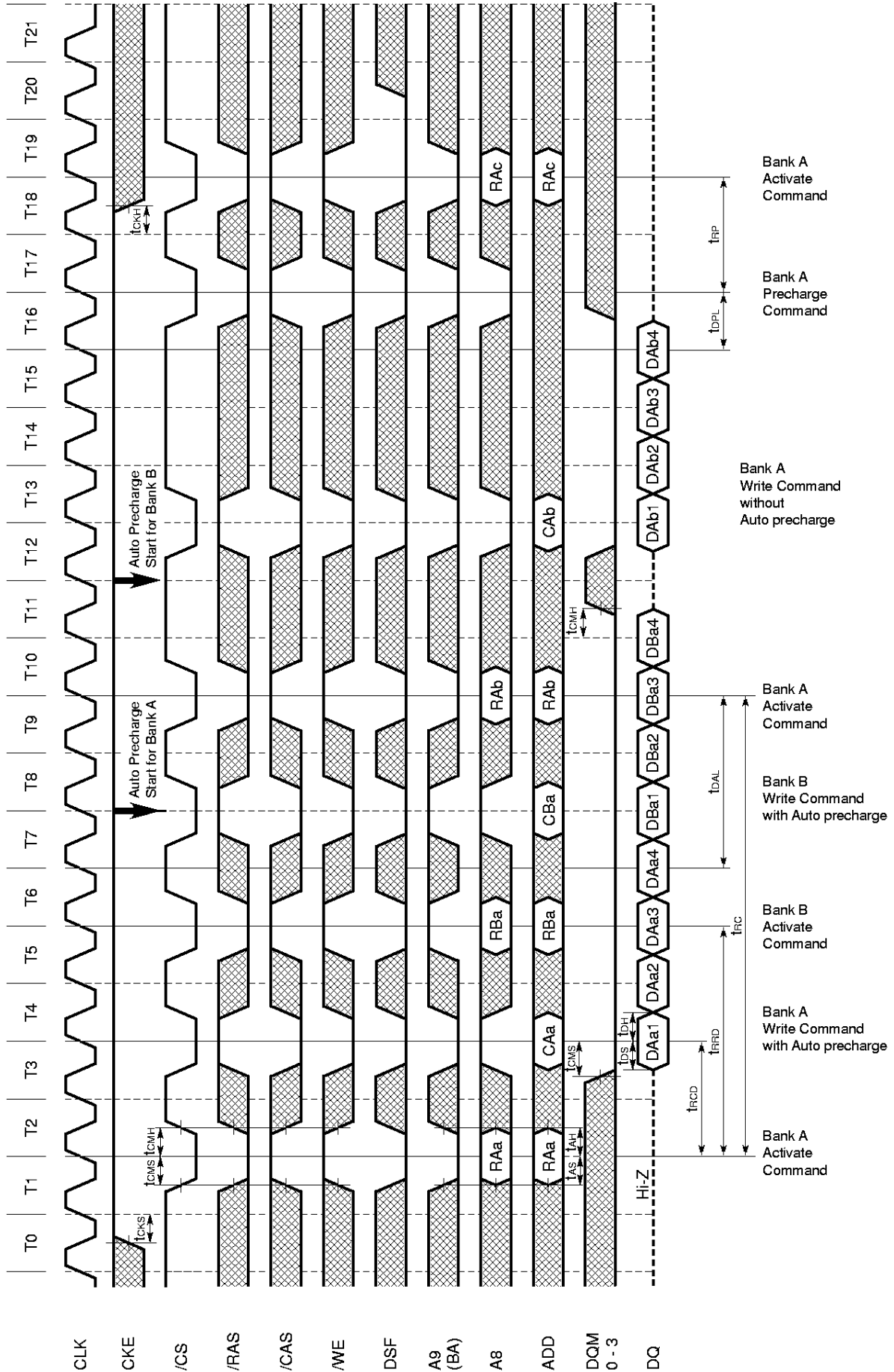

**16.2 Relationship between Frequency and Latency**

Speed version	-A10		-A12	
Clock cycle time [ns]	10	15	12	18
Frequency [MHz]	100	66	83	55
/CAS latency	3	2	3	2
[t <sub>RCD</sub> ]	3	2	3	2
/RAS latency (/CAS latency + [t <sub>RCD</sub> ])	6	4	6	4
[t <sub>RC</sub> ]	10	7	10	7
[t <sub>RAS</sub> ]	7	5	7	5
[t <sub>RRD</sub> ]	3	2	3	2
[t <sub>RP</sub> ]	3	2	3	2
[t <sub>DPL</sub> ]	1	1	1	1
[t <sub>DAL</sub> ]	5	3	5	3

16.3 /CS Function

/CS function (Only /CS signal needs to be asserted at minimum rate) (at 100 MHz Burst length = 4, /CAS latency = 3)

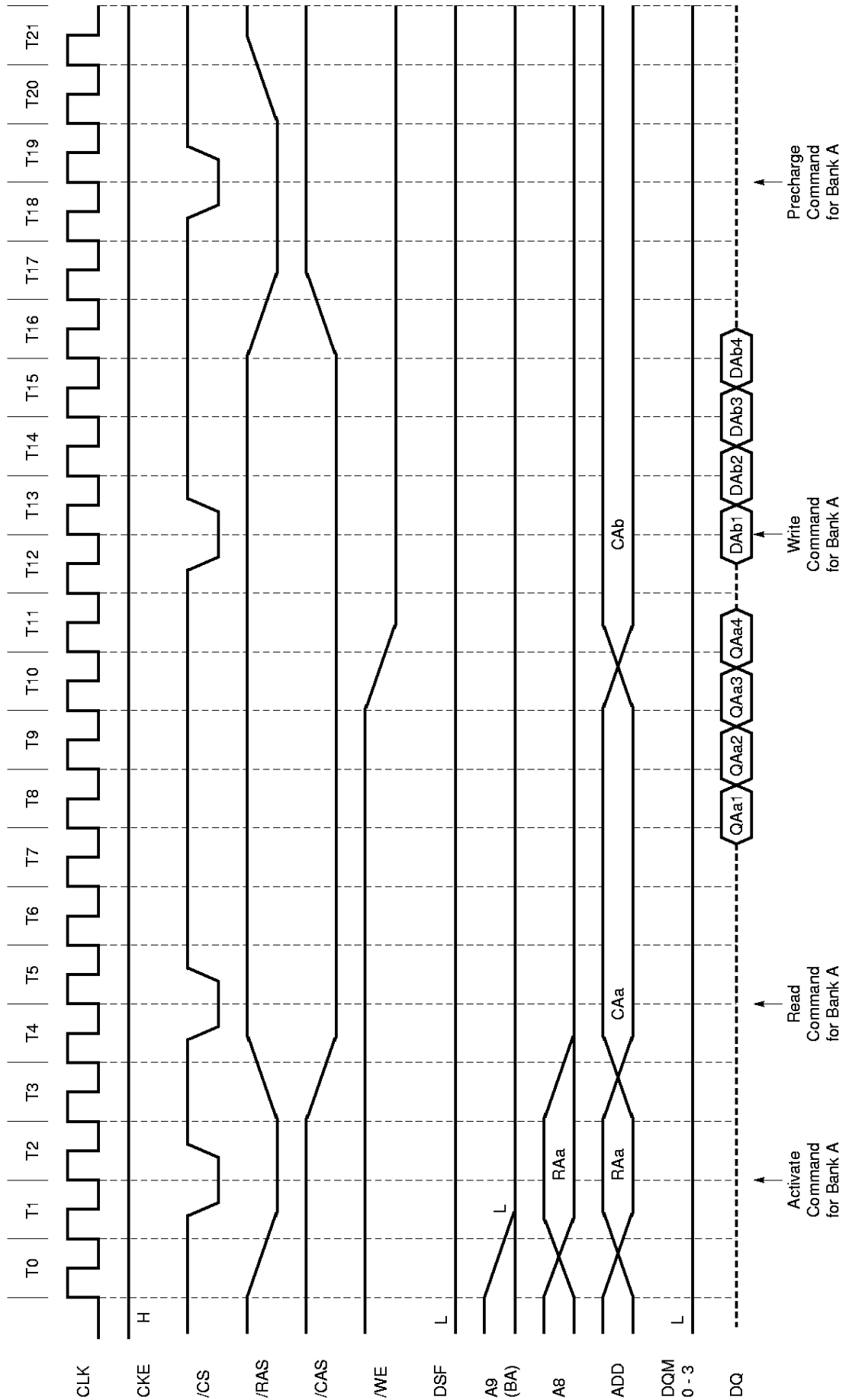

16.4 Basic Cycles  
16.4.1 Initialization

Power on Sequence and Auto Refresh

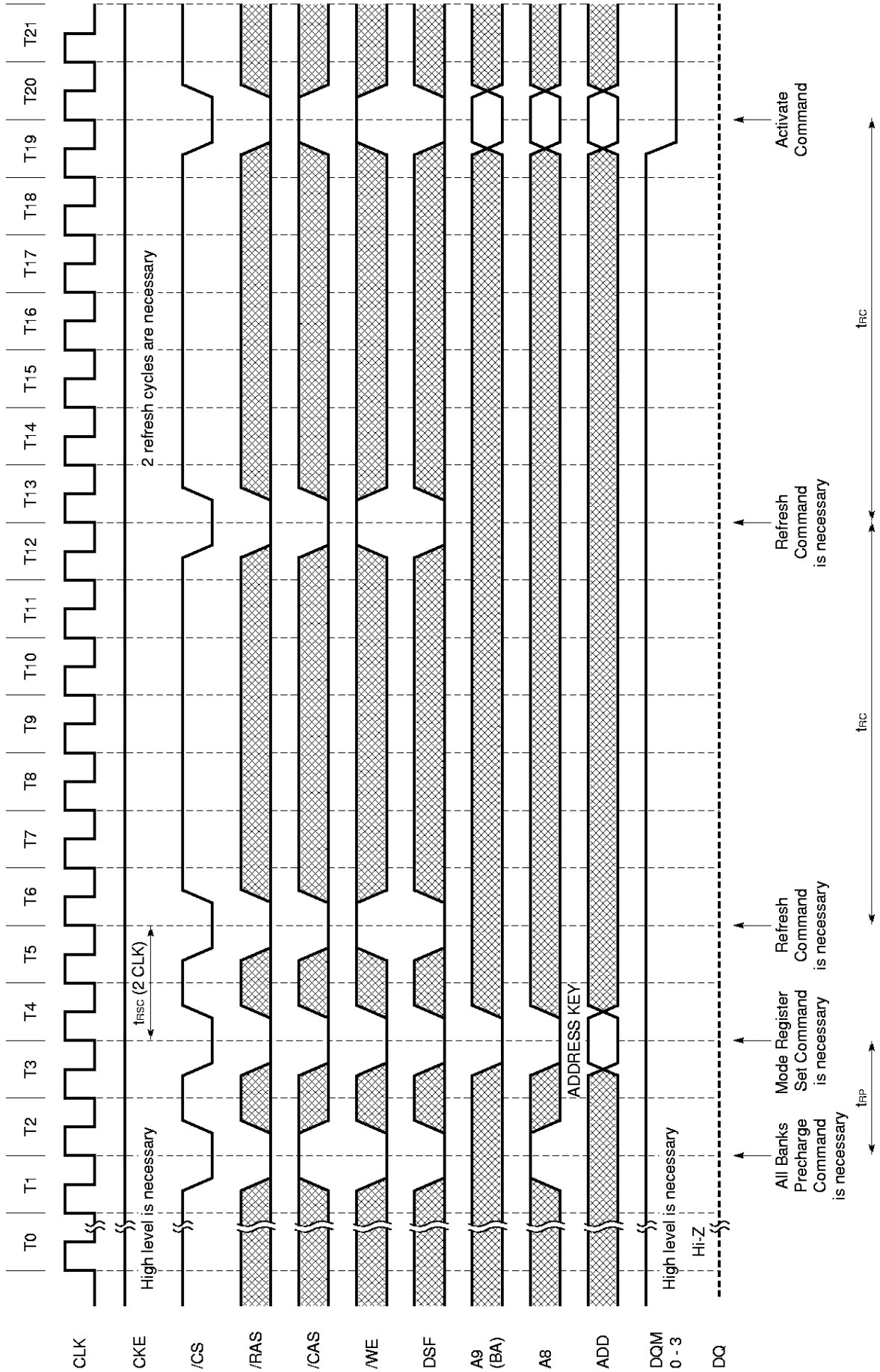

**16.4.2 Mode Register Set**  
**Mode Register** (Burst length = 4, /CAS latency = 2)

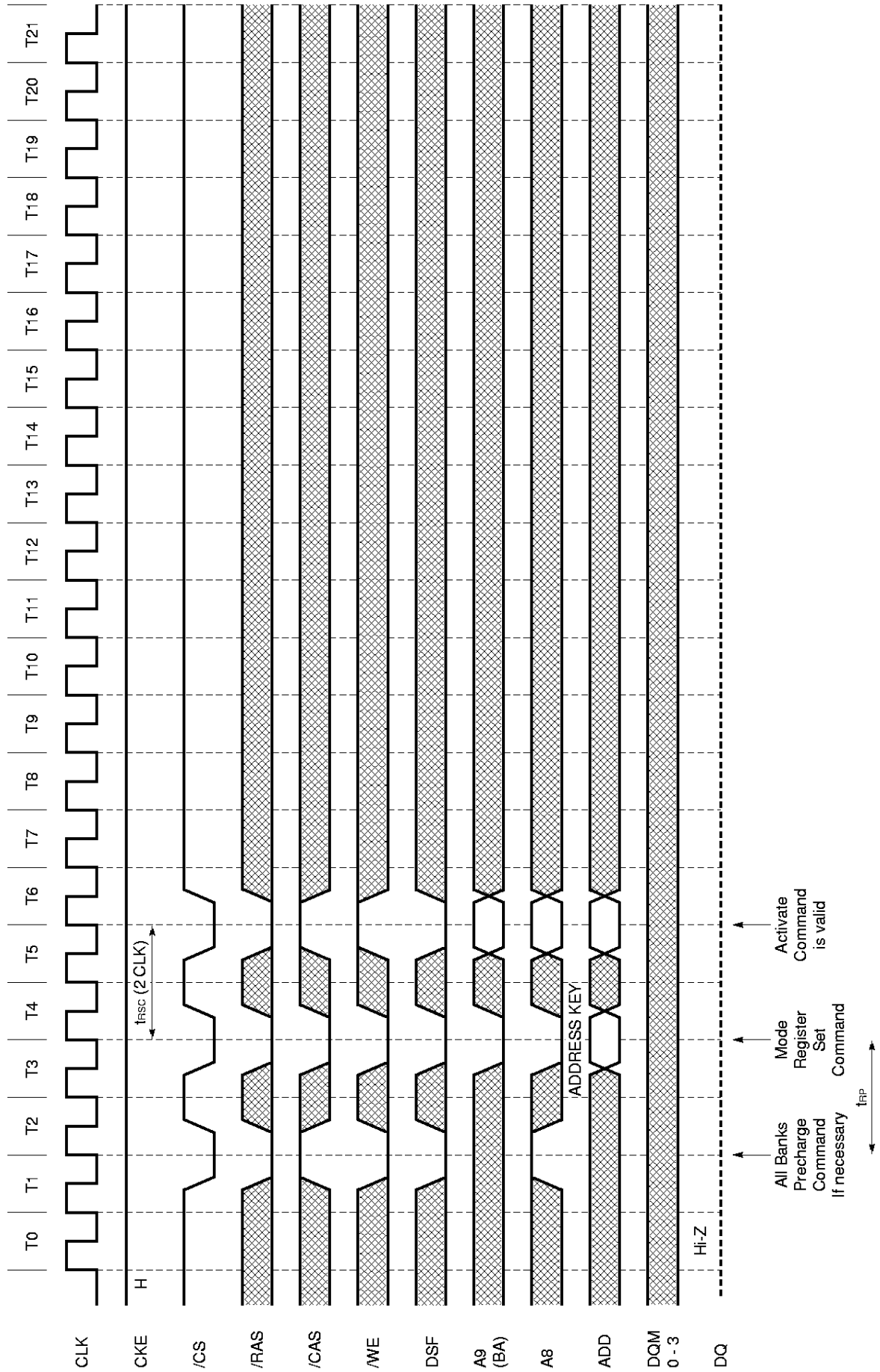

**16.4.3 Refresh Cycle**  
**CBR Refresh (/CAS latency = 2)**

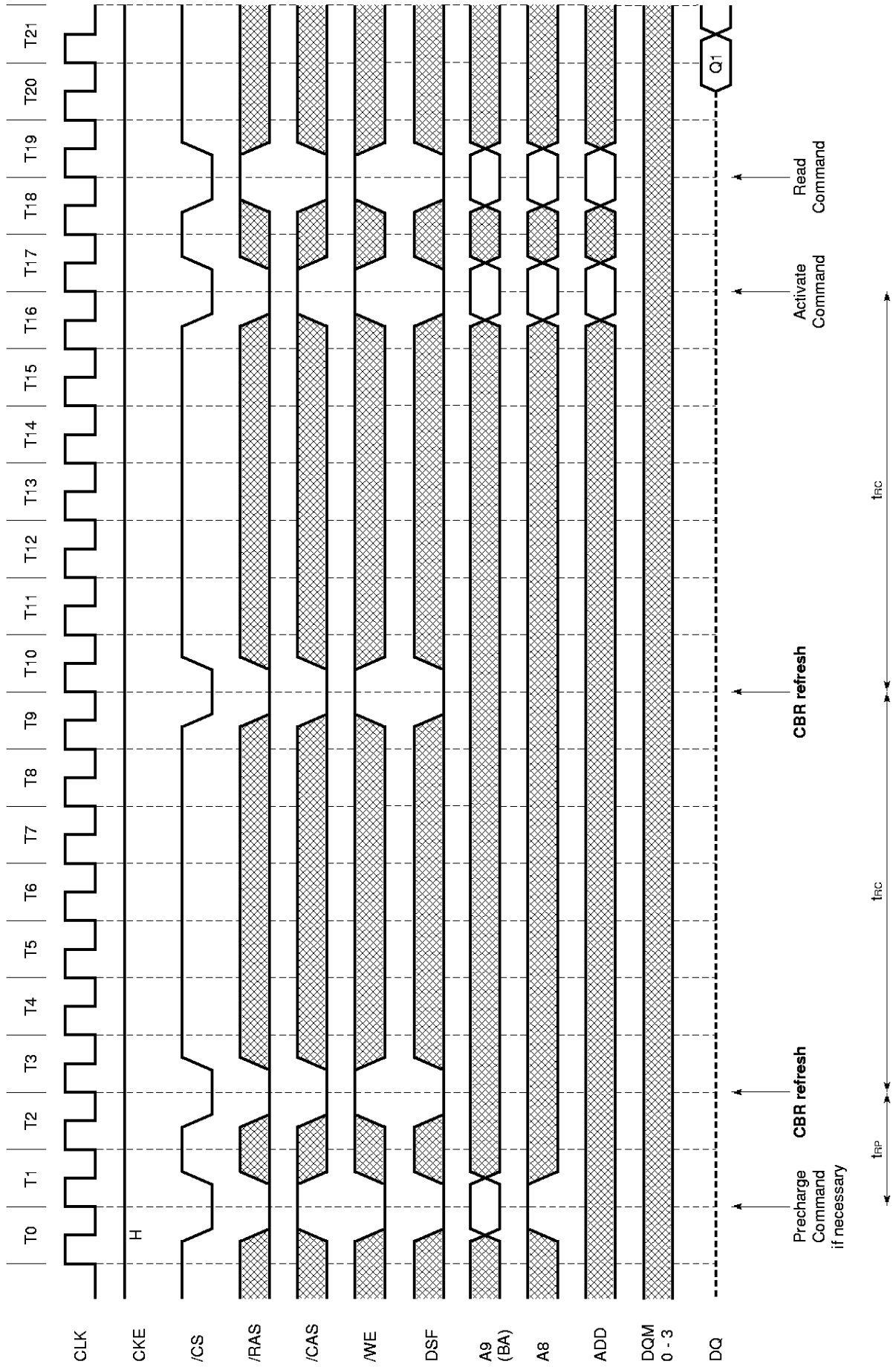

**Self Refresh (entry and exit)**

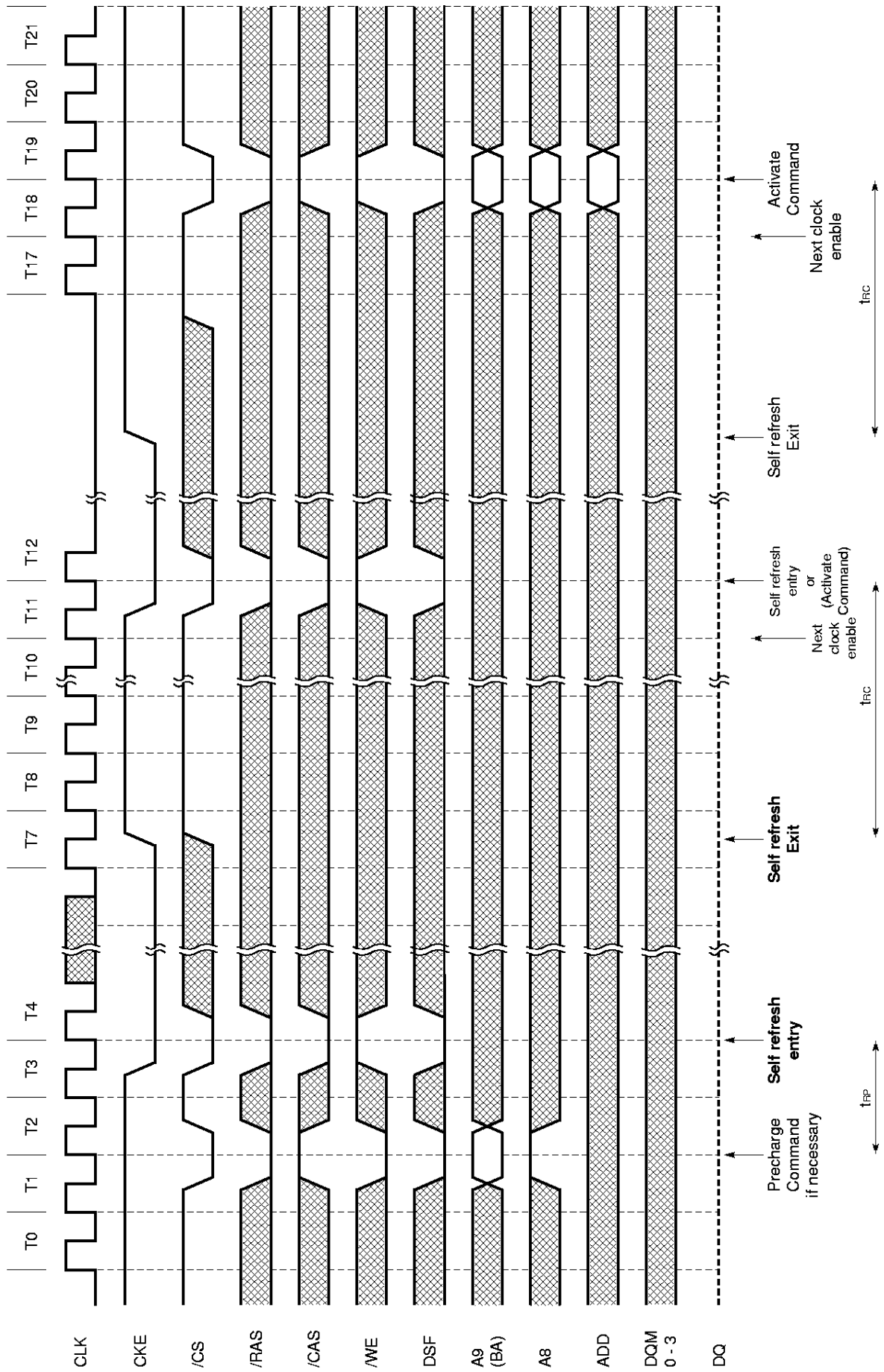



16.4.4 Cycle with Auto Precharge  
 Auto Precharge after Read Burst (1/2) (Burst length = 4, /CAS latency = 2)

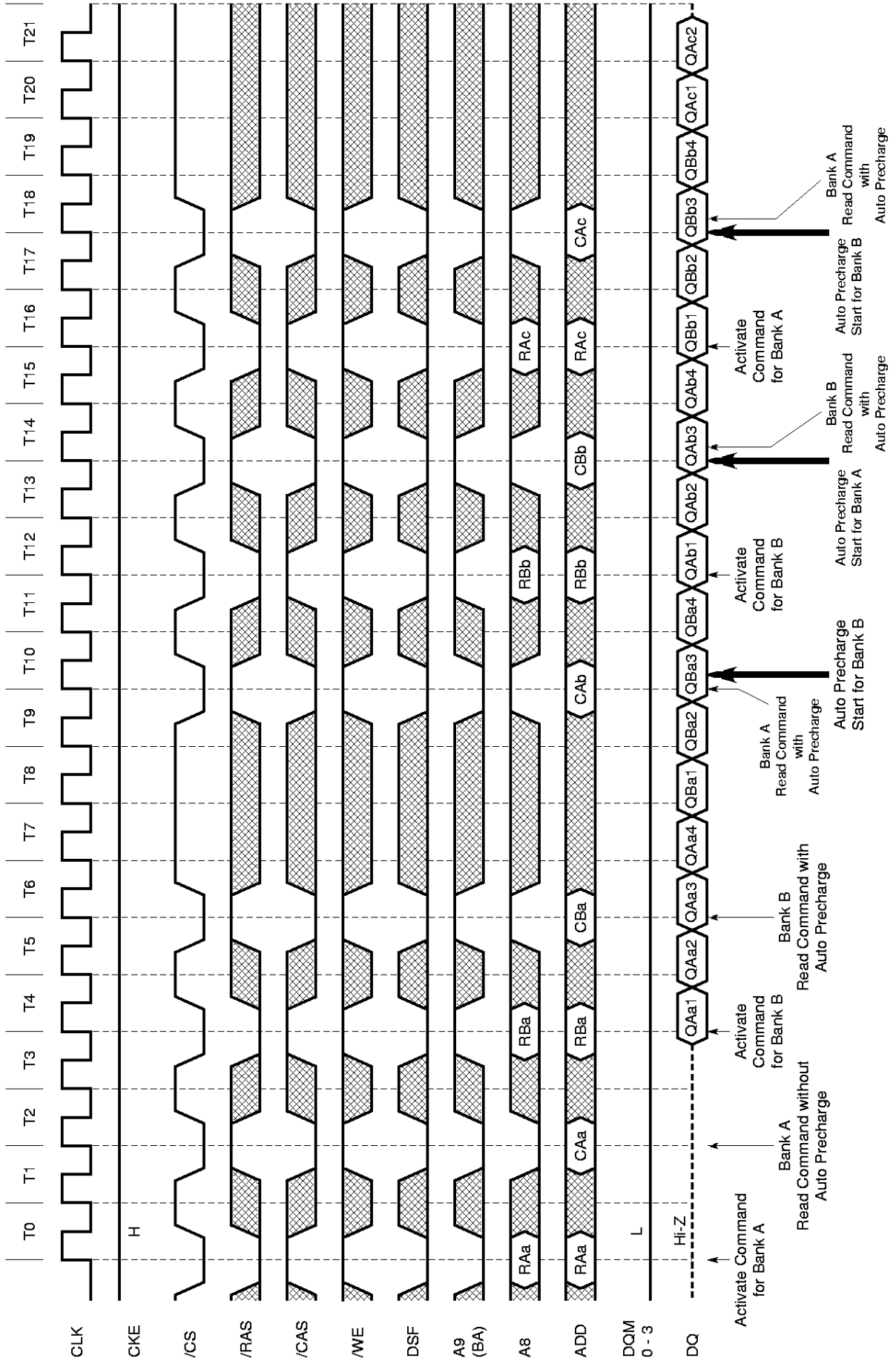

Auto Precharge after Read Burst (2/2) (Burst length = 4, /CAS latency = 3)

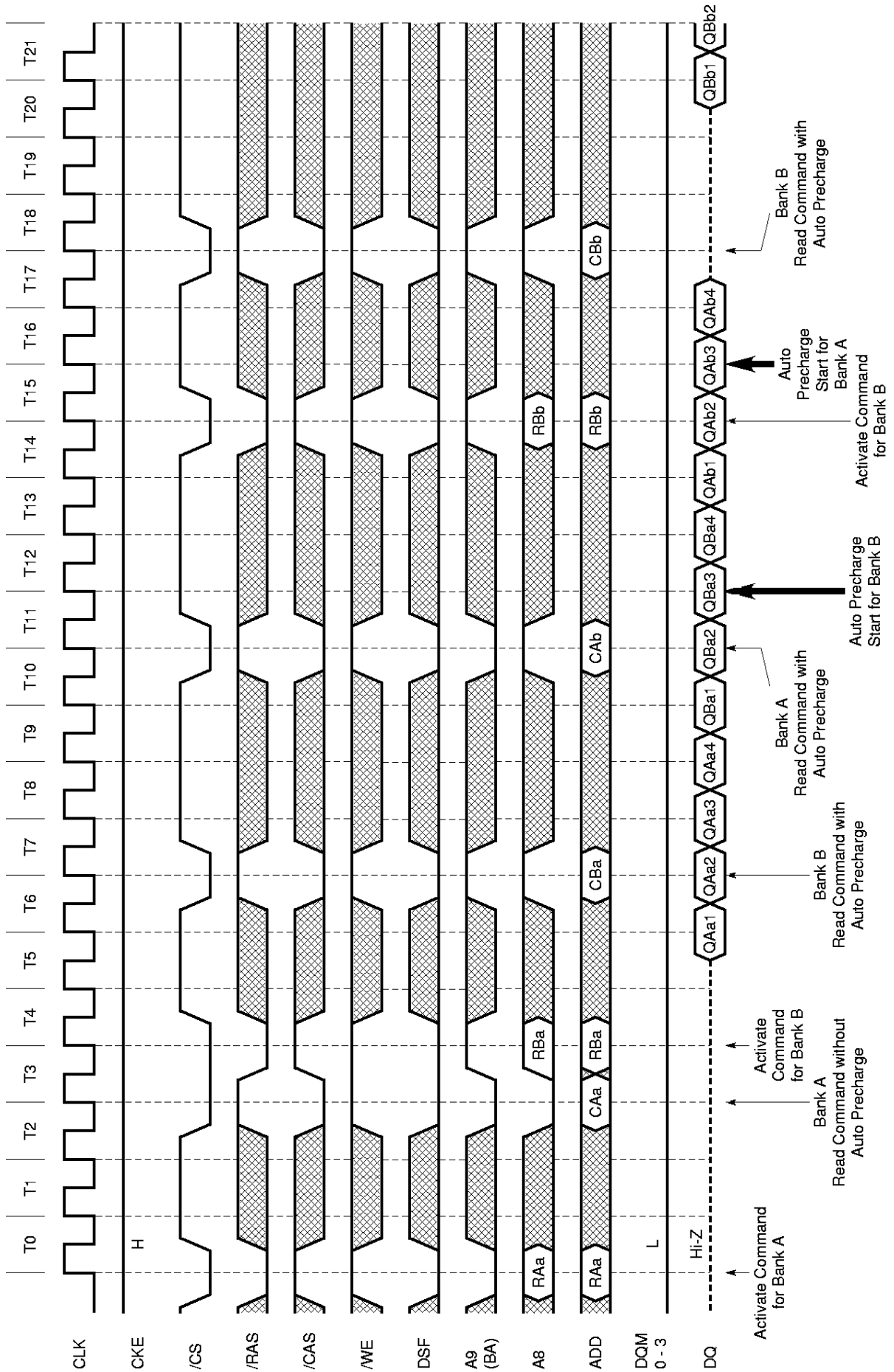

Auto Precharge after Write Burst (1/2) (Burst length = 4, /CAS latency = 2)

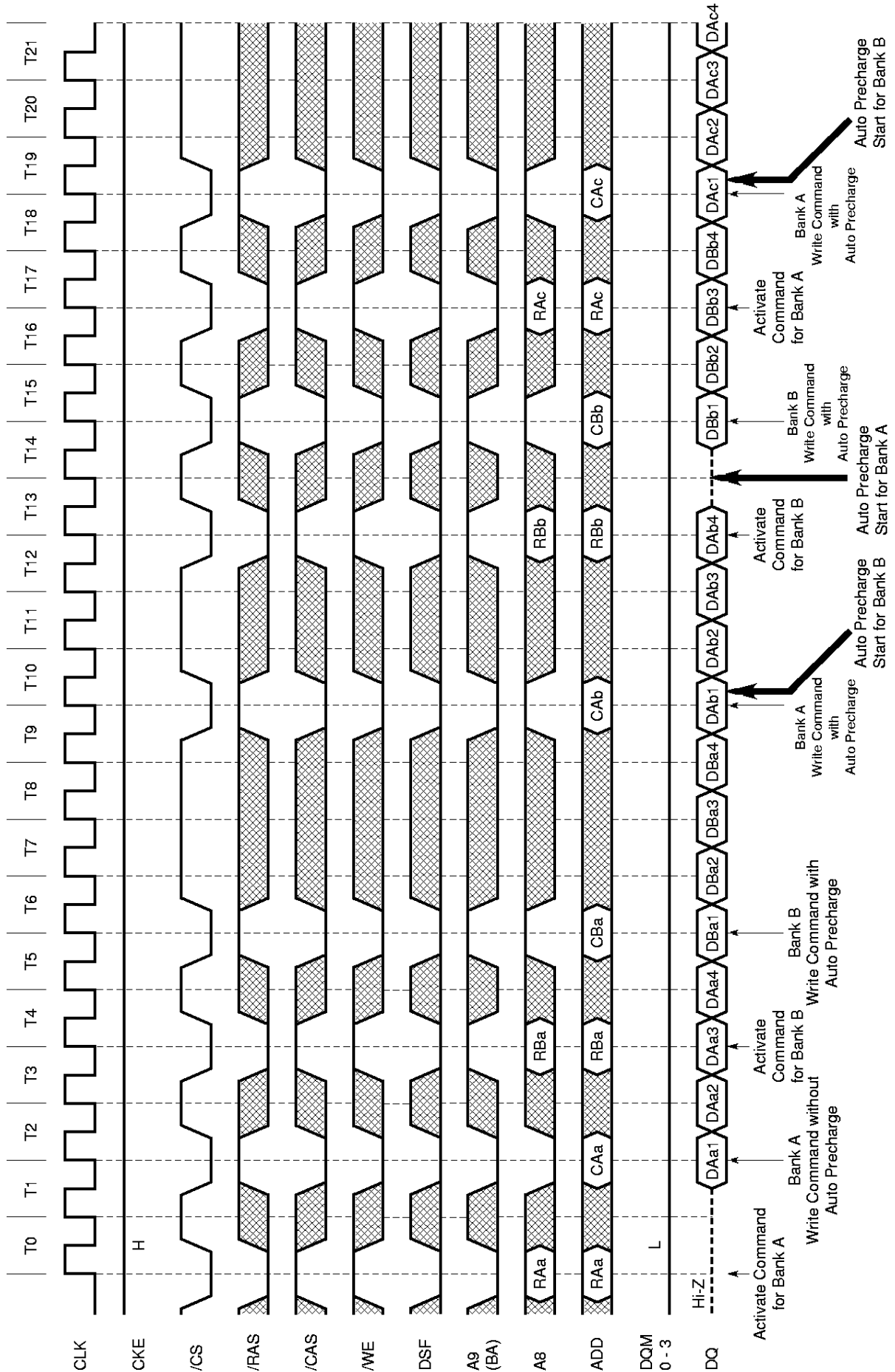

Auto Precharge after Write Burst (2/2) (Burst length = 4, /CAS latency = 3)

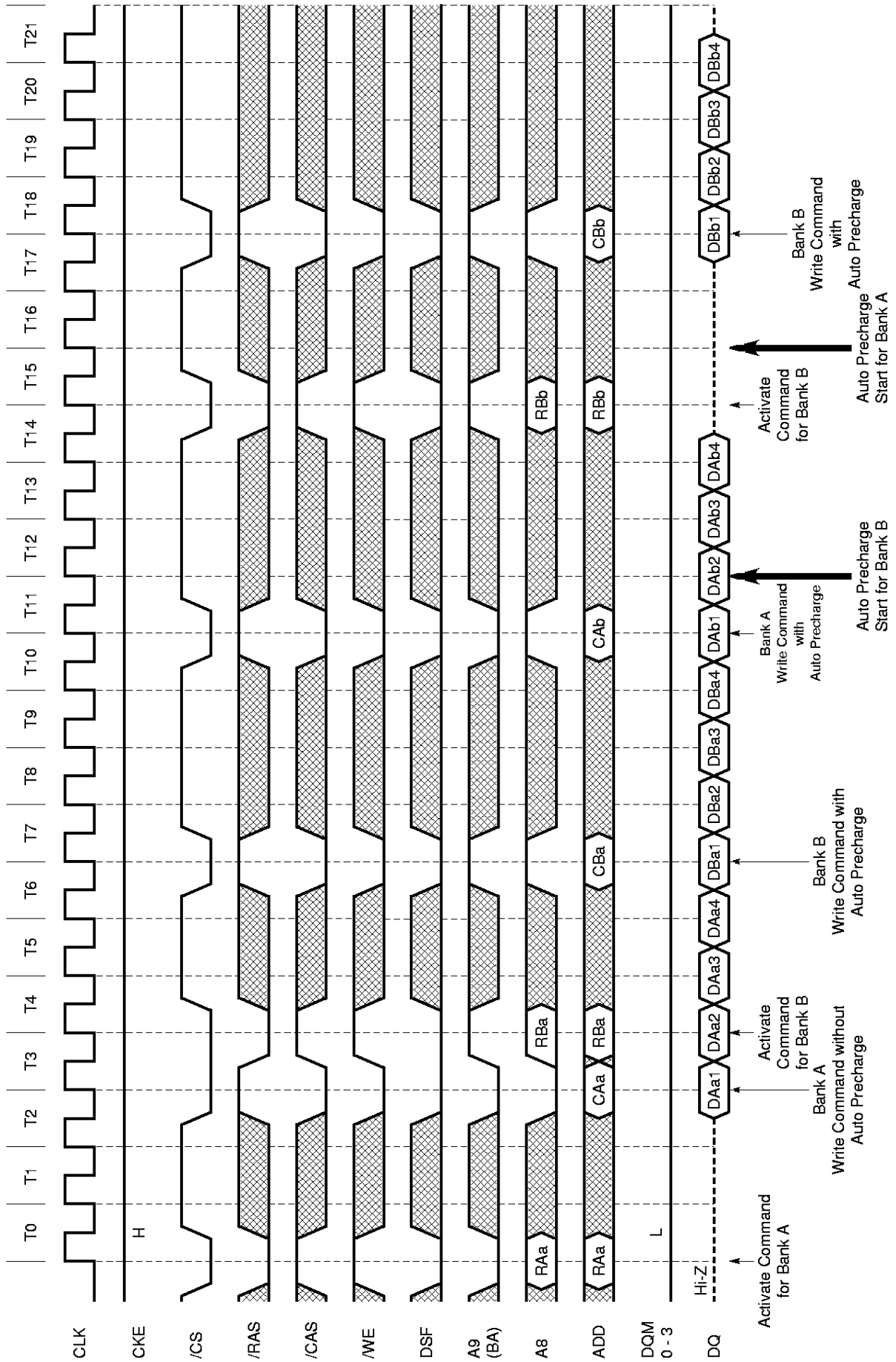

16.4.5 Full Page Mode Cycle  
Full Page READ Cycle (1/2) (/CAS latency = 2)

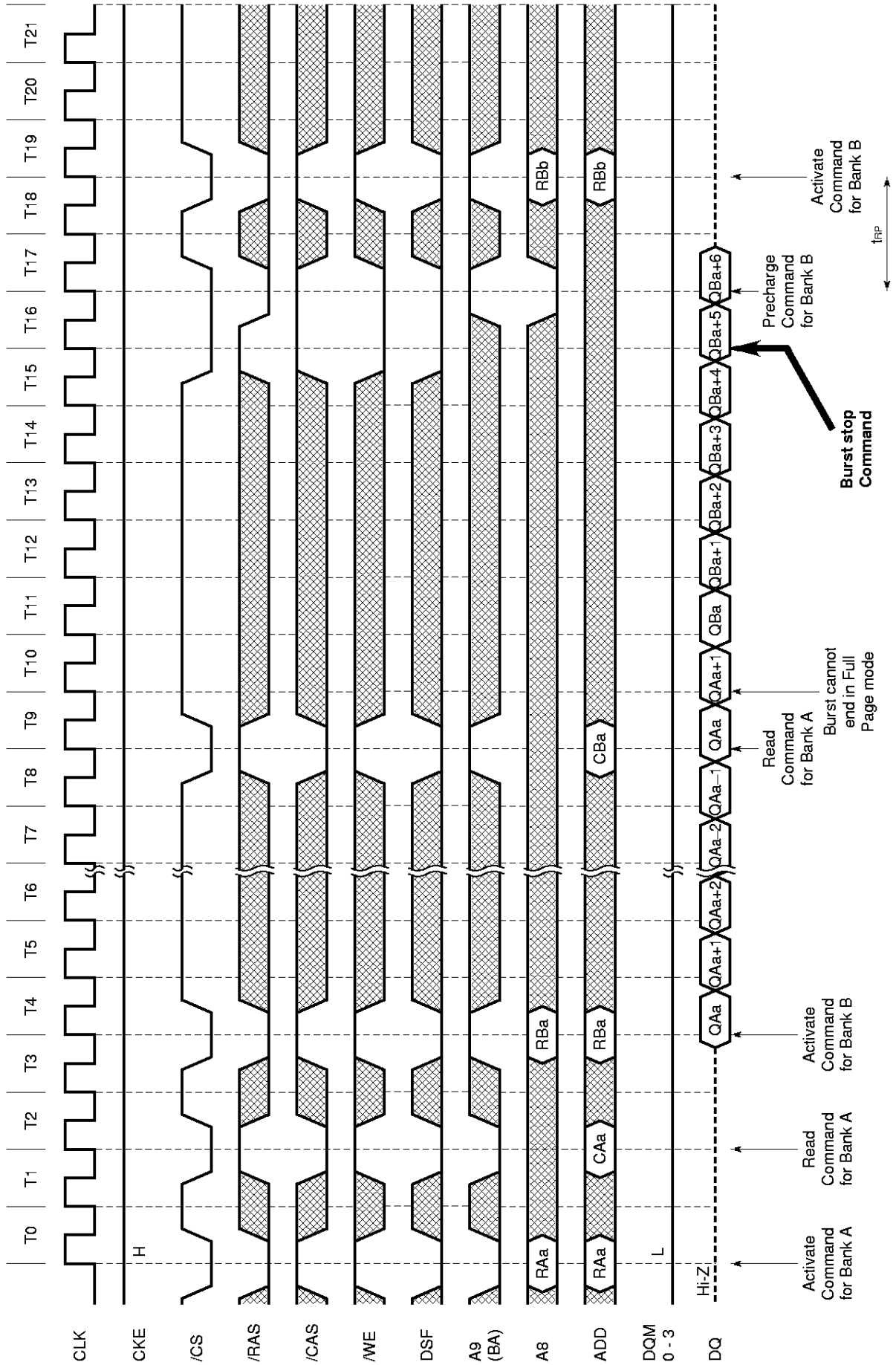

Full Page READ Cycle (2/2) (/CAS latency = 3)

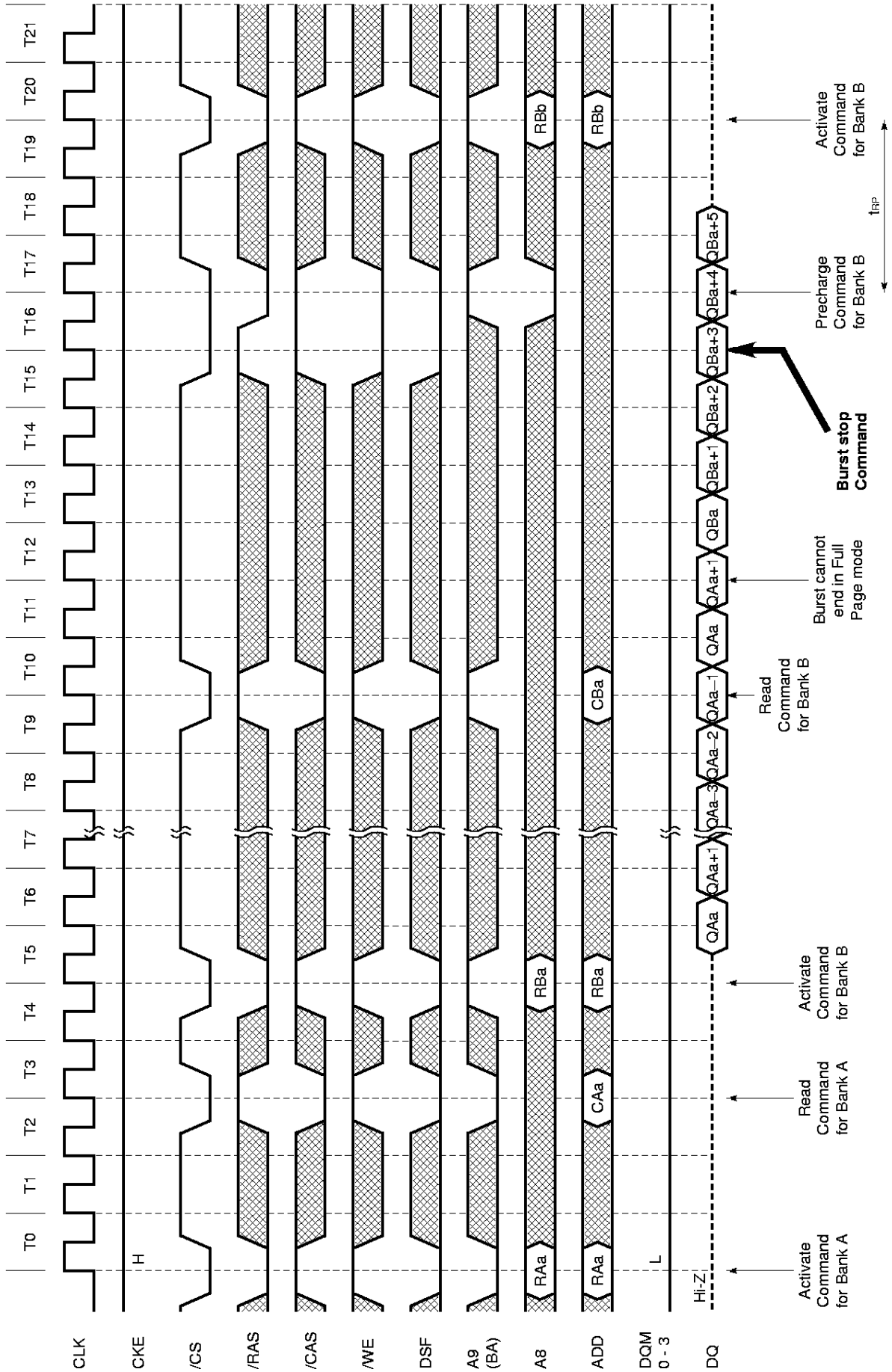

Full Page WRITE Cycle (1/2) (/CAS latency = 2)

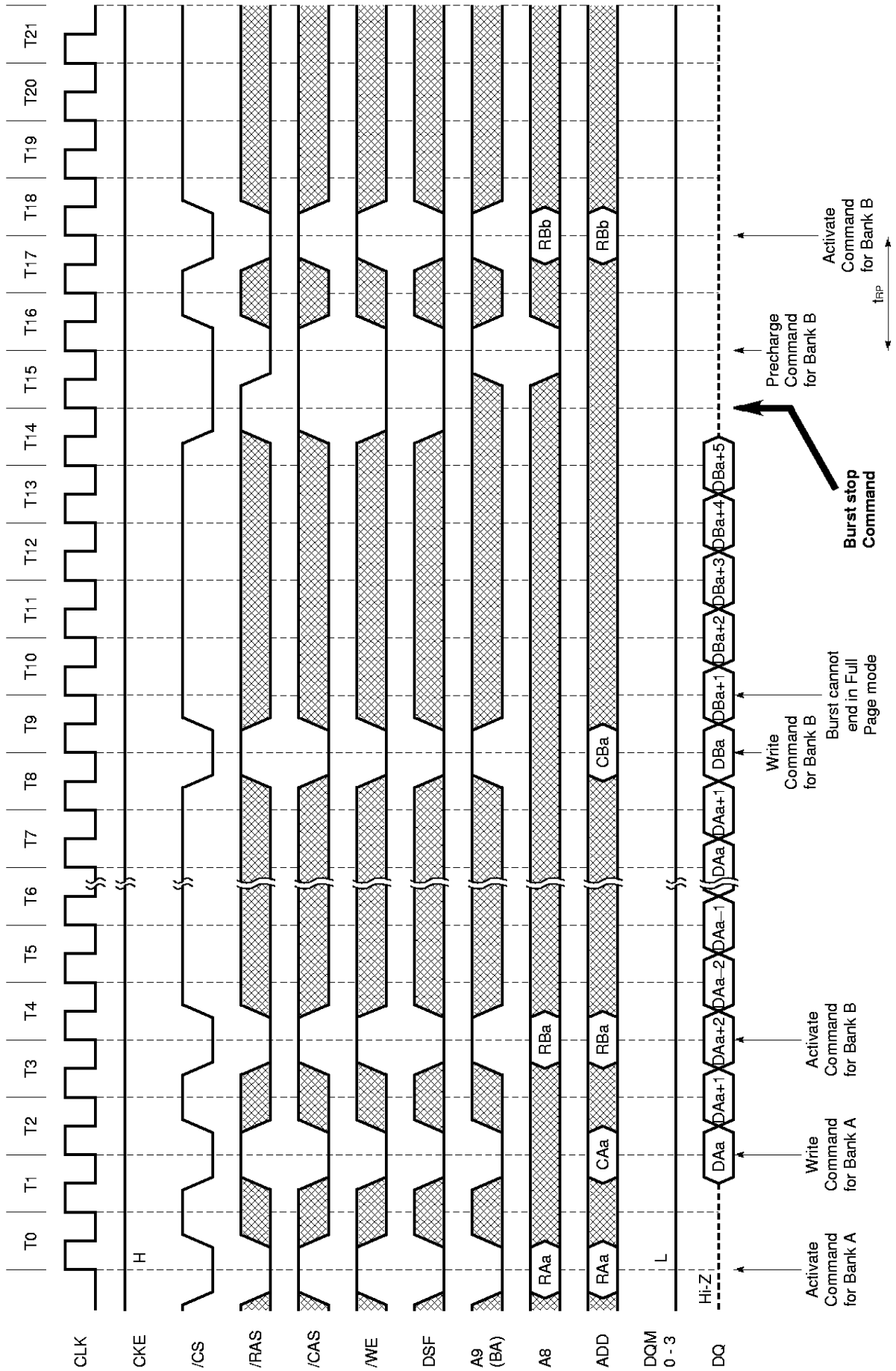

Full Page WRITE Cycle (2/2) (/CAS latency = 3)

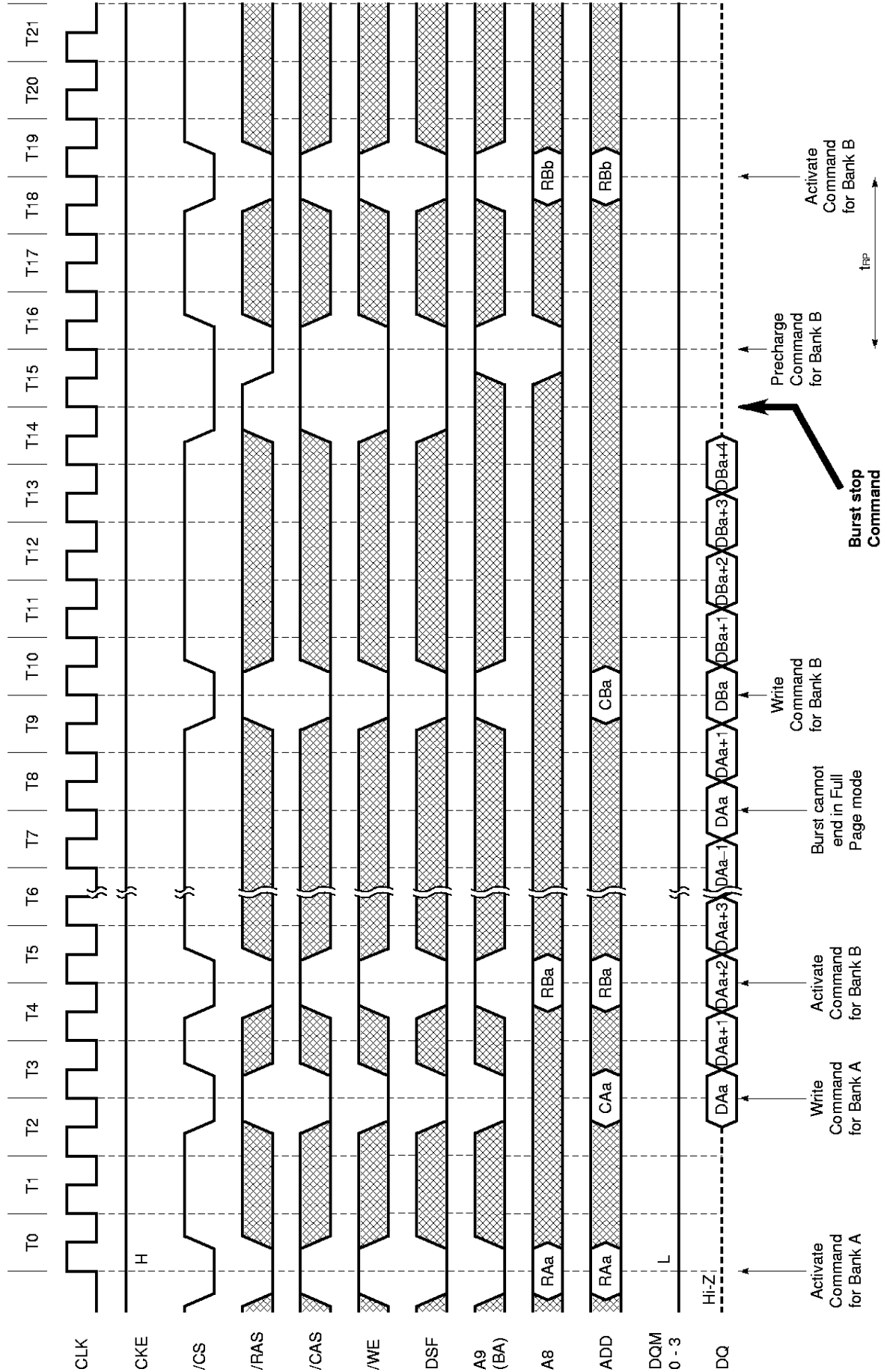



16.4.6 Precharge Termination Cycle

PRE (Precharge) Termination of Burst (1/2) (Burst length = 2, 4, 8, Full, /CAS latency = 2)

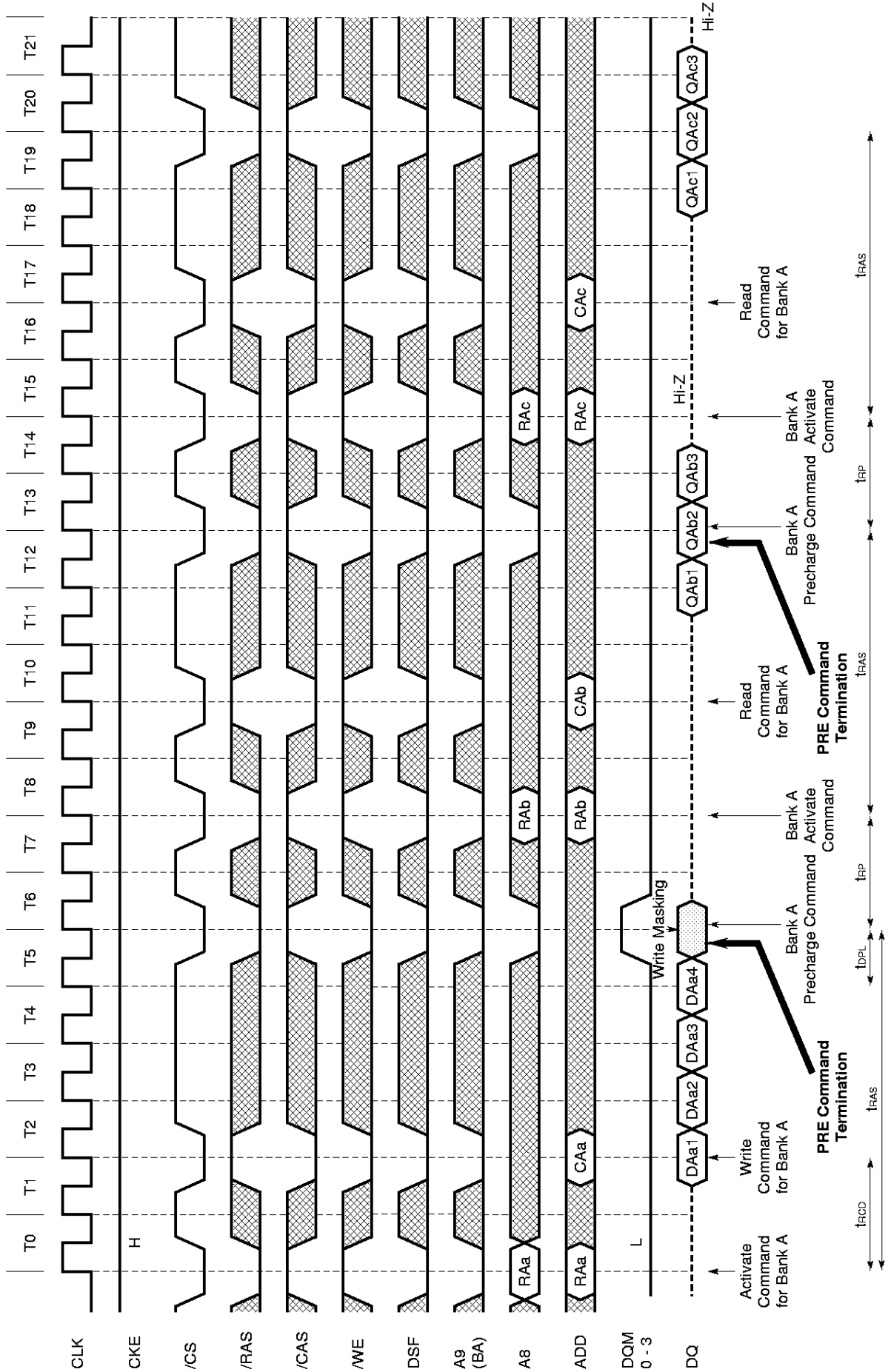

**PRE (Precharge) Termination of Burst (2/2)** (Burst length = 2, 4, 8, Full, /CAS latency = 3)

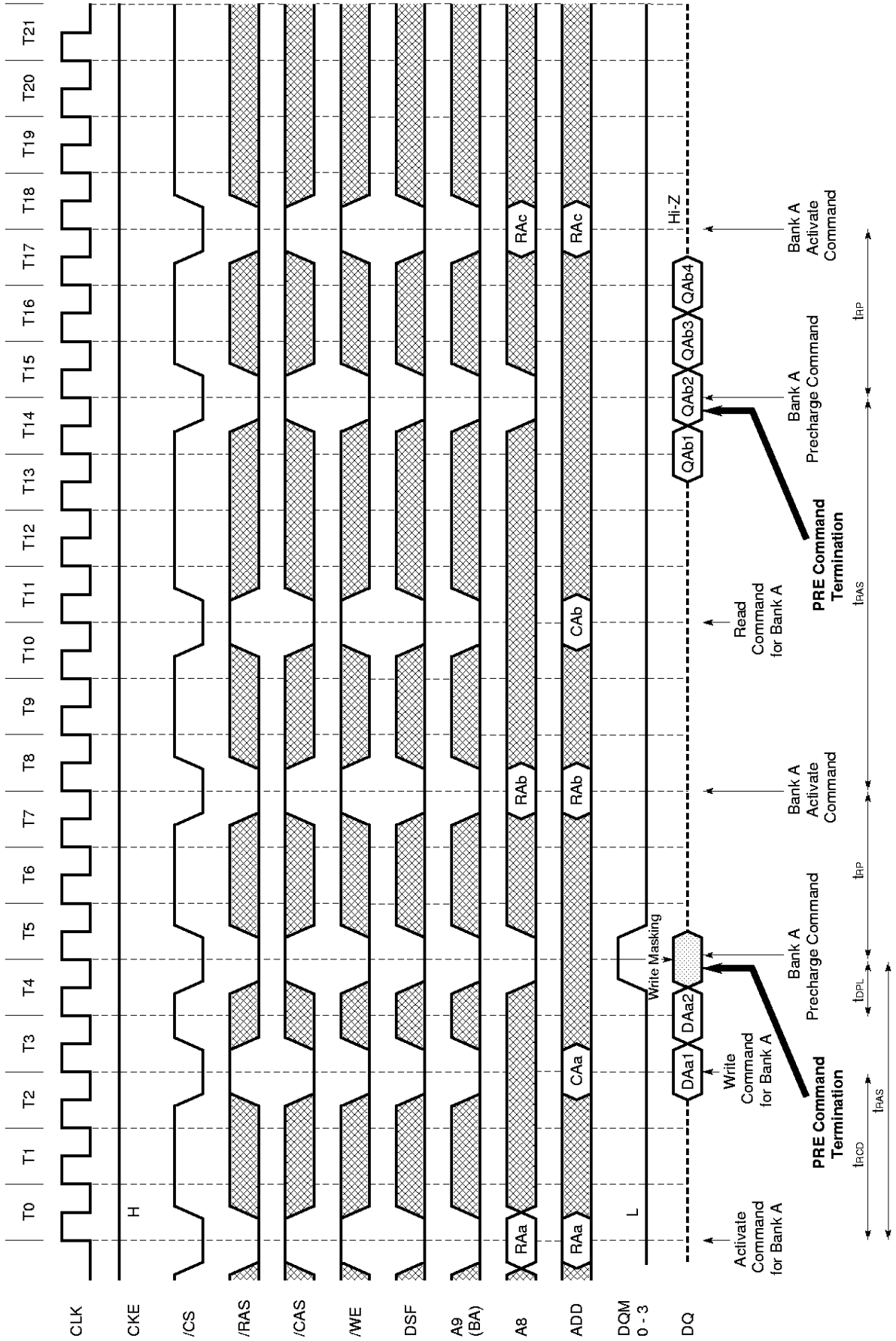

**16.4.7 Clock Suspension**  
**Clock Suspension during Burst Read (using CKE Function) (1/2) (Burst length = 4, /CAS latency = 2)**

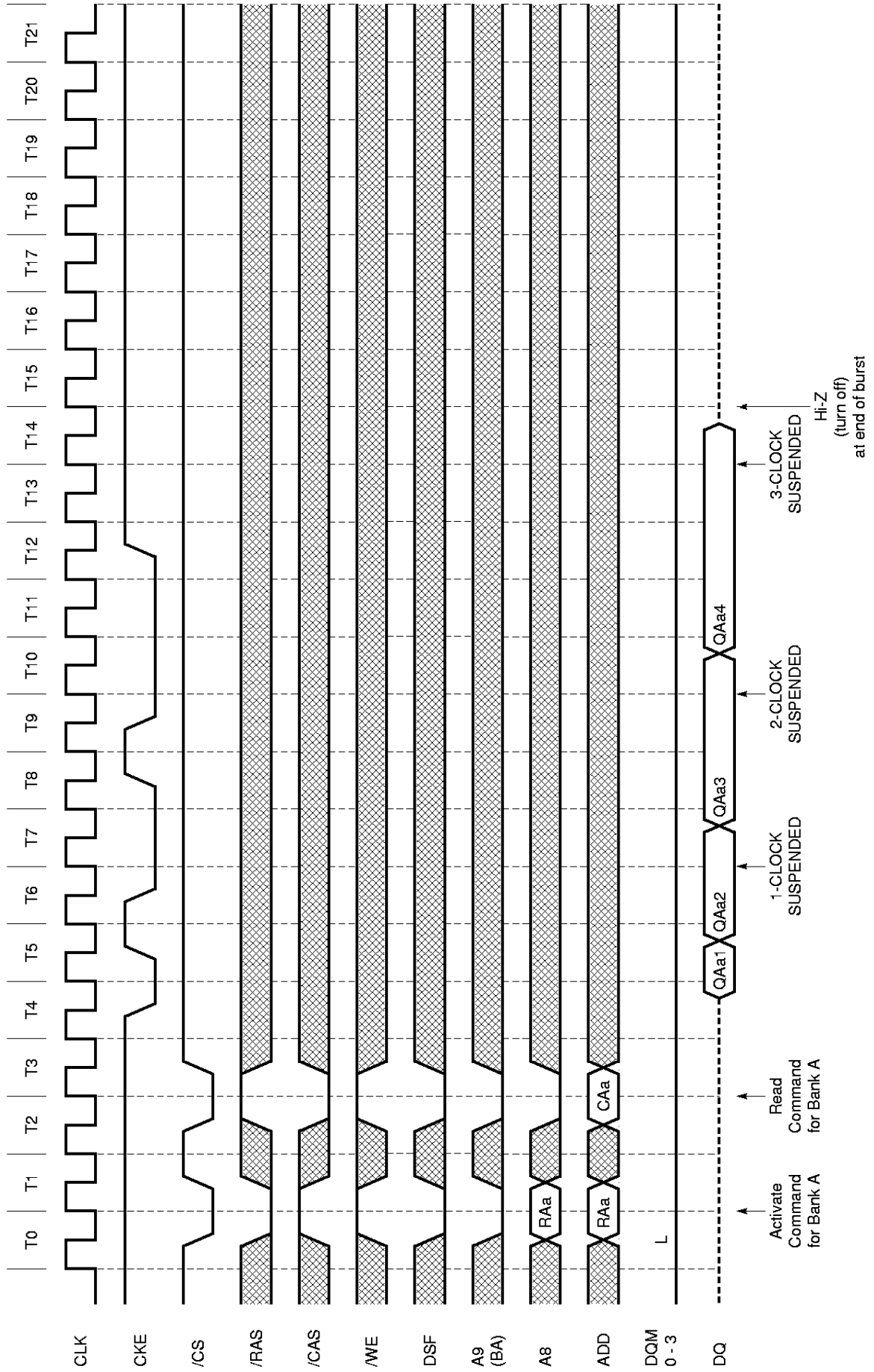

**Clock Suspension during Burst Read (using CKE Function) (2/2)** (Burst length = 4, /CAS latency = 3)

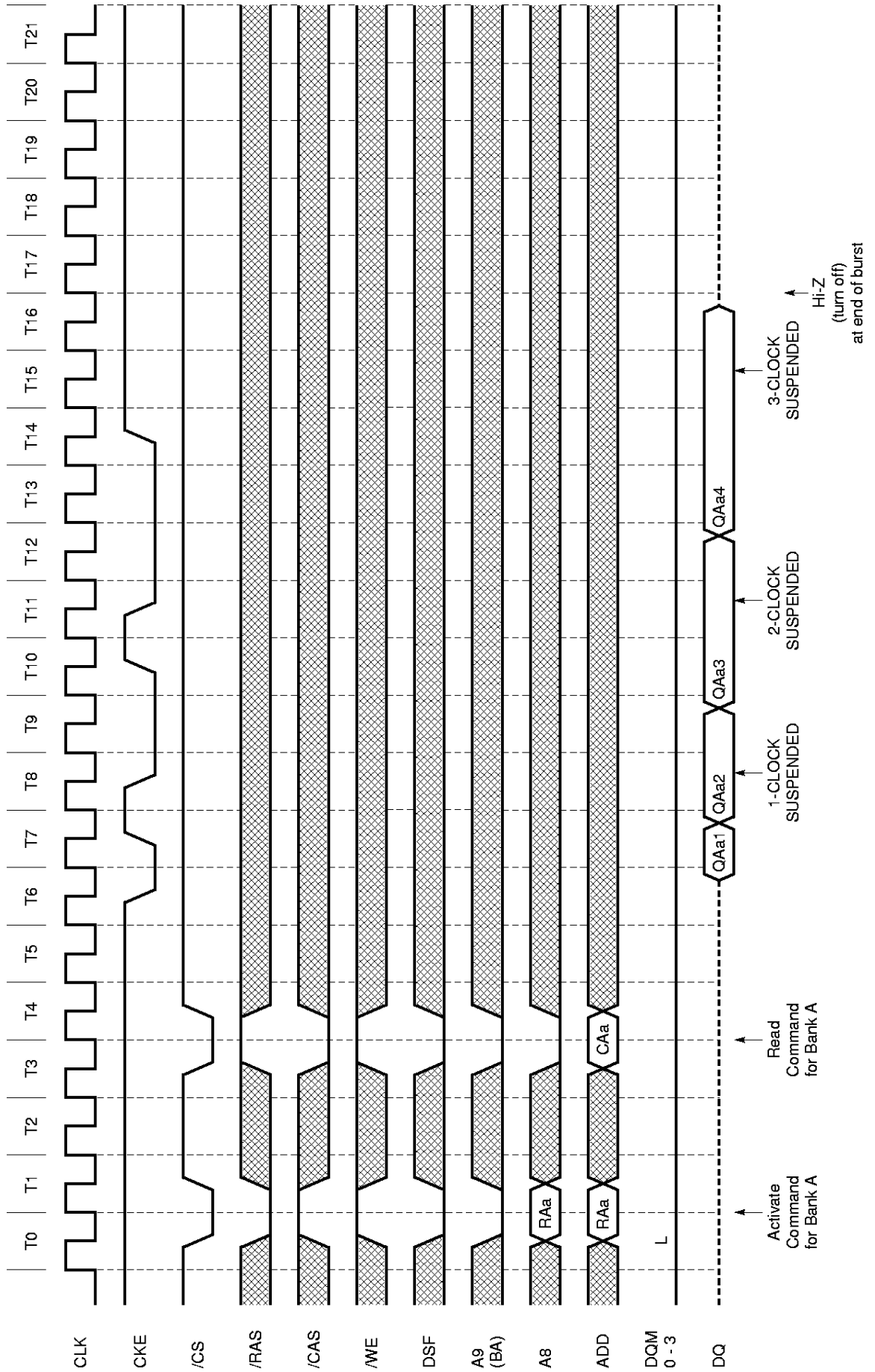

**Clock Suspension during Burst Write (using CKE Function) (1/2) (Burst length = 4, /CAS latency = 2)**

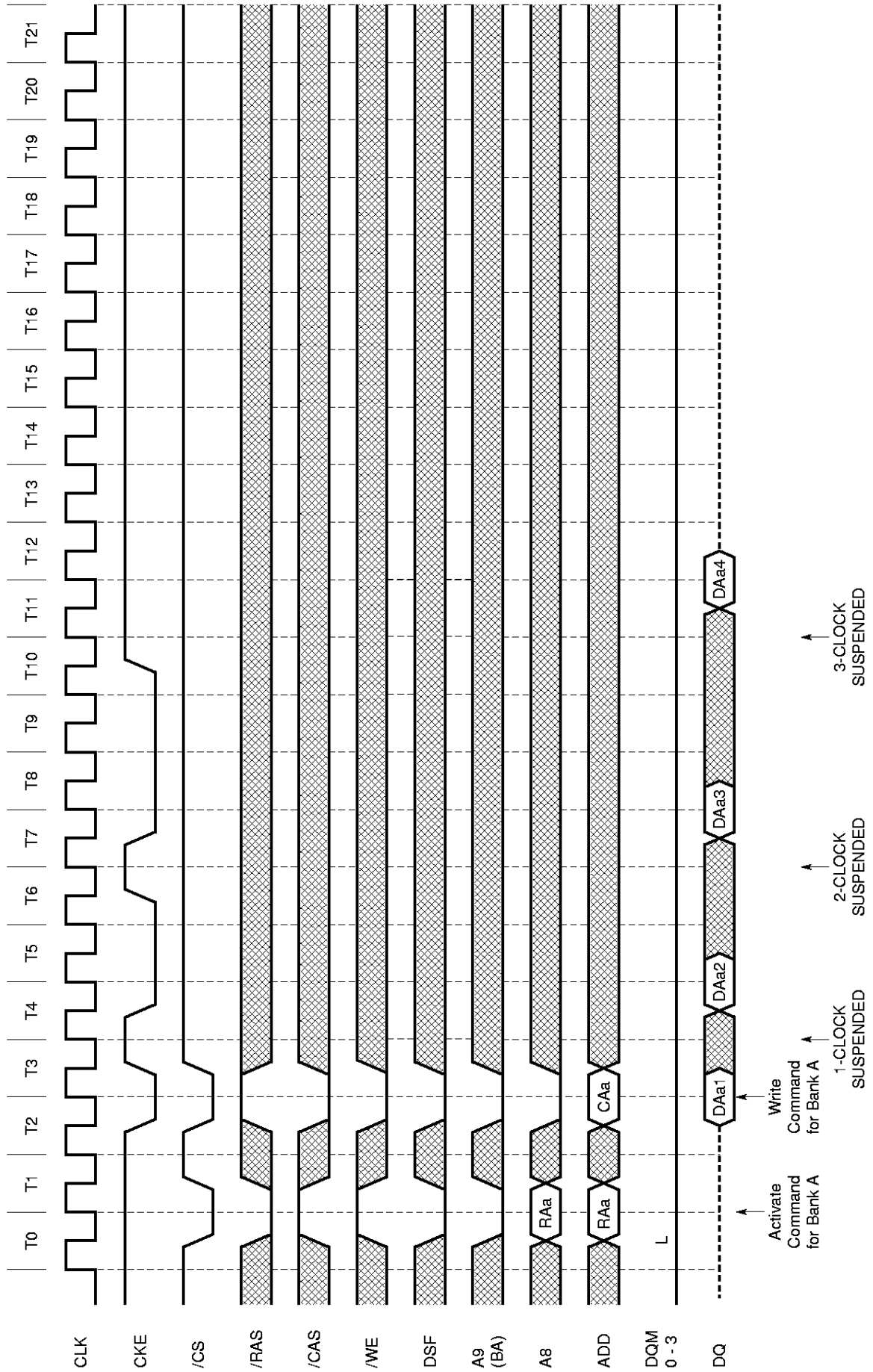

**Clock Suspension during Burst Write (using CKE Function) (2/2) (Burst length = 4, /CAS latency = 3)**

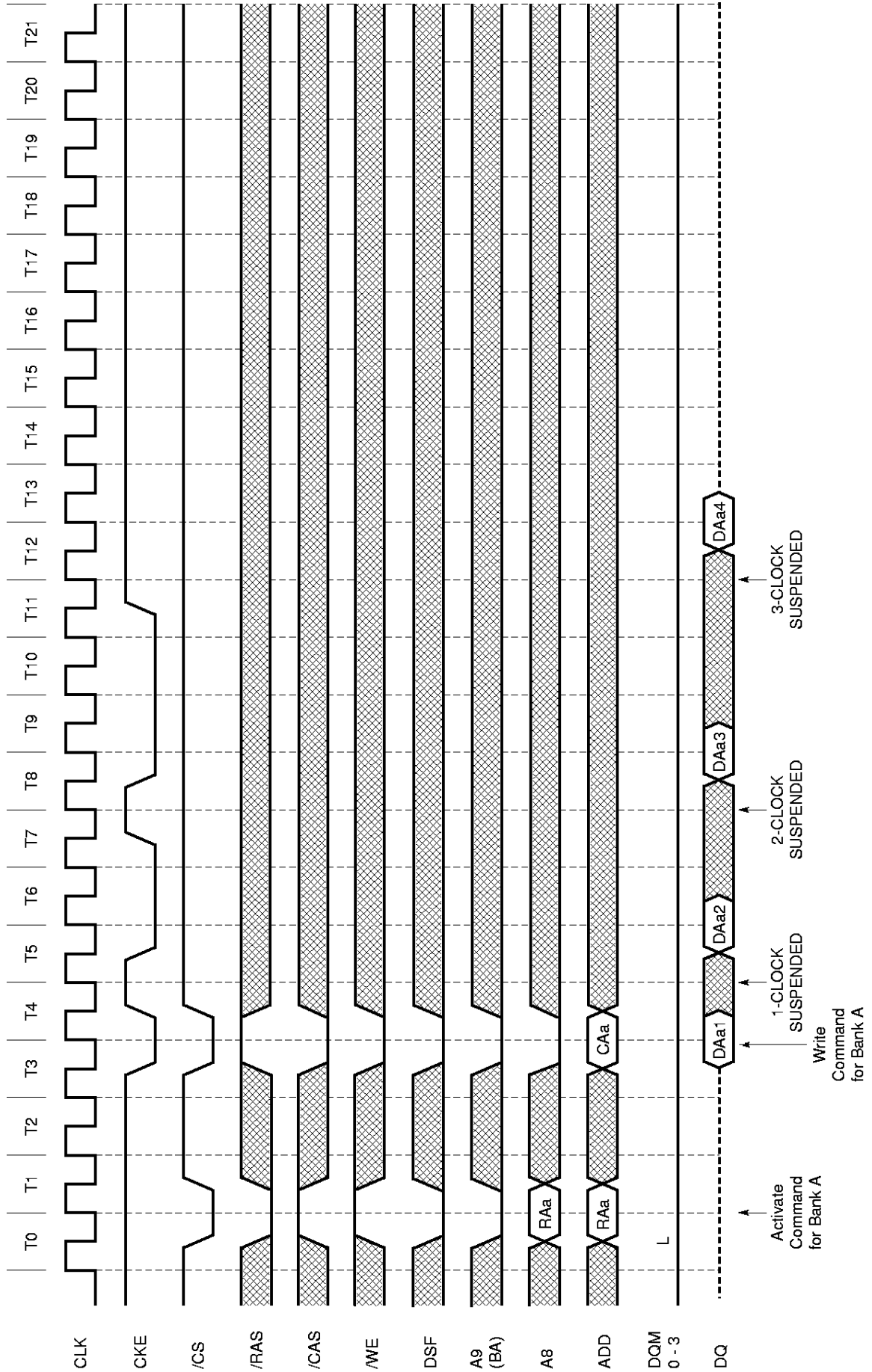

16.4.8 Power Down Mode

Power Down Mode and Clock Suspension (Burst length = 4, /CAS latency = 2)

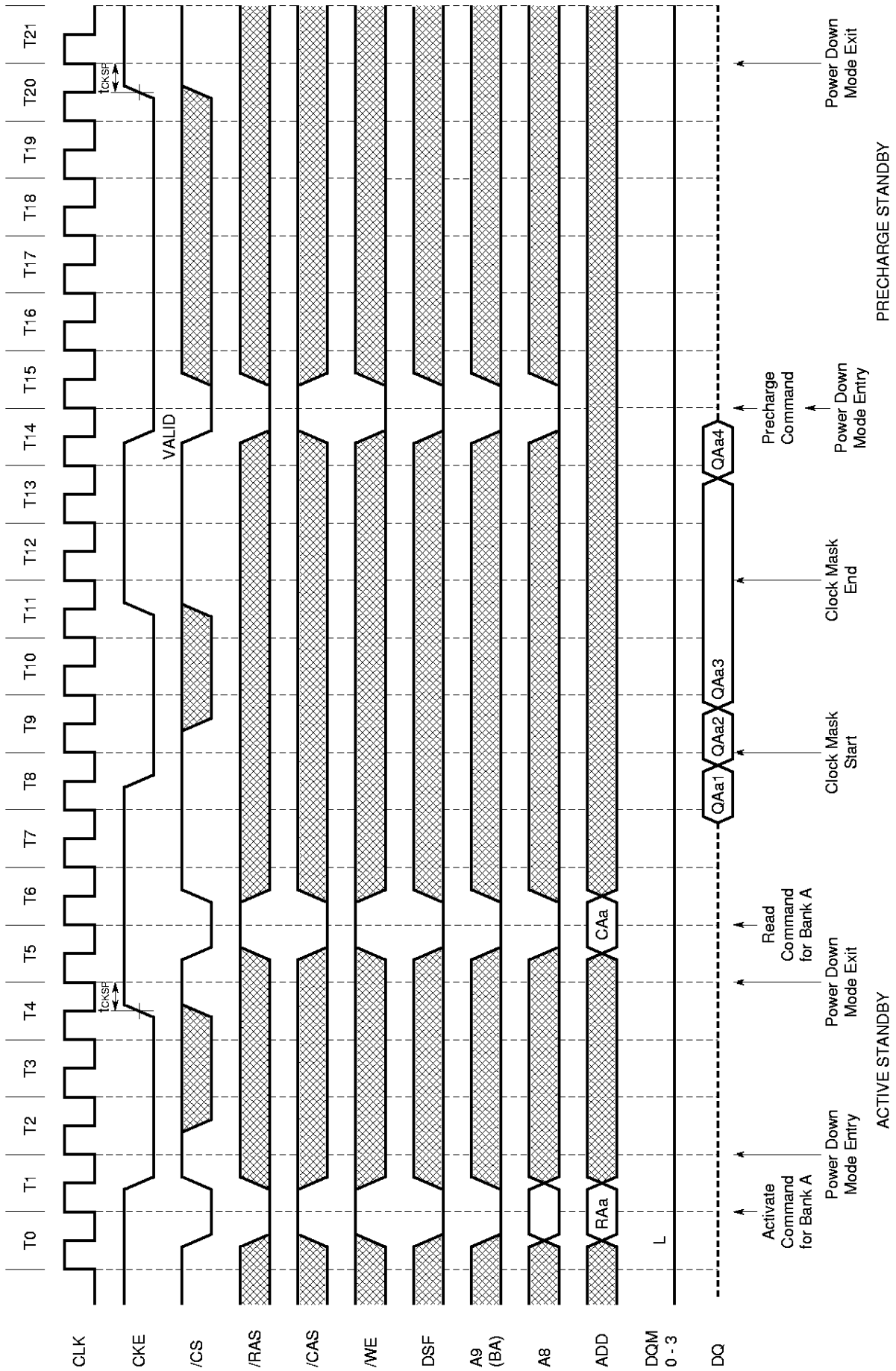

16.4.9 Other Cycles

Byte Read/Write Operation (By DQM) (Burst length = 4, /CAS latency = 2)

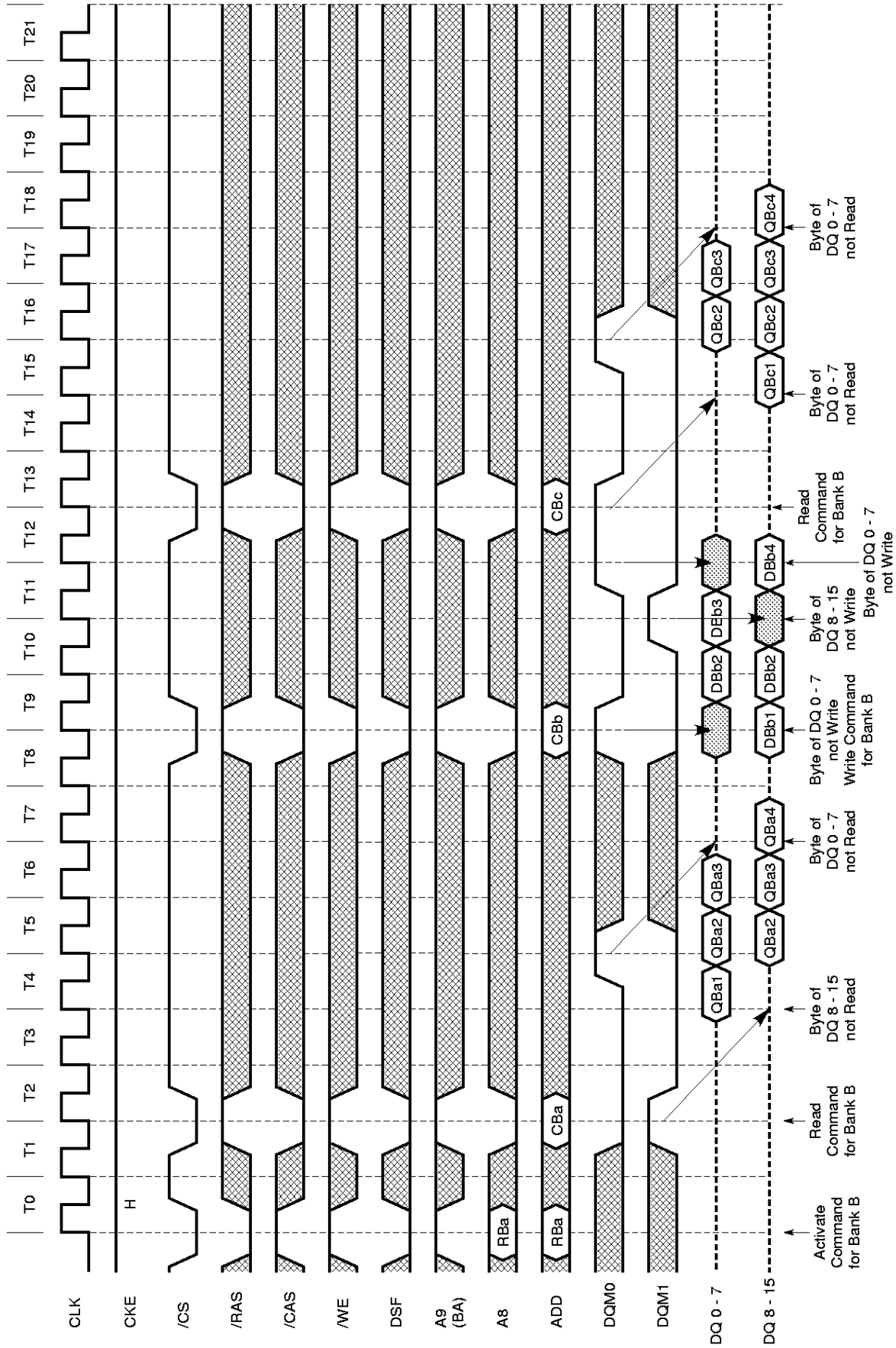

Remark The timings of DQM2, DQM3, and the corresponding DQ16 - 23, DQ24 - 31 are omitted.



Burst Read and Single Write (Burst length = 4, /CAS latency = 2)

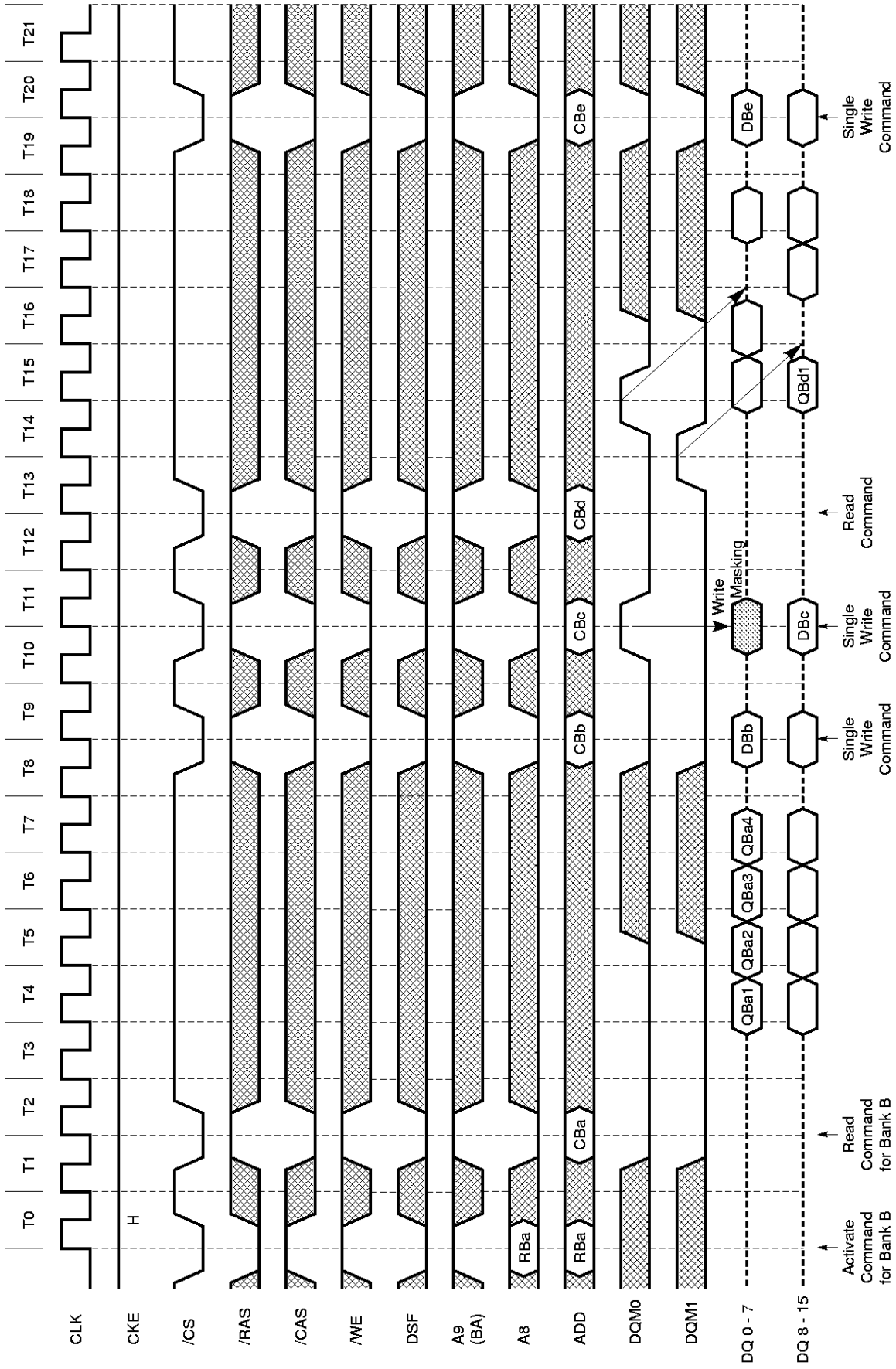

Remark The timings of DQM2, DQM3, and the corresponding DQ16 - 23, DQ24 - 31 are omitted.

16.5 Graphics Cycles

Special Register Set (Burst length = 4, /CAS latency = 2)

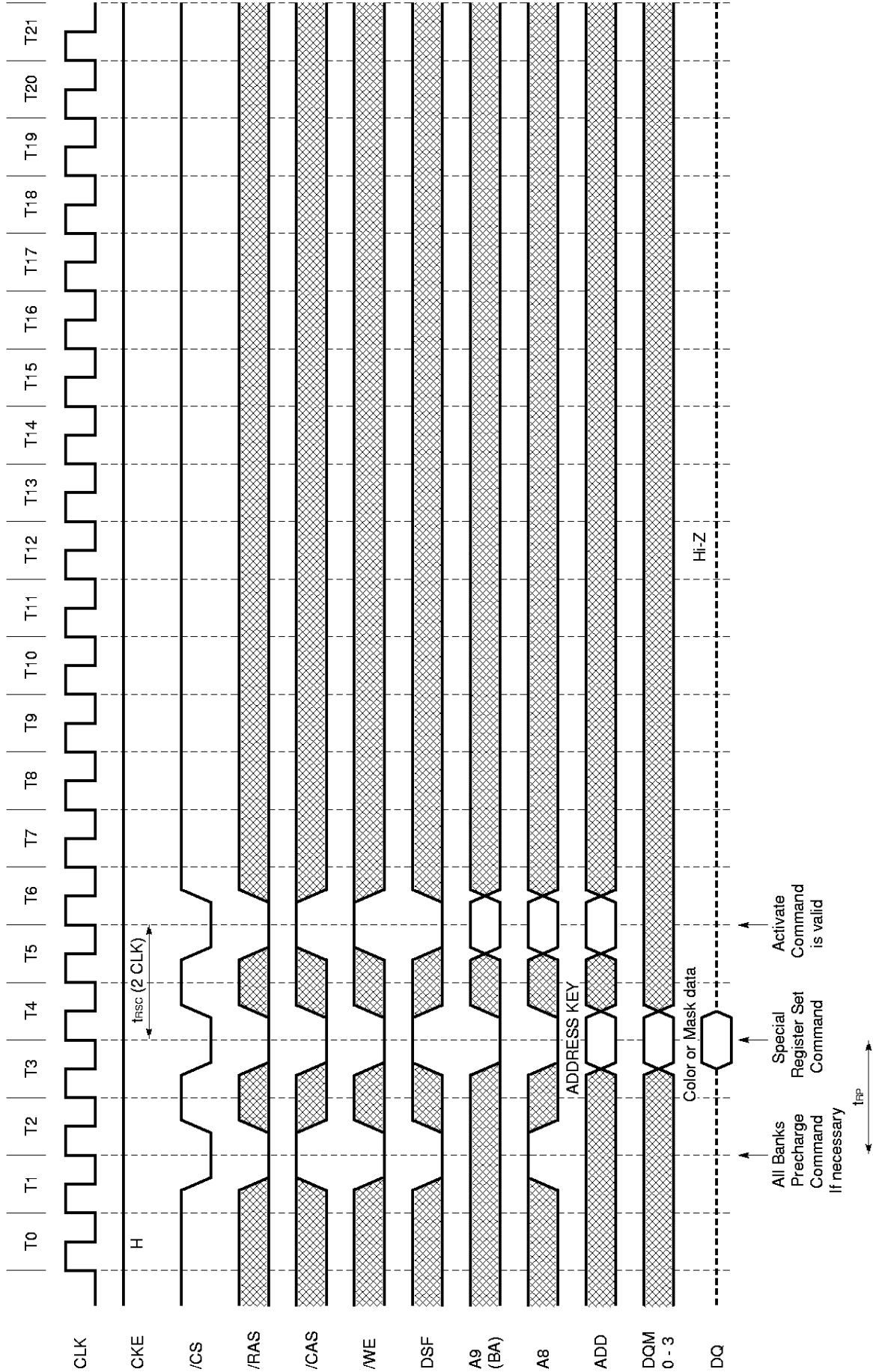

Remark Special Register Set command is able to input at idle state or row active state.

Random Row Write with WPB (Ping-pong banks) (1/2) (Burst length = 8, /CAS latency = 2)

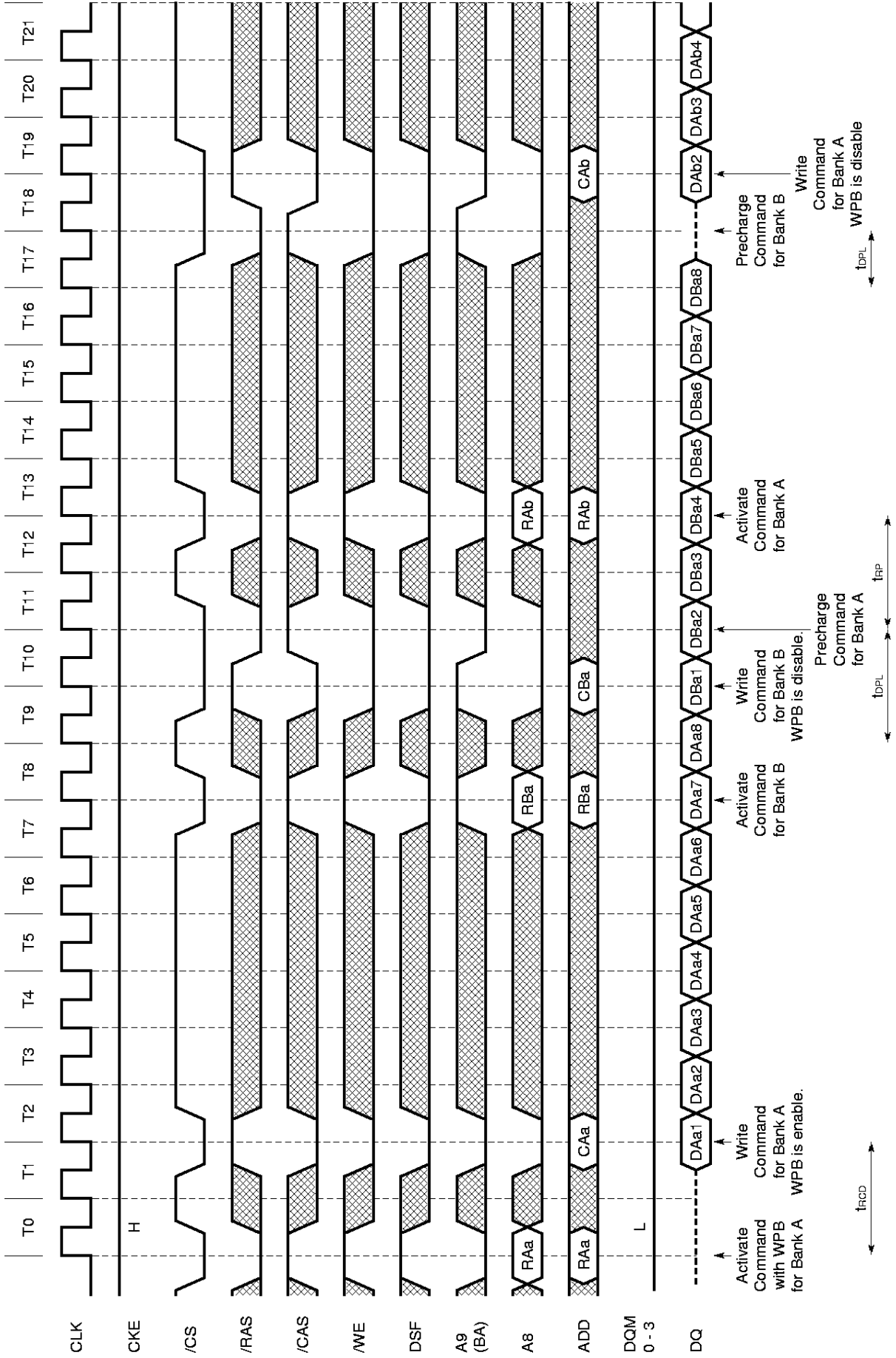

Random Row Write with WPB (Ping-pong banks) (2/2) (Burst length = 8, /CAS latency = 3)

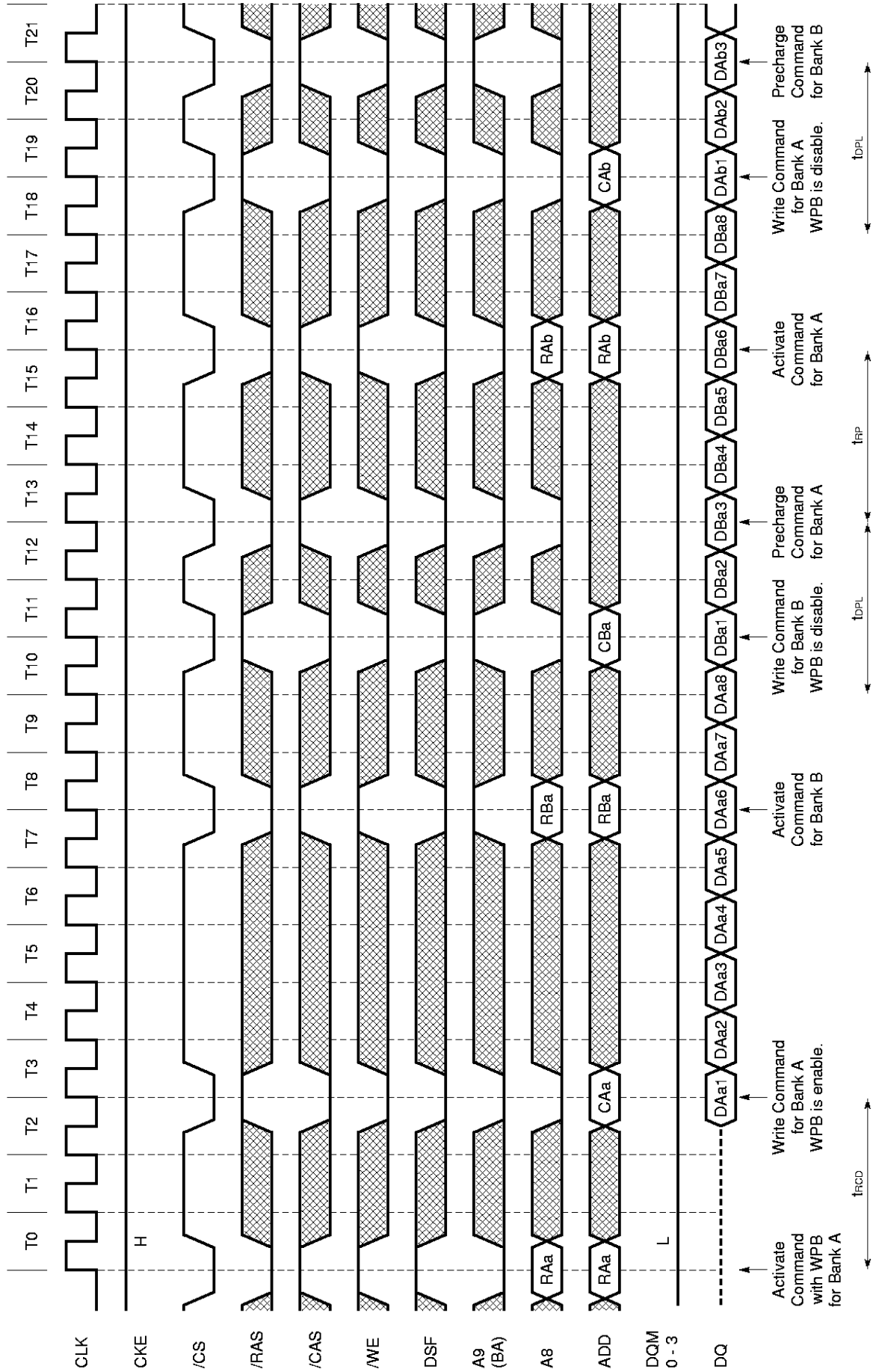

Block Write (page at same bank) (/CAS latency = 3)

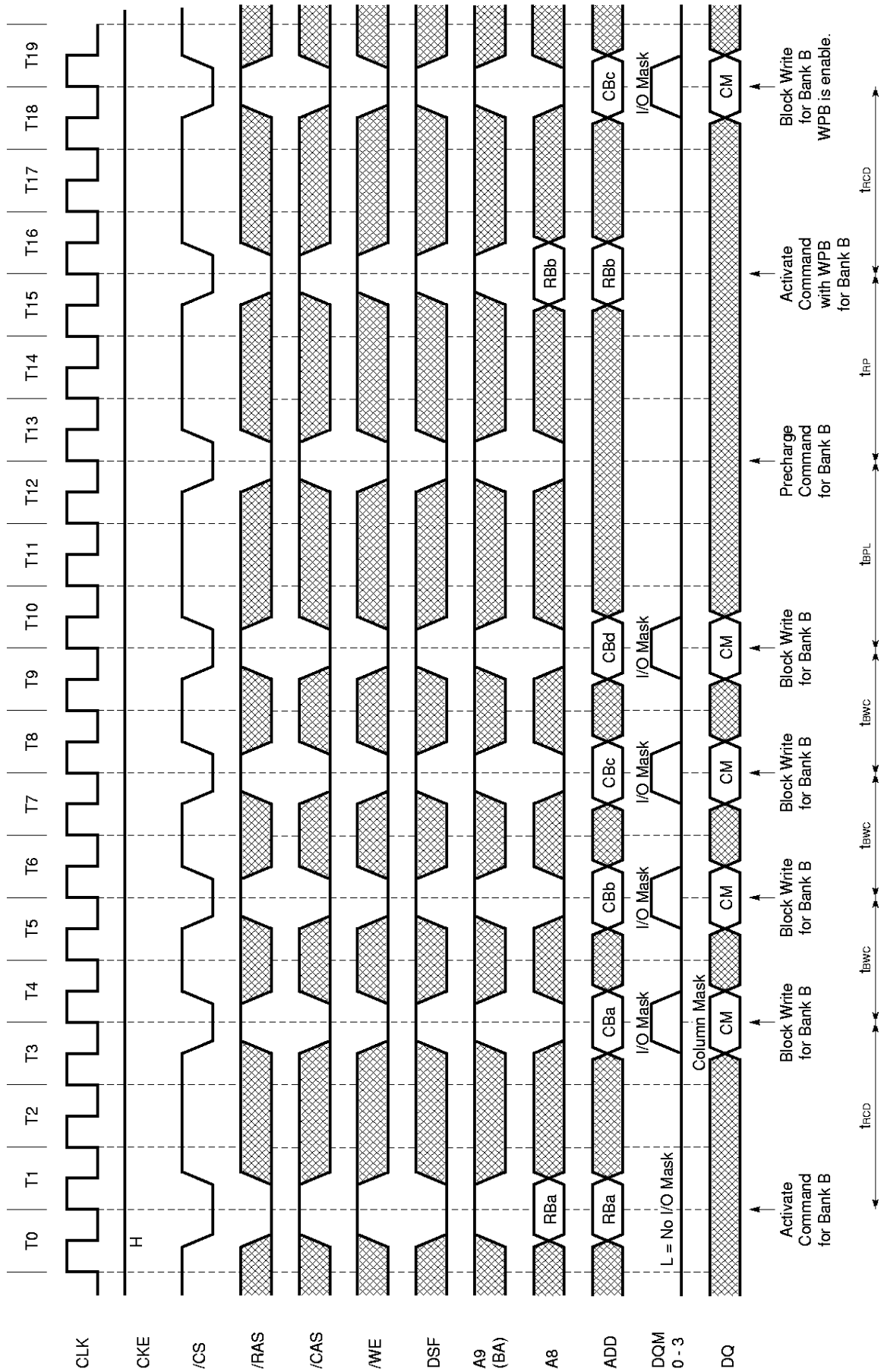

★ Block Write (page at same bank) changing color and mask data (/CAS latency = 3)

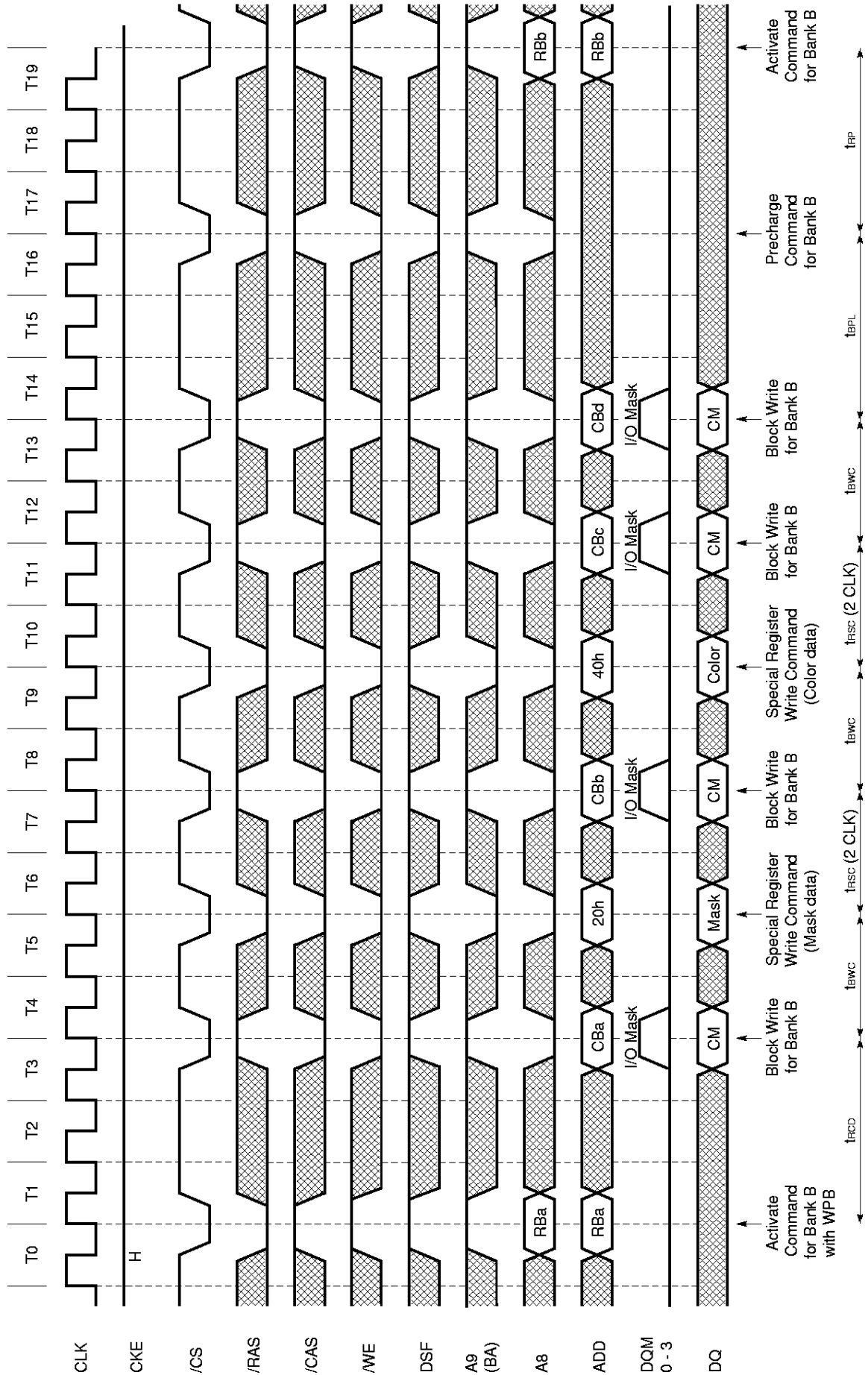

★

16.6 Application Cycles  
 16.6.1 Page Cycles with Same Bank

Random Column Read (page with same bank) (1/2) (Burst length = 4, /CAS latency = 2)

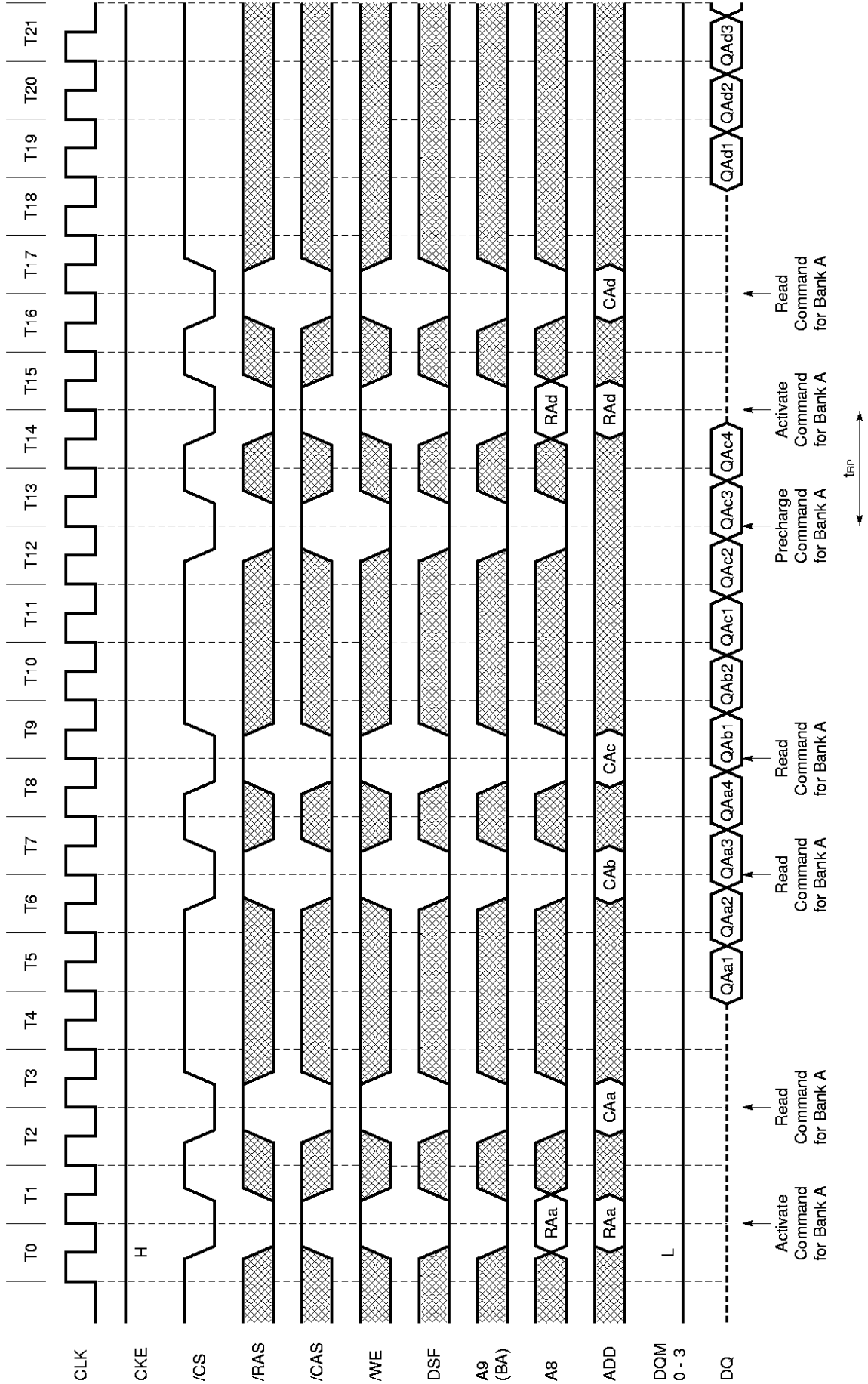

Random Column Read (page with same bank) (2/2) (Burst length = 4, /CAS latency = 3)

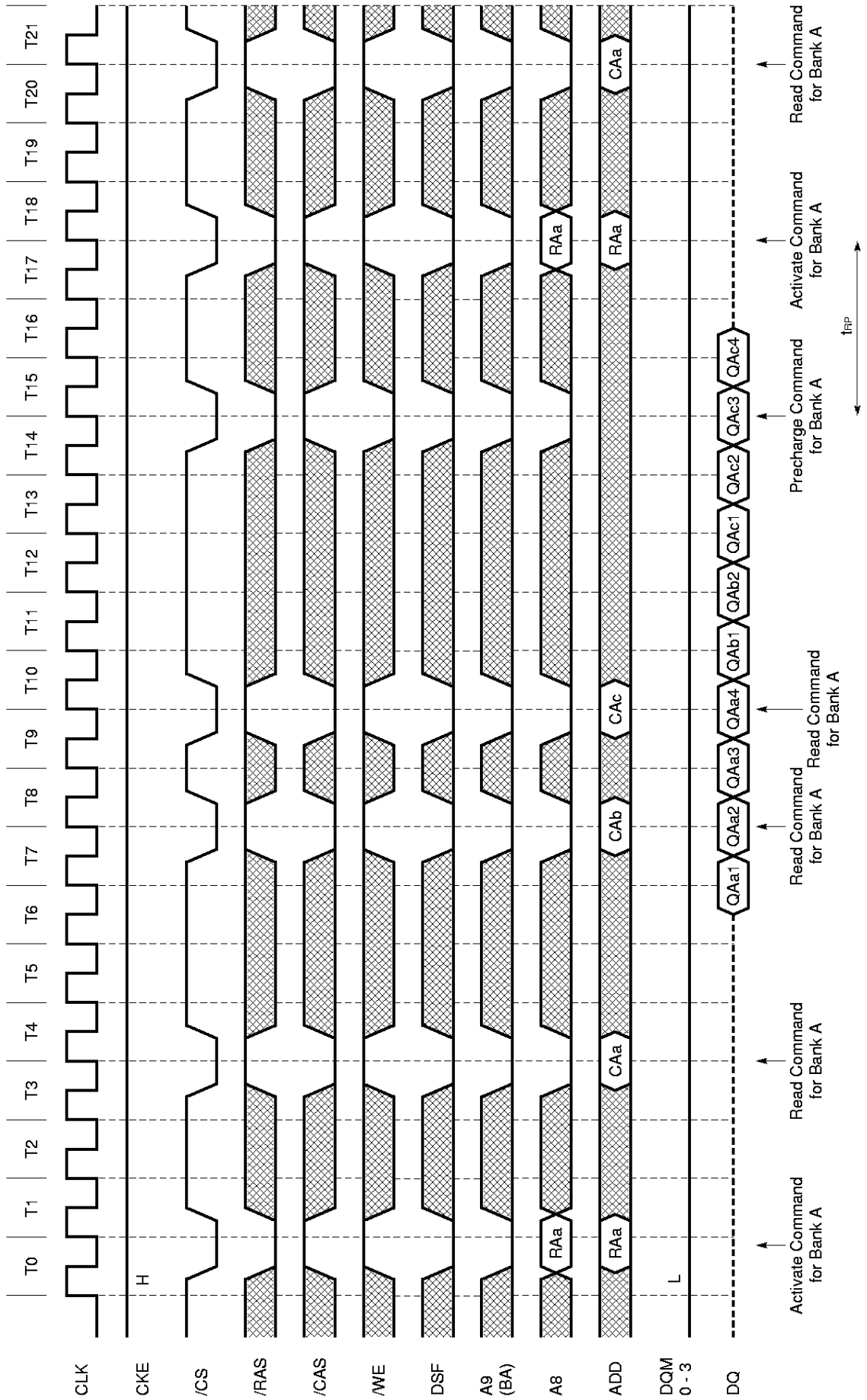



Random Column Write (page with same bank) (1/2) (Burst length = 4, /CAS latency = 2)

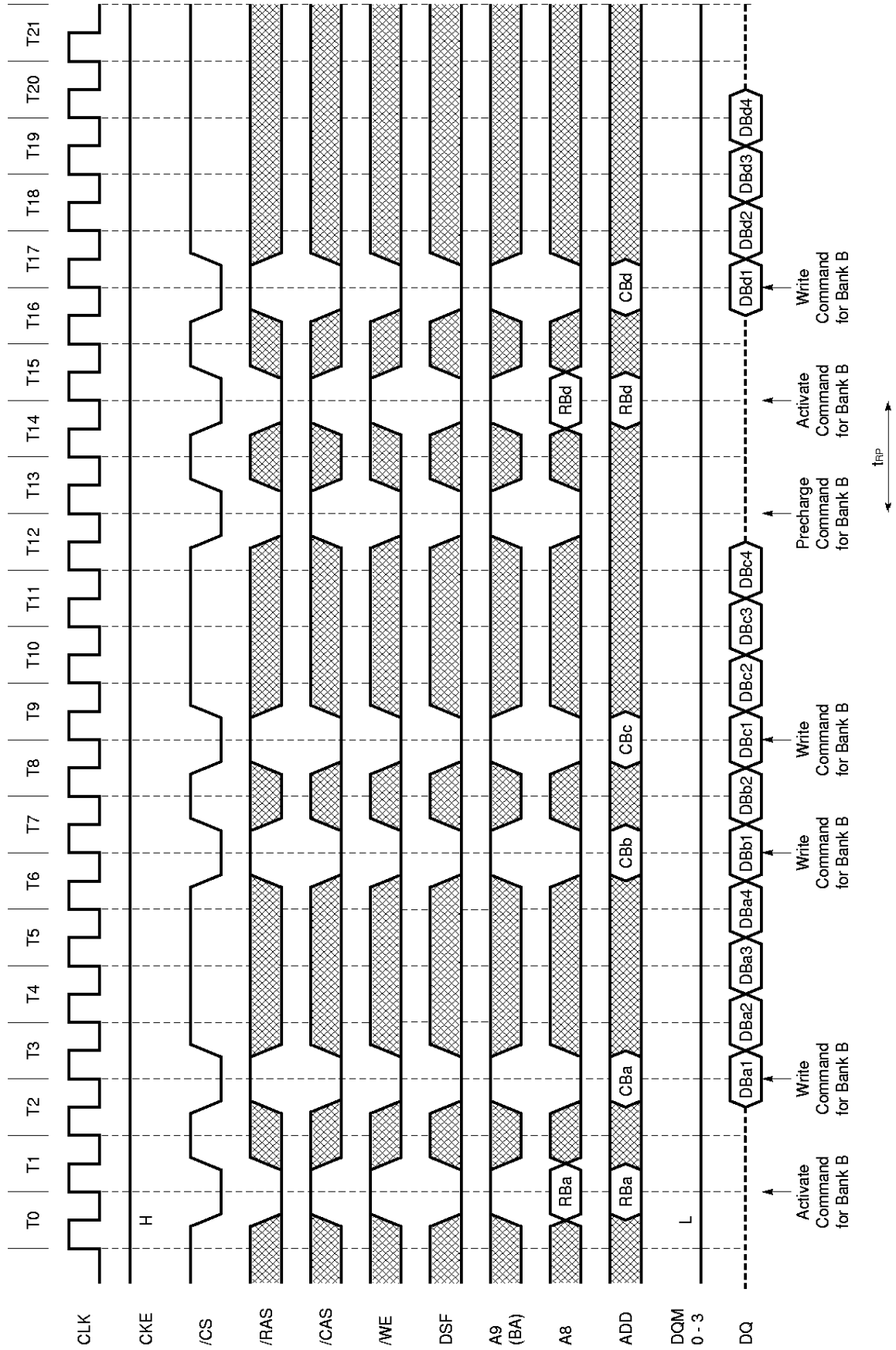

Random Column Write (page with same bank) (2/2) (Burst length = 4, /CAS latency = 3)

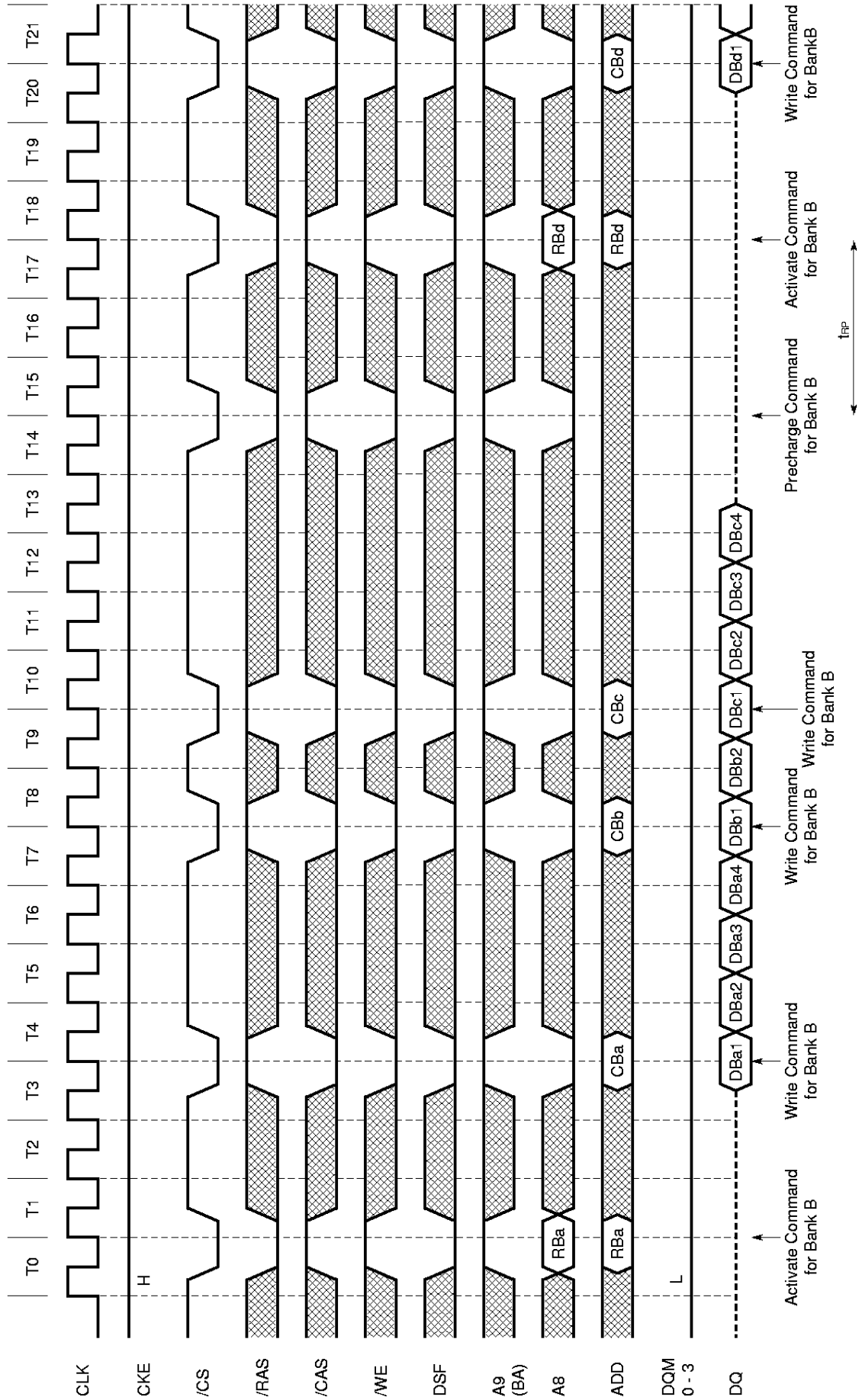

16.6.2 Cycles with Ping-pong Banks

Random Row Read (Ping-pong banks) (1/2) (Burst length = 8, /CAS latency = 2)

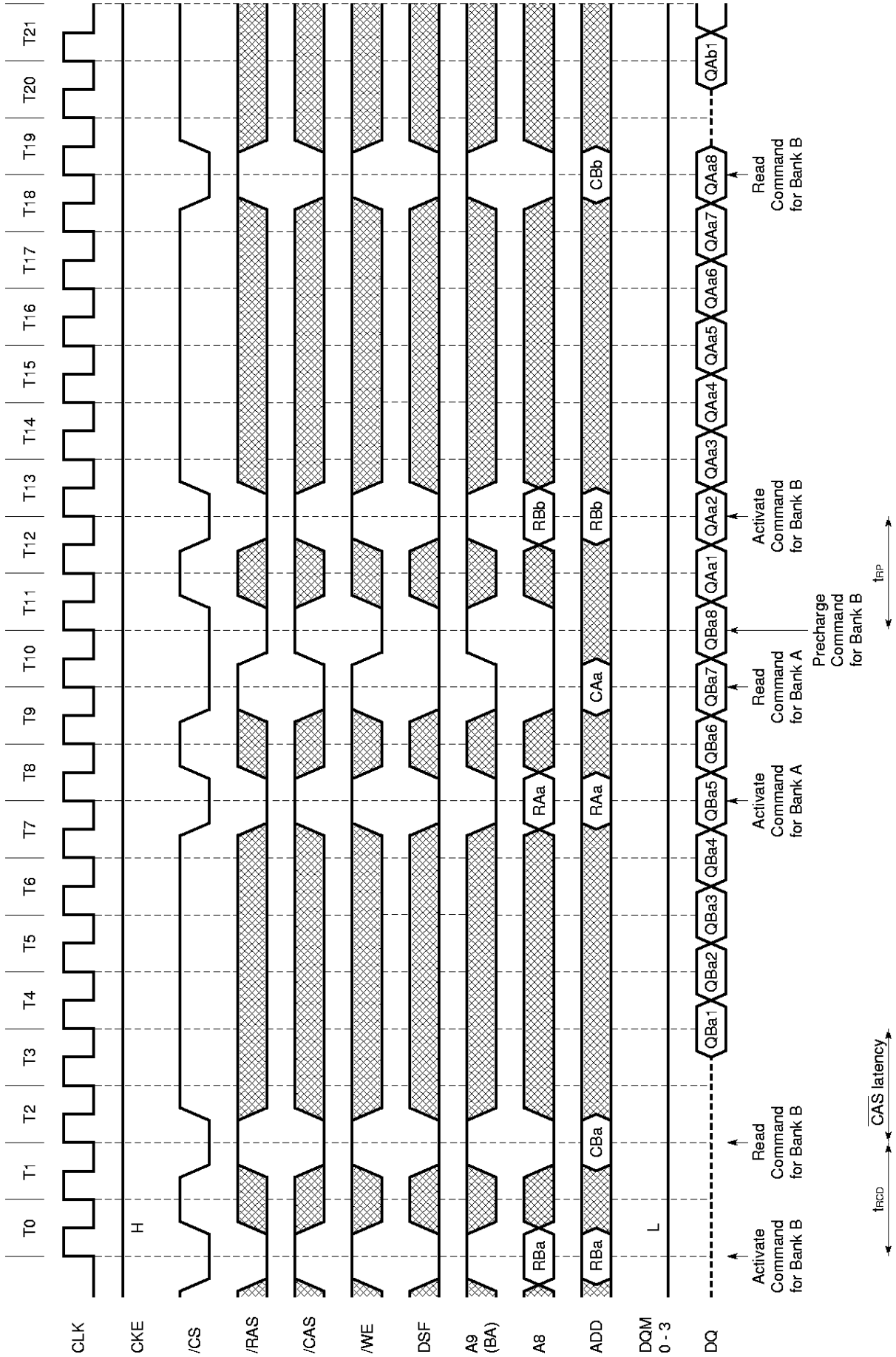

Random Row Read (Ping-pong banks) (2/2) (Burst length = 8, /CAS latency = 3)

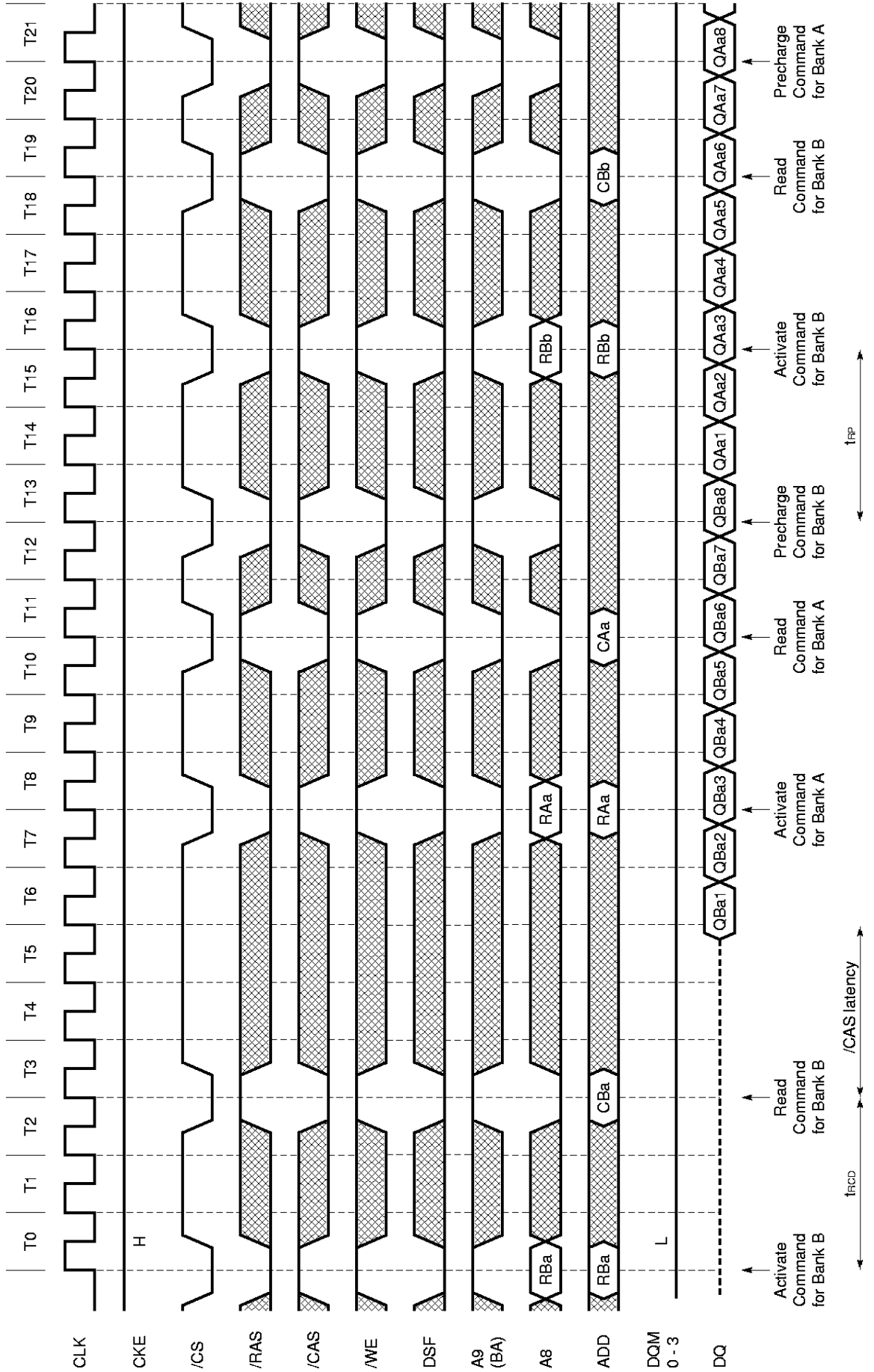

Random Row Write (Ping-pong banks) (1/2) (Burst length = 8, /CAS latency = 2)

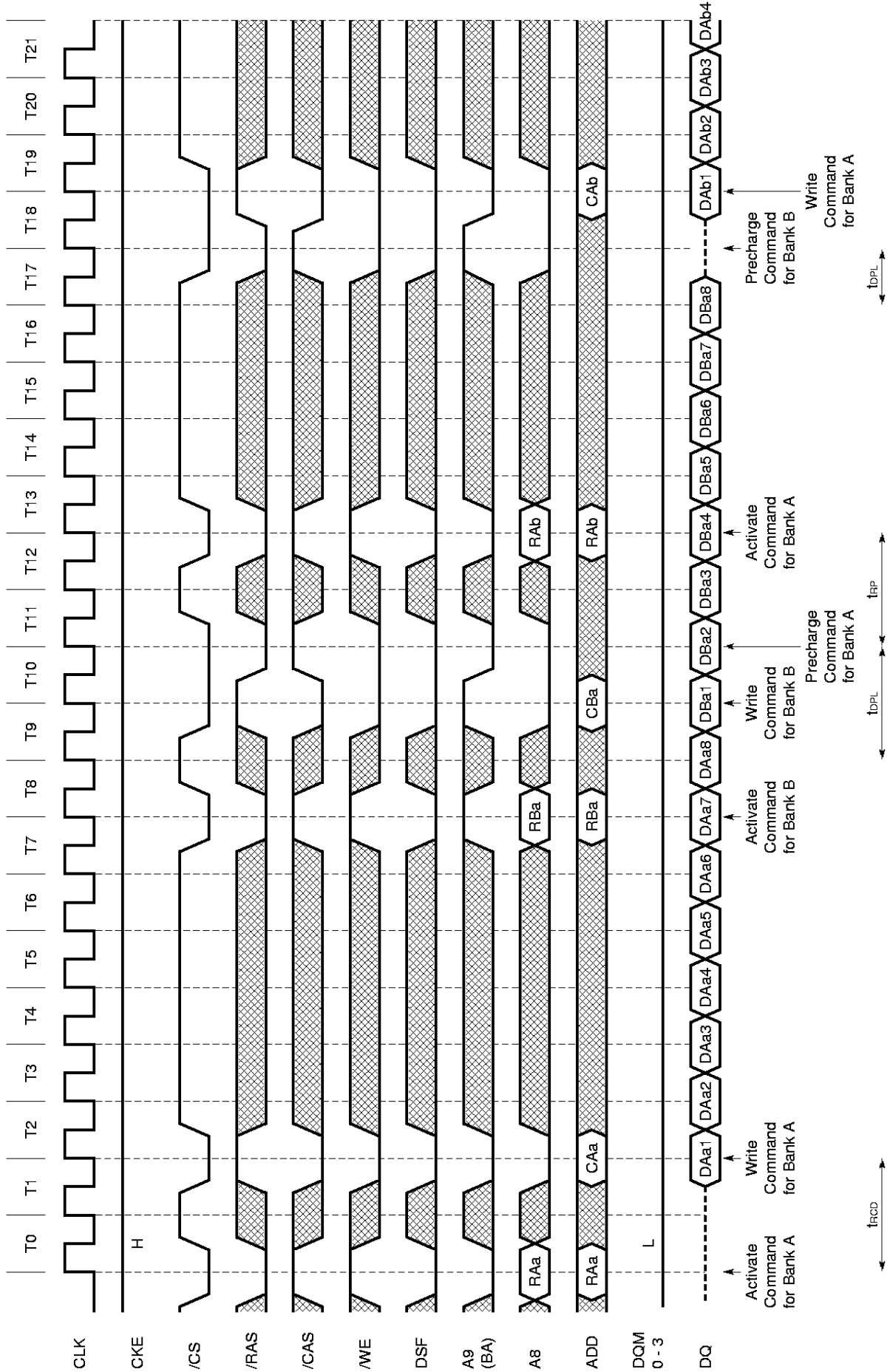

Random Row Write (Ping-pong banks) (2/2) (Burst length = 8, /CAS latency = 3)

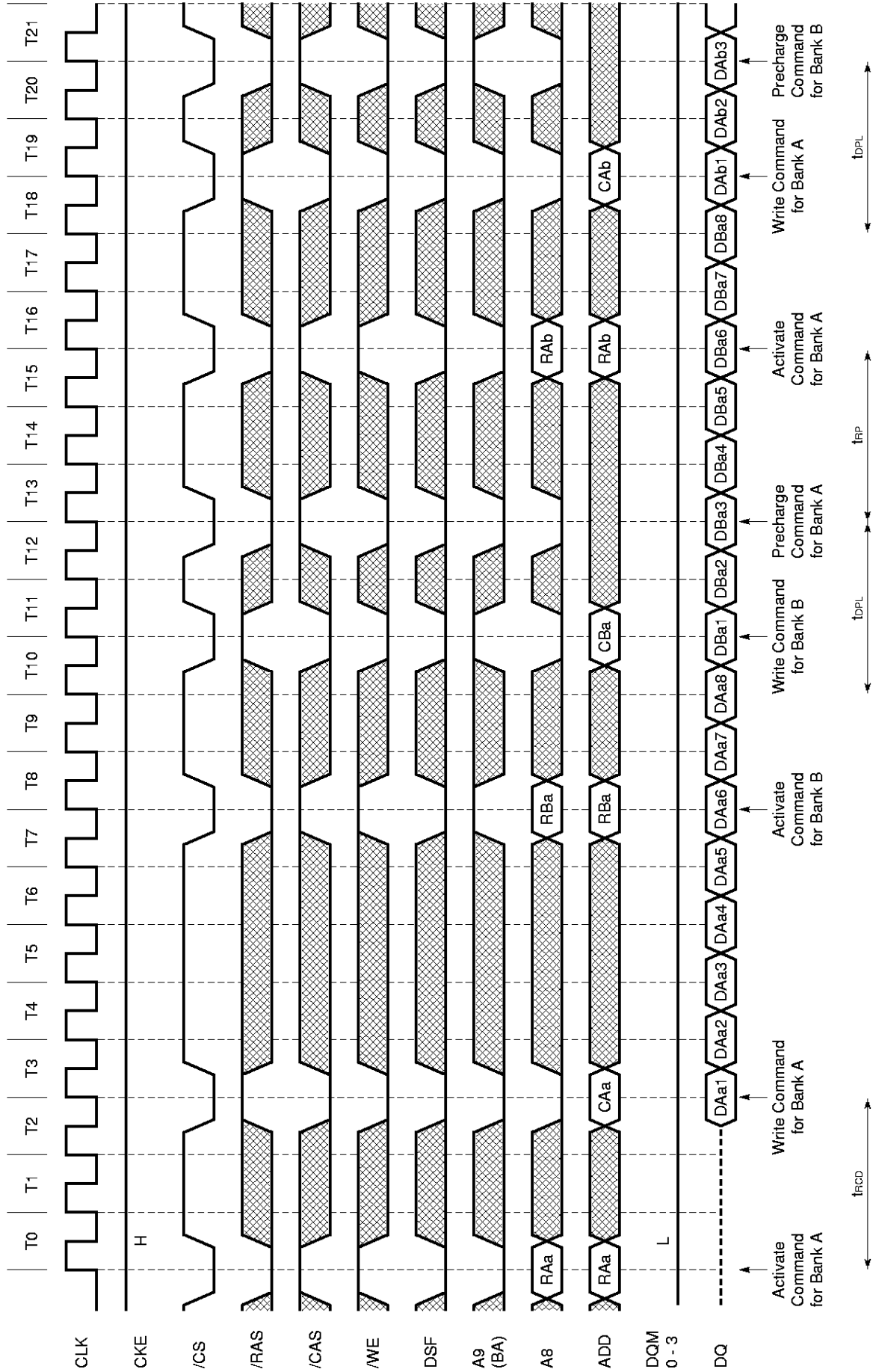

**16.6.3 READ and WRITE Cycles**  
**READ and WRITE (1/2) (Burst length = 4, /CAS latency = 2)**

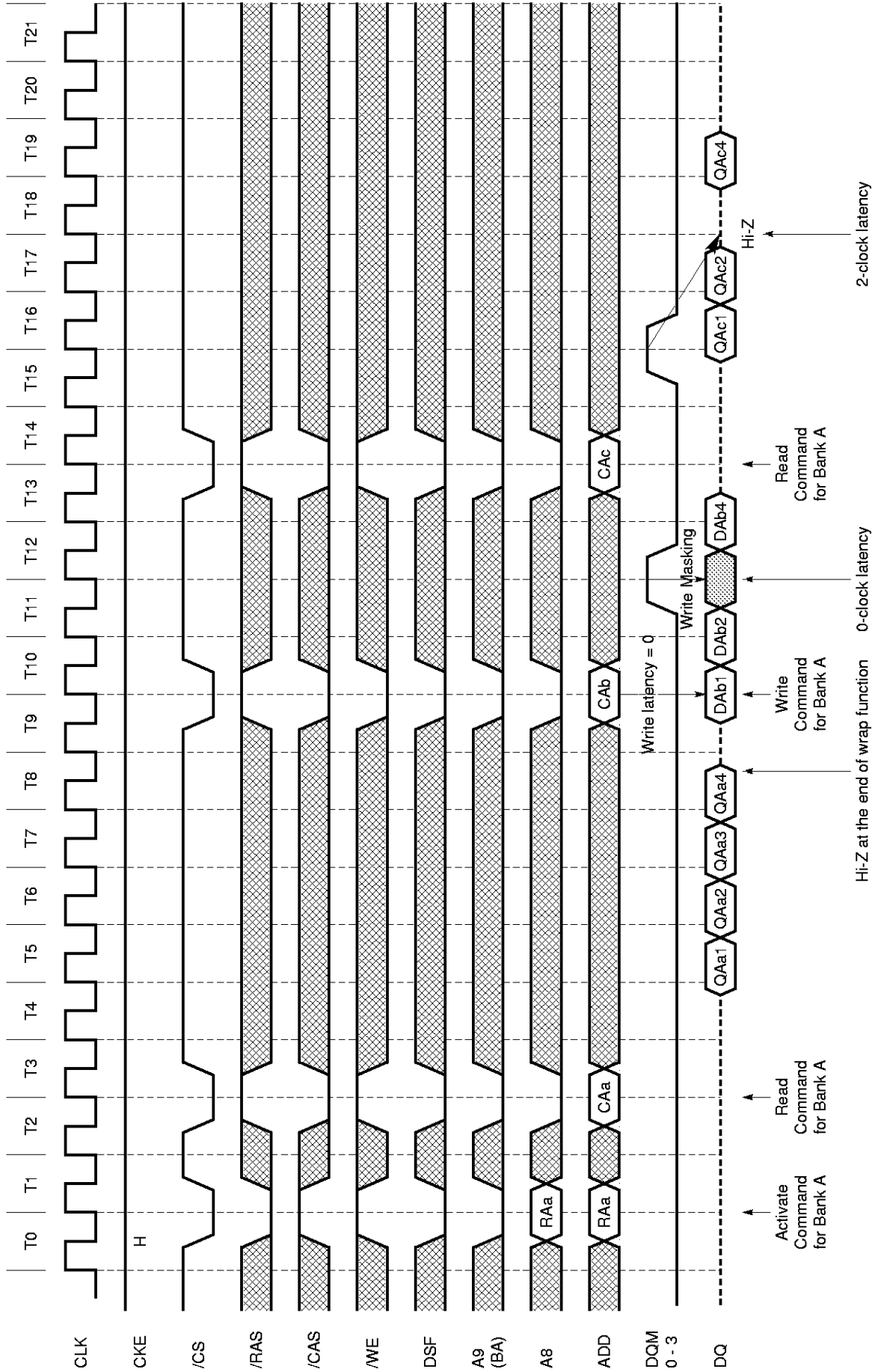

**READ and WRITE (2/2)** (Burst length = 4, /CAS latency = 3)

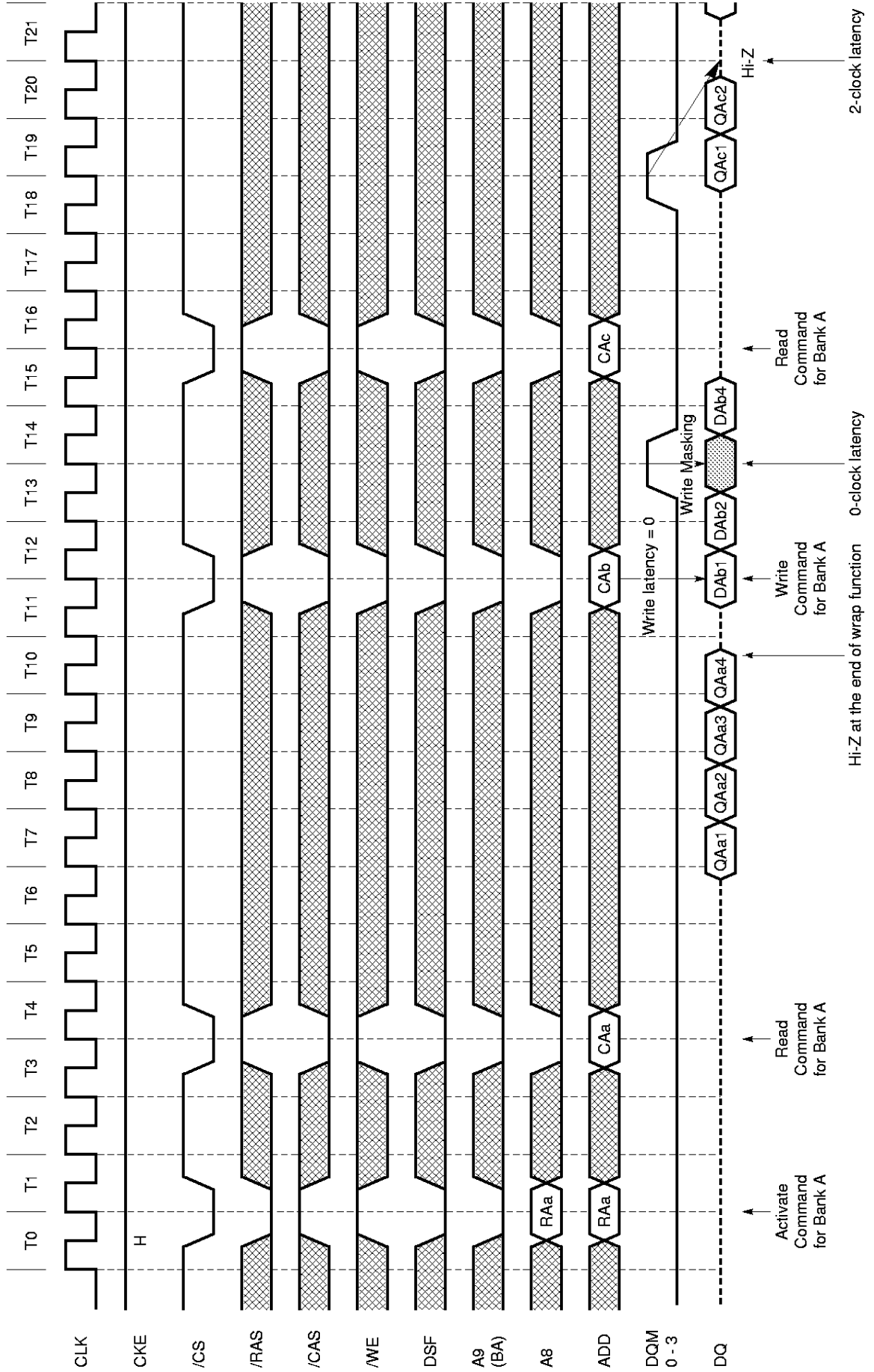



**16.6.4 Full Page Random Cycles**  
**Full Page Random Column Read (Burst length = Full Page, /CAS latency = 2)**

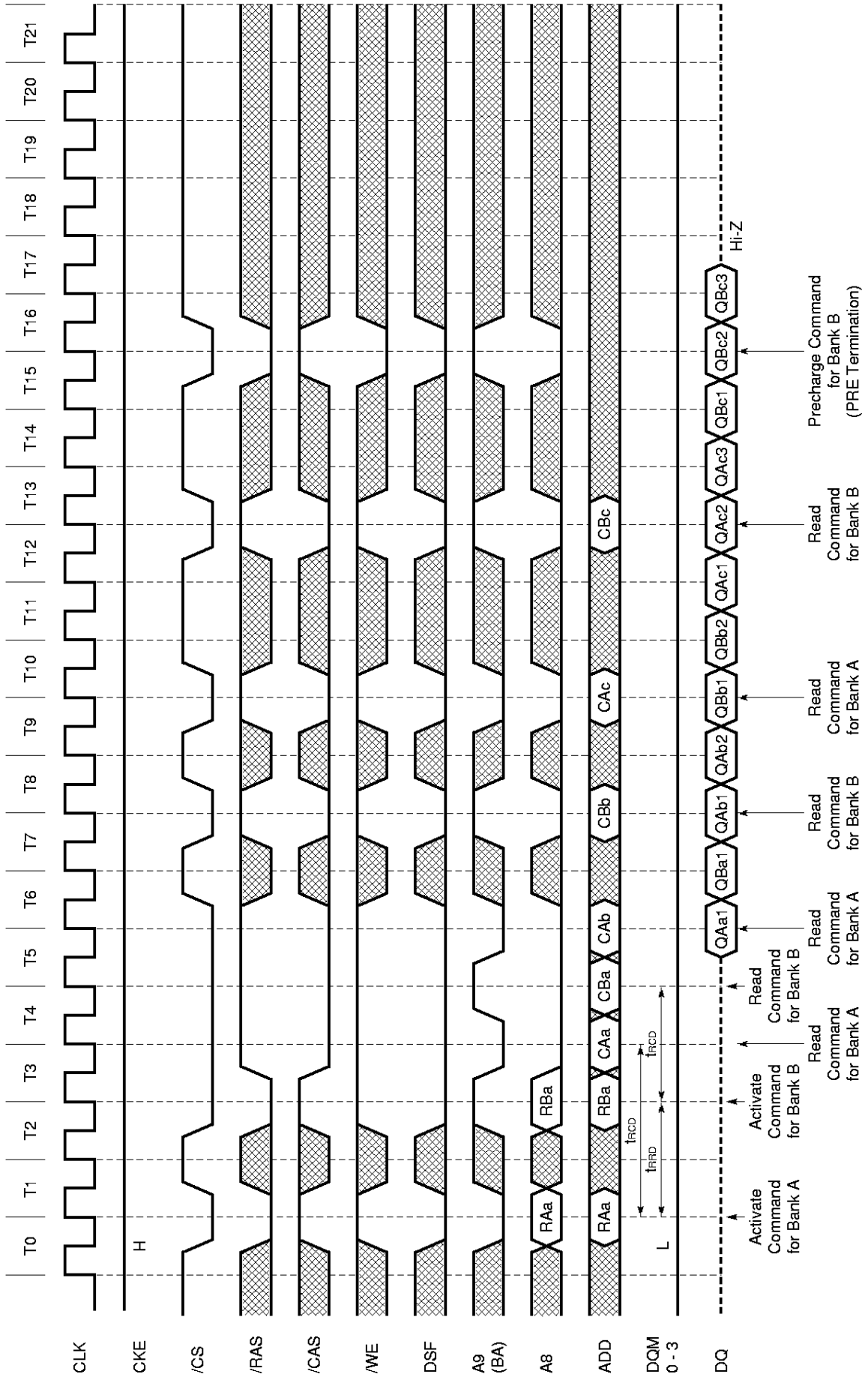

Full Page Random Column Write (Burst length = Full Page, /CAS latency = 2)

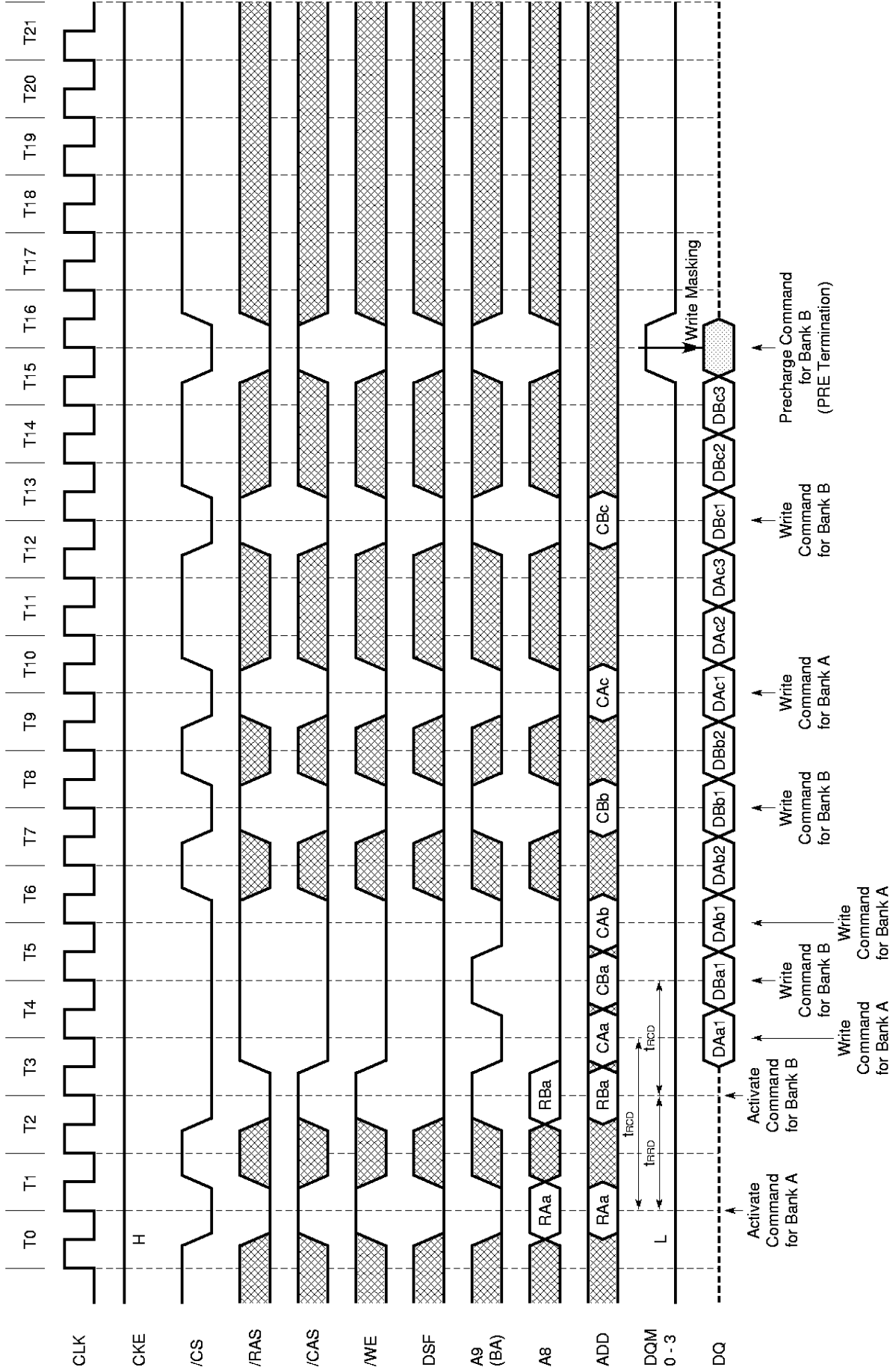

17. Package Drawing

100PIN PLASTIC QFP (14 x 20)

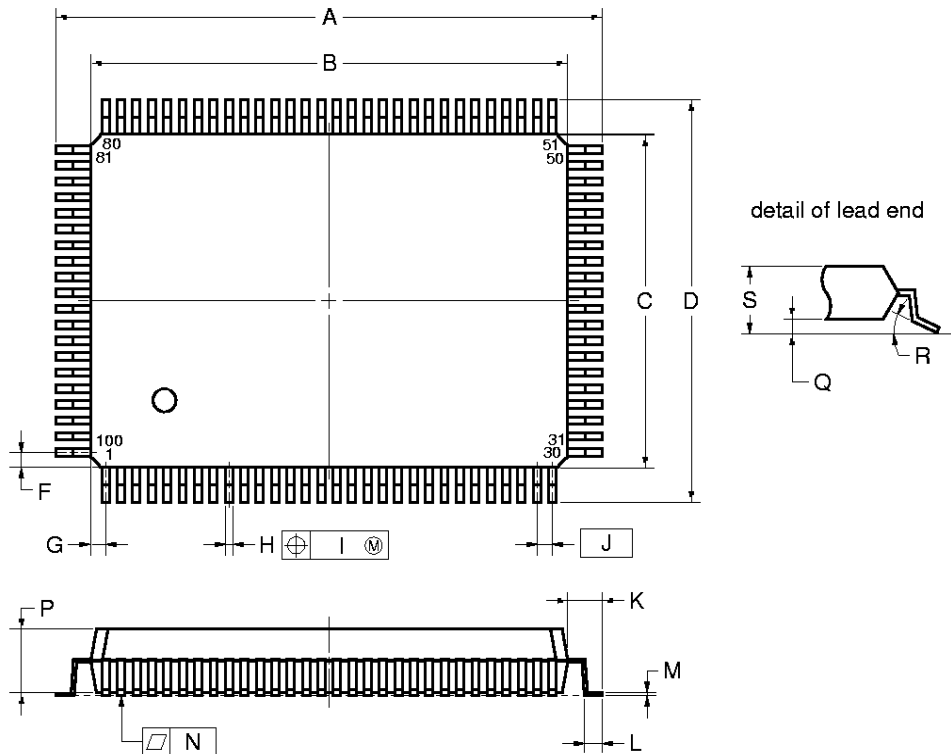

NOTE

Each lead centerline is located within 0.13 mm (0.005 inch) of its true position (T.P.) at maximum material condition.

ITEM	MILLIMETERS	INCHES
A	23.2±0.2	0.913 <sup>+0.009</sup> <sub>-0.008</sub>
B	20.0±0.2	0.787 <sup>+0.009</sup> <sub>-0.008</sub>
C	14.0±0.2	0.551 <sup>+0.009</sup> <sub>-0.008</sub>
D	17.2±0.2	0.677±0.008
F	0.825	0.032
G	0.575	0.023
H	0.32 <sup>+0.08</sup> <sub>-0.07</sub>	0.013±0.003
I	0.13	0.005
J	0.65 (T.P.)	0.026 (T.P.)
K	1.6±0.2	0.063±0.008
L	0.8±0.2	0.031 <sup>+0.009</sup> <sub>-0.008</sub>
M	0.17 <sup>+0.06</sup> <sub>-0.05</sub>	0.007±0.002
N	0.10	0.004
P	2.7	0.106
Q	0.125±0.075	0.005±0.003
R	3° <sup>+7°</sup> <sub>-3°</sub>	3° <sup>+7°</sup> <sub>-3°</sub>
S	3.0 MAX.	0.119 MAX.

S100GF-65-JBT

**18. Recommended Soldering Conditions**

Please consult with our sales offices for soldering conditions of the  $\mu$ PD481850.

**Type of Surface Mount Device**

$\mu$ PD481850GF-JBT : 100-pin Plastic QFP (14 x 20 mm)

## NOTES FOR CMOS DEVICES

### ① PRECAUTION AGAINST ESD FOR SEMICONDUCTORS

**Note:** Strong electric field, when exposed to a MOS device, can cause destruction of the gate oxide and ultimately degrade the device operation. Steps must be taken to stop generation of static electricity as much as possible, and quickly dissipate it once, when it has occurred. Environmental control must be adequate. When it is dry, humidifier should be used. It is recommended to avoid using insulators that easily build static electricity. Semiconductor devices must be stored and transported in an anti-static container, static shielding bag or conductive material. All test and measurement tools including work bench and floor should be grounded. The operator should be grounded using wrist strap. Semiconductor devices must not be touched with bare hands. Similar precautions need to be taken for PW boards with semiconductor devices on it.

### ② HANDLING OF UNUSED INPUT PINS FOR CMOS

**Note:** No connection for CMOS device inputs can be cause of malfunction. If no connection is provided to the input pins, it is possible that an internal input level may be generated due to noise, etc., hence causing malfunction. CMOS device behave differently than Bipolar or NMOS devices. Input levels of CMOS devices must be fixed high or low by using a pull-up or pull-down circuitry. Each unused pin should be connected to V<sub>DD</sub> or GND with a resistor, if it is considered to have a possibility of being an output pin. All handling related to the unused pins must be judged device by device and related specifications governing the devices.

### ③ STATUS BEFORE INITIALIZATION OF MOS DEVICES

**Note:** Power-on does not necessarily define initial status of MOS device. Production process of MOS does not define the initial operation status of the device. Immediately after the power source is turned ON, the devices with reset function have not yet been initialized. Hence, power-on does not guarantee out-pin levels, I/O settings or contents of registers. Device is not initialized until the reset signal is received. Reset operation must be executed immediately after power-on for devices having reset function.

[MEMO]

No part of this document may be copied or reproduced in any form or by any means without the prior written consent of NEC Corporation. NEC Corporation assumes no responsibility for any errors which may appear in this document.

NEC Corporation does not assume any liability for infringement of patents, copyrights or other intellectual property rights of third parties by or arising from use of a device described herein or any other liability arising from use of such device. No license, either express, implied or otherwise, is granted under any patents, copyrights or other intellectual property rights of NEC Corporation or others.

While NEC Corporation has been making continuous effort to enhance the reliability of its semiconductor devices, the possibility of defects cannot be eliminated entirely. To minimize risks of damage or injury to persons or property arising from a defect in an NEC semiconductor device, customers must incorporate sufficient safety measures in its design, such as redundancy, fire-containment, and anti-failure features.

NEC devices are classified into the following three quality grades:

"Standard", "Special", and "Specific". The Specific quality grade applies only to devices developed based on a customer designated "quality assurance program" for a specific application. The recommended applications of a device depend on its quality grade, as indicated below. Customers must check the quality grade of each device before using it in a particular application.

Standard: Computers, office equipment, communications equipment, test and measurement equipment, audio and visual equipment, home electronic appliances, machine tools, personal electronic equipment and industrial robots

Special: Transportation equipment (automobiles, trains, ships, etc.), traffic control systems, anti-disaster systems, anti-crime systems, safety equipment and medical equipment (not specifically designed for life support)

Specific: Aircrafts, aerospace equipment, submersible repeaters, nuclear reactor control systems, life support systems or medical equipment for life support, etc.

The quality grade of NEC devices is "Standard" unless otherwise specified in NEC's Data Sheets or Data Books. If customers intend to use NEC devices for applications other than those specified for Standard quality grade, they should contact an NEC sales representative in advance.

Anti-radioactive design is not implemented in this product.