

Rochester Electronics Manufactured Components

Rochester branded components are manufactured using either die/wafers purchased from the original suppliers or Rochester wafers recreated from the original IP. All recreations are done with the approval of the OCM.

Parts are tested using original factory test programs or Rochester developed test solutions to guarantee product meets or exceed the OCM data sheet.

Quality Overview

- ISO-9001
- AS9120 certification
- Qualified Manufacturers List (QML) MIL-PRF-35835
 - Class Q Military
 - Class V Space Level
- Qualified Suppliers List of Distributors (QSLD)
 - Rochester is a critical supplier to DLA and meets all industry and DLA standards.

Rochester Electronics, LLC is committed to supplying products that satisfy customer expectations for quality and are equal to those originally supplied by industry manufacturers.

The original manufacturer's datasheet accompanying this document reflects the performance and specifications of the Rochester manufactured version of this device. Rochester Electronics guarantees the performance of its semiconductor products to the original OEM specifications. 'Typical' values are for reference purposes only. Certain minimum or maximum ratings may be based on product characterization, design, simulation, or sample testing.

SCAN18245T

Non-Inverting Transceiver with 3-STATE Outputs

General Description

The SCAN18245T is a high speed, low-power bidirectional line driver featuring separate data inputs organized into dual 9-bit bytes with byte-oriented output enable and direction control signals. This device is compliant with IEEE 1149.1 Standard Test Access Port and Boundary Scan Architecture with the incorporation of the defined boundary-scan test logic and test access port consisting of Test Data Input (TDI), Test Data Out (TDO), Test Mode Select (TMS), and Test Clock (TCK).

Features

- IEEE 1149.1 (JTAG) Compliant
- Dual output enable control signals
- 3-STATE outputs for bus-oriented applications
- 9-bit data busses for parity applications
- Reduced-swing outputs source 32 mA/sink 64 mA
- Guaranteed to drive 50Ω transmission line to TTL input levels of 0.8V and 2.0V
- TTL compatible inputs
- 25 mil pitch SSOP (Shrink Small Outline Package)
- Includes CLAMP and HIGHZ instructions
- Member of Fairchild's SCAN Products

Ordering Code:

Order Number	Package Number	Package Description
SCAN18245TSSC	MS56A	56-Lead Shrink Small Outline Package (SSOP), JEDEC MO-118, 0.300 Wide

Devices also available in Tape and Reel. Specify by appending the suffix letter "X" to the ordering code.

Connection Diagram

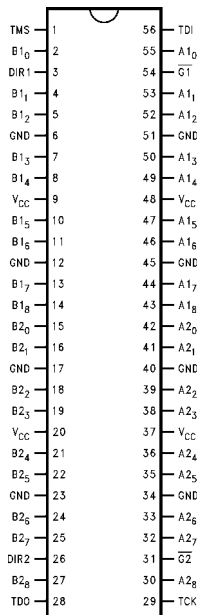

Pin Descriptions

Pin Names	Description
A1 ₍₀₋₈₎	Side A1 Inputs or 3-STATE Outputs
B1 ₍₀₋₈₎	Side B1 Inputs or 3-STATE Outputs
A2 ₍₀₋₈₎	Side A2 Inputs or 3-STATE Outputs
B2 ₍₀₋₈₎	Side B2 Inputs or 3-STATE Outputs
G1, G2	Output Enable Pins
DIR1, DIR2	Direction of Data Flow Pins

Truth Table

Inputs		A1 (0-8)		B1 (0-8)	
$\overline{G1}$	DIR1				
L	L	H	←	H	
L	L	L	←	L	
L	H	H	→	H	
L	H	L	→	L	
H	X	Z		Z	

H= HIGH Voltage Level
L= LOW Voltage Level

Inputs		A2 (0-8)		B2 (0-8)	
$\overline{G2}$	DIR2				
L	L	H	←	H	
L	L	L	←	L	
L	H	H	→	H	
L	H	L	→	L	
H	X	Z		Z	

X= Immaterial
Z= High Impedance

Functional Description

The SCAN18245 consists of two sets of nine non-inverting bidirectional buffers with 3-STATE outputs and is intended for bus-oriented applications. Direction pins (DIR1 and DIR2) LOW enables data from B Ports to A Ports, when

HIGH enables data from A Ports to B Ports. The Output Enable pins ($\overline{G1}$ and $\overline{G2}$) when HIGH disables both A and B Ports by placing them in a high impedance condition.

Block Diagrams

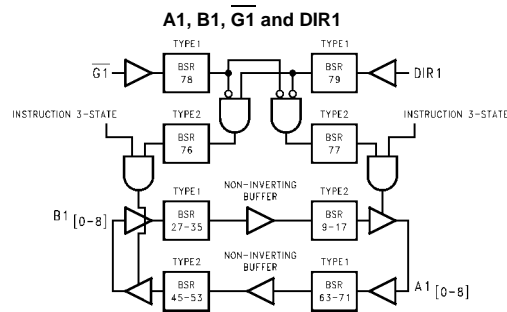

Note: BSR stands for Boundary Scan Register.

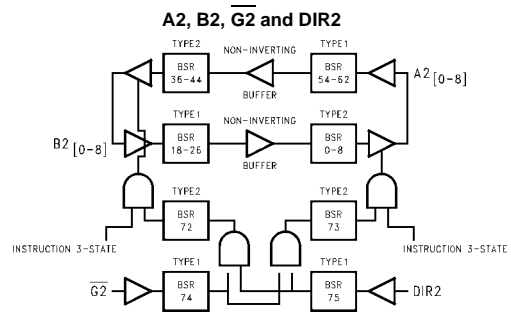

Note: BSR stands for Boundary Scan Register.

Tap Controller

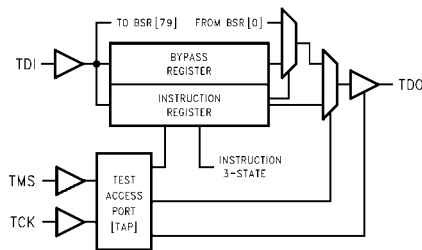

Description of Boundary-Scan Circuitry

The scan cells used in the BOUNDARY-SCAN register are one of the following two types depending upon their location. Scan cell TYPE1 is intended to solely observe system data, while TYPE2 has the additional ability to control system data. (See IEEE Standard 1149.1 *Figure 10–11* for a further description of scan cell TYPE1 and *Figure 10–12* for a further description of scan cell TYPE2.)

Scan cell TYPE1 is located on each system input pin while scan cell TYPE2 is located at each system output pin as well as at each of the two internal active-high output enable signals. AOE controls the activity of the A-outputs while BOE controls the activity of the B-outputs. Each will activate their respective outputs by loading a logic high.

The BYPASS register is a single bit shift register stage identical to scan cell TYPE1. It captures a fixed logic low.

Bypass Register Scan Chain Definition

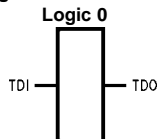

The INSTRUCTION register is an eight-bit register which captures the value 00111101.

The two least significant bits of this captured value (01) are required by IEEE Std 1149.1. The upper six bits are unique to the SCAN18245T device. SCAN CMOS Test Access Logic devices do not include the IEEE 1149.1 optional identification register. Therefore, this unique captured value can be used as a “pseudo ID” code to confirm that the correct device is placed in the appropriate location in the boundary scan chain.

Instruction Register Scan Chain Definition

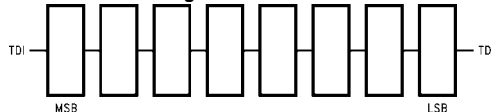

MSB → LSB

Instruction Code	Instruction
00000000	EXTEST
10000001	SAMPLE/PRELOAD
10000010	CLAMP
00000011	HIGHZ
All Others	BYPASS

Scan Cell TYPE1

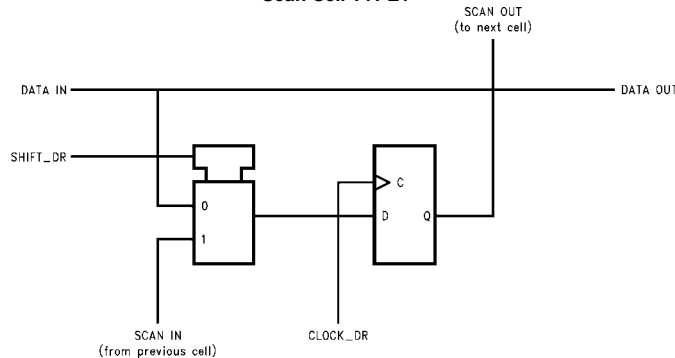

Scan Cell TYPE2

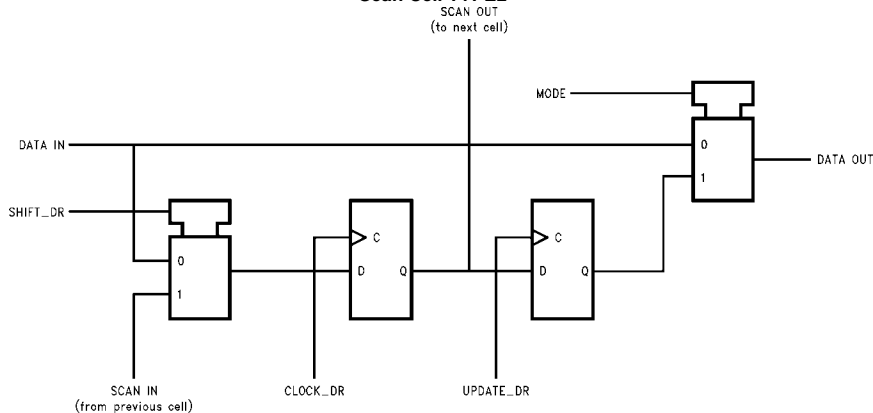

**Boundary-Scan Register
Scan Chain Definition (80 Bits in Length)**

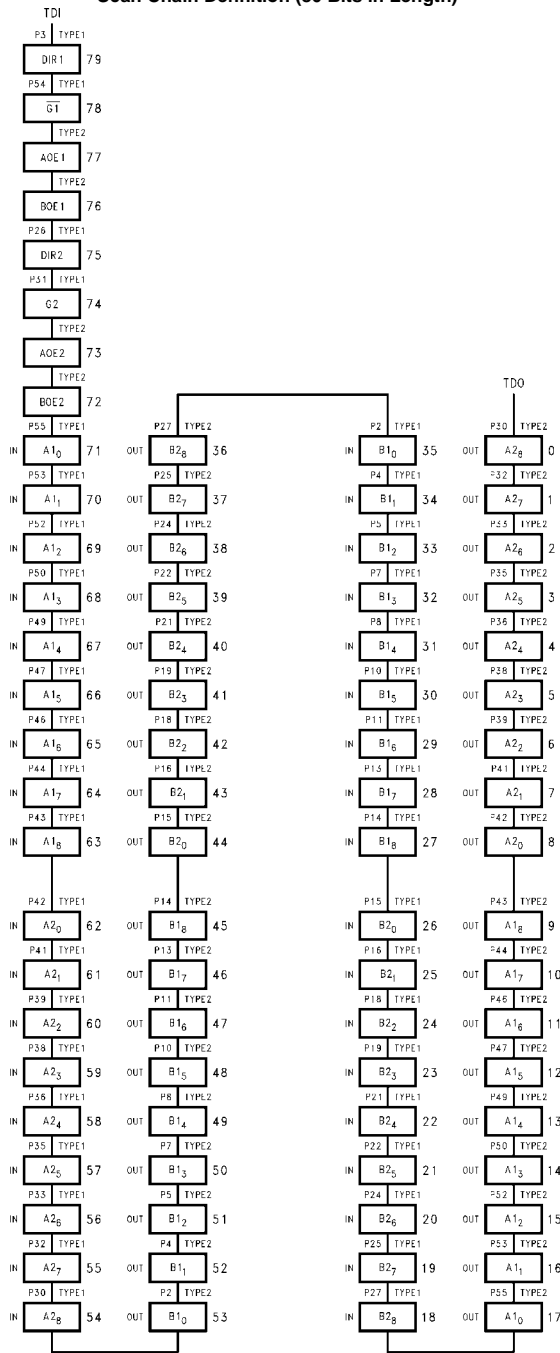

Boundary-Scan Register Definition Index

Bit No.	Pin Name	Pin No.	Pin Type	Scan Cell Type	
79	DIR1	3	Input	TYPE1	Control Signals
78	$\overline{G1}$	54	Input	TYPE1	
77	AOE ₁		Internal	TYPE2	
76	BOE ₁		Internal	TYPE2	
75	DIR2	26	Input	TYPE1	
74	$\overline{G2}$	31	Input	TYPE1	
73	AOE ₂		Internal	TYPE2	
72	BOE ₂		Internal	TYPE2	
71	A1 ₀	55	Input	TYPE1	A1-in
70	A1 ₁	53	Input	TYPE1	
69	A1 ₂	52	Input	TYPE1	
68	A1 ₃	50	Input	TYPE1	
67	A1 ₄	49	Input	TYPE1	
66	A1 ₅	47	Input	TYPE1	
65	A1 ₆	46	Input	TYPE1	
64	A1 ₇	44	Input	TYPE1	
63	A1 ₈	43	Input	TYPE1	
62	A2 ₀	42	Input	TYPE1	A2-in
61	A2 ₁	41	Input	TYPE1	
60	A2 ₂	39	Input	TYPE1	
59	A2 ₃	38	Input	TYPE1	
58	A2 ₄	36	Input	TYPE1	
57	A2 ₅	35	Input	TYPE1	
56	A2 ₆	33	Input	TYPE1	
55	A2 ₇	32	Input	TYPE1	
54	A2 ₈	30	Input	TYPE1	
53	B1 ₀	2	Output	TYPE2	B1-out
52	B1 ₁	4	Output	TYPE2	
51	B1 ₂	5	Output	TYPE2	
50	B1 ₃	7	Output	TYPE2	
49	B1 ₄	8	Output	TYPE2	
48	B1 ₅	10	Output	TYPE2	
47	B1 ₆	11	Output	TYPE2	
46	B1 ₇	13	Output	TYPE2	
45	B1 ₈	14	Output	TYPE2	
44	B2 ₀	15	Output	TYPE2	B2-out
43	B2 ₁	16	Output	TYPE2	
42	B2 ₂	18	Output	TYPE2	
41	B2 ₃	19	Output	TYPE2	
40	B2 ₄	21	Output	TYPE2	
39	B2 ₅	22	Output	TYPE2	
38	B2 ₆	24	Output	TYPE2	
37	B2 ₇	25	Output	TYPE2	
36	B2 ₈	27	Output	TYPE2	

Bit No.	Pin Name	Pin No.	Pin Type	Scan Cell Type	
35	B1 ₀	2	Input	TYPE1	B1-in
34	B1 ₁	4	Input	TYPE1	
33	B1 ₂	5	Input	TYPE1	
32	B1 ₃	7	Input	TYPE1	
31	B1 ₄	8	Input	TYPE1	
30	B1 ₅	10	Input	TYPE1	
29	B1 ₆	11	Input	TYPE1	
28	B1 ₇	13	Input	TYPE1	
27	B1 ₈	14	Input	TYPE1	
26	B2 ₀	15	Input	TYPE1	B2-in
25	B2 ₁	16	Input	TYPE1	
24	B2 ₂	18	Input	TYPE1	
23	B2 ₃	19	Input	TYPE1	
22	B2 ₄	21	Input	TYPE1	
21	B2 ₅	22	Input	TYPE1	
20	B2 ₆	24	Input	TYPE1	
19	B2 ₇	25	Input	TYPE1	
18	B2 ₈	27	Input	TYPE1	
17	A1 ₀	55	Output	TYPE2	A1-out
16	A1 ₁	53	Output	TYPE2	
15	A1 ₂	52	Output	TYPE2	
14	A1 ₃	50	Output	TYPE2	
13	A1 ₄	49	Output	TYPE2	
12	A1 ₅	47	Output	TYPE2	
11	A1 ₆	46	Output	TYPE2	
10	A1 ₇	44	Output	TYPE2	
9	A1 ₈	43	Output	TYPE2	
8	A2 ₀	42	Output	TYPE2	A2-out
7	A2 ₁	41	Output	TYPE2	
6	A2 ₂	39	Output	TYPE2	
5	A2 ₃	38	Output	TYPE2	
4	A2 ₄	36	Output	TYPE2	
3	A2 ₅	35	Output	TYPE2	
2	A2 ₆	33	Output	TYPE2	
1	A2 ₇	32	Output	TYPE2	
0	A2 ₈	30	Output	TYPE2	

Absolute Maximum Ratings(Note 1)

Supply Voltage (V_{CC})	-0.5V to +7.0V
DC Input Diode Current (I_{IK})	
$V_I = -0.5V$	-20 mA
$V_I = V_{CC} + 0.5V$	+20 mA
DC Output Diode Current (I_{OK})	
$V_O = -0.5V$	-20 mA
$V_O = V_{CC} + 0.5V$	+20 mA
DC Output Voltage (V_O)	-0.5V to $V_{CC} + 0.5V$
DC Output Source/Sink Current (I_O)	± 70 mA
DC V_{CC} or Ground Current	
Per Output Pin	± 70 mA
Junction Temperature	
SSOP	+140°C
Storage Temperature	-65°C to +150°C
ESD (Min)	2000V

Recommended Operating Conditions

Supply Voltage (V_{CC})	
SCAN Products	4.5V to 5.5V
Input Voltage (V_I)	0V to V_{CC}
Output Voltage (V_O)	0V to V_{CC}
Operating Temperature (T_A)	-40°C to +85°C
Minimum Input Edge Rate $\Delta V/\Delta t$	125 mV/ns
V_{IN} from 0.8V to 2.0V	
V_{CC} @ 4.5V, 5.5V	

Note 1: Absolute maximum ratings are those values beyond which damage to the device may occur. The databook specifications should be met, without exception, to ensure that the system design is reliable over its power supply, temperature, and output/input loading variables. Fairchild does not recommend operation of SCAN circuits outside databook specifications.

DC Electrical Characteristics

Symbol	Parameter	V_{CC} (V)	$T_A = +25^\circ\text{C}$		$T_A = -40^\circ\text{C to } +85^\circ\text{C}$		Units	Conditions
			Typ	Guaranteed Limits				
V_{IH}	Minimum HIGH Input Voltage	4.5	1.5	2.0	2.0	V	$V_{OUT} = 0.1V$ or $V_{CC} - 0.1V$	
		5.5	1.5	2.0	2.0			
V_{IL}	Maximum LOW Input Voltage	4.5	1.5	0.8	0.8	V	$V_{OUT} = 0.1V$ or $V_{CC} - 0.1V$	
		5.5	1.5	0.8	0.8			
V_{OH}	Minimum HIGH Output Voltage (Note 2)	4.5		3.15	3.15	V	$I_{OUT} = -50 \mu A$	
		5.5		4.15	4.15			
		4.5		2.4	2.4	V	$V_{IN} = V_{IL}$ or V_{IH} $I_{OH} = -32 \text{ mA}$	
		5.5		2.4	2.4			
V_{OL}	Maximum LOW Output Voltage (Note 2)	4.5		0.1	0.1	V	$I_{OUT} = 50 \mu A$	
		5.5		0.1	0.1			
		4.5		0.55	0.55	V	$V_{IN} = V_{IL}$ or V_{IH} $I_{OL} = 64 \text{ mA}$	
		5.5		0.55	0.55			
I_{IN}	Maximum Input Leakage Current	5.5		± 0.1	± 1.0	μA	$V_I = V_{CC}, \text{ GND}$	
I_{IN} TDI, TMS	Maximum Input Leakage	5.5		2.8	3.6	μA	$V_I = V_{CC}$	
				-385	-385	μA	$V_I = \text{GND}$	
				-160	-160	μA	$V_I = \text{GND}$	
I_{OLD}	Minimum Dynamic	5.5		94	94	mA	$V_{OLD} = 0.8V \text{ Max}$	
I_{OHD}	Output Current (Note 3)			-40	-40	mA	$V_{OHD} = 2.0V \text{ Min}$	
I_{OZT}	Maximum I/O Leakage Current	5.5		± 0.6	± 6.0	μA	$V_I (\text{OE}) = V_{IL}$ $V_{IH} V_I = V_{CC}, \text{ GND}$ $V_O = V_{CC}, \text{ GND}$	
I_{OS}	Output Short Circuit Current	5.5		-100	-100	mA (min)	$V_O = 0V$	
I_{CC}	Maximum Quiescent Supply Current	5.5		16.0	88	μA	$V_O = \text{HIGH}$ TDI, TMS = V_{CC}	
		5.5		750	820	μA	$V_O = \text{HIGH}$ TDI, TMS = GND	

DC Electrical Characteristics (Continued)								
Symbol	Parameter	V _{CC} (V)	T _A = +25°C		T _A = -40°C to +85°C		Units	Conditions
			Typ	Guaranteed Limits				
I _{CC1}	Maximum I _{CC} Per Input	5.5		2.0	2.0		mA	V _I = V _{CC} -2.1V
		5.5		2.15	2.15		mA	V _I = V _{CC} -2.1V TDI/TMS Pin, test one with the other floating
<p>Note 2: All outputs loaded; thresholds associated with output under test.</p> <p>Note 3: Maximum test duration 2.0 ms, one output loaded at a time.</p>								
Noise Specifications								
Symbol	Parameter	V _{CC} (V)	T _A = +25°C		T _A = -40°C to +85°C		Units	
			Typ	Guaranteed Limits				
V _{OLP}	Maximum HIGH Output Noise (Note 5)(Note 6)	5.0	1.0	1.5			V	
V _{OLV}	Minimum LOW Output Noise (Note 5)(Note 6)	5.0	-0.6	-1.2			V	
V _{OHP}	Maximum Overshoot (Note 4)(Note 6)	5.0	V _{OH} +1.0	V _{OH} +1.5			V	
V _{OHV}	Minimum V _{CC} Droop (Note 4)(Note 6)	5.0	V _{OH} -1.0	V _{OH} -1.8			V	
V _{IHD}	Minimum HIGH Dynamic Input Voltage Level (Note 4)(Note 7)	5.5	1.6	2.0	2.0		V	
V _{ILD}	Maximum LOW Dynamic Input Voltage Level (Note 4)(Note 7)	5.5	1.4	0.8	0.8		V	
<p>Note 4: Worst case package.</p> <p>Note 5: Maximum number of outputs that can switch simultaneously is n. (n-1) outputs are switched LOW and one output held LOW.</p> <p>Note 6: Maximum number of outputs that can switch simultaneously is n. (n-1) outputs are switched HIGH and one output held HIGH.</p> <p>Note 7: Maximum number of data inputs (n) switching. (n-1) input switching 0V to 3V. Input under test switching 3V to threshold (V_{ILD}).</p>								
AC Electrical Characteristics								
Normal Operation								
Symbol	Parameter	V _{CC} (V) (Note 8)	T _A = +25°C C _L = 50 pF			T _A = -40°C to +85°C C _L = 50 pF		Units
			Min	Typ	Max	Min	Max	
t _{PLH}	Propagation Delay A to B, B to A	5.0	1.6		7.9	1.6	8.5	ns
t _{PHL}			1.6		7.9	1.6	8.8	
t _{PLZ}	Disable Time	5.0	1.2		8.6	1.2	9.5	ns
t _{PHZ}			1.2		8.5	1.2	9.0	
t _{PZL}	Enable Time	5.0	1.6		11.0	1.6	12.0	ns
t _{PZH}			1.6		8.5	1.6	9.5	
<p>Note 8: Voltage Range 5.0 is 5.0V ± 0.5V.</p> <p>Note: All Input Timing Delays involving TCK are measured from the rising edge of TCK.</p>								

AC Electrical Characteristics								
Scan Test Operation								
Symbol	Parameter	V _{CC} (V) (Note 9)	T _A = +25°C C _L = 50 pF			T _A = -40°C to +85°C C _L = 50 pF		Units
			Min	Typ	Max	Min	Max	
t _{PLH} , t _{PHL}	Propagation Delay TCK to TDO	5.0	2.8		13.2	2.8	14.5	ns
t _{PLZ} , t _{PHZ}	Disable Time TCK to TDO	5.0	2.0		11.5	2.0	11.9	ns
t _{PZL} , t _{PZH}	Enable Time TCK to TDO	5.0	2.4		14.5	2.4	15.8	ns
t _{PLH} , t _{PHL}	Propagation Delay TCK to Data Out During Update-DR State	5.0	4.0		18.0	4.0	19.8	ns
t _{PLH} , t _{PHL}	Propagation Delay TCK to Data Out During Update-IR State	5.0	4.0		18.6	4.0	20.2	ns
t _{PLH} , t _{PHL}	Propagation Delay TCK to Data Out During Test Logic Reset State	5.0	4.4		19.9	4.4	21.5	ns
t _{PZL} , t _{PZH}	Propagation Delay TCK to Data Out During Update-DR State	5.0	3.2		16.4	3.2	18.2	ns
t _{PZL} , t _{PZH}	Propagation Delay TCK to Data Out During Update-IR State	5.0	2.8		18.0	2.8	19.3	ns
t _{PZL} , t _{PZH}	Propagation Delay TCK to Data Out During Test Logic Reset State	5.0	2.8		18.4	2.8	20.0	ns
t _{PZL} , t _{PZH}	Propagation Delay TCK to Data Out During Update-DR State	5.0	4.0		18.9	4.0	20.9	ns
t _{PZL} , t _{PZH}	Propagation Delay TCK to Data Out During Update-IR State	5.0	3.2		19.9	3.2	21.7	ns
t _{PZL} , t _{PZH}	Propagation Delay TCK to Data Out During Test Logic Reset State	5.0	3.6		21.3	3.6	23.3	ns

Note 9: Voltage Range 5.0 is 5.0V ± 0.5V.

Note: All Input Timing Delays involving TCK are measured from the rising edge of TCK.

Note: All Propagation Delays involving TCK are measured from the falling edge of TCK.

AC Operating Requirements					
Scan Test Operation					
Symbol	Parameter	V _{CC} (V) (Note 10)	T _A = +25°C	T _A = -40°C to +85°C	Units
			C _L = 50 pF	C _L = 50 pF	
			Guaranteed Minimum		
t _S	Setup Time, H or L Data to TCK (Note 11)	5.0	0.0	0.0	ns
t _H	Hold Time, H or L TCK to Data (Note 11)	5.0	6.5	6.5	ns
t _S	Setup Time, H or L $\overline{G1}$, $\overline{G2}$ to TCK (Note 12)	5.0	0.0	0.0	ns
t _H	Hold Time, H or L TCK to $\overline{G1}$, $\overline{G2}$ (Note 12)	5.0	4.0	4.0	ns
t _S	Setup Time, H or L DIR1, DIR2 to TCK (Note 13)	5.0	0.0	0.0	ns
t _H	Hold Time, H or L TCK to DIR1, DIR2 (Note 13)	5.0	4.0	4.0	ns
t _S	Setup Time, H or L Internal AOE _n , BOE _n to TCK (Note 14)	5.0	1.0	1.0	ns
t _H	Hold Time, H or L TCK to Internal AOE _n , BOE _n (Note 14)	5.0	4.0	4.0	ns
t _S	Setup Time, H or L TMS to TCK	5.0	7.0	7.0	ns
t _H	Hold Time, H or L TCK to TMS	5.0	2.0	2.0	ns
t _S	Setup Time, H or L TDI to TCK	5.0	1.0	1.0	ns
t _H	Hold Time, H or L TCK to TDI	5.0	3.5	3.5	ns
t _W	Pulse Width	5.0			
			H	15.0	15.0
			L	5.0	5.0
f _{MAX}	Maximum TCK Clock Frequency	5.0	25	25	MHz
T _{PU}	Wait Time, Power Up to TCK	5.0	100	100	ns
T _{DN}	Power Down Delay	0.0	100	100	ms

Note 10: Voltage Range 5.0 is 5.0V ± 0.5V.

Note 11: Timing pertains to the TYPE1 BSR and TYPE2 BSR after the buffer (BSR 0–8, 9–17, 18–26, 27–35, 36–44, 45–53, 54–62, 63–71).

Note 12: Timing pertains to BSR 74 and 78 only.

Note 13: Timing pertains to BSR 75 and 79 only.

Note 14: Timing pertains to BSR 72, 73, 76 and 77 only.

Note: All Input Timing Delays involving TCK are measured from the rising edge of TCK.

Extended AC Electrical Characteristics

Symbol	Parameter	$T_A = +25^\circ\text{C}$, $V_{CC} = 5.0\text{V}$ $C_L = 50\text{ pF}$ 18 Outputs Switching (Note 15)			$T_A = -40^\circ\text{C to } +85^\circ\text{C}$ $V_{CC} = 5.0\text{V} \pm 0.5\text{V}$ $C_L = 250\text{ pF}$ (Note 16)		Units
		Min	Typ	Max	Min	Max	
t_{PLH} , t_{PHL}	Propagation Delay Data to Output	2.5		10.5	3.5	12.0	ns
		2.5		10.5	3.5	13.5	
t_{PZH} , t_{PZL}	Output Enable Time	2.5		10.5	(Note 17)		ns
		2.5		13.5			
t_{PHZ} , t_{PLZ}	Output Disable Time	2.0		9.5	(Note 18)		ns
		2.0		10.0			
t_{OSHL} (Note 19)	Pin to Pin Skew HL Data to Output		0.5	1.0	1.0		ns
t_{OSLH} (Note 19)	Pin to Pin Skew LH data to Output		0.5	1.0	1.0		

Note 15: This specification is guaranteed but not tested. The limits apply to propagation delays for all paths described switching in phase (i.e., all LOW-to-HIGH, HIGH-to-LOW, etc.)

Note 16: This specification is guaranteed but not tested. The limits represent propagation delays with 250 pF load capacitors in place of the 50 pF load capacitors in the standard AC load. This specification pertains to single output switching only.

Note 17: 3-STATE delays are load dominated and have been excluded from the datasheet.

Note 18: The Output Disable Time is dominated by the RC network (500Ω, 250 pF) on the output and has been excluded from the datasheet.

Note 19: Skew is defined as the absolute value of the difference between the actual propagation delays for any two separate outputs of the same device. The specification applies to any outputs switching HIGH-to-LOW (t_{OSHL}), LOW-to-HIGH (t_{OSLH}), or any combination switching LOW-to-HIGH and/or HIGH-to-LOW.

Capacitance

Symbol	Parameter	Typ	Units	Conditions
C_{IN}	Input Pin Capacitance	4	pF	$V_{CC} = 5.0\text{V}$
C_{IO}	Input/Output Capacitance	20	pF	$V_{CC} = 5.0\text{V}$
C_{PD}	Power Dissipation Capacitance	41	pF	$V_{CC} = 5.0\text{V}$

Physical Dimensions inches (millimeters) unless otherwise noted

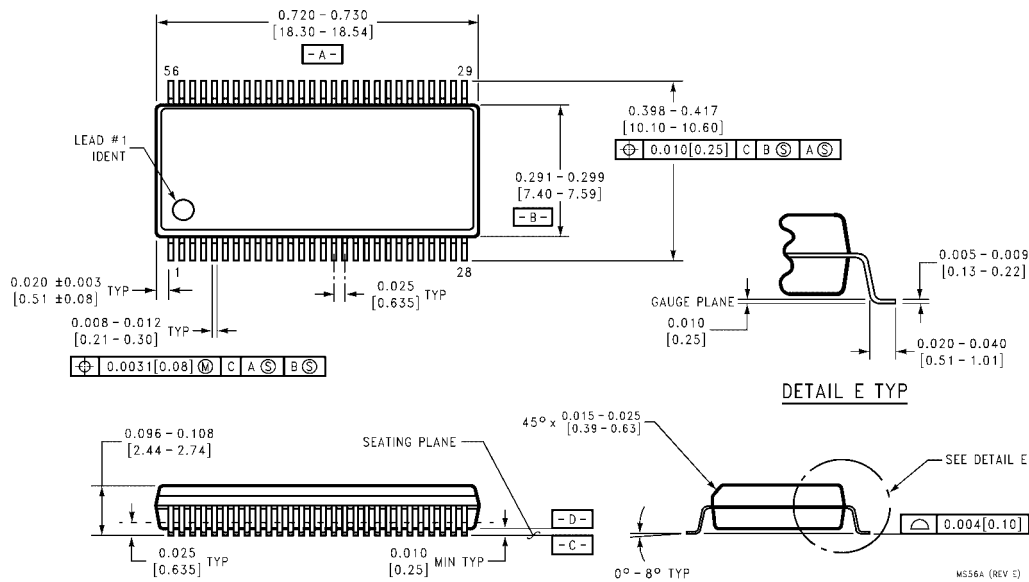

**56-Lead Shrink Small Outline Package (SSOP), JEDEC MO-118, 0.300 Wide
Package Number MS56A**

Fairchild does not assume any responsibility for use of any circuitry described, no circuit patent licenses are implied and Fairchild reserves the right at any time without notice to change said circuitry and specifications.

LIFE SUPPORT POLICY

FAIRCHILD'S PRODUCTS ARE NOT AUTHORIZED FOR USE AS CRITICAL COMPONENTS IN LIFE SUPPORT DEVICES OR SYSTEMS WITHOUT THE EXPRESS WRITTEN APPROVAL OF THE PRESIDENT OF FAIRCHILD SEMICONDUCTOR CORPORATION. As used herein:

1. Life support devices or systems are devices or systems which, (a) are intended for surgical implant into the body, or (b) support or sustain life, and (c) whose failure to perform when properly used in accordance with instructions for use provided in the labeling, can be reasonably expected to result in a significant injury to the user.
2. A critical component in any component of a life support device or system whose failure to perform can be reasonably expected to cause the failure of the life support device or system, or to affect its safety or effectiveness.

www.fairchildsemi.com