

# PMH Panel Mount Power Supply

## 24V 150W 1 Phase / PMH-24V150WCL□



# PMH

### Highlights & Features

- Household appliance approvals for pollution degree 3 to IEC/EN 60335-1, IEC/EN 61558-1 and IEC/EN 61558-2-16
- Universal AC input voltage
- Withstand line input voltage surge 300Vac up to 7 seconds
- Full power from -25°C to +50°C operation @ 5000m or 16400 ft. altitude
- Full corrosion resistant aluminium casing
- No load input power consumption < 0.3W @ 115Vac
- Low earth leakage current < 0.75mA
- Versatile connector options available: IP20, Front Face and Harness connectors

### Safety Standards



CB Certified for worldwide use

**Model Number:** PMH-24V150WCL□  
**Unit Weight:** 0.41 kg (0.90 lb)  
**Dimensions (L x W x D):** 159 x 97 x 30 mm  
 (6.26 x 3.82 x 1.18 inch)

### General Description

The PMH-24V150WCL□ offers universal input from 85Vac to 264Vac with nominal output voltage of 24V. The highly efficient convection cooling construction can operate from -30°C to 70°C. The single output is specifically designed with compact and competitively priced for household electrical appliances safety approvals to pollution degree 3 as well as including IEC/EN 60335-1, IEC/EN 61558-2-16, IEC/EN/UL 60950-1. In addition, the product meets the EMC approvals to EN 55014-1 / EN 55014-2 for household appliances and EN 61000-6-2 / EN 61000-6-3 for industrial and residential environment without extra EMI filter required and comes with several connector options consisting of Terminal Block, IP20, Front Face and Harness connectors.

### Model Information

PMH Panel Mount Power Supply

Model Number	Input Voltage Range	Rated Output Voltage	Rated Output Current
PMH-24V150WCL□	85-264Vac (120-375Vdc)	24Vdc	6.5A

### Model Numbering

PM	H –	24V	150W	C	L	□
Panel Mount	Product Type H – Household Series	Output Voltage	Output Power	Package Type C – Enclosed	L – Low Profile	Connector Type S – Terminal Block U – IP20 Connector* V – Front Face* T – Harness*

\*Options

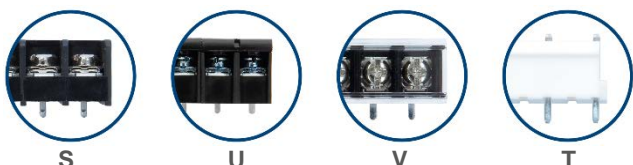

# PMH Panel Mount Power Supply

## 24V 150W 1 Phase / PMH-24V150WCL□

### Specifications

#### Input Ratings / Characteristics

Nominal Input Voltage	100-240Vac	
Input Voltage Range*	85-264Vac	
Nominal Input Frequency	50-60Hz	
Input Frequency Range	47-63Hz	
Nominal DC Input Voltage	125-250Vdc	
DC Input Voltage Range**	120-375Vdc	
Input Current	< 2.80A @ 115Vac, < 1.60A @ 230Vac	
Efficiency at 100% Load	> 87.0% @ 115Vac, > 89.0% @ 230Vac	
Max Power Dissipation	No Load	< 0.3W @ 115Vac, < 0.5W @ 230Vac
	100% Load	< 23W @ 115Vac, < 19.5W @ 230Vac
Max Inrush Current (Cold Start)	< 40A @ 115Vac, < 80A @ 230Vac	
Leakage Current	< 0.75mA @ 240Vac	

\*For power de-rating at 85-100Vac, see power de-rating on page 3.

\*\*Fulfills test conditions for DC input. Safety approval for DC input can be obtained upon request.

#### Output Ratings / Characteristics\*\*\*

Nominal Output Voltage	24Vdc
Factory Set Point Tolerance	24Vdc $\pm$ 2%
Output Voltage Adjustment Range	24-28Vdc
Output Current	0-6.5A (156W max.)
Output Power	156W
Line Regulation	< 0.5% (@ 100-264Vac input, 100% load)
Load Regulation	< 0.5% (@ 100-264Vac input, 0-100% load)
PARD**** (20MHz)	< 200mVpp
Rise Time	< 100ms @ nominal input (100% load)
Start-up Time	< 2500ms @ 115Vac & 230Vac (100% load)
Hold-up Time	> 10ms @ 115Vac, > 50ms @ 230Vac (100% load)
Dynamic Response (Overshoot & Undershoot O/P Voltage)	$\pm$ 5% @ 100-264Vac input, 0-50%, 0-100%, 50-100% load (Slew Rate: 0.1A/ $\mu$ S, 50% duty cycle @ 5Hz to 1kHz)
Start-up with Capacitive Loads	3,000 $\mu$ F Max

\*\*\*For power de-rating from < -25°C to -30°C, and 50°C to 70°C, see power de-rating on page 3.

\*\*\*\*PARD is measured with an AC coupling mode, 5cm wires, and in parallel with 0.1 $\mu$ F ceramic capacitor & 47 $\mu$ F electrolytic capacitor.

# PMH Panel Mount Power Supply

## 24V 150W 1 Phase / PMH-24V150WCL□

### Mechanical

Case Chassis / Cover	Aluminium	
Dimensions (L x W x D)	159 x 97 x 30 mm (6.26 x 3.82 x 1.18 inch)	
Unit Weight	0.41 kg (0.90 lb)	
Indicator	Green LED (DC OK)	
Cooling System	Convection	
Terminal	PMH-24V150WCLS	M3.5 x 7 Pins (Rated 300V/15A)
	PMH-24V150WCLU	M3.5 x 7 Pins (Rated 300V/20A)
	PMH-24V150WCLV	M3.5 x 7 Pins (Rated 300V/20A)
	PMH-24V150WCLT	<b>Power Supply Header</b> Input: B3P(6-2.3.5)-VH(LF)(SN) Output: B4P7-VH(LF)(SN)
		<b>Mating Connector</b> Input: VHR-6N Output: VHR-7N
Wire	PMH-24V150WCLS	AWG 20-14
	PMH-24V150WCLU	AWG 20-12
	PMH-24V150WCLV	AWG 20-12
	PMH-24V150WCLT	AWG 22-18
Noise (1 Meter from power supply)	Sound Pressure Level (SPL) < 25dBA	

### Environment

Surrounding Air Temperature	Operating	-30°C to +70°C
	Storage	-40°C to +85°C
Power De-rating	Temperature	< -25°C de-rate power by 5.0% / °C > 50°C de-rate power by 2.5% / °C
	Input Voltage	< 100Vac de-rate power by 1.33%/°C
Operating Humidity	5 to 95% RH (Non-Condensing)	
Operating Altitude	0 to 5,000 Meters (16,400 ft.)	
Shock Test	Non-Operating	IEC 60068-2-27, 30G (300m/S <sup>2</sup> ) for a duration of 18ms, 3 times per direction, 9 times in total
Vibration	Non-Operating	IEC 60068-2-6, 10Hz to 150Hz @ 50m/S <sup>2</sup> (5G peak); displacement of 0.35mm; 20 min per axis for all X, Y, Z direction
Bump	Non-Operating	IEC 60068-2-29, 10G (100m/S <sup>2</sup> ) for a duration of 11ms, 1000 times per direction, 6000 times in total
Over Voltage Category	II	
Pollution Degree	3	

# PMH Panel Mount Power Supply

## 24V 150W 1 Phase / PMH-24V150WCL□

### Protections

Overvoltage	< 35V, SELV output, Latch Mode
Overload / Overcurrent	110~160% of rated load current, Hiccup Mode, Non-Latching (Auto recovery)
Over Temperature	< 75°C Surrounding Air Temperature @ 100% load, Latch Mode
Short Circuit	Hiccup Mode, Non-Latching (Auto-recovery when the fault is removed).
Internal Fuse at L pin	T 4AH
Degree of Protection	IP20 (PMH-24V150WCLU)
Protection Against Shock	Class I with PE* connection

\*PE: Primary Earth

### Reliability Data

MTBF	> 700,000 hrs. as per Telcordia SR-332 I/P: 115Vac, O/P: 100% load, Ta: 25°C
Expected Cap Life Time	10 years (115Vac & 230Vac, 50% load @ 40°C)

### Safety Standards / Directives

Safety Entry Low Voltage		SELV (EN 60950-1)
Electrical Safety	SIQ Bauart	EN 60950-1, EN 60335-1, EN 61558-1, EN 61558-2-16
	UL/cUL recognized	UL 60950-1 and CSA C22.2 No. 60950-1 (File No. E191395)
	CB scheme	IEC 60950-1, IEC 60335-1, IEC 61558-1, IEC 61558-2-16
CE		In conformance with EMC Directive 2014/30/EU and Low Voltage Directive 2014/35/EU
Material and Parts		RoHS Directive 2011/65/EU Compliant
Galvanic Isolation	Input to Output	4.0KVac
	Input to Ground	2.0KVac
	Output to Ground	1.1KVdc

# PMH Panel Mount Power Supply

## 24V 150W 1 Phase / PMH-24V150WCL□

## EMC

Emissions (CE & RE)		EN 55011, CISPR 32, EN 55032, FCC Title 47: Class B, EN 55014-1, EN 61000-6-3	
Component Power Supply for General Use		EN 61204-3	
Immunity		EN 55024, EN 61000-6-2, EN 55014-2	
Electrostatic Discharge	IEC 61000-4-2	Level 3 Criteria A <sup>1)</sup> Air Discharge: 8kV Contact Discharge: 6kV	
Radiated Field	IEC 61000-4-3	Level 3 Criteria A <sup>1)</sup> 80MHz-1GHz, 10V/M with 1kHz tone / 80% modulation 1.4GHz-2GHz, 3V/M with 1kHz tone / 80% modulation 2GHz-2.7GHz, 1V/M with 1kHz tone / 80% modulation	
Electrical Fast Transient / Burst	IEC 61000-4-4	Level 3 Criteria A <sup>1)</sup> 2kV	
Surge	IEC 61000-4-5	Level 4 Criteria A <sup>1)</sup> Common Mode <sup>3)</sup> : 4kV Differential Mode <sup>4)</sup> : 2kV	
Conducted	IEC 61000-4-6	Level 3 Criteria A <sup>1)</sup> 150kHz-80MHz, 10Vrms	
Power Frequency Magnetic Fields	IEC 61000-4-8	Criteria A <sup>1)</sup> 30A/Meter	
Voltage Dips and Interruptions	IEC 61000-4-11	0% of 100Vac, 20ms 40% of 100Vac, 200ms 70% of 100Vac, 500ms 0% of 100Vac, 5000ms 0% of 240Vac, 20ms 40% of 240Vac, 200ms 70% of 240Vac, 500ms 0% of 240Vac, 5000ms	Criteria A <sup>1)</sup> Criteria A <sup>1)</sup> Criteria A <sup>1)</sup> Criteria B <sup>2)</sup> Criteria A <sup>1)</sup> Criteria A <sup>1)</sup> Criteria A <sup>1)</sup> Criteria B <sup>2)</sup>
Low Energy Pulse Test (Ring Wave)	IEC 61000-4-12	Level 3 Criteria A <sup>1)</sup> Common Mode <sup>3)</sup> : 2kV Differential Mode <sup>4)</sup> : 1kV	
Harmonic Current Emission		IEC/EN 61000-3-2, Class A ( $\leq 70\%$ Load)	
Voltage Fluctuation and Flicker		IEC/EN 61000-3-3	

1) Criteria A: Normal performance within the specification limits

2) Criteria B: Temporary degradation or loss of function which is self-recoverable

3) Asymmetrical: Common mode (Line to earth)

4) Symmetrical: Differential mode (Line to line)

# PMH Panel Mount Power Supply

## 24V 150W 1 Phase / PMH-24V150WCL□

### Block Diagram

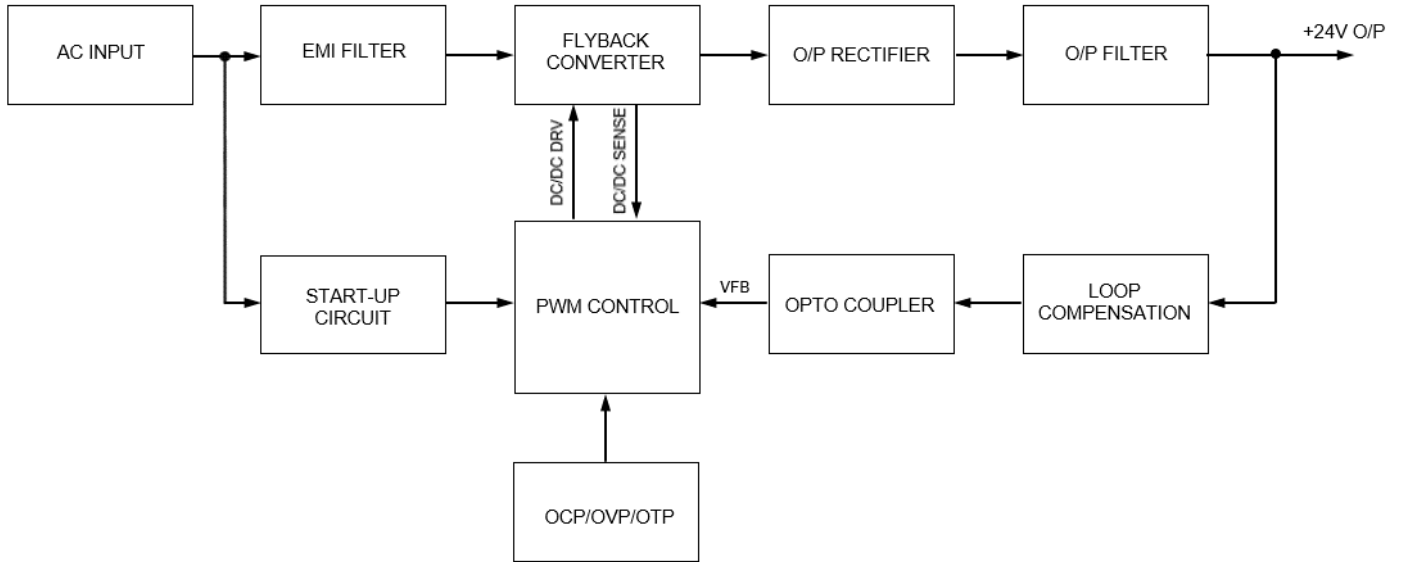

### Device Descriptions

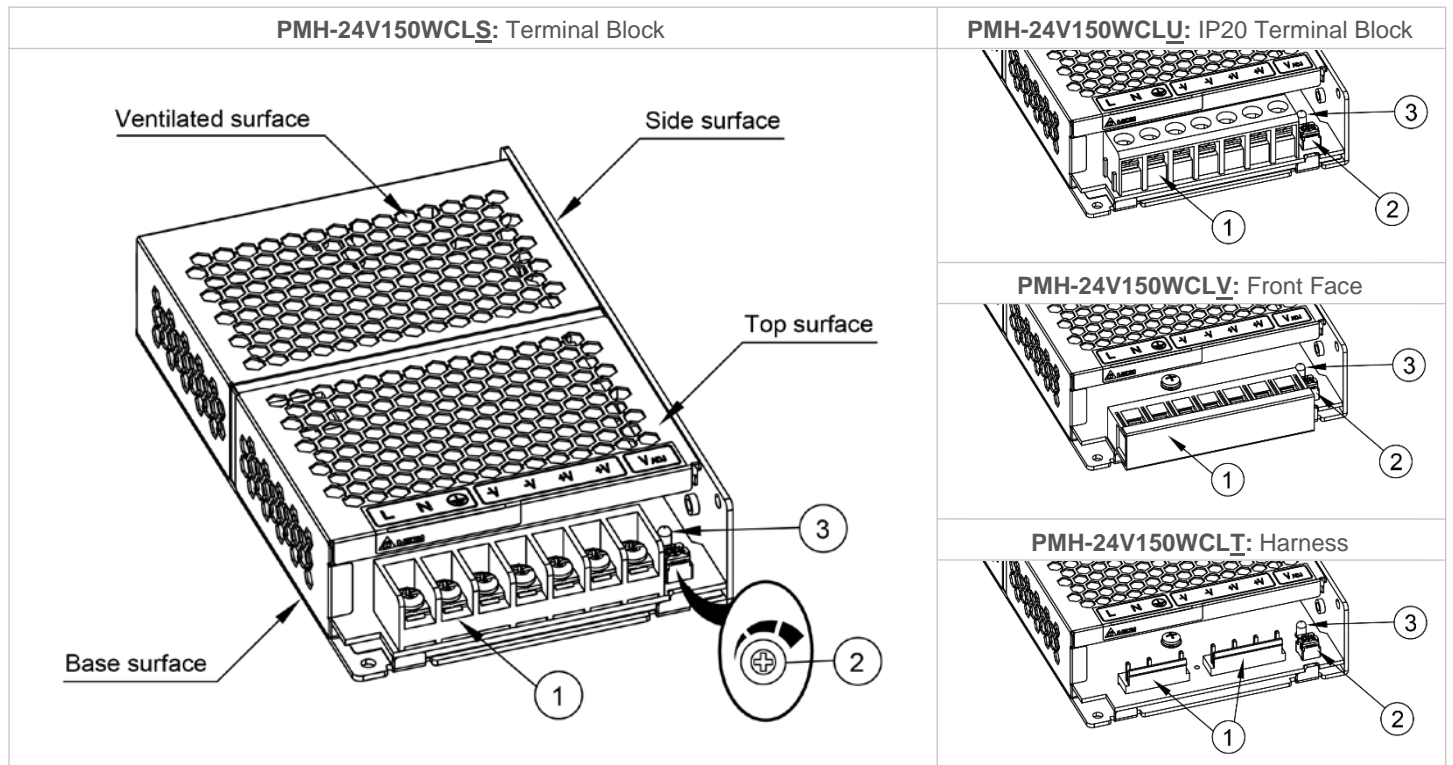

- 1) Input & Output terminal block connector
- 2) DC voltage adjustment potentiometer (24V – 28V)
- 3) DC OK control LED (Green)

Connector Type	Output isolated to PE
Terminal Block	S
IP20 Connector	U
Front Face	V
Harness	T

# PMH Panel Mount Power Supply

## 24V 150W 1 Phase / PMH-24V150WCL□

### Dimensions

L x W x D: 159 x 97 x 30 mm (6.26 x 3.82 x 1.18 inch) (PMH-24V150WCL□: Terminal Block)

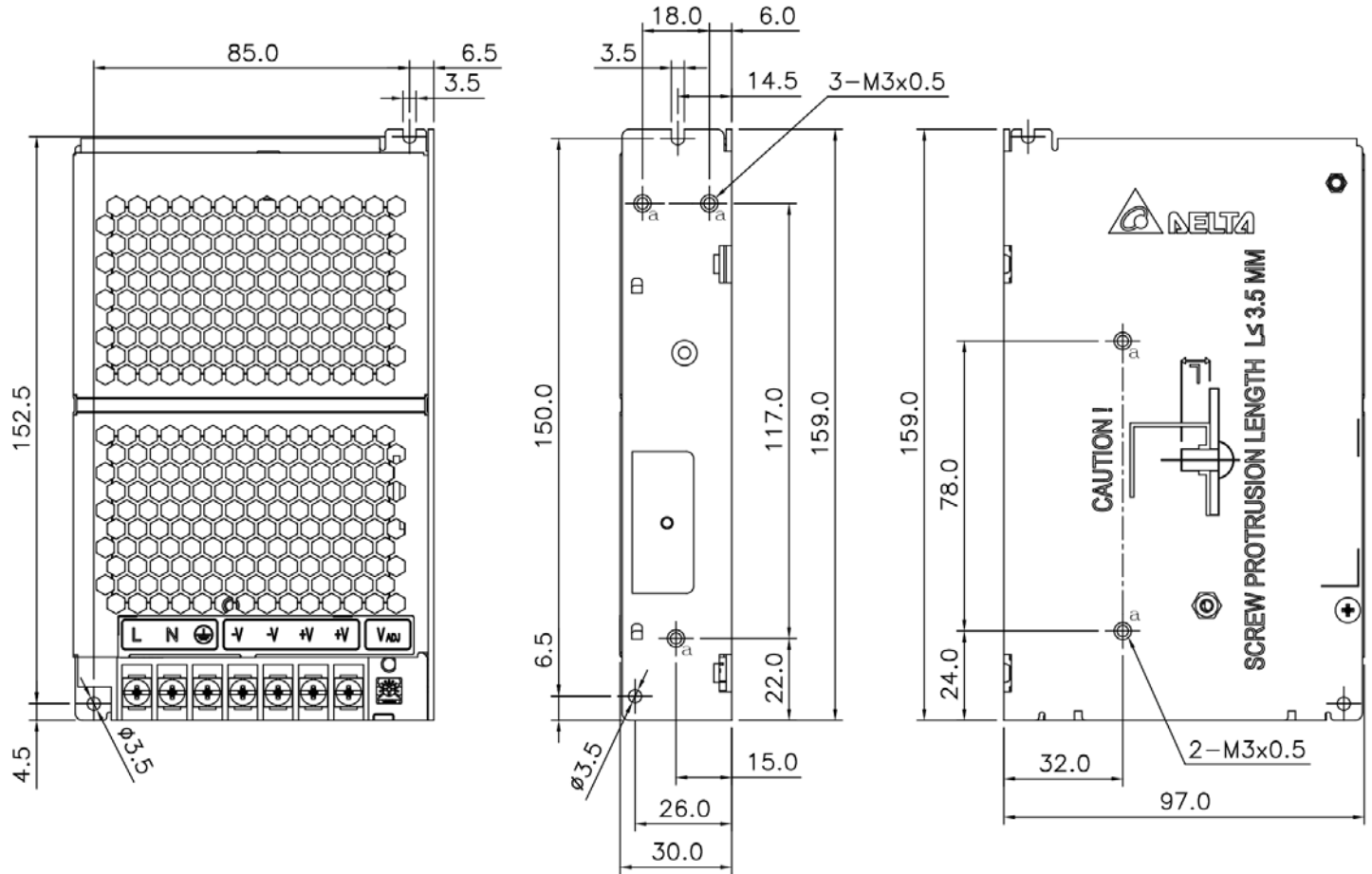

# PMH Panel Mount Power Supply

## 24V 150W 1 Phase / PMH-24V150WCL□

### Engineering Data

#### Output Load De-rating VS Surrounding Air Temperature

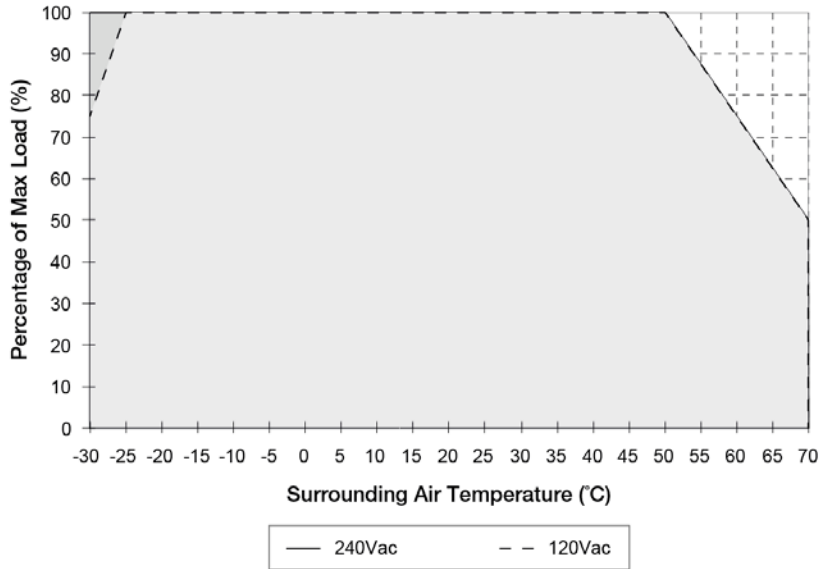
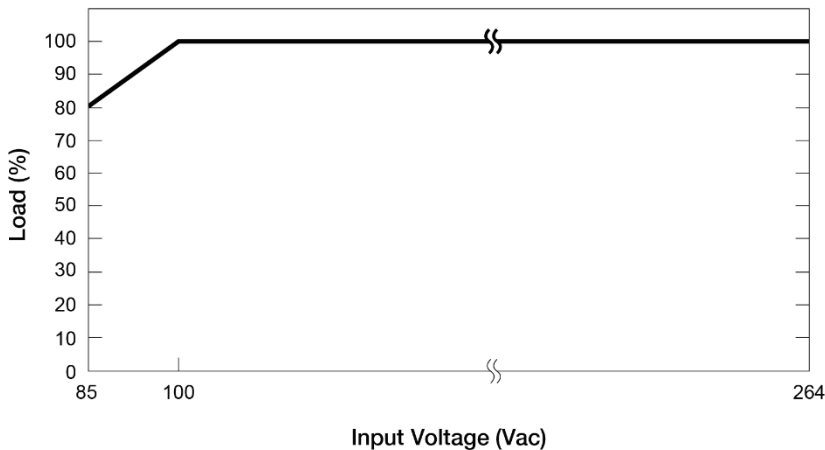

**Fig. 1 De-rating for Vertical and Horizontal Mounting Orientation**  
**120Vac**  
 < -25°C de-rate power by 5.0% / °C  
**120Vac and 240Vac**  
 > 50°C de-rate power by 2.5% / °C

#### Note

1. Power supply components may degrade, or be damaged, when the power supply is continuously used outside the shaded region, refer to the graph shown in Fig. 1.
2. If the output capacity is not reduced when surrounding air temperature exceeds its specification as defined on Page 3 under "Environment", the device will run into Over Temperature Protection. When activated, power supply will go into Latch mode, until the surrounding air temperature is lowered or the load is reduced as far as necessary to keep the device in working condition, and require removal/re-application of input AC voltage in order to restart.
3. In order for the device to function in the manner intended, it is also necessary to keep a safety distance as recommended in the safety instructions while the device is in operation.
4. Depending on the surrounding air temperature and output load delivered by the power supply, the device can be very hot!
5. If the device has to be mounted in any other orientation, please contact [info@deltapsu.com](mailto:info@deltapsu.com) for more details.

#### Output Load De-rating VS Input Voltage



- No output power de-rating for the input voltage from 100Vac to 264Vac

# PMH Panel Mount Power Supply

## 24V 150W 1 Phase / PMH-24V150WCL□

### Assembly & Installation

- Ⓐ Mounting holes for power supply assembly onto the mounting surface.  
The power supply shall be mounted on minimum 2 mounting holes using M3 screw minimum 5mm (0.20 inch) length.
- Ⓑ This surface belongs to customer's end system or panel where the power supply is mounted.
- Ⓒ Connector

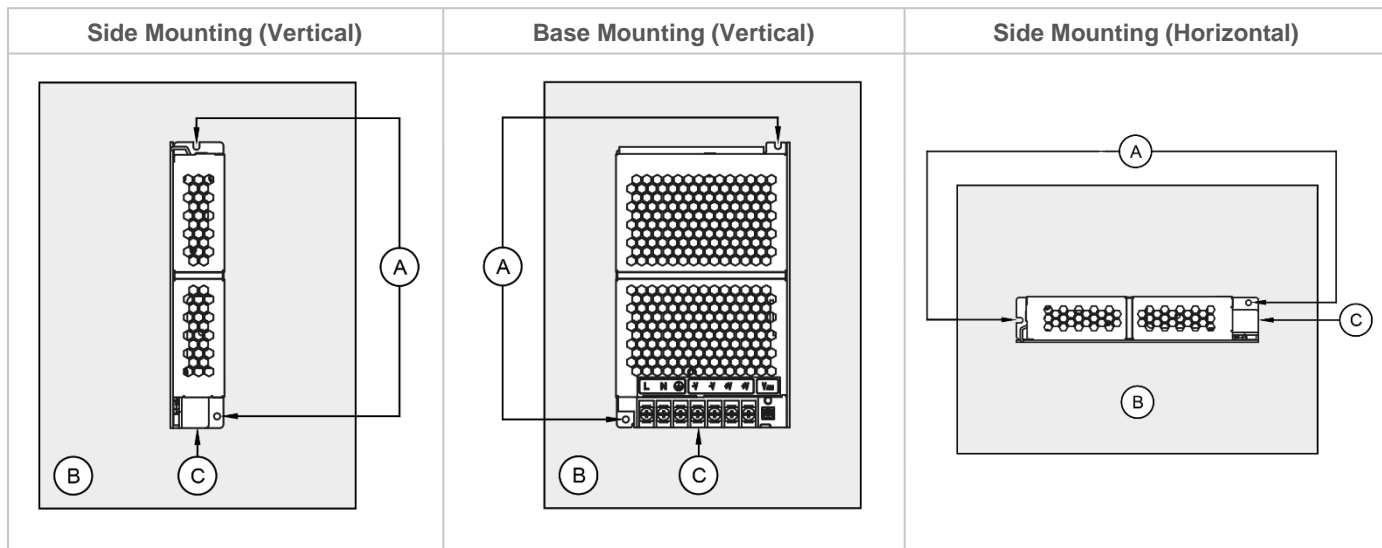

Fig. 2 Mounting Orientation

- Use flexible cable (stranded or solid) with the following sizes:

PMH-24V150WCL <u>S</u>	PMH-24V150WCL <u>U</u>	PMH-24V150WCL <u>V</u>	PMH-24V150WCL <u>T</u>
AWG 20-14	AWG 20-12	AWG 20-12	AWG 22-18

- The torque at the Connector shall not exceed 13Kgf.cm (11.23 lbf.in). The insulation stripping length should not exceed 0.275" or 7mm.
- Please refer the table below for the recommended mating connector, terminal and AWG wire size of **PMH-24V150WCLT**.

	Power Supply Header	Mating Connector	Terminal	AWG
<b>Input (JST)</b>	B3P(6-2.3.5)-VH(LF)(SN)	VHR-6N	SVH-21T-P1.1	22-18
<b>Output (JST)</b>	B4P7-VH(LF)(SN)	VHR-7N	SVH-21T-P1.1	22-18

# PMH Panel Mount Power Supply

## 24V 150W 1 Phase / PMH-24V150WCL□

### Installation of Mounting Accessories

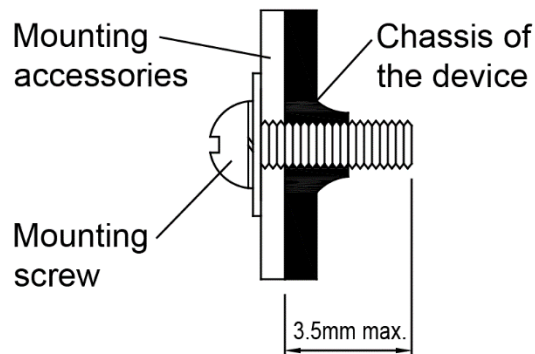

- Only use M3 screw  $\leq 3.5\text{mm}$  (0.14 inch) through the base mounting holes. This is to keep a safety distance between the screw and internal components.
- Recommended mounting tightening torque: 4~8Kgf.cm (3.47~6.94 lbf.in).

### Safety Instructions

- To ensure sufficient convection cooling, always maintain a safety distance of  $\geq 50\text{mm}$  (1.97 inch) from all ventilated surfaces while the device is in operation.
- The device is not recommended to be placed on surface with low thermal conductivity, such as plastics, for example.
- Note that the enclosure of the device can become very hot depending on the ambient temperature and load of the power supply. Do not touch the device while it is in operation or immediately after power is turned OFF. Risk of burning!
- Do not touch the terminals while power is being supplied. Risk of electric shock.
- Prevent any foreign metal, particles or conductors from entering the device through the openings during installation. It may cause: Electric shock; Safety Hazard; Fire; Product failure
- The appliance is not to be used by persons (including children) with reduced physical, sensory or mental capabilities, or lack of experience and knowledge, unless they have been given supervision or instruction.
- Warning: When connecting the device, secure Earth connection before connecting L and N. When disconnecting the device, remove L and N connections before removing the Earth connection.
- The device is earthed and must be inaccessible.

# PMH Panel Mount Power Supply

## 24V 150W 1 Phase / PMH-24V150WCL□

### Functions

- Graph illustrating the Start-up Time, Rise Time, and Hold-up Time

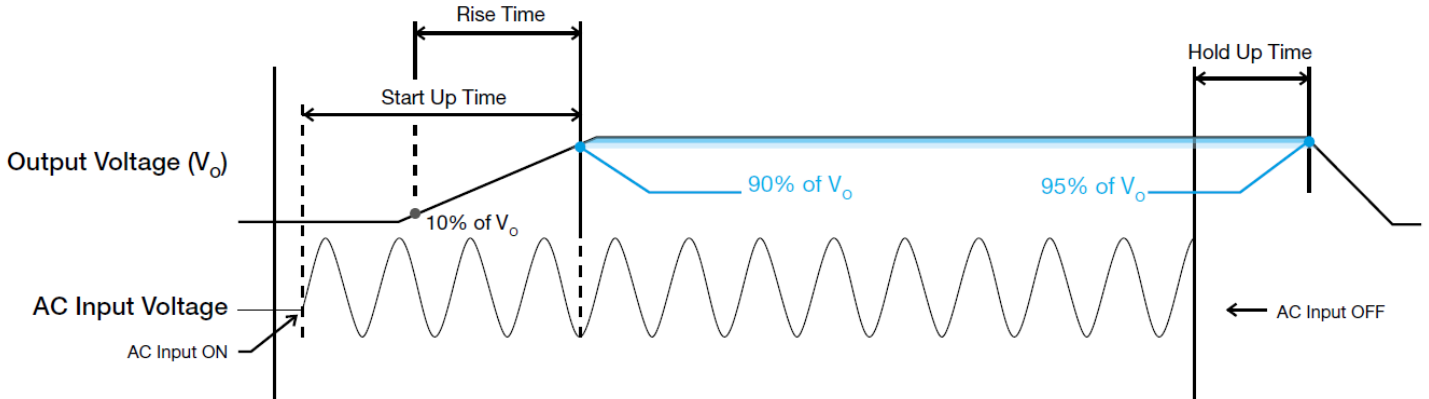

### Start-up Time

The time required for the output voltage to reach 90% of its final steady state set value, after the input voltage is applied.

### Rise Time

The time required for the output voltage to change from 10% to 90% of its final steady state set value.

### Hold-up Time

Time between the collapse of the AC input voltage, and the output falling to 95% of its steady state set value.

### Inrush Current

Inrush current is the peak, instantaneous, input current measured and, occurs when the input voltage is first applied. For AC input voltages, the maximum peak value of inrush current will occur during the first half cycle of the applied AC voltage. This peak value decreases exponentially during subsequent cycles of AC voltage.

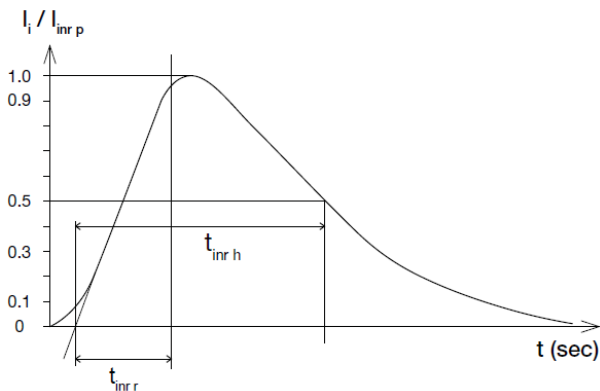

### Dynamic Response

The power supply output voltage will remain within  $\pm 5\%$  of its steady state value, when subjected to a dynamic load from 0% to 50%, 0 to 100% and 50% to 100% of its rated current.

- 50% duty cycle / 5Hz to 1kHz

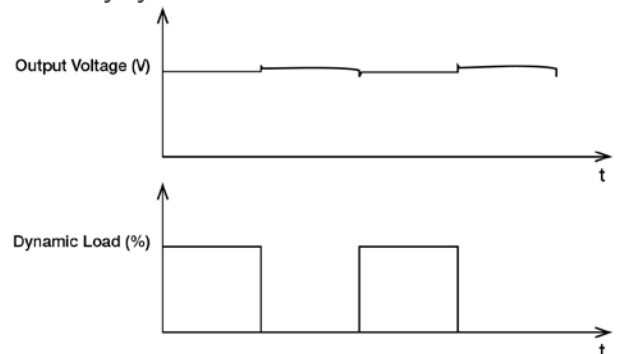

# PMH Panel Mount Power Supply

## 24V 150W 1 Phase / PMH-24V150WCL□

### Overload & Overcurrent Protections (Auto-Recovery)

The power supply's Overload (OLP) and Overcurrent (OCP) Protection will be activated when output current ( $I_o$ ) exceeds its specification as defined on Page 4 under "Protections". In such occurrence, the output voltage ( $V_o$ ) will start to droop and once the power supply has reached its maximum power limit, the protection is activated and the power supply will go into "Hiccup mode" (Auto-Recovery). The power supply will recover once the fault condition of the OLP and OCP is removed and  $I_o$  is back within the specifications.

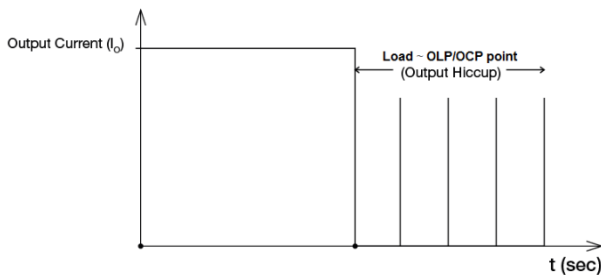

It is not recommended to prolong the duration of  $I_o$  when it is less than OLP/OCP point, but greater than 100%, since it may cause damage to the PSU.

### Overvoltage Protection (Latch Mode)

The power supply's overvoltage circuit will be activated when its internal feedback circuit fails. The output voltage shall not exceed its specifications defined on Page 4 under "Protections". Power supply will latch, and require removal/re-application of input AC voltage in order to restart.

**The power supply should be latch, and require removal/re-application of input AC voltage in order to restart.**

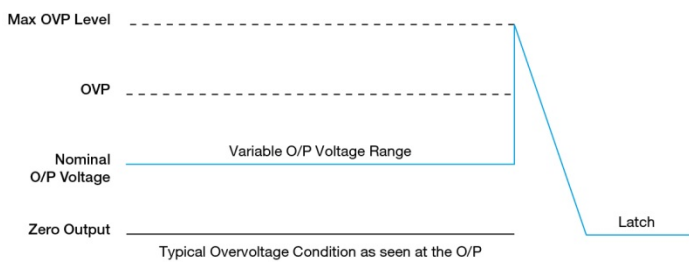

### External Input Protection Device

The unit is protected with internal fuse (not replaceable) at L pin and it has been tested and approved on 20A (UL) and 16A (IEC) branch circuits without additional protection device. An external protection device is only required if the supplying branch has an ampacity greater than above. Thus, if an external protective device is necessary, or, utilized, please refer a minimum value of 13A C-characteristic breaker should be used.

### Short Circuit Protection (Auto-Recovery)

The power supply's output OLP/OCP function also provides protection against short circuits. When a short circuit is applied, the output current will operate in "Hiccup mode", as shown in the illustration in the OLP/OCP section on this page. The power supply will return to normal operation after the short circuit is removed.

### Over Temperature Protection (Latch Mode)

As described in load de-rating section, the power supply also has Over Temperature Protection (OTP). In the event of a higher operating temperature at 100% load, the power supply will run into OTP when the operating temperature is beyond what is recommended in the de-rating graph. When activated, the output voltage will go into latch mode until the surrounding air temperature drops to its normal operating temperature or the load is reduced as recommended in the de-rating graph. Removal/re-application of input AC voltage will then be required in order to restart.

### Line Input Voltage Surge

The power supply is operating with 100% load, the line input voltage is switched to the voltage surge from 240Vac to 300Vac (50Hz) and back to 240Vac with a 10% duty cycle. The unit shall survive repeated applications of the line voltage surges with no component damage. The power supply's output voltages shall remain within the specified range during and subsequent to these line voltage surges.

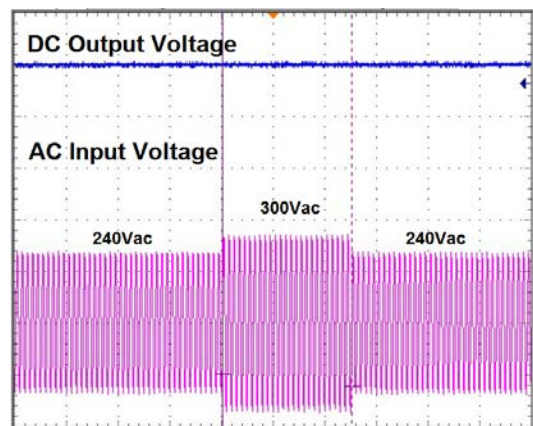

# PMH Panel Mount Power Supply

## 24V 150W 1 Phase / PMH-24V150WCL□

### Operating Mode

#### ■ Redundant Operation

In order to ensure proper redundant operation for the power supply units (PSUs), the output voltage difference between the two units must be kept at 0.45~0.50V for these 24V supplies. Follow simple steps given below to set them up for the redundant operation:

##### Step 1.

Measure output voltage of PSU 1 and PSU 2. If PSU 1 is the master unit, then  $V_o$  of PSU 1 must be higher than PSU 2. In order to set the output voltage, individually connect each power supply to 50% of rated load at any line voltage from 85-264Vac, and set the PSU 1 and PSU 2 output voltage.

##### Step 2.

Connect the power supply units PSU 1 and PSU 2 to Vin 1 & Vin 2, respectively, of the DRR-20N (or 20A) module shown on the right of above diagram.

##### Step 3.

Connect the system load to  $V_{out}$ . Please note that output voltage  $V_{out}$  from DRR module will be =  $V_o$  (output voltage of power supply) –  $V_{drop}^*$  (in DRR module).

\* $V_{drop}$  will vary from 0.60V to 0.90V (Typical 0.65V) depending on the load current and surrounding air temperature.

#### ■ Parallel Operation

The power supply units (PSUs) can also be used for parallel operation in order to increase the output power. The difference in output voltage between the two units must be kept to within 25mV of each other. This difference must be verified with the same output load connected independently to each unit.

Parameters such as EMI, inrush current, leakage current, PARD, start up time will be different from those on the datasheet, when two units are connected in parallel. The user will need to verify that any differences will still allow the two power supplies connected in parallel will work properly in their product/application.

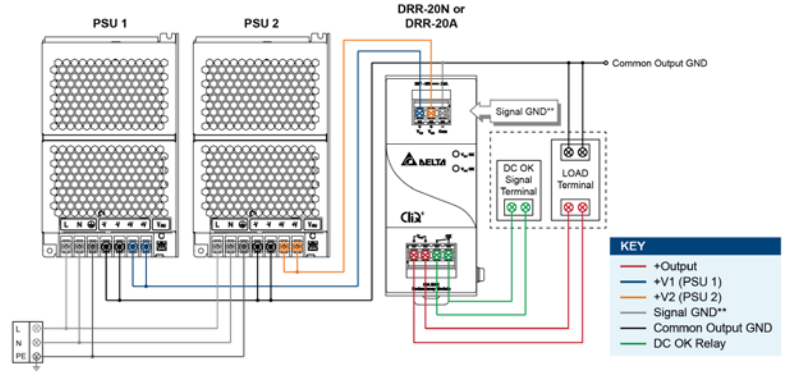

\*\*The Signal GND in the DRR module is for the built-in LED and DC OK signals. The Output GND terminals from the two PSU's do not need to be connected to the Signal GND terminal.

Fig. 3 Redundant Operation Connection Diagram

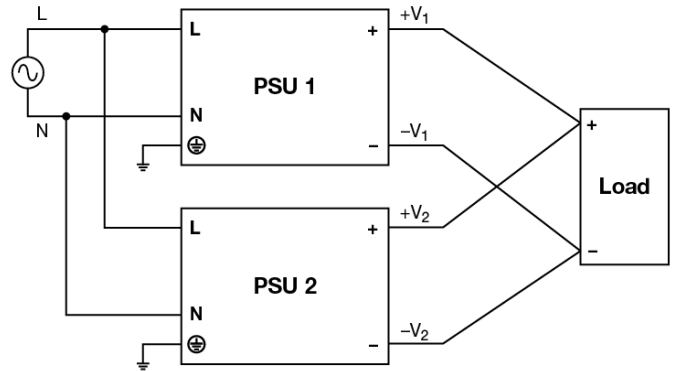

Fig. 4 Parallel Operation Connection Diagram

# PMH Panel Mount Power Supply

## 24V 150W 1 Phase / PMH-24V150WCL□

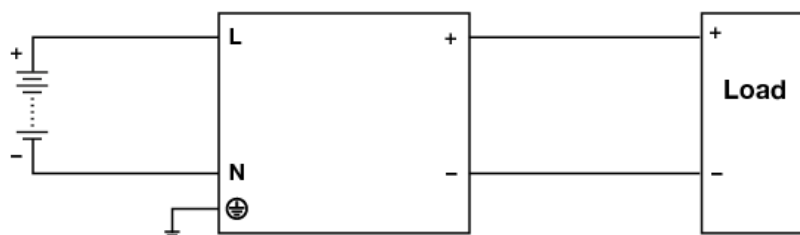

Fig. 5 DC Input Operation Connection Diagram

### ■ DC Input Operation

**Step 1.**  
Use a battery or similar DC source.

**Step 2.**  
Connect +pole to L and -pole to N.

**Step 3.**  
Connect the PE terminal to an earth wire or to the machine ground.

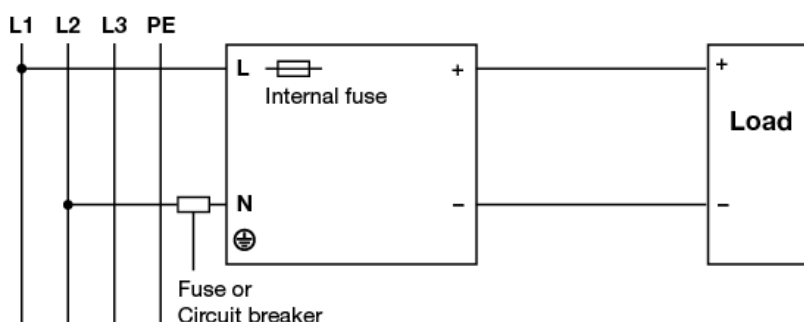

Fig. 6 2 of 3 Phase System Input Operation Connection Diagram

### ■ 2 of 3 Phase System Input Operation

Delta's PMH can use on 2 of 3 phase system. Please refer to the following step.

**Step 1.**  
The input voltage applied from Line to Neutral is below the maximum rated input. The input voltage shall be below 240Vac +10%.

**Step 2.**  
The external protector is needed on N (Neutral) input line to secure a safety. N line does not have internal fuse protection. An appropriate fuse or circuit breaker should be connected in series with N input line connection like the following.

# PMH Panel Mount Power Supply

## 24V 150W 1 Phase / PMH-24V150WCL□

### Others

Delta RoHS Compliant



#### Restriction of the usage of hazardous substances

The European directive 2011/65/EU limits the maximum impurity level of homogeneous materials such as lead, mercury, cadmium, chrome, polybrominated flame retardants PBB and PBDE for the use in electrical and electronic equipment. RoHS is the abbreviation for "Restriction of the use of certain hazardous substances in electrical and electronic equipment".

This product conforms to this standard.

### PFC – Norm EN 61000-3-2

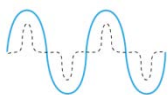

#### Line Current Harmonic content

Typically, the input current waveform is not sinusoidal due to the periodical peak charging of the input capacitor. In industrial environment, complying with EN 61000-3-2 is only necessary under special conditions. Complying to this standard can have some technical drawbacks, such as lower efficiency as well as some commercial aspects such as higher purchasing costs. Frequently, the user does not profit from fulfilling this standard, therefore, it is important to know whether it is mandatory to meet this standard for a specific application.