

2N3418(S) - 2N3421(S) Series



NPN Medium Power Silicon Transistor

Rev. V1

Features

- Available in JAN, JANTX, JANTXV, JANS and JANSR 100K rads(Si) per MIL-PRF-19500/393
- TO-5 & TO-39 (TO-205AD) Package

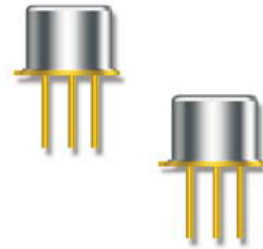

Electrical Characteristics

Parameter	Test Conditions	Symbol	Units	Min.	Max.
Off Characteristics					
Collector - Emitter Breakdown Voltage	$I_C = 50 \text{ mAdc}$ 2N3418, S, 2N3420, S 2N3419, S, 2N3421, S	$V_{(BR)CEO}$	Vdc	60 80	—
Collector - Emitter Cutoff Current	$V_{CE} = 80 \text{ Vdc}, V_{BE} = -0.5 \text{ Vdc}$ 2N3418, S, 2N3420, S $V_{CE} = 120 \text{ Vdc}, V_{BE} = -0.5 \text{ Vdc}$ 2N3419, S, 2N3421, S	I_{CEX}	μAdc	—	0.3 0.3
Collector - Emitter Cutoff Current	$V_{CE} = 45$ 2N3418, S, 2N3420, S $V_{CE} = 60$ 2N3419, S, 2N3421, S	I_{CEO}	μAdc	—	5.0 5.0
Emitter - Base Cutoff Current	$V_{EB} = 6 \text{ Vdc}, I_C = 0$ $V_{EB} = 8 \text{ Vdc}, I_C = 0$	I_{EBO}	μAdc	—	0.5 10.0
On Characteristics¹					
Forward Current Transfer Ratio	$I_C = 100 \text{ mAdc}, V_{CE} = 2 \text{ Vdc}$ 2N3418, S, 2N3419, S 2N3420, S, 2N3421, S	H_{FE}	-	20 40	— —
	$I_C = 1 \text{ Adc}, V_{CE} = 2 \text{ Vd}$ 2N3418, S, 2N3419, S 2N3420, S, 2N3421, S			20 40	60 120
	$I_C = 2 \text{ Adc}, V_{CE} = 2 \text{ Vdc}$ 2N3418, S, 2N3419, S 2N3420, S, 2N3421, S			15 30	— —
	$I_C = 5 \text{ Adc}, V_{CE} = 5 \text{ Vdc}$ 2N3418, S, 2N3419, S 2N3420, S, 2N3421, S			10 15	— —
	Base - Emitter Voltage			$I_C = 1 \text{ Adc}, I_B = 0.1 \text{ Adc}$ $I_C = 2 \text{ Adc}, I_B = 0.2 \text{ Adc}$	$V_{BE(SAT)}$
Collector - Emitter Saturation Voltage	$I_C = 1 \text{ Adc}, I_B = 0.1 \text{ Adc}$ $I_C = 2 \text{ Adc}, I_B = 0.2 \text{ Adc}$	$V_{CE(SAT)}$	Vdc	—	0.25 0.50

2N3418(S) - 2N3421(S) Series



NPN Medium Power Silicon Transistor

Rev. V1

Electrical Characteristics

Parameter	Test Conditions	Symbol	Units	Min.	Max.
Dynamic Characteristics					
Magnitude of Common Emitter Small-Signal Short-Circuit Forward Current Transfer Ratio	$I_C = 0.1 \text{ Adc}$, $V_{CE} = 10 \text{ Vdc}$, $f = 20 \text{ MHz}$	$ H_{FE} $	-	1.3	8.0
Output Capacitance	$V_{CB} = 10 \text{ Vdc}$, $I_E = 0$, $100 \text{ kHz} \leq f \leq 1 \text{ MHz}$	C_{OBO}	pF	—	150
Switching Characteristics					
Delay Time	$V_{BE(OFF)} = -3.7 \text{ Vdc}$; $I_C = 1 \text{ Adc}$; $I_{B2} = 100 \text{ mAdc}$	T_D	μs	—	0.08
Rise Time		T_R			0.22
Storage Time	$V_{BE(OFF)} = -3.7 \text{ Vdc}$; $I_C = 1 \text{ Adc}$; $I_{B2} = 100 \text{ mAdc}$	T_S	μs	—	1.10
Fall Time		T_F			0.20
Safe Operating Area					
DC Tests:	$T_C = +100 \text{ }^\circ\text{C}$, 1 Cycle, $t = 1.0 \text{ s}$				
Test 1:	$V_{CE} = 5 \text{ Vdc}$, $I_C = 3.0 \text{ Adc}$				
Test 2:	$V_{CE} = 37 \text{ Vdc}$, $I_C = 0.4 \text{ Adc}$				
Test 3:	$V_{CE} = 60 \text{ Vdc}$, $I_C = 0.185 \text{ mAdc}$ 2N3418, S; 2N3420, S				
	$V_{CE} = 80 \text{ Vdc}$, $I_C = 0.120 \text{ mAdc}$ 2N3419, S; 2N3421, S				

Absolute Maximum Ratings

Ratings	Symbol	Value 2N3418, S 2N3420, S	Value 2N3419, S 2N3421, S
Collector - Emitter Voltage	V_{CEO}	60 Vdc	80 Vdc
Collector - Base Voltage	V_{CBO}	85 Vdc	125 Vdc
Emitter - Base Voltage	V_{EBO}	8 Vdc	
Collector Current	I_C	3 Adc	
$T_P \leq 1 \text{ ms}$, duty cycle $\leq 50\%$		5 Adc	
Total Power Dissipation	P_T	1 W	
@ $T_A = 25^\circ\text{C}$		5 W	
@ $T_C = 100^\circ\text{C}$			
Operating & Storage Temperature Range	T_{OP} , T_{STG}	-65°C to +200°C	

2N3418(S) - 2N3421(S) Series



NPN Medium Power Silicon Transistor

Rev. V1

Outline Drawing (TO-5 & TO-39)

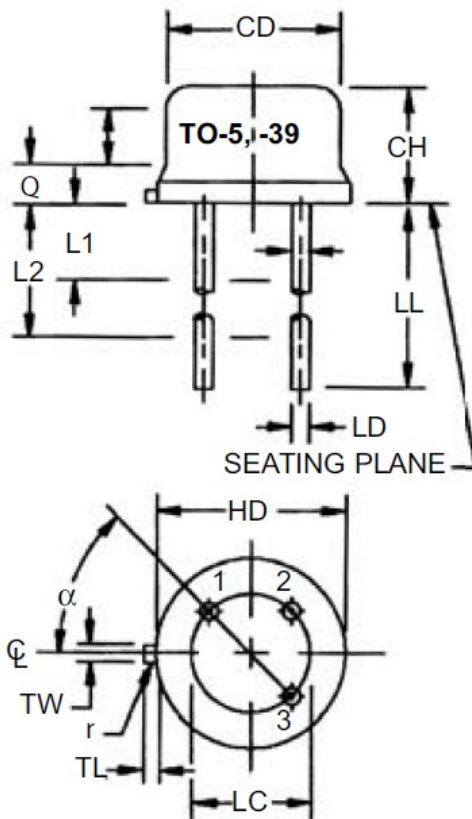

LTR	Dimensions				Note
	Inches		Millimeters		
	MIN	MAX	MIN	MAX	
CD	0.305	0.335	7.75	8.51	—
CH	0.240	0.260	6.10	6.60	—
HD	0.335	0.370	8.51	9.40	—
LC	0.200 TP		5.08 TP		7
LD	0.016	0.019	0.041	0.048	8, 9
LL	0.500	0.750	12.7	19.05	—
LU	0.016	0.019	0.041	0.048	8, 9
L1	—	0.050	—	1.27	8, 9
L2	0.250	—	6.35	—	8, 9
P	0.100	—	2.54	—	7
Q	—	0.030	—	0.76	5
TL	0.029	0.045	0.74	1.14	—
TW	0.028	0.034	0.71	0.86	—
r	—	0.010	—	0.25	10
a	45° TP		45° TP		7
1, 2, 10, 12, 13, 14					

1. Dimensions are in inches.
2. Millimeters are given for general information only.
3. Beyond r (radius) maximum, TW shall be held for a minimum length of .011 (0.28 mm).
4. Dimension TL measured from maximum HD.
5. Body contour optional within zone defined by HD, CD, and Q.
6. CD shall not vary more than .010 inch (0.25 mm) in zone P. This zone is controlled for automatic handling.
7. Leads at gauge plane .054 +.001 -.000 inch (1.37 +0.03 -0.00 mm) below seating plane shall be within 0.007 inch (0.18 mm) radius of true position (TP) at maximum material condition (MMC) relative to tab at MMC. The device may be measured by direct methods or by gauging procedure.
8. Dimension LU applies between L₁ and L₂. Dimension LD applies between L₁ and LL minimum. Diameter is uncontrolled in and beyond LL minimum.
9. All three leads.
10. The collector shall be internally connected to the case.
11. Dimension r (radius) applies to both inside corners of tab.
12. In accordance with ASME Y14.5M, diameters are equivalent to Φ x symbology.
13. Lead 1 = emitter, lead 2 = base, lead 3 = collector.
14. For non-S-suffix devices (T0-5), dimension LL = 1.5 inches (38.10 mm) min. and 1.75 inches (44.45 mm) max. For S-suffix types (T0-39), dimension LL = 0.5 inch (12.70 mm) min. and 750 inch (19.05 mm) max.

2N3418(S) - 2N3421(S) Series



NPN Medium Power Silicon Transistor

Rev. V1

M/A-COM Technology Solutions Inc. All rights reserved.

Information in this document is provided in connection with M/A-COM Technology Solutions Inc ("MACOM") products. These materials are provided by MACOM as a service to its customers and may be used for informational purposes only. Except as provided in MACOM's Terms and Conditions of Sale for such products or in any separate agreement related to this document, MACOM assumes no liability whatsoever. MACOM assumes no responsibility for errors or omissions in these materials. MACOM may make changes to specifications and product descriptions at any time, without notice. MACOM makes no commitment to update the information and shall have no responsibility whatsoever for conflicts or incompatibilities arising from future changes to its specifications and product descriptions. No license, express or implied, by estoppel or otherwise, to any intellectual property rights is granted by this document.

THESE MATERIALS ARE PROVIDED "AS IS" WITHOUT WARRANTY OF ANY KIND, EITHER EXPRESS OR IMPLIED, RELATING TO SALE AND/OR USE OF MACOM PRODUCTS INCLUDING LIABILITY OR WARRANTIES RELATING TO FITNESS FOR A PARTICULAR PURPOSE, CONSEQUENTIAL OR INCIDENTAL DAMAGES, MERCHANTABILITY, OR INFRINGEMENT OF ANY PATENT, COPYRIGHT OR OTHER INTELLECTUAL PROPERTY RIGHT. MACOM FURTHER DOES NOT WARRANT THE ACCURACY OR COMPLETENESS OF THE INFORMATION, TEXT, GRAPHICS OR OTHER ITEMS CONTAINED WITHIN THESE MATERIALS. MACOM SHALL NOT BE LIABLE FOR ANY SPECIAL, INDIRECT, INCIDENTAL, OR CONSEQUENTIAL DAMAGES, INCLUDING WITHOUT LIMITATION, LOST REVENUES OR LOST PROFITS, WHICH MAY RESULT FROM THE USE OF THESE MATERIALS.

MACOM products are not intended for use in medical, lifesaving or life sustaining applications. MACOM customers using or selling MACOM products for use in such applications do so at their own risk and agree to fully indemnify MACOM for any damages resulting from such improper use or sale.