

HSG2002

SiGe HBT High Frequency Medium Power Amplifier

REJ03G0444-0100

Rev.1.00

Oct.28.2004

Features

- High Transition Frequency
 $f_T = 28.5$ GHz typ.
- Low Distortion and Excellent Linearity
P1dB at output = +25 dBm typ. $f = 5.8$ GHz
- High Collector to Emitter Voltage
 $V_{CEO} = 5$ V
- Ideal for 2 GHz, 5 GHz Band applications. e.g WLAN, Digital cordless phone.

Outline

WQFN0202-8V

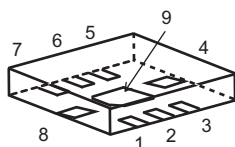
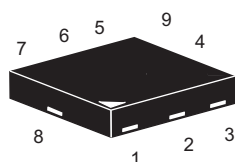

1. Collector
2. Collector
3. Collector
4. Emitter
5. Emitter
6. Base
7. Emitter
8. Emitter
9. Emitter

Note: Marking is "2002".

Absolute Maximum Ratings

($T_a = 25^\circ\text{C}$)

Item	Symbol	Ratings	Unit
Collector to base voltage	V_{CBO}	12	V
Collector to emitter voltage	V_{CEO}	5	V
Emitter to base voltage	V_{EBO}	1.5	V
Collector current	I_C	500	mA
Collector power dissipation	P_C	1 ^{Note}	W
Junction temperature	T_j	150	$^\circ\text{C}$
Storage temperature	T_{stg}	-55 to +150	$^\circ\text{C}$

Note: Value on PCB (40 x 40 x 1.0mm)

Electrical Characteristics

(Ta = 25°C)

Item	Symbol	Min	Typ	Max	Unit	Test Conditions
DC current transfer ratio	h_{FE}	170	240	320	—	$V_{CE} = 3\text{ V}$, $I_C = 100\text{ mA}$
Reverse Transfer Capacitance	C_{re}	—	—	1.0	pF	$V_{CB} = 3\text{ V}$, $I_E = 0$, $f = 1\text{ MHz}$ emitter grounded
Transition Frequency	f_T	—	28.5	—	GHz	$V_{CE} = 3\text{ V}$, $I_C = 250\text{ mA}$ $f = 1\text{ GHz}$
Maximum Available Gain	MAG	—	15	—	dB	$V_{CE} = 3\text{ V}$, $I_C = 250\text{ mA}$, $f = 2.4\text{ GHz}$,
Maximum Available Gain	MAG	—	7	—	dB	$V_{CE} = 3\text{ V}$, $I_C = 250\text{ mA}$, $f = 5.8\text{ GHz}$,
Power Gain	PG	—	5.5	—	dB	$V_{CE} = 3.6\text{ V}$, $I_{Cq} = 100\text{ mA}$, $f = 5.8\text{ GHz}$, $P_{in} = +20\text{ dBm}$
1dB Compression Point at output	P1dB	—	+25	—	dBm	$V_{CE} = 3.6\text{ V}$, $I_{Cq} = 100\text{ mA}$, $f = 5.8\text{ GHz}$
Saturation Output Power	Po(sat)	—	+27	—	dBm	$V_{CE} = 3.6\text{ V}$, $I_{Cq} = 100\text{ mA}$ $f = 5.8\text{ GHz}$, $P_{in} = +25\text{ dBm}$

Main Characteristics

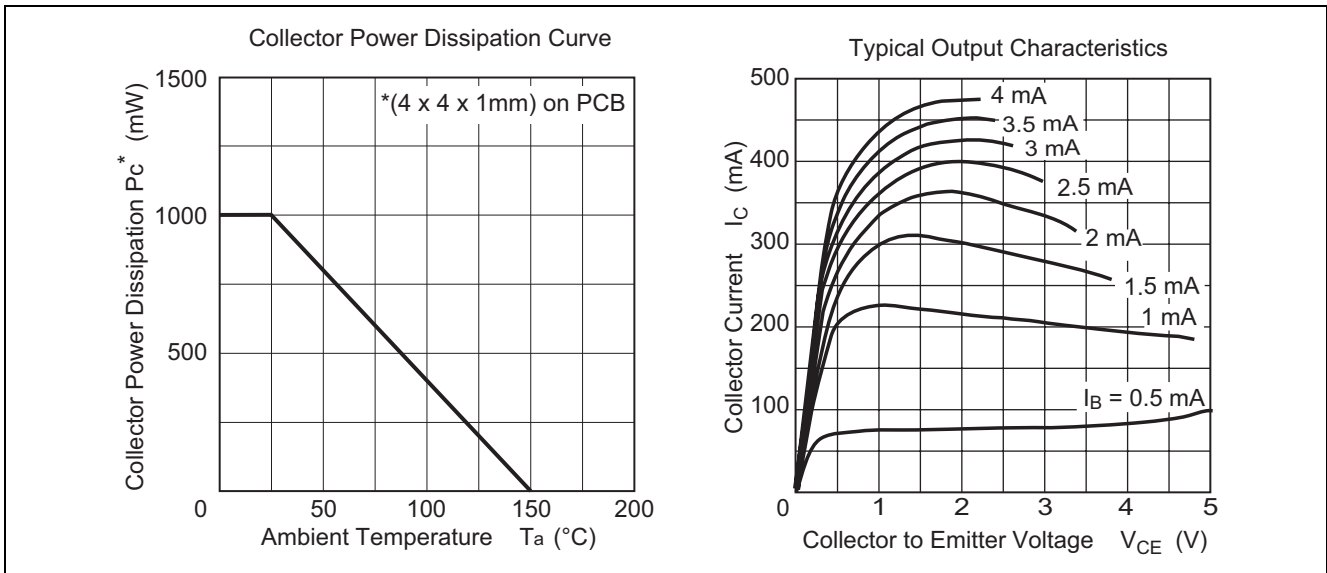

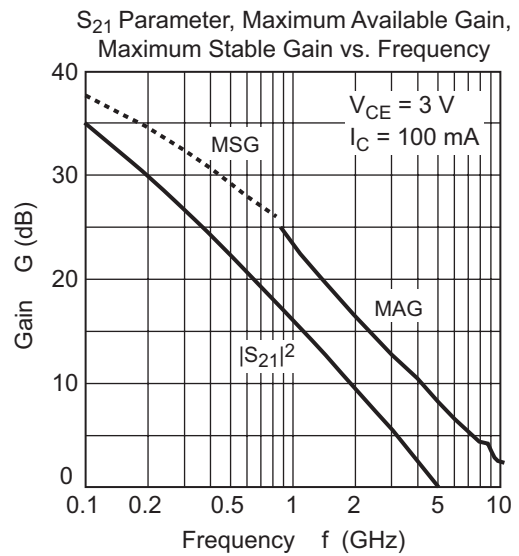
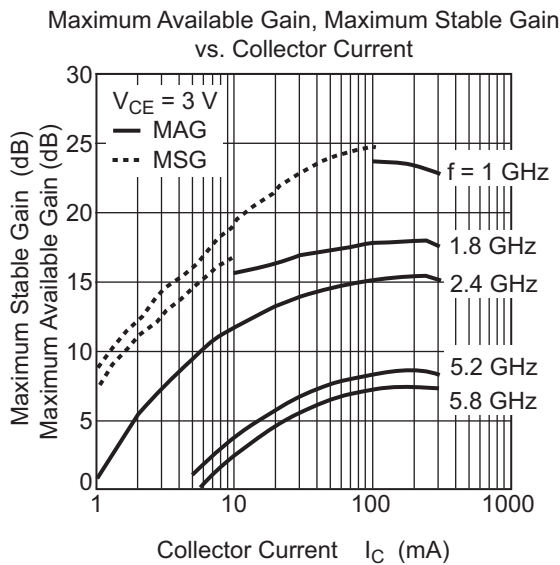
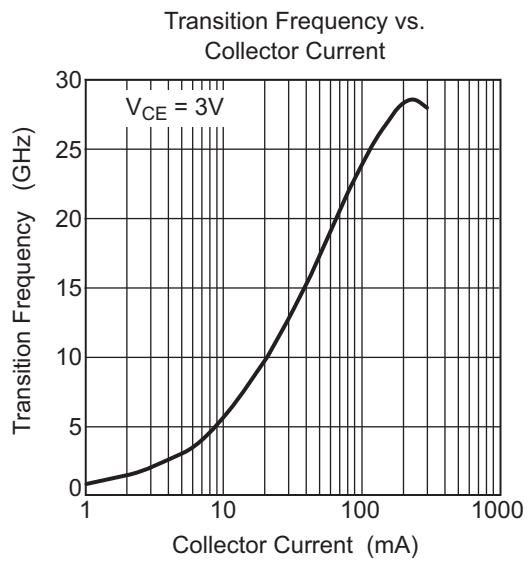
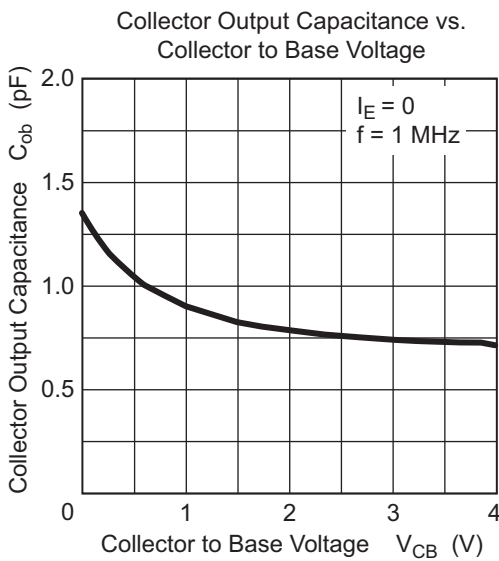
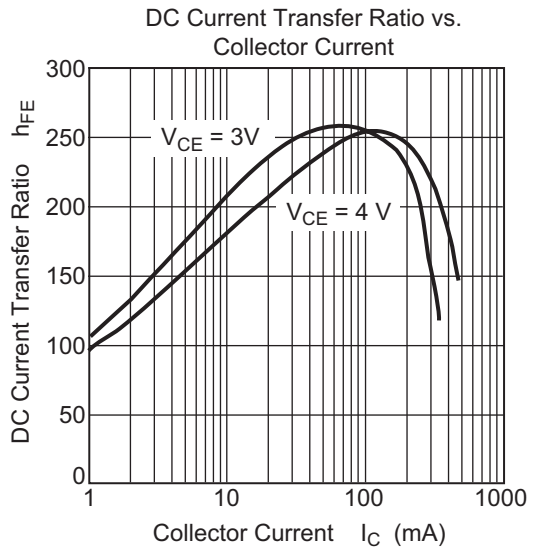
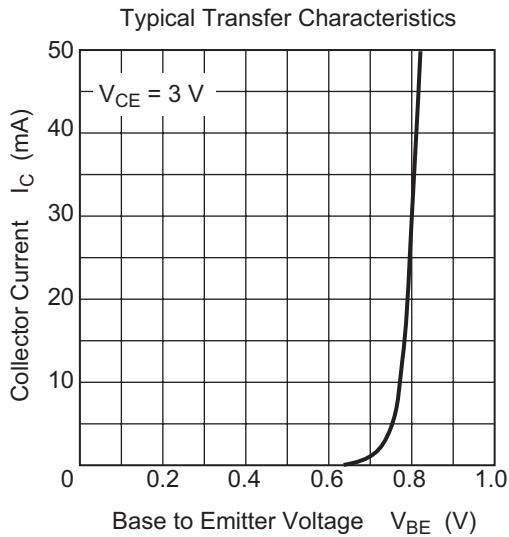

5.8GHz Characteristics

Evaluation Board Circuit

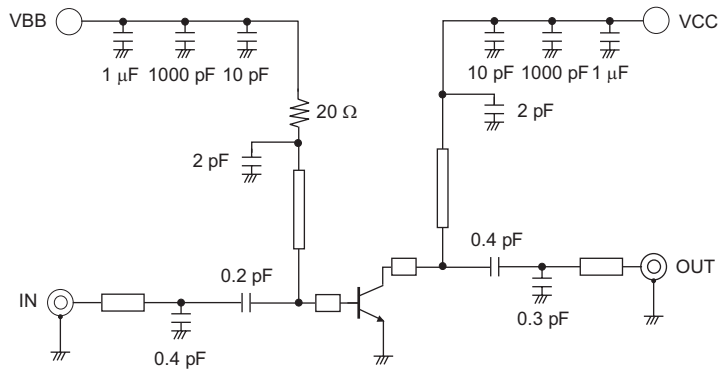

Pin - Pout Characteristics

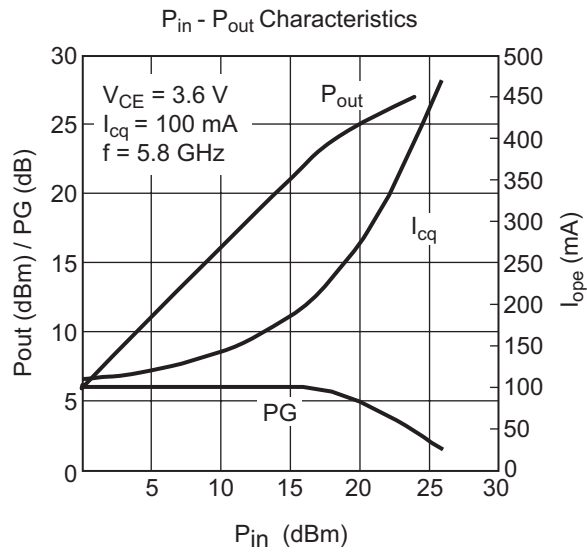

S₁₁ Parameter vs. Frequency

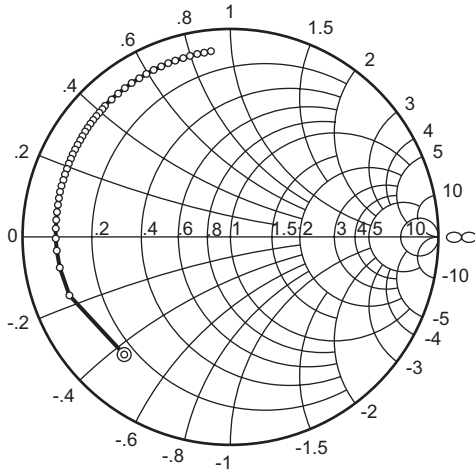

Condition: $V_{CE} = 3\text{ V}$, $I_C = 50\text{ mA}$, $Z_o = 50\ \Omega$
 100 to 3000 MHz (100 MHz Step)
 3200 to 6000 MHz (200 MHz Step)

S₂₁ Parameter vs. Frequency

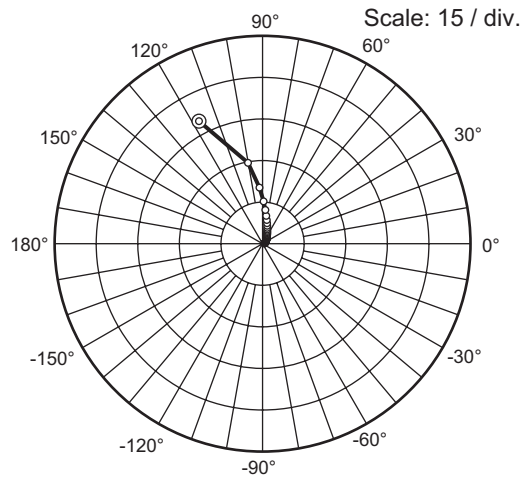

Condition: $V_{CE} = 3\text{ V}$, $I_C = 50\text{ mA}$, $Z_o = 50\ \Omega$
 100 to 3000 MHz (100 MHz Step)
 3200 to 6000 MHz (200 MHz Step)

S₁₂ Parameter vs. Frequency

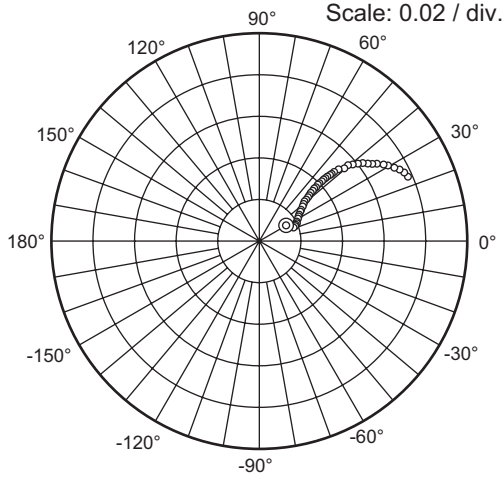

Condition: $V_{CE} = 3\text{ V}$, $I_C = 50\text{ mA}$, $Z_o = 50\ \Omega$
 100 to 3000 MHz (100 MHz Step)
 3200 to 6000 MHz (200 MHz Step)

S₂₂ Parameter vs. Frequency

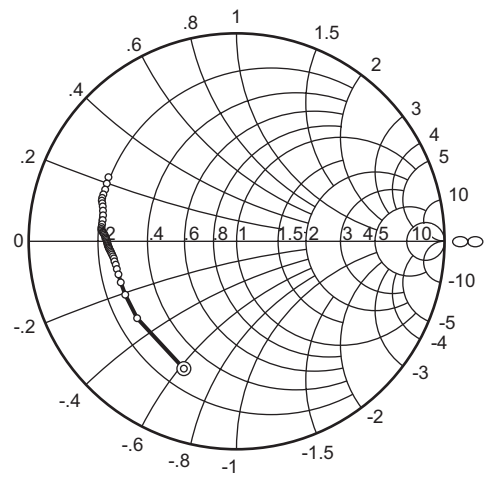

Condition: $V_{CE} = 3\text{ V}$, $I_C = 50\text{ mA}$, $Z_o = 50\ \Omega$
 100 to 3000 MHz (100 MHz Step)
 3200 to 6000 MHz (200 MHz Step)

S₁₁ Parameter vs. Frequency

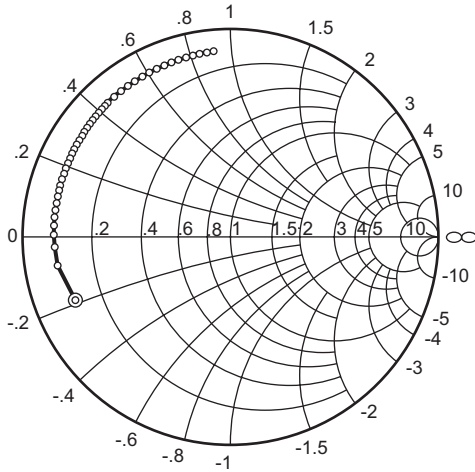

Condition: $V_{CE} = 3\text{ V}$, $I_C = 100\text{ mA}$, $Z_o = 50\ \Omega$
 100 to 3000 MHz (100 MHz Step)
 3200 to 6000 MHz (200 MHz Step)

S₂₁ Parameter vs. Frequency

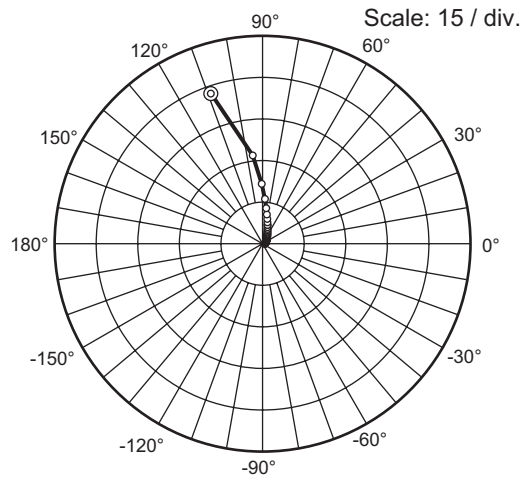

Condition: $V_{CE} = 3\text{ V}$, $I_C = 100\text{ mA}$, $Z_o = 50\ \Omega$
 100 to 3000 MHz (100 MHz Step)
 3200 to 6000 MHz (200 MHz Step)

S₁₂ Parameter vs. Frequency

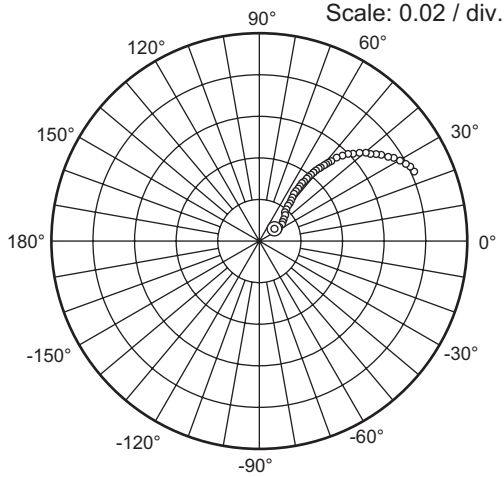

Condition: $V_{CE} = 3\text{ V}$, $I_C = 100\text{ mA}$, $Z_o = 50\ \Omega$
 100 to 3000 MHz (100 MHz Step)
 3200 to 6000 MHz (200 MHz Step)

S₂₂ Parameter vs. Frequency

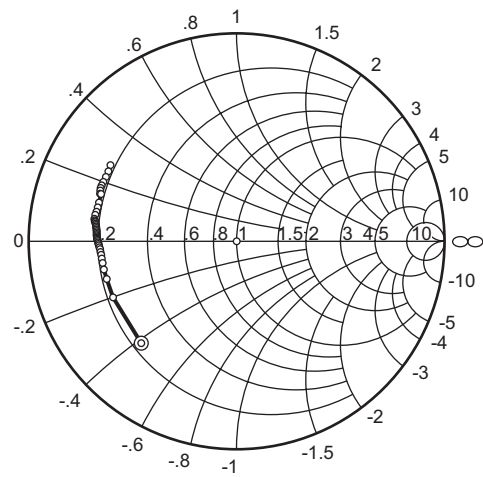

Condition: $V_{CE} = 3\text{ V}$, $I_C = 100\text{ mA}$, $Z_o = 50\ \Omega$
 100 to 3000 MHz (100 MHz Step)
 3200 to 6000 MHz (200 MHz Step)

S₁₁ Parameter vs. Frequency

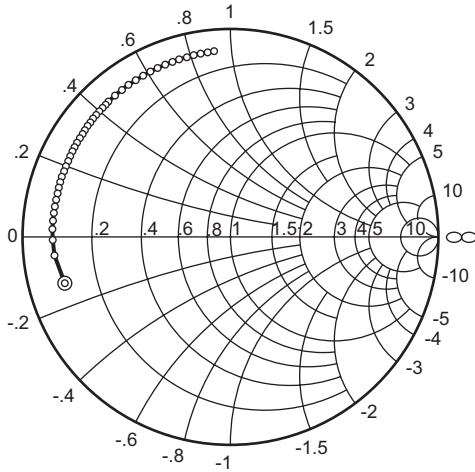

Condition: $V_{CE} = 3\text{ V}$, $I_C = 150\text{ mA}$, $Z_o = 50\ \Omega$
 100 to 3000 MHz (100 MHz Step)
 3200 to 6000 MHz (200 MHz Step)

S₂₁ Parameter vs. Frequency

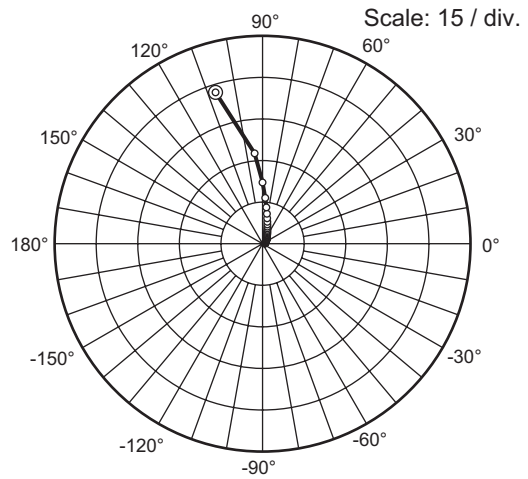

Condition: $V_{CE} = 3\text{ V}$, $I_C = 150\text{ mA}$, $Z_o = 50\ \Omega$
 100 to 3000 MHz (100 MHz Step)
 3200 to 6000 MHz (200 MHz Step)

S₁₂ Parameter vs. Frequency

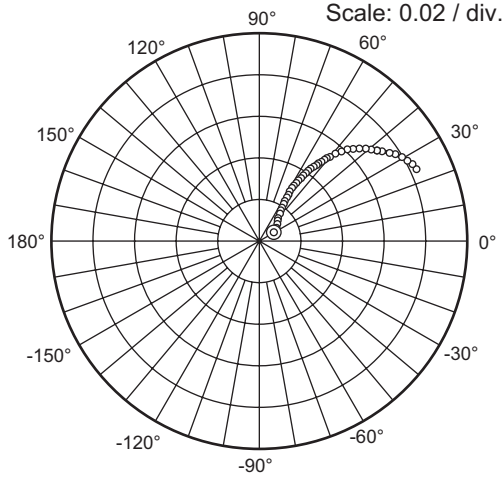

Condition: $V_{CE} = 3\text{ V}$, $I_C = 150\text{ mA}$, $Z_o = 50\ \Omega$
 100 to 3000 MHz (100 MHz Step)
 3200 to 6000 MHz (200 MHz Step)

S₂₂ Parameter vs. Frequency

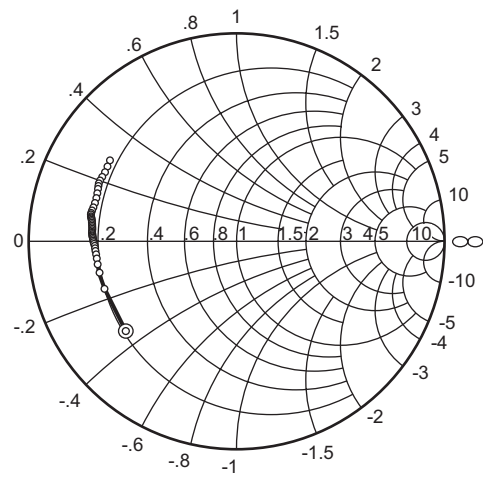

Condition: $V_{CE} = 3\text{ V}$, $I_C = 150\text{ mA}$, $Z_o = 50\ \Omega$
 100 to 3000 MHz (100 MHz Step)
 3200 to 6000 MHz (200 MHz Step)

S₁₁ Parameter vs. Frequency

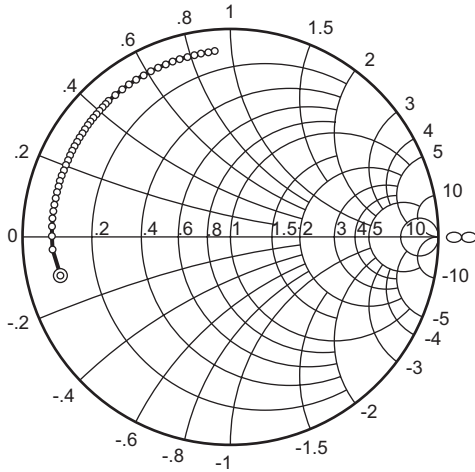

Condition: $V_{CE} = 3\text{ V}$, $I_C = 200\text{ mA}$, $Z_o = 50\ \Omega$
 100 to 3000 MHz (100 MHz Step)
 3200 to 6000 MHz (200 MHz Step)

S₂₁ Parameter vs. Frequency

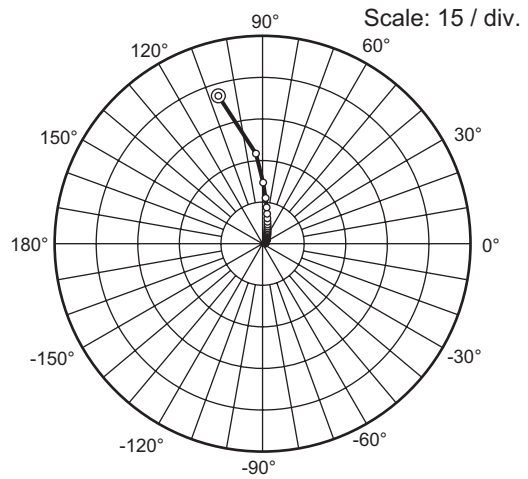

Condition: $V_{CE} = 3\text{ V}$, $I_C = 200\text{ mA}$, $Z_o = 50\ \Omega$
 100 to 3000 MHz (100 MHz Step)
 3200 to 6000 MHz (200 MHz Step)

S₁₂ Parameter vs. Frequency

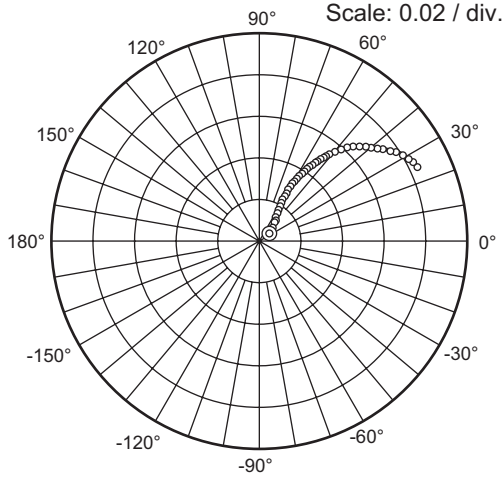

Condition: $V_{CE} = 3\text{ V}$, $I_C = 200\text{ mA}$, $Z_o = 50\ \Omega$
 100 to 3000 MHz (100 MHz Step)
 3200 to 6000 MHz (200 MHz Step)

S₂₂ Parameter vs. Frequency

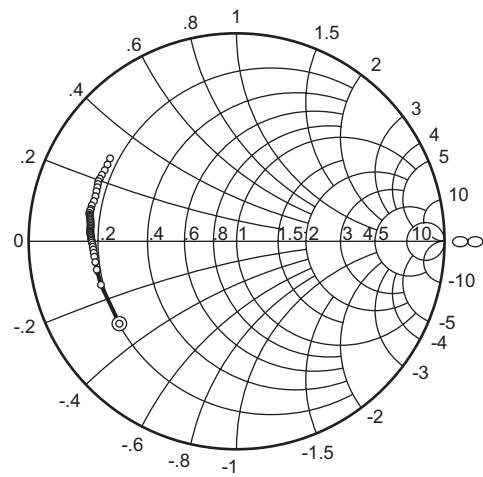

Condition: $V_{CE} = 3\text{ V}$, $I_C = 200\text{ mA}$, $Z_o = 50\ \Omega$
 100 to 3000 MHz (100 MHz Step)
 3200 to 6000 MHz (200 MHz Step)

S₁₁ Parameter vs. Frequency

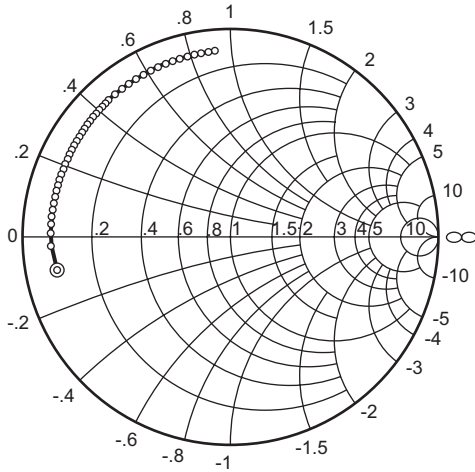

Condition: $V_{CE} = 3\text{ V}$, $I_C = 250\text{ mA}$, $Z_o = 50\ \Omega$
 100 to 3000 MHz (100 MHz Step)
 3200 to 6000 MHz (200 MHz Step)

S₂₁ Parameter vs. Frequency

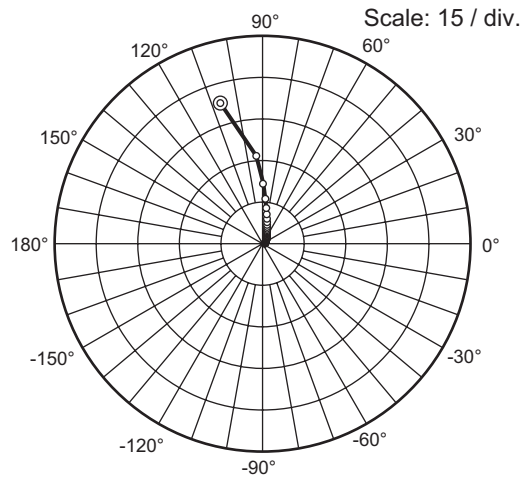

Condition: $V_{CE} = 3\text{ V}$, $I_C = 250\text{ mA}$, $Z_o = 50\ \Omega$
 100 to 3000 MHz (100 MHz Step)
 3200 to 6000 MHz (200 MHz Step)

S₁₂ Parameter vs. Frequency

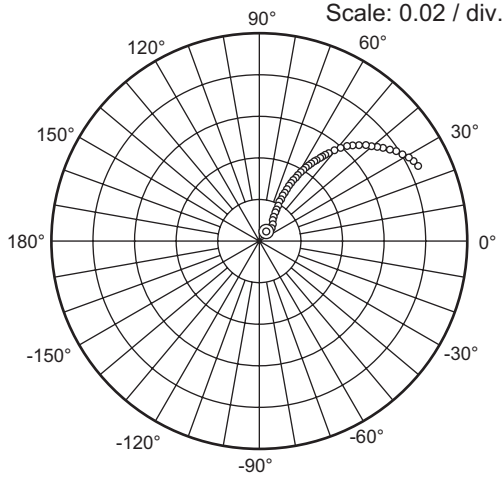

Condition: $V_{CE} = 3\text{ V}$, $I_C = 250\text{ mA}$, $Z_o = 50\ \Omega$
 100 to 3000 MHz (100 MHz Step)
 3200 to 6000 MHz (200 MHz Step)

S₂₂ Parameter vs. Frequency

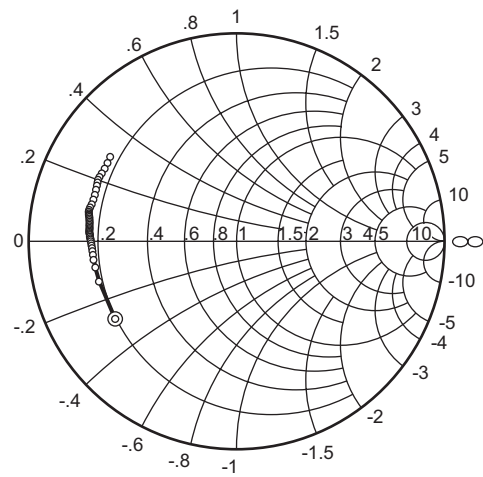

Condition: $V_{CE} = 3\text{ V}$, $I_C = 250\text{ mA}$, $Z_o = 50\ \Omega$
 100 to 3000 MHz (100 MHz Step)
 3200 to 6000 MHz (200 MHz Step)

S₁₁ Parameter vs. Frequency

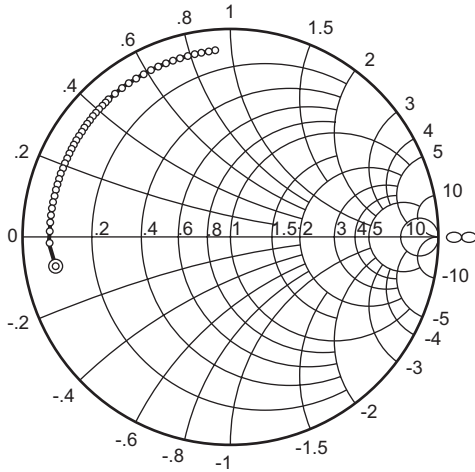

Condition: $V_{CE} = 3\text{ V}$, $I_C = 300\text{ mA}$, $Z_o = 50\ \Omega$
 100 to 3000 MHz (100 MHz Step)
 3200 to 6000 MHz (200 MHz Step)

S₂₁ Parameter vs. Frequency

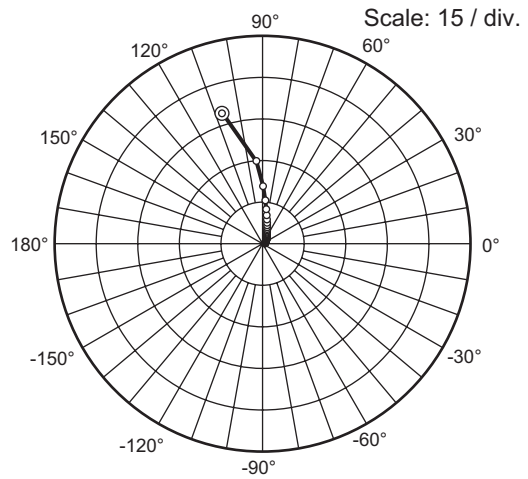

Condition: $V_{CE} = 3\text{ V}$, $I_C = 300\text{ mA}$, $Z_o = 50\ \Omega$
 100 to 3000 MHz (100 MHz Step)
 3200 to 6000 MHz (200 MHz Step)

S₁₂ Parameter vs. Frequency

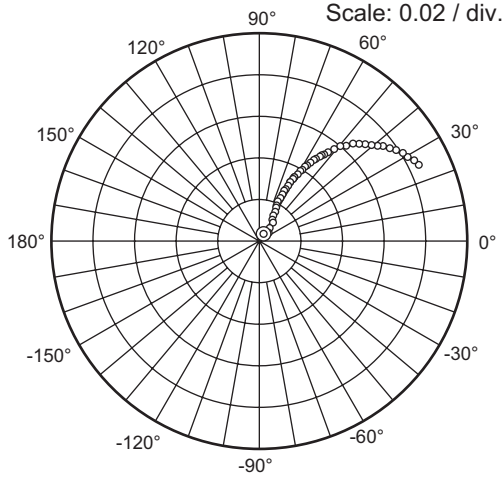

Condition: $V_{CE} = 3\text{ V}$, $I_C = 300\text{ mA}$, $Z_o = 50\ \Omega$
 100 to 3000 MHz (100 MHz Step)
 3200 to 6000 MHz (200 MHz Step)

S₂₂ Parameter vs. Frequency

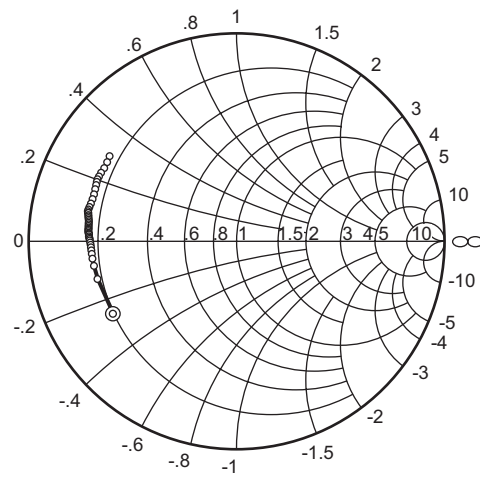

Condition: $V_{CE} = 3\text{ V}$, $I_C = 300\text{ mA}$, $Z_o = 50\ \Omega$
 100 to 3000 MHz (100 MHz Step)
 3200 to 6000 MHz (200 MHz Step)

S₁₁ Parameter vs. Frequency

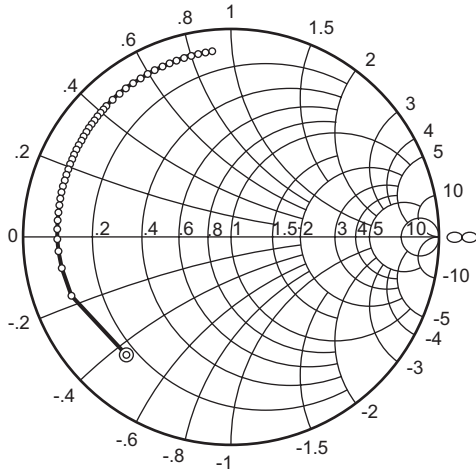

Condition: $V_{CE} = 3.3\text{ V}$, $I_C = 50\text{ mA}$, $Z_o = 50\ \Omega$
 100 to 3000 MHz (100 MHz Step)
 3200 to 6000 MHz (200 MHz Step)

S₂₁ Parameter vs. Frequency

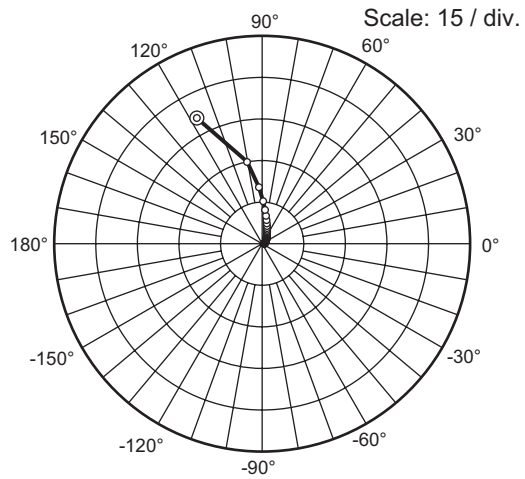

Condition: $V_{CE} = 3.3\text{ V}$, $I_C = 50\text{ mA}$, $Z_o = 50\ \Omega$
 100 to 3000 MHz (100 MHz Step)
 3200 to 6000 MHz (200 MHz Step)

S₁₂ Parameter vs. Frequency

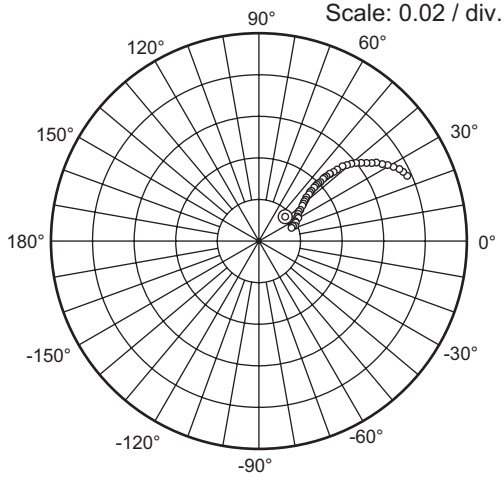

Condition: $V_{CE} = 3.3\text{ V}$, $I_C = 50\text{ mA}$, $Z_o = 50\ \Omega$
 100 to 3000 MHz (100 MHz Step)
 3200 to 6000 MHz (200 MHz Step)

S₂₂ Parameter vs. Frequency

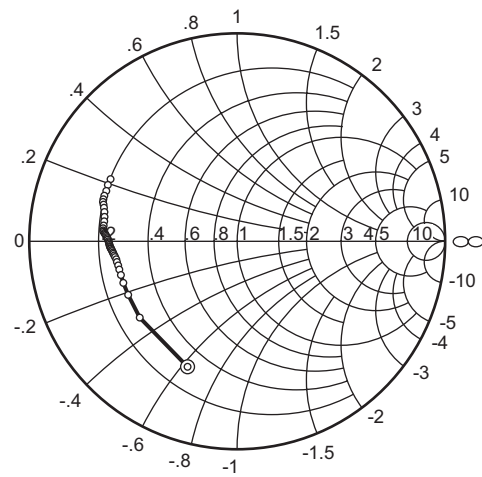

Condition: $V_{CE} = 3.3\text{ V}$, $I_C = 50\text{ mA}$, $Z_o = 50\ \Omega$
 100 to 3000 MHz (100 MHz Step)
 3200 to 6000 MHz (200 MHz Step)

S₁₁ Parameter vs. Frequency

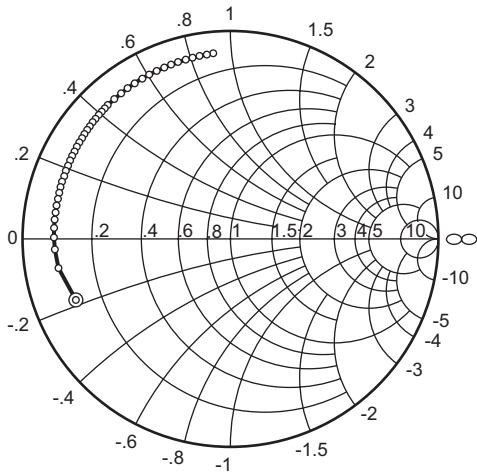

Condition: $V_{CE} = 3.3\text{ V}$, $I_C = 100\text{ mA}$, $Z_o = 50\ \Omega$
 100 to 3000 MHz (100 MHz Step)
 3200 to 6000 MHz (200 MHz Step)

S₂₁ Parameter vs. Frequency

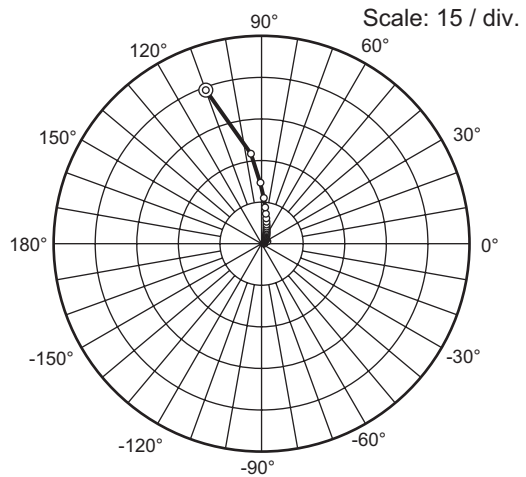

Condition: $V_{CE} = 3.3\text{ V}$, $I_C = 100\text{ mA}$, $Z_o = 50\ \Omega$
 100 to 3000 MHz (100 MHz Step)
 3200 to 6000 MHz (200 MHz Step)

S₁₂ Parameter vs. Frequency

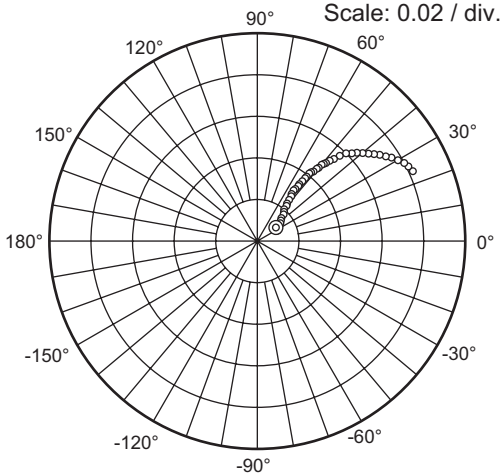

Condition: $V_{CE} = 3.3\text{ V}$, $I_C = 100\text{ mA}$, $Z_o = 50\ \Omega$
 100 to 3000 MHz (100 MHz Step)
 3200 to 6000 MHz (200 MHz Step)

S₂₂ Parameter vs. Frequency

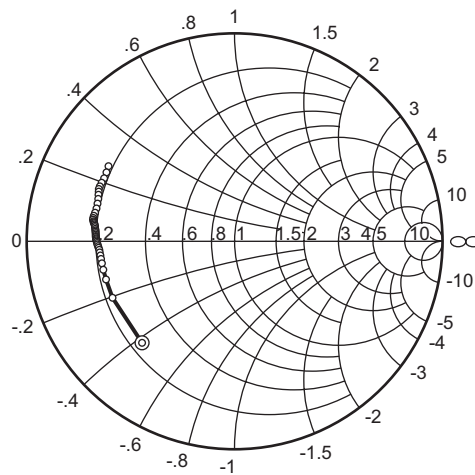

Condition: $V_{CE} = 3.3\text{ V}$, $I_C = 100\text{ mA}$, $Z_o = 50\ \Omega$
 100 to 3000 MHz (100 MHz Step)
 3200 to 6000 MHz (200 MHz Step)

S₁₁ Parameter vs. Frequency

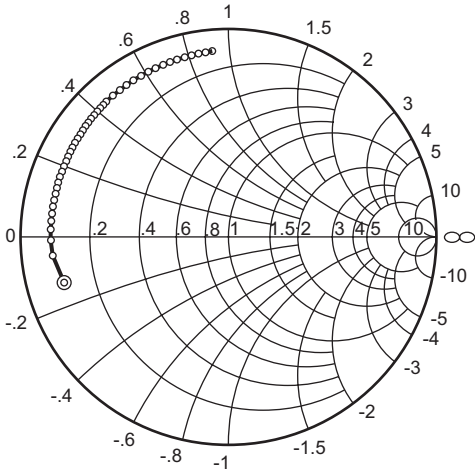

Condition: $V_{CE} = 3.3\text{ V}$, $I_C = 150\text{ mA}$, $Z_o = 50\ \Omega$
 100 to 3000 MHz (100 MHz Step)
 3200 to 6000 MHz (200 MHz Step)

S₂₁ Parameter vs. Frequency

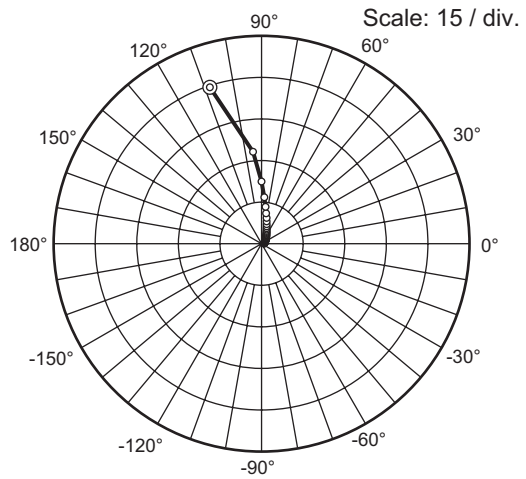

Condition: $V_{CE} = 3.3\text{ V}$, $I_C = 150\text{ mA}$, $Z_o = 50\ \Omega$
 100 to 3000 MHz (100 MHz Step)
 3200 to 6000 MHz (200 MHz Step)

S₁₂ Parameter vs. Frequency

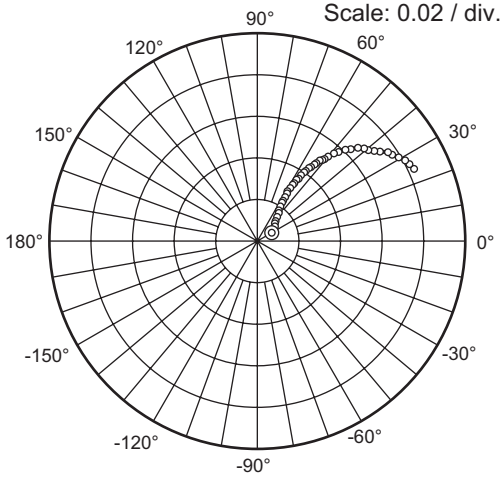

Condition: $V_{CE} = 3.3\text{ V}$, $I_C = 150\text{ mA}$, $Z_o = 50\ \Omega$
 100 to 3000 MHz (100 MHz Step)
 3200 to 6000 MHz (200 MHz Step)

S₂₂ Parameter vs. Frequency

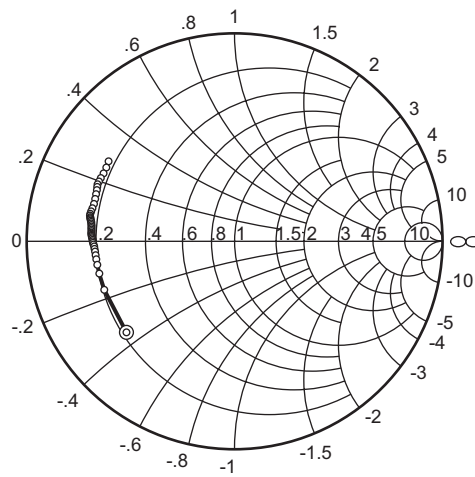

Condition: $V_{CE} = 3.3\text{ V}$, $I_C = 150\text{ mA}$, $Z_o = 50\ \Omega$
 100 to 3000 MHz (100 MHz Step)
 3200 to 6000 MHz (200 MHz Step)

S₁₁ Parameter vs. Frequency

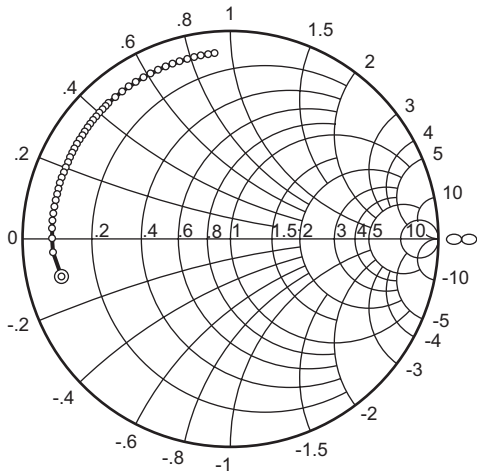

Condition: $V_{CE} = 3.3\text{ V}$, $I_C = 200\text{ mA}$, $Z_o = 50\ \Omega$
 100 to 3000 MHz (100 MHz Step)
 3200 to 6000 MHz (200 MHz Step)

S₂₁ Parameter vs. Frequency

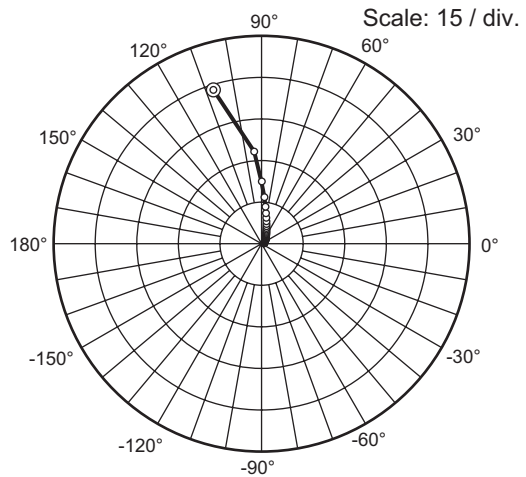

Condition: $V_{CE} = 3.3\text{ V}$, $I_C = 200\text{ mA}$, $Z_o = 50\ \Omega$
 100 to 3000 MHz (100 MHz Step)
 3200 to 6000 MHz (200 MHz Step)

S₁₂ Parameter vs. Frequency

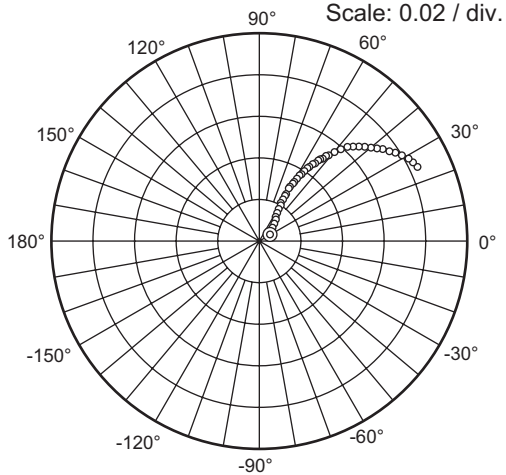

Condition: $V_{CE} = 3.3\text{ V}$, $I_C = 200\text{ mA}$, $Z_o = 50\ \Omega$
 100 to 3000 MHz (100 MHz Step)
 3200 to 6000 MHz (200 MHz Step)

S₂₂ Parameter vs. Frequency

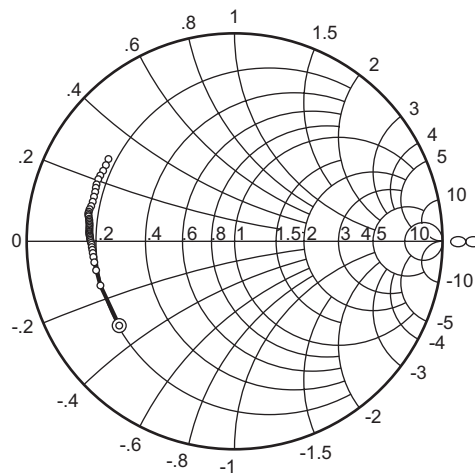

Condition: $V_{CE} = 3.3\text{ V}$, $I_C = 200\text{ mA}$, $Z_o = 50\ \Omega$
 100 to 3000 MHz (100 MHz Step)
 3200 to 6000 MHz (200 MHz Step)

S₁₁ Parameter vs. Frequency

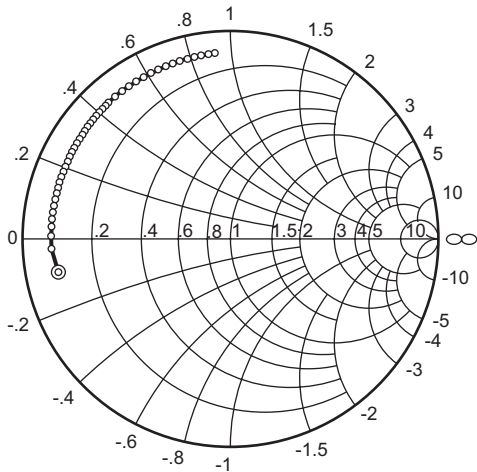

Condition: $V_{CE} = 3.3\text{ V}$, $I_C = 250\text{ mA}$, $Z_o = 50\ \Omega$
 100 to 3000 MHz (100 MHz Step)
 3200 to 6000 MHz (200 MHz Step)

S₂₁ Parameter vs. Frequency

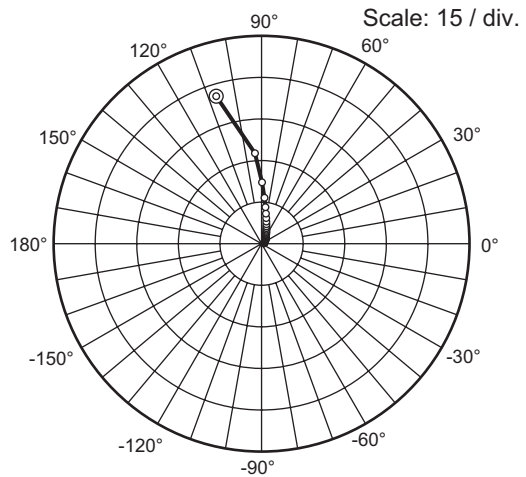

Condition: $V_{CE} = 3.3\text{ V}$, $I_C = 250\text{ mA}$, $Z_o = 50\ \Omega$
 100 to 3000 MHz (100 MHz Step)
 3200 to 6000 MHz (200 MHz Step)

S₁₂ Parameter vs. Frequency

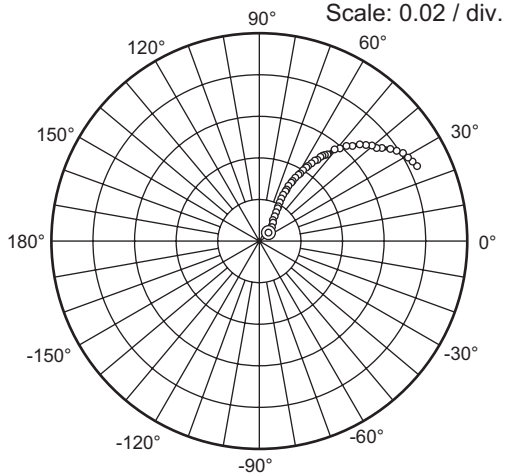

Condition: $V_{CE} = 3.3\text{ V}$, $I_C = 250\text{ mA}$, $Z_o = 50\ \Omega$
 100 to 3000 MHz (100 MHz Step)
 3200 to 6000 MHz (200 MHz Step)

S₂₂ Parameter vs. Frequency

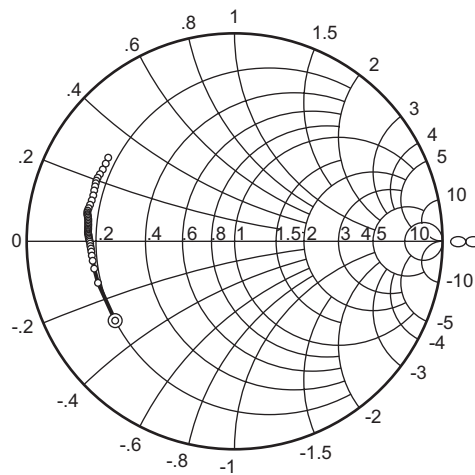

Condition: $V_{CE} = 3.3\text{ V}$, $I_C = 250\text{ mA}$, $Z_o = 50\ \Omega$
 100 to 3000 MHz (100 MHz Step)
 3200 to 6000 MHz (200 MHz Step)

S₁₁ Parameter vs. Frequency

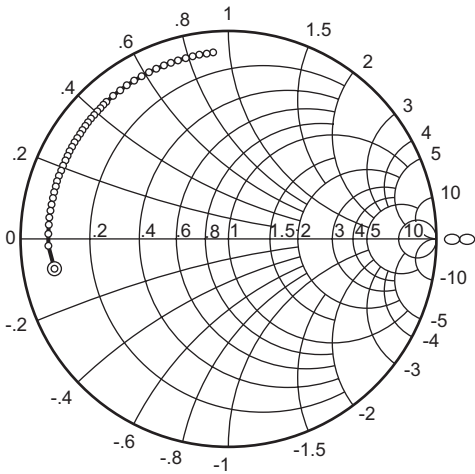

Condition: $V_{CE} = 3.3\text{ V}$, $I_C = 300\text{ mA}$, $Z_o = 50\ \Omega$
 100 to 3000 MHz (100 MHz Step)
 3200 to 6000 MHz (200 MHz Step)

S₂₁ Parameter vs. Frequency

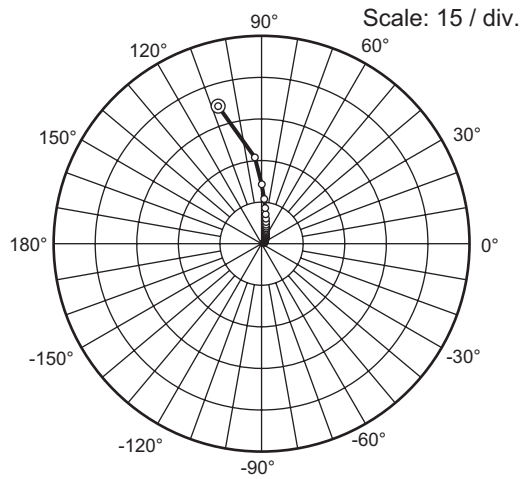

Condition: $V_{CE} = 3.3\text{ V}$, $I_C = 300\text{ mA}$, $Z_o = 50\ \Omega$
 100 to 3000 MHz (100 MHz Step)
 3200 to 6000 MHz (200 MHz Step)

S₁₂ Parameter vs. Frequency

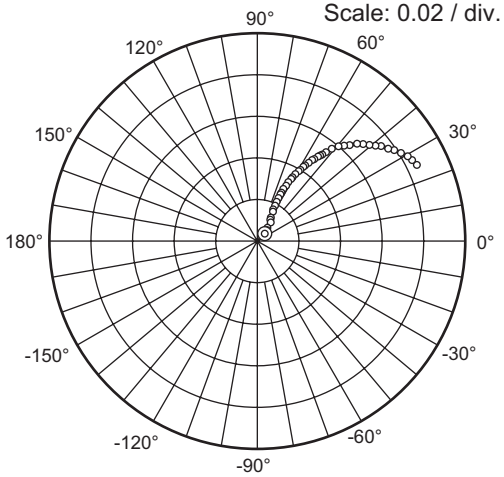

Condition: $V_{CE} = 3.3\text{ V}$, $I_C = 300\text{ mA}$, $Z_o = 50\ \Omega$
 100 to 3000 MHz (100 MHz Step)
 3200 to 6000 MHz (200 MHz Step)

S₂₂ Parameter vs. Frequency

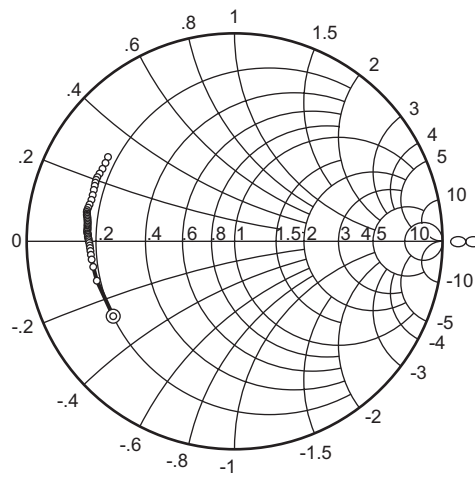

Condition: $V_{CE} = 3.3\text{ V}$, $I_C = 300\text{ mA}$, $Z_o = 50\ \Omega$
 100 to 3000 MHz (100 MHz Step)
 3200 to 6000 MHz (200 MHz Step)

S₁₁ Parameter vs. Frequency

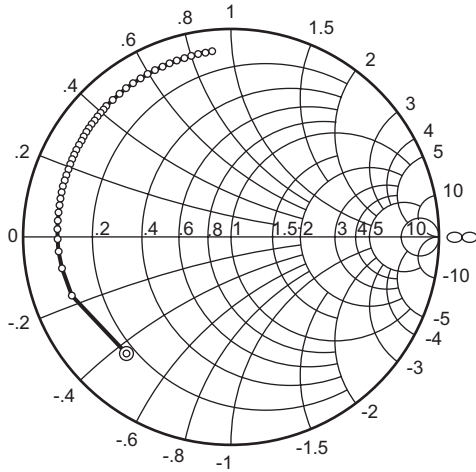

Condition: $V_{CE} = 3.6\text{ V}$, $I_C = 50\text{ mA}$, $Z_o = 50\ \Omega$
 100 to 3000 MHz (100 MHz Step)
 3200 to 6000 MHz (200 MHz Step)

S₂₁ Parameter vs. Frequency

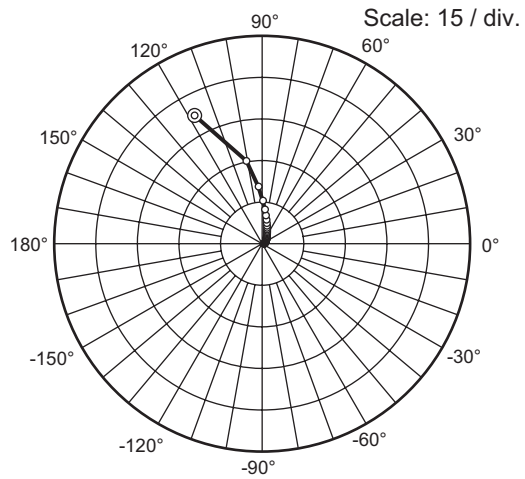

Condition: $V_{CE} = 3.6\text{ V}$, $I_C = 50\text{ mA}$, $Z_o = 50\ \Omega$
 100 to 3000 MHz (100 MHz Step)
 3200 to 6000 MHz (200 MHz Step)

S₁₂ Parameter vs. Frequency

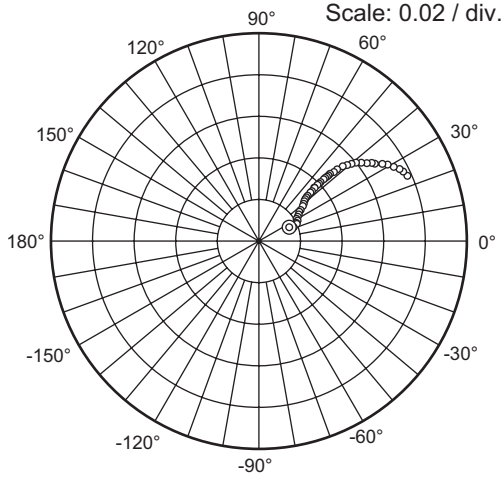

Condition: $V_{CE} = 3.6\text{ V}$, $I_C = 50\text{ mA}$, $Z_o = 50\ \Omega$
 100 to 3000 MHz (100 MHz Step)
 3200 to 6000 MHz (200 MHz Step)

S₂₂ Parameter vs. Frequency

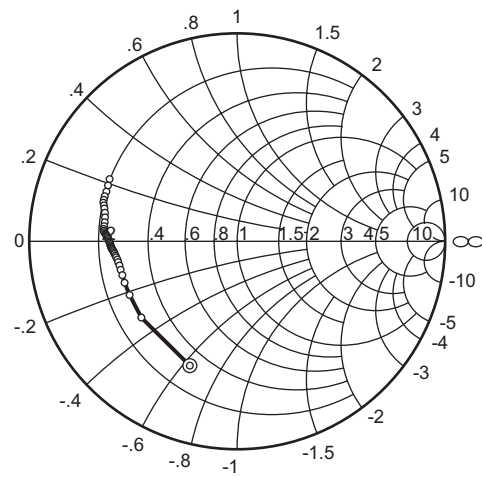

Condition: $V_{CE} = 3.6\text{ V}$, $I_C = 50\text{ mA}$, $Z_o = 50\ \Omega$
 100 to 3000 MHz (100 MHz Step)
 3200 to 6000 MHz (200 MHz Step)

S₁₁ Parameter vs. Frequency

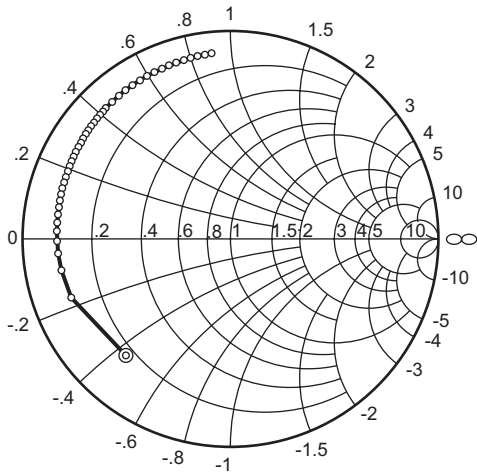

Condition: $V_{CE} = 3.6\text{ V}$, $I_C = 100\text{ mA}$, $Z_o = 50\ \Omega$
 100 to 3000 MHz (100 MHz Step)
 3200 to 6000 MHz (200 MHz Step)

S₂₁ Parameter vs. Frequency

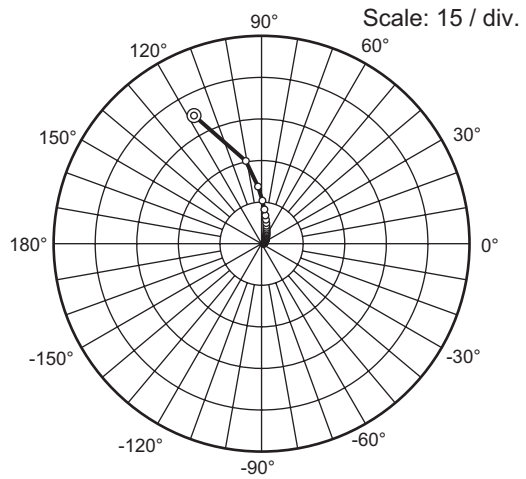

Condition: $V_{CE} = 3.6\text{ V}$, $I_C = 100\text{ mA}$, $Z_o = 50\ \Omega$
 100 to 3000 MHz (100 MHz Step)
 3200 to 6000 MHz (200 MHz Step)

S₁₂ Parameter vs. Frequency

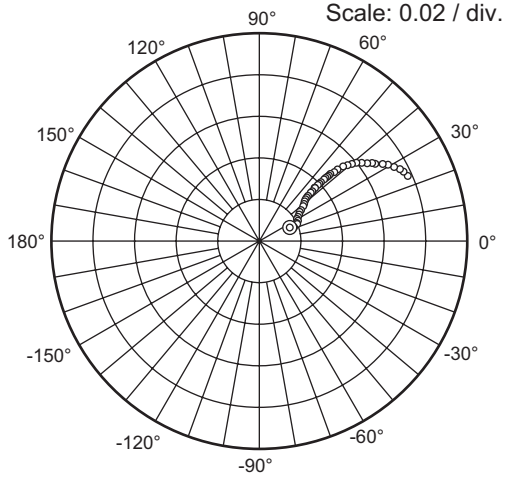

Condition: $V_{CE} = 3.6\text{ V}$, $I_C = 100\text{ mA}$, $Z_o = 50\ \Omega$
 100 to 3000 MHz (100 MHz Step)
 3200 to 6000 MHz (200 MHz Step)

S₂₂ Parameter vs. Frequency

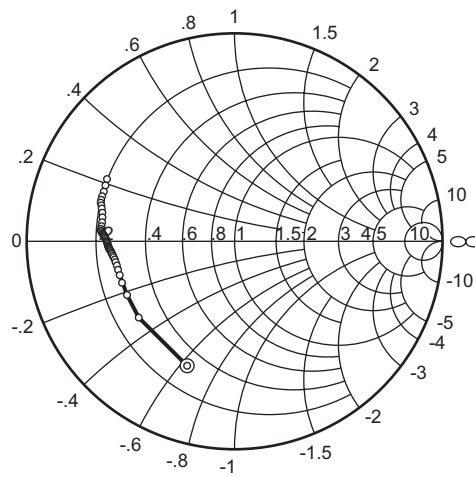

Condition: $V_{CE} = 3.6\text{ V}$, $I_C = 100\text{ mA}$, $Z_o = 50\ \Omega$
 100 to 3000 MHz (100 MHz Step)
 3200 to 6000 MHz (200 MHz Step)

S₁₁ Parameter vs. Frequency

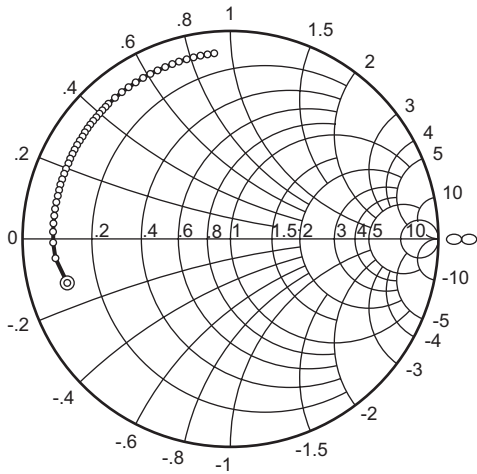

Condition: $V_{CE} = 3.6\text{ V}$, $I_C = 150\text{ mA}$, $Z_o = 50\ \Omega$
 100 to 3000 MHz (100 MHz Step)
 3200 to 6000 MHz (200 MHz Step)

S₂₁ Parameter vs. Frequency

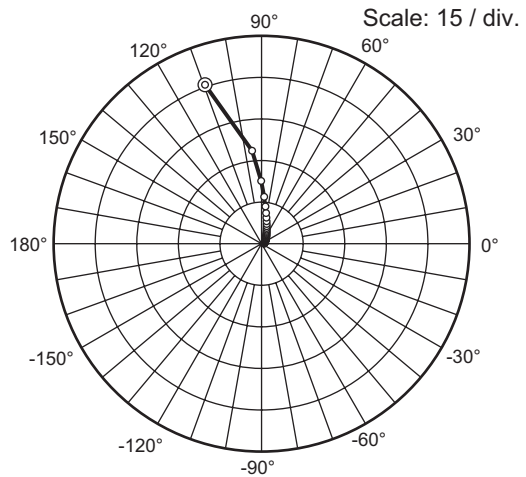

Condition: $V_{CE} = 3.6\text{ V}$, $I_C = 150\text{ mA}$, $Z_o = 50\ \Omega$
 100 to 3000 MHz (100 MHz Step)
 3200 to 6000 MHz (200 MHz Step)

S₁₂ Parameter vs. Frequency

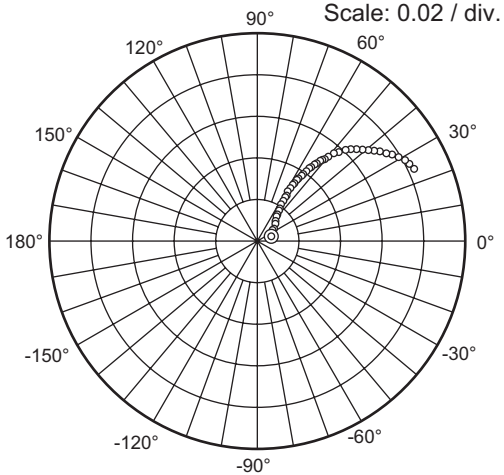

Condition: $V_{CE} = 3.6\text{ V}$, $I_C = 150\text{ mA}$, $Z_o = 50\ \Omega$
 100 to 3000 MHz (100 MHz Step)
 3200 to 6000 MHz (200 MHz Step)

S₂₂ Parameter vs. Frequency

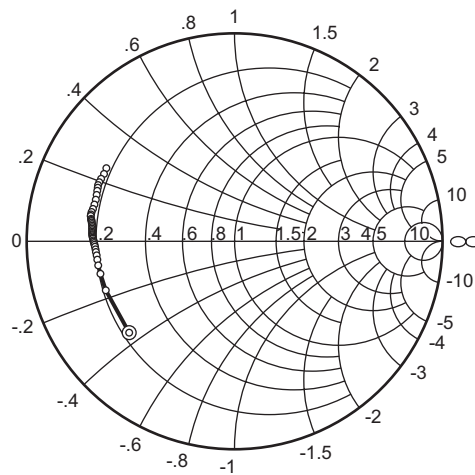

Condition: $V_{CE} = 3.6\text{ V}$, $I_C = 150\text{ mA}$, $Z_o = 50\ \Omega$
 100 to 3000 MHz (100 MHz Step)
 3200 to 6000 MHz (200 MHz Step)

S₁₁ Parameter vs. Frequency

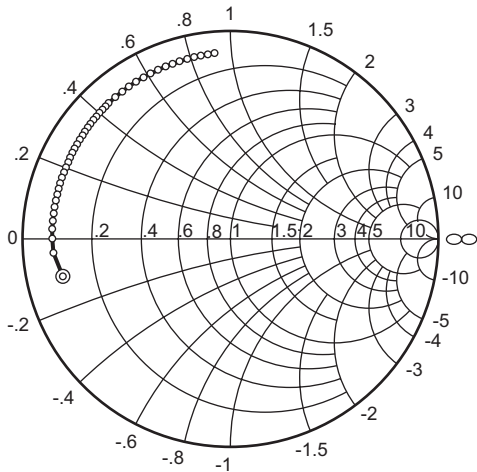

Condition: $V_{CE} = 3.6\text{ V}$, $I_C = 200\text{ mA}$, $Z_o = 50\ \Omega$
 100 to 3000 MHz (100 MHz Step)
 3200 to 6000 MHz (200 MHz Step)

S₂₁ Parameter vs. Frequency

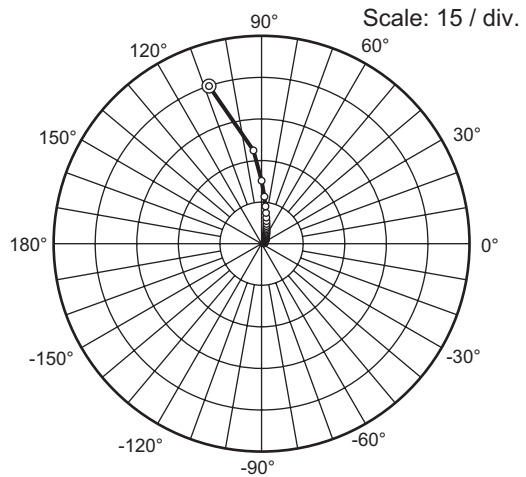

Condition: $V_{CE} = 3.6\text{ V}$, $I_C = 200\text{ mA}$, $Z_o = 50\ \Omega$
 100 to 3000 MHz (100 MHz Step)
 3200 to 6000 MHz (200 MHz Step)

S₁₂ Parameter vs. Frequency

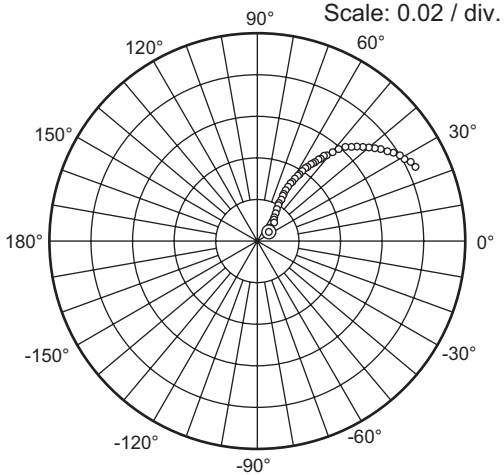

Condition: $V_{CE} = 3.6\text{ V}$, $I_C = 200\text{ mA}$, $Z_o = 50\ \Omega$
 100 to 3000 MHz (100 MHz Step)
 3200 to 6000 MHz (200 MHz Step)

S₂₂ Parameter vs. Frequency

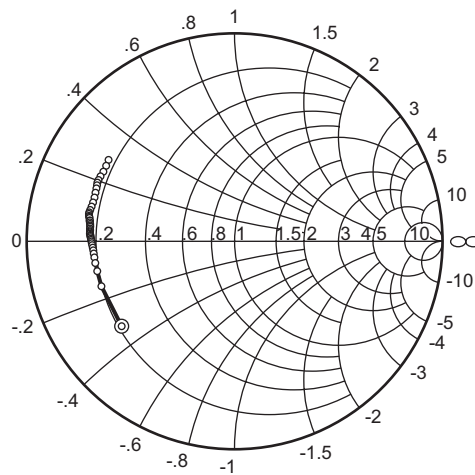

Condition: $V_{CE} = 3.6\text{ V}$, $I_C = 200\text{ mA}$, $Z_o = 50\ \Omega$
 100 to 3000 MHz (100 MHz Step)
 3200 to 6000 MHz (200 MHz Step)

S₁₁ Parameter vs. Frequency

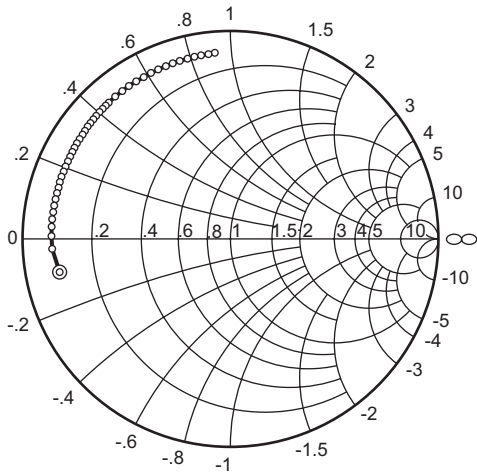

Condition: $V_{CE} = 3.6\text{ V}$, $I_C = 250\text{ mA}$, $Z_o = 50\ \Omega$
 100 to 3000 MHz (100 MHz Step)
 3200 to 6000 MHz (200 MHz Step)

S₂₁ Parameter vs. Frequency

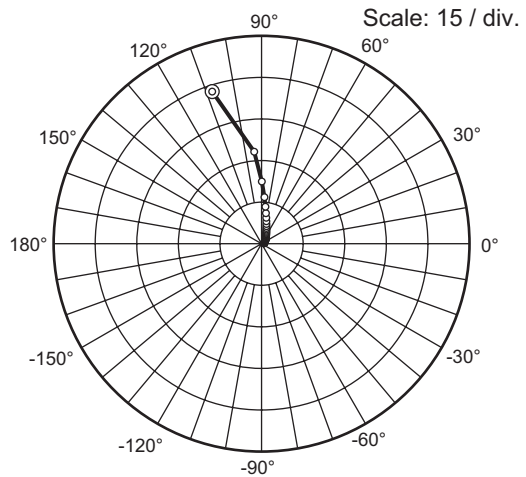

Condition: $V_{CE} = 3.6\text{ V}$, $I_C = 250\text{ mA}$, $Z_o = 50\ \Omega$
 100 to 3000 MHz (100 MHz Step)
 3200 to 6000 MHz (200 MHz Step)

S₁₂ Parameter vs. Frequency

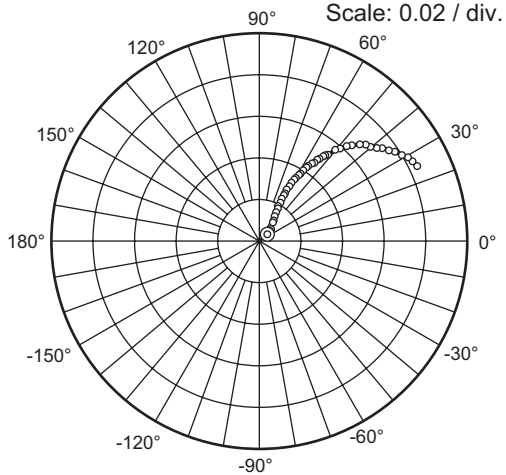

Condition: $V_{CE} = 3.6\text{ V}$, $I_C = 250\text{ mA}$, $Z_o = 50\ \Omega$
 100 to 3000 MHz (100 MHz Step)
 3200 to 6000 MHz (200 MHz Step)

S₂₂ Parameter vs. Frequency

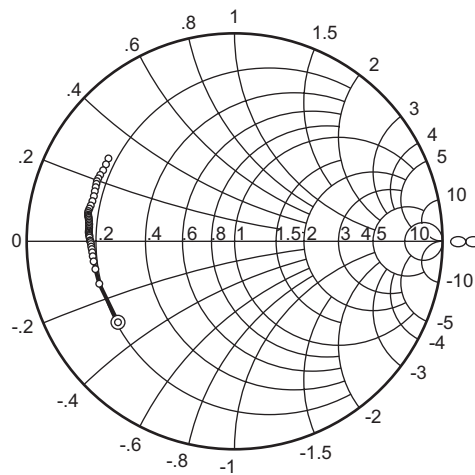

Condition: $V_{CE} = 3.6\text{ V}$, $I_C = 250\text{ mA}$, $Z_o = 50\ \Omega$
 100 to 3000 MHz (100 MHz Step)
 3200 to 6000 MHz (200 MHz Step)

S₁₁ Parameter vs. Frequency

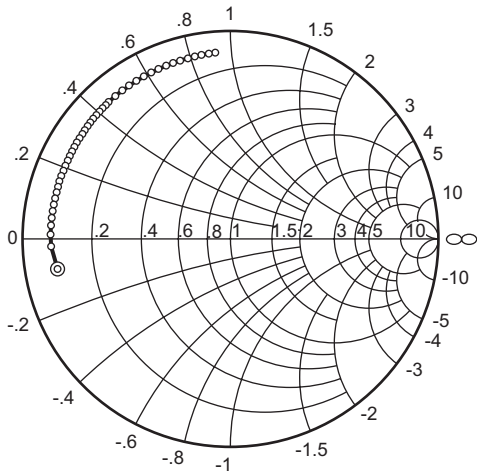

Condition: $V_{CE} = 3.6\text{ V}$, $I_C = 300\text{ mA}$, $Z_o = 50\ \Omega$
 100 to 3000 MHz (100 MHz Step)
 3200 to 6000 MHz (200 MHz Step)

S₂₁ Parameter vs. Frequency

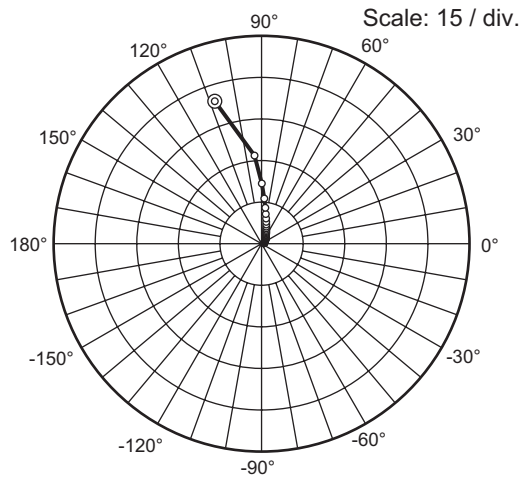

Condition: $V_{CE} = 3.6\text{ V}$, $I_C = 300\text{ mA}$, $Z_o = 50\ \Omega$
 100 to 3000 MHz (100 MHz Step)
 3200 to 6000 MHz (200 MHz Step)

S₁₂ Parameter vs. Frequency

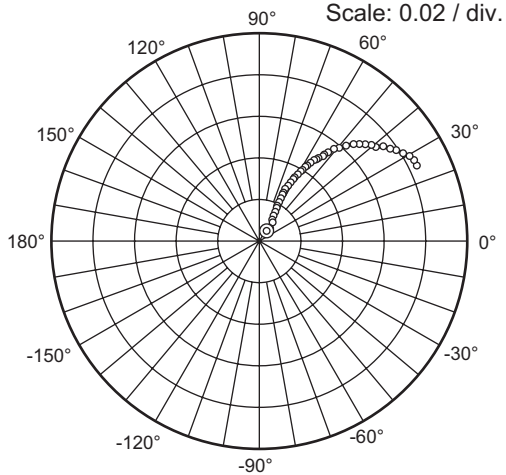

Condition: $V_{CE} = 3.6\text{ V}$, $I_C = 300\text{ mA}$, $Z_o = 50\ \Omega$
 100 to 3000 MHz (100 MHz Step)
 3200 to 6000 MHz (200 MHz Step)

S₂₂ Parameter vs. Frequency

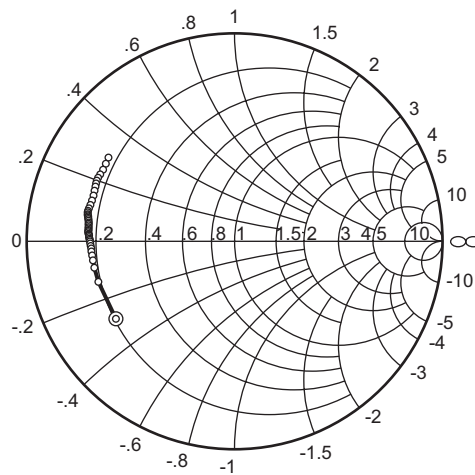

Condition: $V_{CE} = 3.6\text{ V}$, $I_C = 300\text{ mA}$, $Z_o = 50\ \Omega$
 100 to 3000 MHz (100 MHz Step)
 3200 to 6000 MHz (200 MHz Step)

S Parameter

(V_{CE} = 3 V, I_C = 50 mA, Z_O = 50 Ω)

f (MHz)	S11		S21		S12		S22	
	MAG	ANG	MAG	ANG	MAG	ANG	MAG	ANG
100	0.762	-132.1	49.76	117.1	0.0149	30.1	0.661	-112.5
200	0.821	-160.0	29.50	100.2	0.0178	21.5	0.604	-142.4
300	0.831	-169.8	20.12	93.1	0.0188	22.6	0.593	-154.3
400	0.835	-175.5	15.13	88.5	0.0193	24.1	0.590	-160.4
500	0.837	-179.5	12.08	85.1	0.0201	25.3	0.589	-164.3
600	0.838	177.2	10.02	82.2	0.0204	27.4	0.590	-166.9
700	0.839	174.4	8.55	79.6	0.0216	30.1	0.591	-169.0
800	0.840	171.8	7.44	77.2	0.0224	32.1	0.594	-170.6
900	0.841	169.4	6.56	75.0	0.0231	33.5	0.595	-172.0
1000	0.843	167.2	5.87	72.9	0.0244	35.6	0.598	-173.0
1100	0.845	165.1	5.30	71.0	0.0252	36.8	0.601	-173.9
1200	0.846	163.1	4.84	69.0	0.0268	38.5	0.604	-174.6
1300	0.846	161.1	4.43	67.1	0.0279	39.9	0.606	-175.3
1400	0.848	159.2	4.10	65.3	0.0290	41.2	0.609	-175.9
1500	0.849	157.3	3.80	63.5	0.0302	41.4	0.612	-176.5
1600	0.851	155.5	3.54	61.8	0.0316	41.9	0.614	-177.0
1700	0.852	153.8	3.31	60.1	0.0327	42.4	0.615	-177.4
1800	0.854	152.2	3.11	58.4	0.0340	43.1	0.617	-177.9
1900	0.855	150.5	2.94	56.7	0.0354	43.2	0.619	-178.3
2000	0.856	148.8	2.78	54.9	0.0367	43.7	0.620	-178.9
2100	0.857	147.1	2.63	53.3	0.0377	43.4	0.621	-179.4
2200	0.859	145.6	2.49	51.6	0.0392	43.9	0.623	180.0
2300	0.861	143.9	2.37	50.0	0.0402	43.8	0.625	179.4
2400	0.862	142.5	2.26	48.5	0.0417	43.6	0.627	178.8
2500	0.864	140.9	2.16	46.8	0.0429	43.7	0.630	178.3
2600	0.865	139.4	2.06	45.2	0.0440	43.5	0.632	177.7
2700	0.866	137.8	1.97	43.6	0.0452	43.4	0.636	177.1
2800	0.867	136.4	1.89	42.1	0.0466	43.0	0.639	176.6
2900	0.868	134.9	1.81	40.6	0.0476	42.8	0.642	176.3
3000	0.871	133.6	1.74	39.2	0.0491	42.7	0.645	175.9
3200	0.872	130.7	1.62	36.2	0.0515	42.1	0.650	175.4
3400	0.874	127.9	1.50	33.3	0.0539	41.5	0.652	174.8
3600	0.876	125.2	1.41	30.4	0.0562	40.5	0.652	174.0
3800	0.878	122.5	1.32	27.5	0.0582	39.3	0.651	172.8
4000	0.879	119.7	1.24	24.4	0.0604	38.1	0.651	171.0
4200	0.881	117.1	1.17	21.4	0.0624	37.0	0.653	169.0
4400	0.883	114.5	1.10	18.6	0.0642	35.5	0.658	167.1
4600	0.884	111.9	1.03	15.7	0.0659	34.3	0.664	165.4
4800	0.887	109.5	0.97	13.2	0.0678	33.3	0.670	164.2
5000	0.888	107.2	0.92	10.6	0.0703	31.6	0.676	163.2
5200	0.889	104.6	0.87	8.0	0.0719	30.4	0.678	162.1
5400	0.892	102.4	0.83	5.3	0.0740	28.5	0.678	160.6
5600	0.894	100.1	0.79	2.7	0.0758	27.0	0.678	158.5
5800	0.895	97.9	0.75	0.0	0.0772	25.3	0.682	156.0
6000	0.898	95.8	0.71	-2.6	0.0780	23.4	0.688	153.4

S Parameter

 $(V_{CE} = 3 \text{ V}, I_C = 100 \text{ mA}, Z_O = 50 \Omega)$

f (MHz)	S11		S21		S12		S22	
	MAG	ANG	MAG	ANG	MAG	ANG	MAG	ANG
100	0.808	-158.0	57.02	109.1	0.0093	38.0	0.671	-133.2
200	0.843	-170.6	32.12	96.4	0.0107	31.2	0.653	-155.6
300	0.847	-176.7	21.69	90.9	0.0118	35.0	0.651	-163.8
400	0.850	179.3	16.26	87.1	0.0136	36.4	0.653	-168.0
500	0.851	176.3	12.96	84.3	0.0146	39.5	0.653	-170.8
600	0.852	173.6	10.75	81.9	0.0158	41.9	0.654	-172.7
700	0.852	171.3	9.18	79.6	0.0177	45.2	0.655	-174.3
800	0.852	169.0	7.98	77.6	0.0186	48.5	0.657	-175.5
900	0.853	166.8	7.05	75.7	0.0201	49.7	0.658	-176.7
1000	0.854	164.8	6.31	73.9	0.0220	51.0	0.661	-177.5
1100	0.856	163.0	5.71	72.1	0.0234	51.2	0.663	-178.3
1200	0.857	161.1	5.21	70.4	0.0249	52.0	0.665	-178.9
1300	0.856	159.2	4.78	68.7	0.0264	52.8	0.666	-179.5
1400	0.858	157.4	4.42	67.1	0.0283	53.8	0.668	179.9
1500	0.858	155.6	4.10	65.4	0.0298	53.8	0.670	179.4
1600	0.859	153.9	3.83	63.9	0.0315	53.5	0.672	178.9
1700	0.861	152.2	3.59	62.4	0.0329	53.6	0.672	178.5
1800	0.862	150.7	3.37	60.9	0.0347	53.7	0.673	178.0
1900	0.863	149.0	3.18	59.3	0.0359	53.1	0.674	177.5
2000	0.863	147.4	3.01	57.7	0.0378	52.8	0.674	177.0
2100	0.863	145.7	2.86	56.2	0.0390	52.5	0.675	176.4
2200	0.866	144.3	2.71	54.7	0.0405	52.1	0.675	175.8
2300	0.867	142.7	2.59	53.2	0.0421	51.7	0.677	175.2
2400	0.868	141.2	2.46	51.8	0.0436	51.3	0.678	174.6
2500	0.869	139.7	2.36	50.2	0.0452	50.7	0.680	174.0
2600	0.870	138.2	2.25	48.8	0.0462	50.2	0.681	173.4
2700	0.871	136.7	2.16	47.3	0.0480	49.5	0.684	172.9
2800	0.872	135.2	2.07	45.8	0.0491	49.1	0.686	172.3
2900	0.873	133.8	1.99	44.5	0.0503	48.7	0.689	172.0
3000	0.875	132.5	1.91	43.2	0.0518	48.0	0.690	171.6
3200	0.876	129.7	1.78	40.4	0.0548	47.2	0.693	171.0
3400	0.877	126.9	1.66	37.7	0.0574	45.8	0.693	170.3
3600	0.878	124.2	1.56	35.0	0.0599	44.5	0.692	169.4
3800	0.879	121.6	1.46	32.2	0.0617	43.0	0.689	168.1
4000	0.880	118.8	1.38	29.3	0.0643	41.4	0.688	166.3
4200	0.882	116.3	1.30	26.4	0.0666	39.7	0.688	164.3
4400	0.883	113.7	1.22	23.7	0.0680	38.1	0.691	162.4
4600	0.884	111.1	1.15	21.0	0.0701	36.7	0.696	160.8
4800	0.886	108.7	1.09	18.6	0.0719	35.3	0.700	159.6
5000	0.888	106.4	1.04	16.1	0.0741	33.2	0.703	158.6
5200	0.889	103.9	0.99	13.6	0.0761	31.8	0.703	157.5
5400	0.891	101.7	0.94	11.0	0.0780	29.8	0.702	156.0
5600	0.893	99.6	0.89	8.4	0.0797	27.8	0.701	153.8
5800	0.894	97.3	0.85	5.7	0.0810	26.3	0.703	151.4
6000	0.897	95.2	0.81	3.3	0.0817	24.2	0.709	148.9

S Parameter

 $(V_{CE} = 3 \text{ V}, I_C = 150 \text{ mA}, Z_O = 50 \Omega)$

f (MHz)	S11		S21		S12		S22	
	MAG	ANG	MAG	ANG	MAG	ANG	MAG	ANG
100	0.827	-164.4	57.20	107.3	0.0082	31.8	0.686	-141.0
200	0.852	-174.0	32.75	95.0	0.0091	35.1	0.674	-160.1
300	0.856	-179.0	22.12	90.0	0.0105	37.7	0.675	-167.0
400	0.858	177.5	16.57	86.6	0.0120	43.6	0.676	-170.5
500	0.858	174.8	13.21	84.0	0.0133	48.2	0.676	-172.9
600	0.858	172.3	10.95	81.7	0.0143	50.9	0.677	-174.6
700	0.858	170.2	9.35	79.7	0.0166	53.1	0.679	-176.0
800	0.858	168.0	8.14	77.7	0.0181	55.1	0.680	-177.1
900	0.858	165.9	7.19	76.0	0.0195	55.8	0.681	-178.1
1000	0.860	164.0	6.44	74.2	0.0215	56.7	0.684	-178.9
1100	0.861	162.2	5.83	72.6	0.0229	57.6	0.686	-179.6
1200	0.862	160.4	5.32	70.9	0.0249	57.7	0.688	179.8
1300	0.861	158.5	4.88	69.3	0.0264	57.8	0.689	179.2
1400	0.862	156.8	4.52	67.7	0.0281	58.6	0.690	178.6
1500	0.862	155.0	4.19	66.1	0.0301	58.4	0.692	178.1
1600	0.864	153.3	3.92	64.7	0.0315	58.1	0.693	177.7
1700	0.865	151.6	3.67	63.2	0.0332	57.5	0.693	177.2
1800	0.866	150.1	3.45	61.8	0.0348	57.2	0.695	176.7
1900	0.867	148.5	3.26	60.2	0.0364	56.4	0.695	176.3
2000	0.867	146.8	3.09	58.7	0.0381	56.2	0.695	175.7
2100	0.867	145.2	2.93	57.2	0.0397	55.6	0.695	175.1
2200	0.869	143.8	2.78	55.7	0.0413	55.2	0.696	174.5
2300	0.871	142.2	2.65	54.3	0.0428	54.7	0.697	173.9
2400	0.871	140.8	2.53	52.9	0.0444	53.8	0.698	173.3
2500	0.873	139.3	2.42	51.5	0.0458	53.0	0.700	172.7
2600	0.873	137.8	2.31	50.0	0.0470	52.8	0.701	172.1
2700	0.874	136.3	2.21	48.6	0.0485	51.9	0.703	171.6
2800	0.874	134.8	2.12	47.2	0.0502	51.3	0.705	171.1
2900	0.875	133.4	2.04	45.9	0.0515	50.9	0.707	170.7
3000	0.877	132.1	1.97	44.6	0.0529	50.0	0.709	170.3
3200	0.878	129.3	1.83	41.9	0.0558	49.0	0.711	169.6
3400	0.879	126.5	1.71	39.3	0.0585	47.5	0.711	169.0
3600	0.881	123.9	1.60	36.6	0.0612	46.2	0.709	168.0
3800	0.881	121.2	1.51	33.9	0.0633	44.5	0.706	166.7
4000	0.882	118.5	1.42	31.1	0.0656	42.8	0.704	164.9
4200	0.884	115.9	1.34	28.2	0.0679	41.0	0.704	162.9
4400	0.885	113.4	1.26	25.6	0.0696	39.3	0.707	161.0
4600	0.886	110.8	1.19	22.9	0.0715	37.6	0.711	159.3
4800	0.887	108.4	1.12	20.6	0.0732	36.2	0.714	158.2
5000	0.889	106.2	1.07	18.2	0.0757	34.1	0.717	157.2
5200	0.889	103.7	1.02	15.7	0.0777	32.6	0.717	156.0
5400	0.892	101.5	0.97	13.1	0.0797	30.5	0.715	154.4
5600	0.893	99.3	0.93	10.6	0.0811	28.5	0.713	152.3
5800	0.894	97.1	0.88	8.0	0.0825	26.7	0.716	149.9
6000	0.897	95.0	0.84	5.5	0.0832	24.6	0.721	147.4

S Parameter

 $(V_{CE} = 3 \text{ V}, I_C = 200 \text{ mA}, Z_O = 50 \Omega)$

f (MHz)	S11		S21		S12		S22	
	MAG	ANG	MAG	ANG	MAG	ANG	MAG	ANG
100	0.840	-167.2	55.66	106.6	0.0060	37.6	0.689	-145.0
200	0.859	-176.0	32.64	94.3	0.0071	42.3	0.685	-162.3
300	0.860	179.7	22.09	89.6	0.0091	45.5	0.686	-168.6
400	0.861	176.6	16.56	86.4	0.0116	51.2	0.687	-171.7
500	0.862	174.0	13.20	83.9	0.0127	51.6	0.688	-173.9
600	0.862	171.7	10.95	81.7	0.0139	56.1	0.689	-175.5
700	0.862	169.6	9.35	79.7	0.0160	57.3	0.690	-176.8
800	0.862	167.5	8.14	77.8	0.0176	58.7	0.692	-177.9
900	0.863	165.5	7.20	76.1	0.0195	59.3	0.693	-178.8
1000	0.863	163.6	6.45	74.4	0.0212	60.3	0.696	-179.6
1100	0.865	161.8	5.83	72.8	0.0229	61.2	0.697	179.7
1200	0.865	160.0	5.32	71.2	0.0248	60.5	0.699	179.2
1300	0.864	158.2	4.89	69.6	0.0264	60.4	0.700	178.6
1400	0.865	156.4	4.52	68.1	0.0284	61.1	0.701	178.0
1500	0.865	154.7	4.20	66.5	0.0302	60.5	0.702	177.5
1600	0.867	153.0	3.92	65.1	0.0320	60.4	0.704	177.1
1700	0.868	151.4	3.68	63.7	0.0333	59.6	0.705	176.6
1800	0.869	149.8	3.46	62.2	0.0350	59.1	0.705	176.2
1900	0.869	148.2	3.27	60.7	0.0367	58.7	0.705	175.7
2000	0.870	146.6	3.09	59.2	0.0384	57.7	0.706	175.1
2100	0.870	145.0	2.94	57.7	0.0399	57.1	0.706	174.5
2200	0.872	143.5	2.79	56.3	0.0416	56.7	0.706	173.9
2300	0.873	141.9	2.66	54.9	0.0431	56.1	0.707	173.3
2400	0.874	140.5	2.54	53.5	0.0446	55.1	0.708	172.7
2500	0.875	139.0	2.42	52.1	0.0464	54.5	0.710	172.1
2600	0.875	137.5	2.32	50.7	0.0475	53.9	0.711	171.5
2700	0.876	136.1	2.22	49.2	0.0492	53.3	0.713	171.0
2800	0.877	134.6	2.13	47.9	0.0507	52.4	0.715	170.5
2900	0.878	133.2	2.05	46.6	0.0519	51.9	0.717	170.1
3000	0.880	131.9	1.98	45.3	0.0536	51.2	0.718	169.7
3200	0.880	129.1	1.84	42.7	0.0562	49.8	0.721	169.0
3400	0.881	126.3	1.71	40.1	0.0590	48.3	0.720	168.3
3600	0.882	123.7	1.61	37.5	0.0617	46.9	0.718	167.4
3800	0.883	121.0	1.52	34.8	0.0640	45.3	0.715	166.0
4000	0.883	118.3	1.43	31.9	0.0662	43.4	0.713	164.2
4200	0.885	115.7	1.35	29.2	0.0684	41.6	0.713	162.2
4400	0.886	113.2	1.27	26.6	0.0700	39.9	0.716	160.3
4600	0.887	110.6	1.20	23.9	0.0721	38.1	0.719	158.7
4800	0.889	108.3	1.13	21.6	0.0740	36.7	0.722	157.5
5000	0.890	106.0	1.08	19.2	0.0764	34.5	0.725	156.4
5200	0.890	103.5	1.03	16.8	0.0784	33.1	0.724	155.3
5400	0.892	101.3	0.98	14.2	0.0804	30.9	0.723	153.7
5600	0.894	99.2	0.94	11.7	0.0819	28.8	0.721	151.6
5800	0.895	96.9	0.89	9.1	0.0831	27.2	0.723	149.2
6000	0.898	94.9	0.85	6.7	0.0839	25.1	0.728	146.7

S Parameter

 $(V_{CE} = 3 \text{ V}, I_C = 250 \text{ mA}, Z_O = 50 \Omega)$

f (MHz)	S11		S21		S12		S22	
	MAG	ANG	MAG	ANG	MAG	ANG	MAG	ANG
100	0.849	-169.2	52.97	106.7	0.0058	55.3	0.693	-147.5
200	0.865	-177.1	31.84	94.0	0.0066	42.8	0.691	-163.7
300	0.865	178.8	21.70	89.5	0.0086	46.1	0.692	-169.5
400	0.865	175.9	16.30	86.3	0.0104	51.2	0.695	-172.6
500	0.866	173.5	13.01	83.9	0.0120	57.3	0.695	-174.6
600	0.865	171.3	10.79	81.8	0.0136	59.3	0.696	-176.1
700	0.865	169.2	9.22	79.8	0.0158	60.8	0.697	-177.3
800	0.865	167.1	8.03	77.9	0.0173	61.4	0.699	-178.3
900	0.866	165.1	7.10	76.3	0.0193	61.9	0.700	-179.2
1000	0.866	163.3	6.36	74.6	0.0213	63.1	0.702	180.0
1100	0.868	161.5	5.76	73.0	0.0227	62.4	0.703	179.3
1200	0.868	159.7	5.25	71.4	0.0247	62.8	0.705	178.8
1300	0.867	157.9	4.82	69.8	0.0263	62.2	0.707	178.2
1400	0.869	156.2	4.47	68.3	0.0283	62.0	0.707	177.6
1500	0.868	154.4	4.15	66.7	0.0302	61.8	0.708	177.2
1600	0.870	152.8	3.88	65.4	0.0319	61.3	0.710	176.8
1700	0.871	151.2	3.63	63.9	0.0336	60.9	0.711	176.3
1800	0.872	149.6	3.42	62.5	0.0352	60.0	0.711	175.8
1900	0.872	148.0	3.23	61.0	0.0368	59.7	0.711	175.3
2000	0.872	146.4	3.06	59.5	0.0387	59.0	0.711	174.8
2100	0.873	144.8	2.90	58.0	0.0403	58.2	0.712	174.2
2200	0.874	143.4	2.76	56.6	0.0419	57.7	0.713	173.6
2300	0.876	141.8	2.63	55.2	0.0434	56.9	0.713	173.0
2400	0.876	140.4	2.51	53.8	0.0449	56.2	0.714	172.4
2500	0.878	138.8	2.40	52.4	0.0466	55.4	0.716	171.8
2600	0.877	137.4	2.29	51.0	0.0477	54.7	0.717	171.2
2700	0.879	135.9	2.20	49.6	0.0496	53.8	0.719	170.6
2800	0.879	134.5	2.11	48.2	0.0507	53.3	0.721	170.1
2900	0.880	133.1	2.03	46.9	0.0522	52.6	0.723	169.8
3000	0.882	131.7	1.95	45.7	0.0539	51.7	0.724	169.3
3200	0.883	129.0	1.82	43.1	0.0567	50.4	0.726	168.7
3400	0.883	126.2	1.70	40.5	0.0595	48.9	0.726	168.0
3600	0.884	123.6	1.59	37.9	0.0622	47.3	0.724	167.0
3800	0.885	120.9	1.50	35.2	0.0643	45.7	0.720	165.7
4000	0.885	118.2	1.41	32.4	0.0665	43.9	0.718	163.8
4200	0.887	115.6	1.33	29.6	0.0690	42.0	0.718	161.9
4400	0.888	113.1	1.26	27.1	0.0707	40.2	0.721	159.9
4600	0.889	110.5	1.19	24.4	0.0726	38.6	0.724	158.3
4800	0.890	108.2	1.12	22.1	0.0745	37.0	0.727	157.1
5000	0.891	105.9	1.07	19.8	0.0767	35.0	0.730	156.1
5200	0.892	103.4	1.02	17.4	0.0788	33.3	0.729	154.9
5400	0.894	101.2	0.97	14.8	0.0805	31.2	0.727	153.3
5600	0.895	99.1	0.93	12.3	0.0824	29.2	0.725	151.2
5800	0.896	96.8	0.88	9.7	0.0836	27.4	0.727	148.8
6000	0.899	94.8	0.84	7.4	0.0845	25.3	0.732	146.3

S Parameter

 $(V_{CE} = 3 \text{ V}, I_C = 300 \text{ mA}, Z_O = 50 \Omega)$

f (MHz)	S11		S21		S12		S22	
	MAG	ANG	MAG	ANG	MAG	ANG	MAG	ANG
100	0.853	-170.5	49.25	107.2	0.004	60.4	0.690	-149.7
200	0.871	-178.1	29.97	94.3	0.006	40.8	0.693	-164.9
300	0.870	178.2	20.77	89.6	0.008	51.2	0.696	-170.3
400	0.870	175.4	15.70	86.4	0.011	53.2	0.698	-173.2
500	0.870	173.1	12.55	84.0	0.012	58.4	0.699	-175.1
600	0.870	170.9	10.43	81.9	0.014	61.2	0.700	-176.5
700	0.870	168.9	8.91	79.9	0.016	61.3	0.701	-177.7
800	0.869	166.9	7.76	78.0	0.018	63.2	0.702	-178.7
900	0.870	164.9	6.87	76.4	0.019	64.0	0.704	-179.6
1000	0.870	163.1	6.16	74.7	0.021	65.0	0.706	179.6
1100	0.871	161.3	5.57	73.1	0.023	63.8	0.707	179.0
1200	0.872	159.5	5.09	71.5	0.025	63.5	0.709	178.5
1300	0.871	157.7	4.67	70.0	0.027	63.7	0.711	178.0
1400	0.872	156.0	4.33	68.4	0.028	62.9	0.711	177.3
1500	0.872	154.3	4.02	66.9	0.030	62.4	0.711	176.9
1600	0.873	152.6	3.76	65.5	0.032	62.3	0.714	176.6
1700	0.874	151.0	3.52	64.1	0.034	61.4	0.715	176.0
1800	0.875	149.5	3.31	62.6	0.035	61.2	0.715	175.5
1900	0.876	147.9	3.13	61.1	0.037	60.4	0.715	175.1
2000	0.876	146.3	2.97	59.7	0.039	59.6	0.715	174.6
2100	0.876	144.7	2.82	58.2	0.040	58.8	0.716	174.0
2200	0.878	143.2	2.67	56.7	0.042	58.4	0.716	173.4
2300	0.879	141.7	2.55	55.4	0.043	57.7	0.717	172.8
2400	0.879	140.3	2.43	54.0	0.045	56.8	0.717	172.2
2500	0.881	138.7	2.33	52.6	0.047	56.0	0.719	171.6
2600	0.881	137.3	2.22	51.1	0.048	55.4	0.721	171.0
2700	0.882	135.8	2.13	49.7	0.050	54.3	0.723	170.4
2800	0.882	134.3	2.05	48.4	0.051	53.9	0.724	169.9
2900	0.883	132.9	1.97	47.1	0.052	53.1	0.726	169.6
3000	0.885	131.6	1.90	45.9	0.054	52.2	0.728	169.1
3200	0.885	128.9	1.76	43.3	0.057	50.8	0.730	168.5
3400	0.886	126.1	1.65	40.7	0.060	49.5	0.729	167.8
3600	0.887	123.5	1.55	38.1	0.062	47.6	0.727	166.8
3800	0.887	120.8	1.46	35.4	0.065	46.1	0.724	165.4
4000	0.887	118.1	1.37	32.6	0.067	44.2	0.722	163.6
4200	0.889	115.5	1.30	29.9	0.069	42.4	0.722	161.7
4400	0.890	113.0	1.22	27.3	0.071	40.5	0.725	159.7
4600	0.891	110.4	1.15	24.7	0.073	38.8	0.728	158.1
4800	0.892	108.1	1.09	22.4	0.075	37.5	0.731	156.9
5000	0.893	105.8	1.04	20.1	0.077	35.4	0.733	155.9
5200	0.894	103.3	0.99	17.7	0.079	33.6	0.732	154.7
5400	0.896	101.1	0.94	15.2	0.081	31.5	0.731	153.1
5600	0.897	99.0	0.90	12.7	0.082	29.5	0.728	151.0
5800	0.898	96.7	0.86	10.1	0.084	27.5	0.730	148.5
6000	0.901	94.7	0.82	7.7	0.085	25.5	0.736	146.1

S Parameter

 $(V_{CE} = 3.3 \text{ V}, I_C = 50 \text{ mA}, Z_O = 50 \Omega)$

f (MHz)	S11		S21		S12		S22	
	MAG	ANG	MAG	ANG	MAG	ANG	MAG	ANG
100	0.759	-131.6	51.08	117.5	0.017	41.9	0.649	-111.6
200	0.818	-159.8	29.99	100.5	0.017	21.4	0.595	-142.0
300	0.828	-169.6	20.43	93.3	0.018	23.0	0.584	-153.9
400	0.833	-175.3	15.36	88.7	0.019	22.4	0.583	-160.0
500	0.836	-179.3	12.25	85.2	0.020	26.1	0.582	-163.9
600	0.837	177.4	10.16	82.2	0.020	27.9	0.583	-166.6
700	0.838	174.5	8.67	79.6	0.022	29.9	0.584	-168.6
800	0.839	171.9	7.54	77.2	0.022	32.1	0.587	-170.3
900	0.840	169.5	6.65	75.0	0.023	34.3	0.588	-171.6
1000	0.842	167.3	5.95	72.9	0.024	36.1	0.592	-172.7
1100	0.844	165.2	5.38	70.9	0.025	36.5	0.595	-173.5
1200	0.845	163.2	4.90	68.9	0.027	38.7	0.598	-174.3
1300	0.845	161.2	4.49	67.0	0.028	39.7	0.600	-174.9
1400	0.847	159.3	4.15	65.2	0.029	40.8	0.603	-175.6
1500	0.848	157.4	3.85	63.4	0.030	41.2	0.605	-176.1
1600	0.850	155.6	3.59	61.7	0.031	42.3	0.608	-176.7
1700	0.851	153.9	3.36	60.0	0.033	42.7	0.609	-177.0
1800	0.853	152.3	3.15	58.3	0.034	43.4	0.612	-177.5
1900	0.855	150.5	2.98	56.6	0.035	43.4	0.613	-177.9
2000	0.856	148.9	2.81	54.8	0.037	43.8	0.615	-178.5
2100	0.856	147.2	2.66	53.1	0.038	43.9	0.616	-179.1
2200	0.859	145.7	2.53	51.5	0.039	44.0	0.617	-179.6
2300	0.860	144.0	2.40	49.9	0.040	43.9	0.619	179.9
2400	0.862	142.5	2.29	48.3	0.041	43.5	0.622	179.2
2500	0.863	141.0	2.19	46.7	0.043	43.8	0.624	178.6
2600	0.864	139.5	2.09	45.0	0.044	43.8	0.627	178.1
2700	0.866	137.9	2.00	43.4	0.045	43.5	0.631	177.6
2800	0.867	136.4	1.91	41.9	0.047	43.3	0.634	177.1
2900	0.868	135.0	1.84	40.4	0.047	43.0	0.637	176.7
3000	0.870	133.6	1.77	39.0	0.049	42.5	0.640	176.3
3200	0.872	130.8	1.64	36.0	0.051	42.2	0.645	175.8
3400	0.873	127.9	1.52	33.1	0.054	41.6	0.647	175.3
3600	0.876	125.3	1.42	30.2	0.056	40.6	0.648	174.4
3800	0.877	122.5	1.34	27.2	0.058	39.7	0.647	173.2
4000	0.878	119.7	1.25	24.2	0.060	38.6	0.647	171.4
4200	0.881	117.1	1.18	21.1	0.062	37.2	0.649	169.5
4400	0.883	114.6	1.11	18.3	0.064	35.8	0.654	167.5
4600	0.884	111.9	1.04	15.4	0.066	34.5	0.661	165.8
4800	0.886	109.5	0.98	12.9	0.068	33.6	0.667	164.6
5000	0.888	107.2	0.93	10.3	0.070	31.8	0.673	163.6
5200	0.890	104.7	0.88	7.7	0.072	30.4	0.675	162.5
5400	0.892	102.4	0.84	5.1	0.074	28.7	0.676	161.0
5600	0.894	100.2	0.80	2.4	0.076	27.0	0.675	158.9
5800	0.896	97.9	0.76	-0.3	0.077	25.5	0.679	156.4
6000	0.898	95.8	0.72	-2.9	0.078	23.6	0.686	153.8

S Parameter

 $(V_{CE} = 3.3 \text{ V}, I_C = 100 \text{ mA}, Z_0 = 50 \Omega)$

f (MHz)	S11		S21		S12		S22	
	MAG	ANG	MAG	ANG	MAG	ANG	MAG	ANG
100	0.800	-158.5	58.96	110.0	0.011	36.5	0.661	-132.4
200	0.839	-170.4	32.67	96.8	0.011	27.3	0.647	-155.2
300	0.846	-176.6	22.02	91.1	0.012	30.4	0.645	-163.5
400	0.849	179.5	16.50	87.3	0.014	37.9	0.646	-167.8
500	0.850	176.4	13.15	84.5	0.015	41.2	0.647	-170.6
600	0.851	173.7	10.90	82.0	0.016	43.8	0.648	-172.5
700	0.851	171.4	9.30	79.7	0.018	45.5	0.649	-174.0
800	0.852	169.1	8.09	77.6	0.019	47.7	0.651	-175.3
900	0.852	166.9	7.15	75.7	0.020	49.9	0.652	-176.4
1000	0.853	164.9	6.40	73.9	0.022	50.4	0.655	-177.3
1100	0.855	163.0	5.79	72.1	0.023	51.7	0.657	-178.0
1200	0.856	161.2	5.28	70.4	0.025	52.4	0.660	-178.7
1300	0.855	159.3	4.84	68.7	0.027	52.9	0.661	-179.3
1400	0.857	157.5	4.48	67.0	0.028	54.0	0.663	-179.9
1500	0.857	155.7	4.16	65.4	0.030	54.5	0.665	179.6
1600	0.859	153.9	3.88	63.8	0.031	53.9	0.666	179.1
1700	0.860	152.3	3.63	62.4	0.033	53.4	0.666	178.7
1800	0.860	150.7	3.42	60.8	0.034	53.6	0.668	178.2
1900	0.862	149.0	3.23	59.2	0.036	53.1	0.668	177.8
2000	0.863	147.4	3.05	57.6	0.038	52.8	0.669	177.2
2100	0.863	145.8	2.89	56.1	0.039	52.6	0.669	176.6
2200	0.865	144.3	2.75	54.5	0.041	52.5	0.671	176.0
2300	0.866	142.7	2.62	53.1	0.042	52.0	0.671	175.5
2400	0.867	141.3	2.50	51.6	0.043	51.1	0.673	174.9
2500	0.869	139.7	2.39	50.1	0.045	50.6	0.675	174.2
2600	0.869	138.3	2.28	48.6	0.046	50.1	0.676	173.6
2700	0.870	136.7	2.19	47.1	0.048	49.9	0.679	173.1
2800	0.871	135.3	2.10	45.7	0.049	49.3	0.681	172.6
2900	0.872	133.9	2.01	44.3	0.050	48.7	0.684	172.3
3000	0.874	132.5	1.94	43.0	0.052	48.0	0.685	171.9
3200	0.875	129.7	1.80	40.2	0.054	47.0	0.689	171.3
3400	0.876	126.9	1.68	37.5	0.057	46.0	0.689	170.6
3600	0.878	124.3	1.57	34.8	0.060	44.7	0.688	169.7
3800	0.879	121.6	1.48	32.0	0.062	42.9	0.685	168.4
4000	0.880	118.8	1.39	29.0	0.064	41.6	0.683	166.6
4200	0.882	116.3	1.31	26.2	0.066	39.9	0.684	164.6
4400	0.883	113.7	1.24	23.5	0.068	38.2	0.687	162.7
4600	0.884	111.1	1.17	20.7	0.070	36.7	0.692	161.1
4800	0.886	108.8	1.10	18.3	0.072	35.2	0.696	159.9
5000	0.888	106.5	1.05	15.8	0.074	33.4	0.700	158.9
5200	0.889	104.0	1.00	13.4	0.076	31.9	0.700	157.8
5400	0.891	101.8	0.95	10.7	0.078	29.9	0.699	156.2
5600	0.893	99.6	0.90	8.1	0.080	28.0	0.697	154.2
5800	0.894	97.3	0.86	5.5	0.081	26.3	0.700	151.7
6000	0.897	95.3	0.82	3.0	0.082	24.2	0.706	149.2

S Parameter

 $(V_{CE} = 3.3 \text{ V}, I_C = 150 \text{ mA}, Z_O = 50 \Omega)$

f (MHz)	S11		S21		S12		S22	
	MAG	ANG	MAG	ANG	MAG	ANG	MAG	ANG
100	0.820	-164.5	59.44	108.3	0.008	30.1	0.680	-140.0
200	0.850	-173.9	33.34	95.4	0.008	30.6	0.669	-159.6
300	0.854	-178.9	22.44	90.2	0.011	39.6	0.669	-166.6
400	0.856	177.6	16.80	86.8	0.012	45.1	0.670	-170.3
500	0.856	174.9	13.39	84.1	0.013	47.5	0.671	-172.6
600	0.856	172.5	11.10	81.8	0.015	50.6	0.672	-174.3
700	0.857	170.2	9.48	79.7	0.017	52.6	0.673	-175.8
800	0.857	168.1	8.25	77.7	0.018	54.9	0.675	-176.9
900	0.857	166.0	7.29	76.0	0.020	56.3	0.676	-177.9
1000	0.858	164.1	6.53	74.2	0.022	57.2	0.679	-178.7
1100	0.860	162.3	5.90	72.6	0.023	57.4	0.681	-179.4
1200	0.861	160.4	5.39	70.9	0.025	57.6	0.683	180.0
1300	0.860	158.6	4.94	69.3	0.027	58.0	0.683	179.4
1400	0.861	156.8	4.57	67.7	0.028	58.8	0.685	178.8
1500	0.861	155.0	4.25	66.1	0.030	58.1	0.687	178.3
1600	0.863	153.4	3.97	64.6	0.032	57.8	0.688	177.8
1700	0.864	151.7	3.72	63.2	0.033	57.4	0.689	177.4
1800	0.865	150.2	3.50	61.7	0.035	57.4	0.690	176.9
1900	0.866	148.5	3.30	60.2	0.036	56.4	0.690	176.5
2000	0.866	146.9	3.13	58.6	0.038	56.4	0.690	175.9
2100	0.866	145.3	2.96	57.1	0.040	55.7	0.691	175.3
2200	0.868	143.8	2.82	55.7	0.041	55.3	0.692	174.7
2300	0.870	142.2	2.68	54.2	0.043	54.7	0.692	174.1
2400	0.870	140.8	2.56	52.8	0.044	54.0	0.693	173.5
2500	0.872	139.3	2.45	51.3	0.046	53.2	0.695	172.9
2600	0.872	137.8	2.34	49.9	0.047	52.8	0.696	172.3
2700	0.873	136.3	2.24	48.4	0.049	52.2	0.699	171.8
2800	0.874	134.9	2.15	47.1	0.050	51.2	0.701	171.3
2900	0.875	133.5	2.07	45.7	0.051	50.6	0.703	170.9
3000	0.877	132.1	1.99	44.4	0.053	50.0	0.704	170.5
3200	0.878	129.3	1.85	41.8	0.056	48.8	0.707	169.9
3400	0.878	126.5	1.73	39.1	0.058	47.6	0.707	169.2
3600	0.880	123.9	1.62	36.4	0.061	46.0	0.705	168.2
3800	0.881	121.3	1.53	33.7	0.063	44.5	0.702	166.9
4000	0.881	118.5	1.44	30.9	0.066	42.8	0.700	165.1
4200	0.883	115.9	1.35	28.0	0.068	40.9	0.701	163.1
4400	0.884	113.4	1.28	25.4	0.069	39.3	0.704	161.2
4600	0.885	110.8	1.20	22.7	0.071	37.6	0.707	159.6
4800	0.887	108.5	1.14	20.4	0.073	36.1	0.711	158.4
5000	0.888	106.2	1.08	17.9	0.076	34.2	0.714	157.4
5200	0.889	103.7	1.03	15.5	0.077	32.6	0.713	156.2
5400	0.891	101.5	0.98	12.9	0.079	30.6	0.712	154.7
5600	0.893	99.3	0.94	10.3	0.081	28.6	0.710	152.6
5800	0.894	97.1	0.89	7.7	0.082	26.8	0.712	150.1
6000	0.897	95.0	0.85	5.3	0.083	24.7	0.718	147.6

S Parameter

 $(V_{CE} = 3.3 \text{ V}, I_C = 200 \text{ mA}, Z_O = 50 \Omega)$

f (MHz)	S11		S21		S12		S22	
	MAG	ANG	MAG	ANG	MAG	ANG	MAG	ANG
100	0.833	-167.5	58.17	107.4	0.006	32.3	0.687	-143.9
200	0.856	-175.7	33.32	94.6	0.007	33.4	0.680	-161.8
300	0.858	179.8	22.45	89.8	0.009	45.3	0.681	-168.2
400	0.860	176.6	16.81	86.5	0.011	49.3	0.683	-171.5
500	0.861	174.1	13.40	84.0	0.013	52.5	0.684	-173.7
600	0.861	171.8	11.11	81.8	0.014	56.0	0.685	-175.3
700	0.861	169.6	9.48	79.7	0.016	57.6	0.686	-176.6
800	0.861	167.5	8.25	77.8	0.018	58.9	0.688	-177.7
900	0.861	165.5	7.30	76.1	0.020	59.0	0.688	-178.7
1000	0.862	163.7	6.54	74.4	0.021	60.7	0.691	-179.4
1100	0.864	161.8	5.91	72.8	0.023	60.3	0.693	179.9
1200	0.864	160.0	5.40	71.2	0.025	60.4	0.695	179.3
1300	0.863	158.2	4.95	69.6	0.026	60.3	0.696	178.7
1400	0.864	156.5	4.59	68.0	0.029	60.8	0.697	178.1
1500	0.864	154.7	4.26	66.5	0.030	60.6	0.698	177.7
1600	0.866	153.0	3.98	65.0	0.032	59.7	0.700	177.2
1700	0.867	151.4	3.73	63.6	0.033	59.4	0.700	176.8
1800	0.868	149.9	3.51	62.2	0.035	58.9	0.701	176.3
1900	0.869	148.2	3.31	60.7	0.037	58.5	0.701	175.9
2000	0.869	146.6	3.14	59.1	0.038	57.7	0.701	175.3
2100	0.869	145.0	2.98	57.7	0.040	57.2	0.702	174.7
2200	0.871	143.6	2.83	56.2	0.042	56.6	0.702	174.1
2300	0.872	142.0	2.70	54.8	0.043	56.0	0.703	173.5
2400	0.873	140.6	2.57	53.4	0.045	55.2	0.704	172.9
2500	0.874	139.1	2.46	52.0	0.046	54.3	0.706	172.3
2600	0.874	137.6	2.35	50.6	0.048	53.8	0.707	171.7
2700	0.876	136.1	2.25	49.1	0.049	53.3	0.709	171.2
2800	0.876	134.6	2.16	47.7	0.050	52.4	0.711	170.6
2900	0.877	133.2	2.08	46.4	0.052	51.9	0.713	170.3
3000	0.879	131.9	2.00	45.2	0.053	51.0	0.715	169.8
3200	0.879	129.1	1.86	42.5	0.056	49.8	0.717	169.2
3400	0.880	126.3	1.74	39.9	0.059	48.4	0.716	168.5
3600	0.882	123.7	1.63	37.3	0.062	46.9	0.715	167.5
3800	0.882	121.1	1.54	34.6	0.064	45.2	0.711	166.2
4000	0.883	118.3	1.45	31.8	0.066	43.5	0.709	164.4
4200	0.884	115.8	1.36	29.0	0.068	41.8	0.710	162.4
4400	0.885	113.2	1.29	26.4	0.070	39.9	0.712	160.5
4600	0.886	110.6	1.21	23.7	0.072	38.2	0.716	158.9
4800	0.888	108.3	1.15	21.4	0.074	36.7	0.719	157.6
5000	0.889	106.0	1.09	19.0	0.076	34.6	0.721	156.6
5200	0.890	103.5	1.04	16.6	0.078	33.0	0.721	155.5
5400	0.892	101.3	0.99	14.0	0.080	31.0	0.720	153.9
5600	0.894	99.2	0.95	11.5	0.082	28.9	0.718	151.8
5800	0.895	96.9	0.90	8.9	0.083	27.1	0.720	149.4
6000	0.897	94.9	0.86	6.4	0.084	25.1	0.725	146.9

S Parameter

 $(V_{CE} = 3.3 \text{ V}, I_C = 250 \text{ mA}, Z_O = 50 \Omega)$

f (MHz)	S11		S21		S12		S22	
	MAG	ANG	MAG	ANG	MAG	ANG	MAG	ANG
100	0.843	-169.1	55.70	107.1	0.006	43.0	0.689	-146.4
200	0.862	-176.9	32.71	94.2	0.007	43.5	0.687	-163.1
300	0.863	179.0	22.13	89.6	0.009	47.8	0.688	-169.0
400	0.863	176.0	16.59	86.4	0.011	53.2	0.689	-172.2
500	0.864	173.6	13.23	84.0	0.012	57.1	0.690	-174.3
600	0.864	171.4	10.97	81.8	0.014	58.2	0.691	-175.9
700	0.864	169.3	9.37	79.8	0.016	59.8	0.692	-177.1
800	0.864	167.2	8.16	77.9	0.018	60.8	0.694	-178.1
900	0.864	165.2	7.22	76.2	0.019	61.4	0.695	-179.1
1000	0.865	163.4	6.46	74.6	0.021	62.2	0.697	-179.9
1100	0.867	161.6	5.85	73.0	0.023	62.7	0.699	179.5
1200	0.867	159.8	5.34	71.3	0.025	62.8	0.700	178.9
1300	0.866	158.0	4.90	69.8	0.027	62.3	0.702	178.4
1400	0.867	156.3	4.54	68.2	0.028	62.1	0.703	177.8
1500	0.867	154.5	4.22	66.7	0.030	62.2	0.704	177.3
1600	0.869	152.8	3.94	65.3	0.032	61.3	0.706	176.9
1700	0.870	151.2	3.69	63.9	0.033	61.0	0.707	176.4
1800	0.870	149.7	3.47	62.4	0.035	60.4	0.707	176.0
1900	0.871	148.0	3.28	60.9	0.037	59.4	0.707	175.5
2000	0.871	146.4	3.11	59.4	0.038	58.8	0.707	175.0
2100	0.871	144.8	2.95	57.9	0.040	58.3	0.708	174.4
2200	0.873	143.4	2.80	56.5	0.042	57.4	0.708	173.8
2300	0.875	141.8	2.67	55.1	0.043	57.0	0.709	173.2
2400	0.875	140.4	2.55	53.8	0.045	56.1	0.710	172.6
2500	0.876	138.9	2.44	52.3	0.047	55.4	0.711	172.0
2600	0.877	137.4	2.33	50.9	0.048	54.4	0.712	171.4
2700	0.878	135.9	2.23	49.4	0.050	54.0	0.715	170.8
2800	0.878	134.5	2.14	48.1	0.051	53.5	0.716	170.3
2900	0.879	133.1	2.06	46.8	0.052	52.7	0.719	169.9
3000	0.881	131.8	1.98	45.5	0.053	51.8	0.720	169.5
3200	0.882	129.0	1.84	42.9	0.057	50.6	0.722	168.9
3400	0.882	126.2	1.72	40.3	0.059	49.0	0.722	168.2
3600	0.883	123.6	1.62	37.7	0.062	47.5	0.720	167.2
3800	0.884	120.9	1.52	35.0	0.064	45.6	0.717	165.8
4000	0.884	118.2	1.43	32.2	0.067	43.9	0.715	164.0
4200	0.886	115.6	1.35	29.4	0.069	42.0	0.715	162.0
4400	0.887	113.1	1.28	26.9	0.071	40.3	0.718	160.1
4600	0.888	110.5	1.20	24.2	0.072	38.4	0.721	158.5
4800	0.889	108.2	1.14	21.9	0.074	37.2	0.724	157.3
5000	0.891	105.9	1.09	19.5	0.077	35.1	0.726	156.3
5200	0.891	103.4	1.03	17.2	0.079	33.3	0.726	155.1
5400	0.893	101.2	0.98	14.6	0.081	31.5	0.724	153.5
5600	0.895	99.1	0.94	12.1	0.082	29.3	0.722	151.4
5800	0.896	96.8	0.90	9.5	0.083	27.4	0.724	148.9
6000	0.898	94.8	0.85	7.1	0.084	25.4	0.729	146.5

S Parameter

 $(V_{CE} = 3.3 \text{ V}, I_C = 300 \text{ mA}, Z_O = 50 \Omega)$

f (MHz)	S11		S21		S12		S22	
	MAG	ANG	MAG	ANG	MAG	ANG	MAG	ANG
100	0.849	-170.3	52.00	107.5	0.005	44.8	0.686	-148.4
200	0.867	-177.8	31.15	94.4	0.007	48.3	0.689	-164.1
300	0.867	178.4	21.36	89.7	0.008	52.9	0.691	-169.8
400	0.867	175.5	16.08	86.5	0.011	54.2	0.693	-172.8
500	0.868	173.2	12.84	84.1	0.012	58.7	0.694	-174.7
600	0.867	171.0	10.66	81.9	0.013	60.1	0.695	-176.2
700	0.867	169.0	9.11	79.9	0.016	62.0	0.696	-177.4
800	0.867	166.9	7.93	78.1	0.017	63.4	0.697	-178.4
900	0.868	165.0	7.02	76.4	0.019	63.4	0.699	-179.4
1000	0.868	163.1	6.29	74.7	0.021	63.8	0.701	179.9
1100	0.870	161.4	5.69	73.1	0.023	63.9	0.702	179.2
1200	0.870	159.6	5.20	71.5	0.025	63.7	0.704	178.7
1300	0.869	157.8	4.77	69.9	0.026	63.5	0.706	178.1
1400	0.870	156.1	4.42	68.4	0.028	63.5	0.706	177.5
1500	0.870	154.3	4.11	66.9	0.030	62.5	0.707	177.1
1600	0.871	152.7	3.84	65.5	0.032	62.3	0.709	176.8
1700	0.873	151.1	3.60	64.0	0.034	61.4	0.711	176.2
1800	0.873	149.5	3.38	62.6	0.035	61.1	0.710	175.7
1900	0.874	147.9	3.20	61.1	0.037	60.4	0.710	175.3
2000	0.874	146.3	3.03	59.6	0.039	59.4	0.710	174.8
2100	0.874	144.7	2.87	58.1	0.040	58.8	0.711	174.2
2200	0.876	143.3	2.73	56.7	0.042	58.2	0.712	173.6
2300	0.877	141.7	2.60	55.3	0.043	57.7	0.712	173.0
2400	0.878	140.3	2.48	53.9	0.045	56.7	0.713	172.4
2500	0.879	138.8	2.37	52.5	0.047	55.9	0.715	171.8
2600	0.879	137.3	2.27	51.1	0.048	55.2	0.716	171.2
2700	0.880	135.8	2.18	49.6	0.050	54.3	0.718	170.6
2800	0.880	134.4	2.09	48.3	0.051	53.7	0.720	170.1
2900	0.882	133.0	2.01	47.0	0.052	53.1	0.722	169.8
3000	0.883	131.7	1.94	45.7	0.054	52.3	0.723	169.3
3200	0.884	128.9	1.80	43.1	0.057	51.1	0.725	168.7
3400	0.884	126.1	1.68	40.5	0.060	49.4	0.725	168.0
3600	0.886	123.5	1.58	37.9	0.062	47.7	0.723	167.0
3800	0.886	120.8	1.49	35.3	0.064	46.1	0.720	165.7
4000	0.887	118.1	1.40	32.4	0.067	44.3	0.717	163.8
4200	0.888	115.5	1.32	29.7	0.069	42.5	0.718	161.9
4400	0.889	113.0	1.25	27.1	0.071	40.6	0.721	159.9
4600	0.890	110.4	1.18	24.5	0.073	38.9	0.724	158.3
4800	0.891	108.1	1.11	22.2	0.075	37.5	0.727	157.1
5000	0.892	105.8	1.06	19.8	0.077	35.2	0.729	156.0
5200	0.893	103.3	1.01	17.5	0.079	33.6	0.729	154.9
5400	0.895	101.1	0.96	14.9	0.081	31.5	0.727	153.3
5600	0.897	99.0	0.92	12.4	0.083	29.4	0.725	151.2
5800	0.897	96.7	0.87	9.8	0.084	27.6	0.727	148.7
6000	0.900	94.7	0.83	7.4	0.085	25.5	0.732	146.3

S Parameter

 $(V_{CE} = 3.6 \text{ V}, I_C = 50 \text{ mA}, Z_O = 50 \Omega)$

f (MHz)	S11		S21		S12		S22	
	MAG	ANG	MAG	ANG	MAG	ANG	MAG	ANG
100	0.753	-131.9	52.27	117.8	0.016	24.0	0.640	-110.9
200	0.816	-159.8	30.38	100.8	0.017	21.5	0.589	-141.5
300	0.827	-169.5	20.65	93.6	0.018	21.7	0.578	-153.5
400	0.832	-175.2	15.52	88.9	0.020	24.3	0.577	-159.8
500	0.834	-179.3	12.38	85.3	0.020	25.9	0.576	-163.6
600	0.836	177.4	10.27	82.4	0.021	27.8	0.577	-166.3
700	0.837	174.6	8.77	79.7	0.021	30.5	0.578	-168.4
800	0.838	171.9	7.62	77.2	0.022	32.0	0.581	-170.1
900	0.839	169.5	6.72	75.0	0.023	33.7	0.583	-171.4
1000	0.841	167.3	6.01	72.9	0.024	35.9	0.587	-172.5
1100	0.843	165.2	5.44	70.9	0.025	36.6	0.589	-173.3
1200	0.845	163.2	4.96	68.9	0.027	38.5	0.593	-174.1
1300	0.845	161.2	4.54	67.0	0.028	39.7	0.594	-174.7
1400	0.846	159.4	4.20	65.2	0.029	41.2	0.597	-175.4
1500	0.847	157.4	3.89	63.3	0.030	42.1	0.600	-175.9
1600	0.849	155.6	3.63	61.6	0.031	42.6	0.603	-176.4
1700	0.851	153.9	3.39	59.9	0.032	42.9	0.605	-176.8
1800	0.852	152.3	3.19	58.2	0.034	43.3	0.606	-177.2
1900	0.854	150.6	3.00	56.5	0.035	43.2	0.608	-177.6
2000	0.855	148.8	2.84	54.7	0.037	43.6	0.610	-178.2
2100	0.855	147.2	2.69	53.0	0.037	44.0	0.611	-178.8
2200	0.858	145.7	2.55	51.4	0.039	43.8	0.613	-179.4
2300	0.860	144.0	2.43	49.8	0.040	43.7	0.615	-179.9
2400	0.861	142.6	2.31	48.2	0.041	43.7	0.617	179.5
2500	0.863	141.0	2.21	46.5	0.043	43.6	0.620	178.9
2600	0.863	139.5	2.11	44.9	0.044	43.6	0.623	178.3
2700	0.865	137.9	2.02	43.3	0.045	43.4	0.626	177.8
2800	0.866	136.4	1.93	41.7	0.046	43.3	0.630	177.4
2900	0.867	135.0	1.85	40.3	0.047	43.4	0.633	177.0
3000	0.870	133.6	1.78	38.8	0.049	42.6	0.636	176.6
3200	0.871	130.8	1.65	35.8	0.051	42.5	0.641	176.1
3400	0.873	127.9	1.54	32.9	0.054	41.7	0.644	175.5
3600	0.876	125.2	1.44	30.0	0.056	40.7	0.645	174.7
3800	0.877	122.5	1.35	27.0	0.058	39.8	0.644	173.5
4000	0.878	119.7	1.26	24.0	0.060	38.9	0.644	171.8
4200	0.881	117.1	1.19	20.9	0.062	37.4	0.646	169.7
4400	0.882	114.5	1.12	18.1	0.064	35.8	0.651	167.8
4600	0.883	111.9	1.05	15.2	0.066	34.7	0.658	166.1
4800	0.886	109.5	0.99	12.6	0.067	33.7	0.664	164.9
5000	0.888	107.1	0.94	10.1	0.070	32.0	0.670	163.9
5200	0.889	104.6	0.89	7.5	0.072	30.7	0.672	162.7
5400	0.892	102.4	0.84	4.8	0.074	28.8	0.673	161.2
5600	0.894	100.2	0.80	2.1	0.076	27.1	0.673	159.2
5800	0.895	97.9	0.76	-0.6	0.077	25.7	0.677	156.6
6000	0.898	95.8	0.72	-3.2	0.078	23.7	0.683	154.0

S Parameter

 $(V_{CE} = 3.6 \text{ V}, I_C = 100 \text{ mA}, Z_O = 50 \Omega)$

f (MHz)	S11		S21		S12		S22	
	MAG	ANG	MAG	ANG	MAG	ANG	MAG	ANG
100	0.753	-131.9	52.27	117.8	0.016	24.0	0.640	-110.9
200	0.816	-159.8	30.38	100.8	0.017	21.5	0.589	-141.5
300	0.827	-169.5	20.65	93.6	0.018	21.7	0.578	-153.5
400	0.832	-175.2	15.52	88.9	0.020	24.3	0.577	-159.8
500	0.834	-179.3	12.38	85.3	0.020	25.9	0.576	-163.6
600	0.836	177.4	10.27	82.4	0.021	27.8	0.577	-166.3
700	0.837	174.6	8.77	79.7	0.021	30.5	0.578	-168.4
800	0.838	171.9	7.62	77.2	0.022	32.0	0.581	-170.1
900	0.839	169.5	6.72	75.0	0.023	33.7	0.583	-171.4
1000	0.841	167.3	6.01	72.9	0.024	35.9	0.587	-172.5
1100	0.843	165.2	5.44	70.9	0.025	36.6	0.589	-173.3
1200	0.845	163.2	4.96	68.9	0.027	38.5	0.593	-174.1
1300	0.845	161.2	4.54	67.0	0.028	39.7	0.594	-174.7
1400	0.846	159.4	4.20	65.2	0.029	41.2	0.597	-175.4
1500	0.847	157.4	3.89	63.3	0.030	42.1	0.600	-175.9
1600	0.849	155.6	3.63	61.6	0.031	42.6	0.603	-176.4
1700	0.851	153.9	3.39	59.9	0.032	42.9	0.605	-176.8
1800	0.852	152.3	3.19	58.2	0.034	43.3	0.606	-177.2
1900	0.854	150.6	3.00	56.5	0.035	43.2	0.608	-177.6
2000	0.855	148.8	2.84	54.7	0.037	43.6	0.610	-178.2
2100	0.855	147.2	2.69	53.0	0.037	44.0	0.611	-178.8
2200	0.858	145.7	2.55	51.4	0.039	43.8	0.613	-179.4
2300	0.860	144.0	2.43	49.8	0.040	43.7	0.615	-179.9
2400	0.861	142.6	2.31	48.2	0.041	43.7	0.617	179.5
2500	0.863	141.0	2.21	46.5	0.043	43.6	0.620	178.9
2600	0.863	139.5	2.11	44.9	0.044	43.6	0.623	178.3
2700	0.865	137.9	2.02	43.3	0.045	43.4	0.626	177.8
2800	0.866	136.4	1.93	41.7	0.046	43.3	0.630	177.4
2900	0.867	135.0	1.85	40.3	0.047	43.4	0.633	177.0
3000	0.870	133.6	1.78	38.8	0.049	42.6	0.636	176.6
3200	0.871	130.8	1.65	35.8	0.051	42.5	0.641	176.1
3400	0.873	127.9	1.54	32.9	0.054	41.7	0.644	175.5
3600	0.876	125.2	1.44	30.0	0.056	40.7	0.645	174.7
3800	0.877	122.5	1.35	27.0	0.058	39.8	0.644	173.5
4000	0.878	119.7	1.26	24.0	0.060	38.9	0.644	171.8
4200	0.881	117.1	1.19	20.9	0.062	37.4	0.646	169.7
4400	0.882	114.5	1.12	18.1	0.064	35.8	0.651	167.8
4600	0.883	111.9	1.05	15.2	0.066	34.7	0.658	166.1
4800	0.886	109.5	0.99	12.6	0.067	33.7	0.664	164.9
5000	0.888	107.1	0.94	10.1	0.070	32.0	0.670	163.9
5200	0.889	104.6	0.89	7.5	0.072	30.7	0.672	162.7
5400	0.892	102.4	0.84	4.8	0.074	28.8	0.673	161.2
5600	0.894	100.2	0.80	2.1	0.076	27.1	0.673	159.2
5800	0.895	97.9	0.76	-0.6	0.077	25.7	0.677	156.6
6000	0.898	95.8	0.72	-3.2	0.078	23.7	0.683	154.0

S Parameter

 $(V_{CE} = 3.6 \text{ V}, I_C = 150 \text{ mA}, Z_O = 50 \Omega)$

f (MHz)	S11		S21		S12		S22	
	MAG	ANG	MAG	ANG	MAG	ANG	MAG	ANG
100	0.813	-164.9	60.85	109.6	0.007	18.7	0.671	-139.1
200	0.847	-173.7	33.74	95.9	0.009	35.8	0.663	-159.2
300	0.853	-178.8	22.67	90.5	0.010	36.5	0.664	-166.4
400	0.854	177.7	16.97	87.0	0.012	43.7	0.666	-170.0
500	0.855	175.0	13.52	84.3	0.013	47.8	0.666	-172.4
600	0.855	172.5	11.21	81.9	0.015	52.1	0.667	-174.2
700	0.856	170.3	9.57	79.8	0.016	53.0	0.669	-175.6
800	0.856	168.1	8.32	77.8	0.018	54.6	0.670	-176.7
900	0.856	166.0	7.36	76.0	0.019	55.4	0.672	-177.8
1000	0.857	164.1	6.59	74.2	0.021	57.2	0.674	-178.6
1100	0.859	162.3	5.96	72.6	0.023	57.1	0.676	-179.3
1200	0.859	160.5	5.44	70.9	0.025	57.5	0.678	-179.9
1300	0.859	158.6	4.99	69.2	0.026	57.2	0.679	179.6
1400	0.860	156.9	4.62	67.7	0.028	58.6	0.681	178.9
1500	0.860	155.0	4.29	66.1	0.030	58.0	0.682	178.5
1600	0.862	153.4	4.00	64.6	0.032	57.8	0.684	178.0
1700	0.863	151.7	3.75	63.1	0.033	57.3	0.685	177.5
1800	0.864	150.2	3.53	61.6	0.035	57.1	0.685	177.1
1900	0.865	148.5	3.33	60.1	0.036	56.7	0.686	176.6
2000	0.865	146.9	3.15	58.5	0.038	55.8	0.686	176.1
2100	0.865	145.3	2.99	57.0	0.039	55.6	0.687	175.5
2200	0.868	143.8	2.84	55.6	0.041	54.9	0.688	174.9
2300	0.869	142.3	2.71	54.1	0.043	54.5	0.688	174.3
2400	0.870	140.8	2.58	52.7	0.044	53.9	0.689	173.7
2500	0.871	139.3	2.47	51.2	0.046	53.2	0.691	173.1
2600	0.871	137.8	2.36	49.8	0.047	52.6	0.693	172.5
2700	0.872	136.3	2.26	48.3	0.049	51.9	0.695	171.9
2800	0.873	134.9	2.17	46.9	0.050	51.3	0.697	171.5
2900	0.874	133.4	2.08	45.6	0.051	50.5	0.699	171.1
3000	0.876	132.1	2.01	44.3	0.053	49.9	0.700	170.7
3200	0.877	129.3	1.87	41.6	0.056	48.9	0.703	170.0
3400	0.878	126.5	1.74	38.9	0.058	47.5	0.703	169.4
3600	0.879	123.9	1.63	36.3	0.061	45.9	0.702	168.4
3800	0.880	121.2	1.54	33.5	0.063	44.5	0.699	167.1
4000	0.881	118.5	1.45	30.7	0.065	42.8	0.697	165.3
4200	0.882	115.9	1.36	27.8	0.067	41.0	0.697	163.3
4400	0.883	113.4	1.29	25.2	0.069	39.3	0.700	161.4
4600	0.884	110.8	1.21	22.5	0.071	37.7	0.704	159.8
4800	0.886	108.4	1.15	20.1	0.073	36.2	0.707	158.6
5000	0.888	106.2	1.09	17.7	0.075	34.2	0.710	157.6
5200	0.889	103.7	1.04	15.3	0.077	32.7	0.710	156.4
5400	0.891	101.5	0.99	12.6	0.079	30.7	0.709	154.9
5600	0.893	99.3	0.94	10.1	0.081	28.7	0.707	152.7
5800	0.894	97.1	0.90	7.4	0.082	26.9	0.710	150.3
6000	0.896	95.0	0.85	5.0	0.083	24.7	0.715	147.8

S Parameter

 $(V_{CE} = 3.6 \text{ V}, I_C = 200 \text{ mA}, Z_O = 50 \Omega)$

f (MHz)	S11		S21		S12		S22	
	MAG	ANG	MAG	ANG	MAG	ANG	MAG	ANG
100	0.826	-167.4	59.94	108.5	0.007	38.7	0.680	-143.1
200	0.854	-175.5	33.77	95.0	0.008	37.1	0.676	-161.4
300	0.857	179.9	22.69	90.0	0.009	45.9	0.676	-167.8
400	0.859	176.8	16.99	86.6	0.012	47.7	0.678	-171.2
500	0.859	174.2	13.53	84.1	0.013	52.1	0.679	-173.5
600	0.859	171.8	11.22	81.8	0.014	54.6	0.680	-175.1
700	0.860	169.7	9.58	79.8	0.016	56.6	0.681	-176.4
800	0.860	167.6	8.34	77.9	0.018	58.6	0.683	-177.5
900	0.860	165.6	7.37	76.1	0.020	59.6	0.685	-178.5
1000	0.861	163.7	6.60	74.4	0.021	60.3	0.687	-179.3
1100	0.862	161.9	5.97	72.8	0.023	59.8	0.688	-180.0
1200	0.863	160.0	5.45	71.2	0.025	60.6	0.690	179.4
1300	0.862	158.2	5.00	69.6	0.026	60.7	0.691	178.9
1400	0.863	156.5	4.63	68.0	0.028	60.9	0.693	178.3
1500	0.863	154.7	4.30	66.4	0.030	60.5	0.694	177.8
1600	0.865	153.1	4.02	65.0	0.032	60.1	0.695	177.4
1700	0.866	151.4	3.77	63.6	0.033	59.4	0.697	176.9
1800	0.867	149.9	3.54	62.1	0.035	59.0	0.697	176.4
1900	0.867	148.3	3.34	60.6	0.037	58.2	0.697	176.0
2000	0.868	146.6	3.17	59.1	0.038	57.7	0.697	175.5
2100	0.868	145.0	3.00	57.6	0.040	57.3	0.698	174.9
2200	0.870	143.6	2.86	56.1	0.042	56.6	0.698	174.2
2300	0.871	142.0	2.72	54.7	0.043	55.9	0.699	173.7
2400	0.872	140.6	2.59	53.3	0.045	55.1	0.700	173.1
2500	0.873	139.0	2.48	51.9	0.046	54.4	0.702	172.5
2600	0.873	137.6	2.37	50.4	0.047	53.8	0.703	171.8
2700	0.875	136.1	2.27	49.0	0.049	53.1	0.705	171.3
2800	0.875	134.7	2.18	47.6	0.050	52.4	0.707	170.8
2900	0.876	133.3	2.10	46.3	0.052	52.0	0.709	170.4
3000	0.878	131.9	2.02	45.0	0.053	51.0	0.711	170.0
3200	0.879	129.1	1.88	42.4	0.056	49.7	0.713	169.3
3400	0.879	126.3	1.75	39.7	0.059	48.5	0.713	168.7
3600	0.881	123.7	1.65	37.1	0.062	46.9	0.711	167.7
3800	0.882	121.0	1.55	34.4	0.064	45.0	0.708	166.3
4000	0.882	118.3	1.46	31.6	0.066	43.5	0.706	164.6
4200	0.884	115.8	1.38	28.8	0.068	41.7	0.706	162.6
4400	0.885	113.2	1.30	26.2	0.070	40.0	0.709	160.7
4600	0.886	110.6	1.22	23.5	0.072	38.3	0.712	159.0
4800	0.887	108.3	1.16	21.2	0.074	36.7	0.715	157.8
5000	0.889	106.0	1.10	18.8	0.076	34.6	0.718	156.8
5200	0.890	103.5	1.05	16.3	0.078	33.0	0.718	155.7
5400	0.892	101.3	1.00	13.8	0.080	31.0	0.717	154.1
5600	0.893	99.2	0.95	11.2	0.081	29.1	0.715	152.0
5800	0.894	97.0	0.91	8.6	0.083	27.3	0.717	149.5
6000	0.897	94.9	0.86	6.2	0.084	25.1	0.722	147.1

S Parameter

 $(V_{CE} = 3.6 \text{ V}, I_C = 250 \text{ mA}, Z_O = 50 \Omega)$

f (MHz)	S11		S21		S12		S22	
	MAG	ANG	MAG	ANG	MAG	ANG	MAG	ANG
100	0.837	-169.0	57.69	108.0	0.005	40.2	0.683	-145.3
200	0.859	-176.8	33.26	94.6	0.007	43.2	0.682	-162.6
300	0.861	179.1	22.42	89.8	0.008	45.4	0.683	-168.7
400	0.862	176.1	16.79	86.5	0.011	54.1	0.685	-171.9
500	0.863	173.7	13.38	84.1	0.012	55.3	0.686	-174.0
600	0.862	171.4	11.10	81.9	0.014	58.5	0.687	-175.6
700	0.863	169.3	9.48	79.8	0.016	59.9	0.688	-176.9
800	0.863	167.2	8.25	78.0	0.018	60.5	0.690	-177.9
900	0.863	165.2	7.30	76.3	0.019	62.1	0.691	-178.9
1000	0.863	163.4	6.54	74.6	0.021	61.4	0.693	-179.7
1100	0.865	161.6	5.91	73.0	0.023	62.2	0.694	179.7
1200	0.866	159.8	5.40	71.3	0.025	61.9	0.696	179.1
1300	0.865	158.0	4.96	69.8	0.026	61.8	0.698	178.5
1400	0.866	156.3	4.59	68.2	0.028	62.2	0.699	177.9
1500	0.866	154.5	4.26	66.7	0.030	61.3	0.700	177.5
1600	0.867	152.8	3.98	65.3	0.032	61.2	0.701	177.1
1700	0.868	151.2	3.73	63.8	0.034	60.5	0.703	176.6
1800	0.869	149.7	3.51	62.4	0.035	60.0	0.703	176.1
1900	0.870	148.1	3.32	60.8	0.037	59.1	0.703	175.7
2000	0.870	146.5	3.14	59.4	0.038	58.6	0.703	175.1
2100	0.870	144.8	2.98	57.9	0.040	58.2	0.703	174.5
2200	0.872	143.4	2.83	56.4	0.042	57.4	0.704	173.9
2300	0.874	141.8	2.70	55.0	0.043	57.0	0.704	173.3
2400	0.874	140.4	2.57	53.7	0.045	55.9	0.706	172.7
2500	0.875	138.9	2.46	52.2	0.046	54.9	0.707	172.1
2600	0.876	137.5	2.35	50.8	0.048	54.6	0.709	171.5
2700	0.877	135.9	2.26	49.3	0.049	53.8	0.711	170.9
2800	0.877	134.5	2.17	48.0	0.051	53.0	0.713	170.5
2900	0.878	133.1	2.08	46.7	0.052	52.5	0.715	170.1
3000	0.879	131.8	2.01	45.4	0.053	51.5	0.716	169.7
3200	0.881	129.0	1.86	42.8	0.057	50.3	0.718	169.0
3400	0.881	126.2	1.74	40.2	0.059	48.9	0.718	168.3
3600	0.883	123.6	1.64	37.5	0.062	47.4	0.716	167.3
3800	0.883	120.9	1.54	34.9	0.064	46.0	0.713	166.0
4000	0.883	118.2	1.45	32.0	0.067	43.9	0.711	164.2
4200	0.885	115.6	1.37	29.2	0.069	42.2	0.711	162.2
4400	0.886	113.1	1.29	26.7	0.070	40.3	0.714	160.3
4600	0.887	110.5	1.22	24.0	0.072	38.4	0.717	158.7
4800	0.889	108.2	1.15	21.7	0.074	37.1	0.720	157.4
5000	0.890	105.9	1.10	19.3	0.076	35.0	0.723	156.4
5200	0.891	103.4	1.04	16.9	0.078	33.4	0.722	155.2
5400	0.893	101.2	0.99	14.3	0.080	31.1	0.721	153.7
5600	0.894	99.1	0.95	11.8	0.082	29.4	0.719	151.6
5800	0.895	96.8	0.90	9.2	0.083	27.5	0.721	149.1
6000	0.898	94.8	0.86	6.8	0.084	25.4	0.726	146.7

S Parameter

 $(V_{CE} = 3.6 \text{ V}, I_C = 300 \text{ mA}, Z_O = 50 \Omega)$

f (MHz)	S11		S21		S12		S22	
	MAG	ANG	MAG	ANG	MAG	ANG	MAG	ANG
100	0.844	-170.2	54.08	108.2	0.006	54.3	0.682	-146.9
200	0.864	-177.6	31.88	94.6	0.006	44.2	0.684	-163.5
300	0.866	178.6	21.72	89.8	0.008	49.7	0.687	-169.4
400	0.866	175.7	16.32	86.6	0.011	54.5	0.688	-172.4
500	0.866	173.3	13.01	84.1	0.012	58.9	0.689	-174.4
600	0.866	171.1	10.81	82.0	0.014	60.8	0.691	-176.0
700	0.866	169.0	9.23	79.9	0.016	61.4	0.691	-177.2
800	0.866	167.0	8.04	78.1	0.018	62.4	0.693	-178.2
900	0.866	165.0	7.11	76.4	0.019	63.2	0.695	-179.2
1000	0.867	163.2	6.37	74.7	0.021	63.1	0.696	-180.0
1100	0.869	161.4	5.77	73.1	0.023	63.3	0.697	179.4
1200	0.869	159.6	5.26	71.5	0.025	63.5	0.699	178.9
1300	0.868	157.8	4.84	69.9	0.026	63.5	0.701	178.3
1400	0.869	156.1	4.48	68.3	0.028	63.7	0.701	177.7
1500	0.869	154.3	4.16	66.8	0.030	62.5	0.702	177.3
1600	0.870	152.7	3.89	65.4	0.032	61.9	0.704	177.0
1700	0.871	151.1	3.65	64.0	0.034	61.2	0.706	176.4
1800	0.872	149.5	3.43	62.5	0.035	61.0	0.706	175.9
1900	0.873	147.9	3.24	61.0	0.037	60.0	0.705	175.5
2000	0.873	146.3	3.07	59.5	0.039	59.3	0.706	174.9
2100	0.873	144.7	2.91	58.0	0.040	58.7	0.706	174.4
2200	0.875	143.3	2.77	56.6	0.042	58.2	0.707	173.7
2300	0.876	141.7	2.64	55.2	0.043	57.6	0.708	173.1
2400	0.877	140.3	2.51	53.8	0.045	56.8	0.708	172.6
2500	0.878	138.8	2.41	52.3	0.047	55.9	0.710	171.9
2600	0.878	137.3	2.30	50.9	0.048	55.0	0.712	171.3
2700	0.879	135.8	2.21	49.5	0.049	54.5	0.714	170.8
2800	0.880	134.4	2.12	48.1	0.051	53.5	0.715	170.3
2900	0.880	133.0	2.03	46.9	0.052	53.1	0.718	169.9
3000	0.882	131.7	1.96	45.6	0.054	52.2	0.719	169.5
3200	0.883	128.9	1.82	43.0	0.057	51.0	0.721	168.8
3400	0.884	126.1	1.70	40.4	0.059	49.4	0.721	168.2
3600	0.885	123.5	1.60	37.7	0.062	47.7	0.719	167.2
3800	0.885	120.8	1.50	35.1	0.065	45.8	0.716	165.8
4000	0.886	118.1	1.42	32.2	0.067	44.1	0.714	164.0
4200	0.887	115.5	1.34	29.5	0.069	42.4	0.714	162.0
4400	0.888	113.0	1.26	26.9	0.071	40.6	0.717	160.1
4600	0.889	110.4	1.19	24.2	0.072	38.9	0.720	158.5
4800	0.890	108.1	1.12	21.9	0.075	37.4	0.723	157.3
5000	0.891	105.8	1.07	19.6	0.077	35.2	0.725	156.2
5200	0.892	103.3	1.02	17.2	0.079	33.6	0.725	155.0
5400	0.894	101.1	0.97	14.7	0.081	31.4	0.723	153.5
5600	0.896	99.0	0.93	12.1	0.083	29.5	0.721	151.4
5800	0.897	96.7	0.88	9.5	0.084	27.6	0.724	148.9
6000	0.899	94.7	0.84	7.1	0.084	25.6	0.729	146.4

Package Dimensions

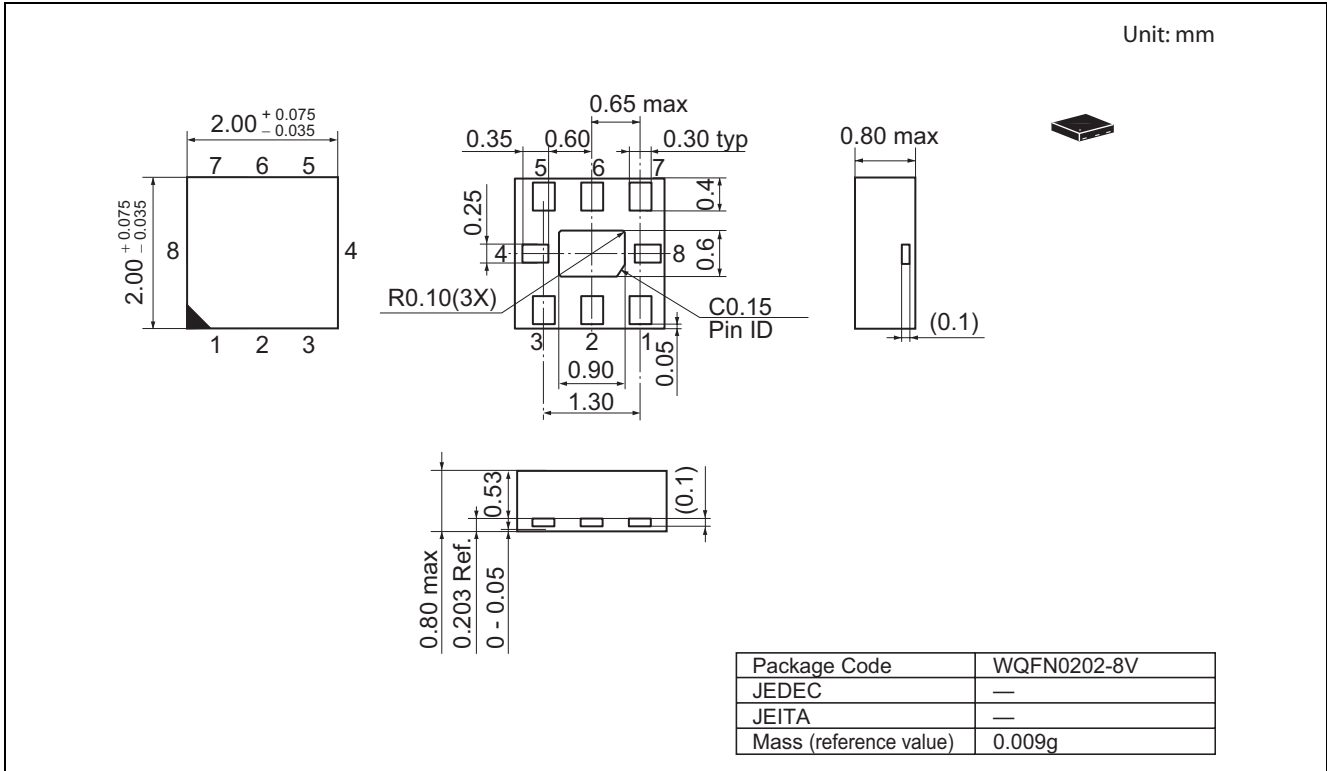

Ordering Information

Part Name	Quantity	Shipping Container
HSG2002TR	3000	φ178 taping

Note: Therefore especially small contact area of terminal, miss contact may occur if inadequate soldering condition is applied.

Contact Renesas sales office for any question regarding recommended soldering condition of Renesas.

Renesas Technology Corp. Sales Strategic Planning Div. Nippon Bldg., 2-6-2, Ohte-machi, Chiyoda-ku, Tokyo 100-0004, Japan

Keep safety first in your circuit designs!

1. Renesas Technology Corp. puts the maximum effort into making semiconductor products better and more reliable, but there is always the possibility that trouble may occur with them. Trouble with semiconductors may lead to personal injury, fire or property damage.
Remember to give due consideration to safety when making your circuit designs, with appropriate measures such as (i) placement of substitutive, auxiliary circuits, (ii) use of nonflammable material or (iii) prevention against any malfunction or mishap.

Notes regarding these materials

1. These materials are intended as a reference to assist our customers in the selection of the Renesas Technology Corp. product best suited to the customer's application; they do not convey any license under any intellectual property rights, or any other rights, belonging to Renesas Technology Corp. or a third party.
 2. Renesas Technology Corp. assumes no responsibility for any damage, or infringement of any third-party's rights, originating in the use of any product data, diagrams, charts, programs, algorithms, or circuit application examples contained in these materials.
 3. All information contained in these materials, including product data, diagrams, charts, programs and algorithms represents information on products at the time of publication of these materials, and are subject to change by Renesas Technology Corp. without notice due to product improvements or other reasons. It is therefore recommended that customers contact Renesas Technology Corp. or an authorized Renesas Technology Corp. product distributor for the latest product information before purchasing a product listed herein.
The information described here may contain technical inaccuracies or typographical errors.
Renesas Technology Corp. assumes no responsibility for any damage, liability, or other loss rising from these inaccuracies or errors.
Please also pay attention to information published by Renesas Technology Corp. by various means, including the Renesas Technology Corp. Semiconductor home page (<http://www.renesas.com>).
 4. When using any or all of the information contained in these materials, including product data, diagrams, charts, programs, and algorithms, please be sure to evaluate all information as a total system before making a final decision on the applicability of the information and products. Renesas Technology Corp. assumes no responsibility for any damage, liability or other loss resulting from the information contained herein.
 5. Renesas Technology Corp. semiconductors are not designed or manufactured for use in a device or system that is used under circumstances in which human life is potentially at stake. Please contact Renesas Technology Corp. or an authorized Renesas Technology Corp. product distributor when considering the use of a product contained herein for any specific purposes, such as apparatus or systems for transportation, vehicular, medical, aerospace, nuclear, or undersea repeater use.
 6. The prior written approval of Renesas Technology Corp. is necessary to reprint or reproduce in whole or in part these materials.
 7. If these products or technologies are subject to the Japanese export control restrictions, they must be exported under a license from the Japanese government and cannot be imported into a country other than the approved destination.
Any diversion or reexport contrary to the export control laws and regulations of Japan and/or the country of destination is prohibited.
 8. Please contact Renesas Technology Corp. for further details on these materials or the products contained therein.
-



RENESAS SALES OFFICES

<http://www.renesas.com>

Refer to "<http://www.renesas.com/en/network>" for the latest and detailed information.

Renesas Technology America, Inc.
450 Holger Way, San Jose, CA 95134-1368, U.S.A
Tel: <1> (408) 382-7500, Fax: <1> (408) 382-7501

Renesas Technology Europe Limited
Dukes Meadow, Millboard Road, Bourne End, Buckinghamshire, SL8 5FH, U.K.
Tel: <44> (1628) 585-100, Fax: <44> (1628) 585-900

Renesas Technology Hong Kong Ltd.
7th Floor, North Tower, World Finance Centre, Harbour City, 1 Canton Road, Tsimshatsui, Kowloon, Hong Kong
Tel: <852> 2265-6688, Fax: <852> 2730-6071

Renesas Technology Taiwan Co., Ltd.
10th Floor, No.99, Fushing North Road, Taipei, Taiwan
Tel: <886> (2) 2715-2888, Fax: <886> (2) 2713-2999

Renesas Technology (Shanghai) Co., Ltd.
Unit2607 Ruijing Building, No.205 Maoming Road (S), Shanghai 200020, China
Tel: <86> (21) 6472-1001, Fax: <86> (21) 6415-2952

Renesas Technology Singapore Pte. Ltd.
1 Harbour Front Avenue, #06-10, Keppel Bay Tower, Singapore 098632
Tel: <65> 6213-0200, Fax: <65> 6278-8001