

- **Medium-Resolution, Solid-State Image Sensor for Low-Cost Color TV Applications**
- **324(H) x 243(V) Active Elements in Image Sensing Area**
- **10- μ m Square Pixels**
- **Small Size**
- **Low Cost**
- **Fast Clear Capability**
- **Electronic Shutter Function From 1/60–1/50000 s**
- **Low Dark Current**
- **Electron-Hole Recombination Antiblooming**
- **Dynamic Range . . . 66 dB Typical**
- **High Sensitivity**
- **High Blue Response**
- **8-Pin Dual-In-Line Plastic Package**
- **4-mm Image-Area Diagonal**
- **Solid-State Reliability With No Image Burn-In, Residual Imaging, Image Distortion, Image Lag, or Microphonics**

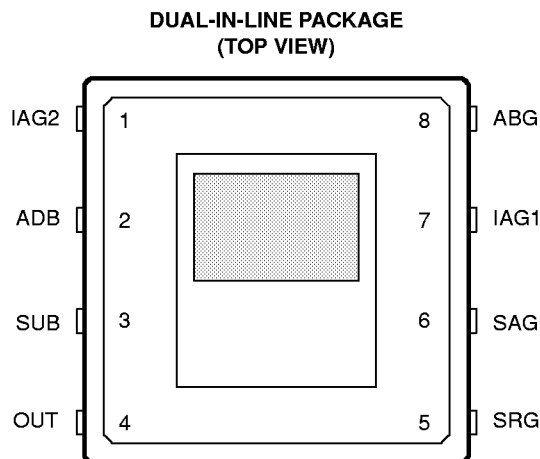

description

The TC254P is a frame-transfer charge-coupled device (CCD) designed for use in color NTSC TV and special-purpose applications requiring low cost and small size.

The image-sensing area of the TC254P is configured in 243 lines with 336 elements in each line. Twelve elements are provided in each line for dark reference. The blooming-protection feature of the sensor is based on recombining excess charge with charge of opposite polarity in the substrate. This antiblooming is activated by supplying clocking pulses to the antiblooming gate, which is an integral part of each image-sensing element.

The sensor can be operated in a non-interlace mode as a 324(H) by 243(V) square color pixel mode by alternately averaging two red pixels for red pixels and two blue pixels for blue pixels. Because the human eye is most sensitive to the green light wavelength, the 324×243 resolution is preserved due to the orientation of the green pixels in the Bayer mosaic color filter pattern.

The device can also be operated in a 162(H) by 121(V) square color pixel mode by utilizing a separate red, two averaged greens, and a blue pixel for each color pixel. In this mode, true interlaced video is possible, effectively increasing the vertical resolution, by performing a one pixel shift during the off-chip video processing.

One important aspect of this image sensor is its high-speed image-transfer capability. This capability allows for an electronic shutter function comparable to interline-transfer and frame-interline-transfer sensors without the loss of sensitivity and resolution inherent in those technologies.



This MOS device contains limited built-in gate protection. During storage or handling, the device leads should be shorted together or the device should be placed in conductive foam. In a circuit, unused inputs should always be connected to SUB. Under no circumstances should pin voltages exceed absolute maximum ratings. Avoid shorting OUT_n to ADB during operation to prevent damage to the amplifier. The device can also be damaged if the output terminals are reverse-biased and an excessive current is allowed to flow. Specific guidelines for handling devices of this type are contained in the publication *Guidelines for Handling Electrostatic-Discharge-Sensitive (ESDS) Devices and Assemblies* available from Texas Instruments.

TC254P

336- × 244-PIXEL CCD IMAGE SENSOR

SOCS060B – JUNE 1997 – REVISED JULY 1998

description (continued)

Charge is converted to signal voltage with a 12- μ V per electron conversion factor by a high-performance charge-detection structure with built-in automatic reset and a voltage reference generator. The signal is buffered by a low-noise two-stage source-follower amplifier to provide high output-drive capability.

The TC254P is built using TI-proprietary virtual-phase technology, which provides devices with high blue response, low dark current, high photoresponse uniformity, and single-phase clocking. The TC254P is characterized for operation from -10°C to 45°C .

functional block diagram

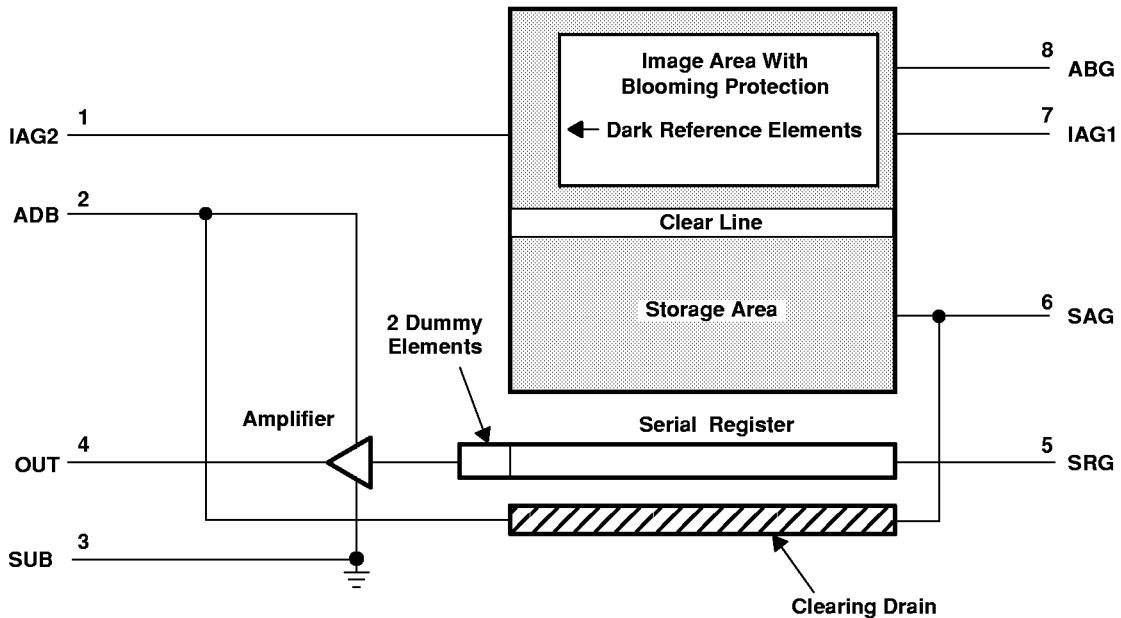

sensor topology diagram

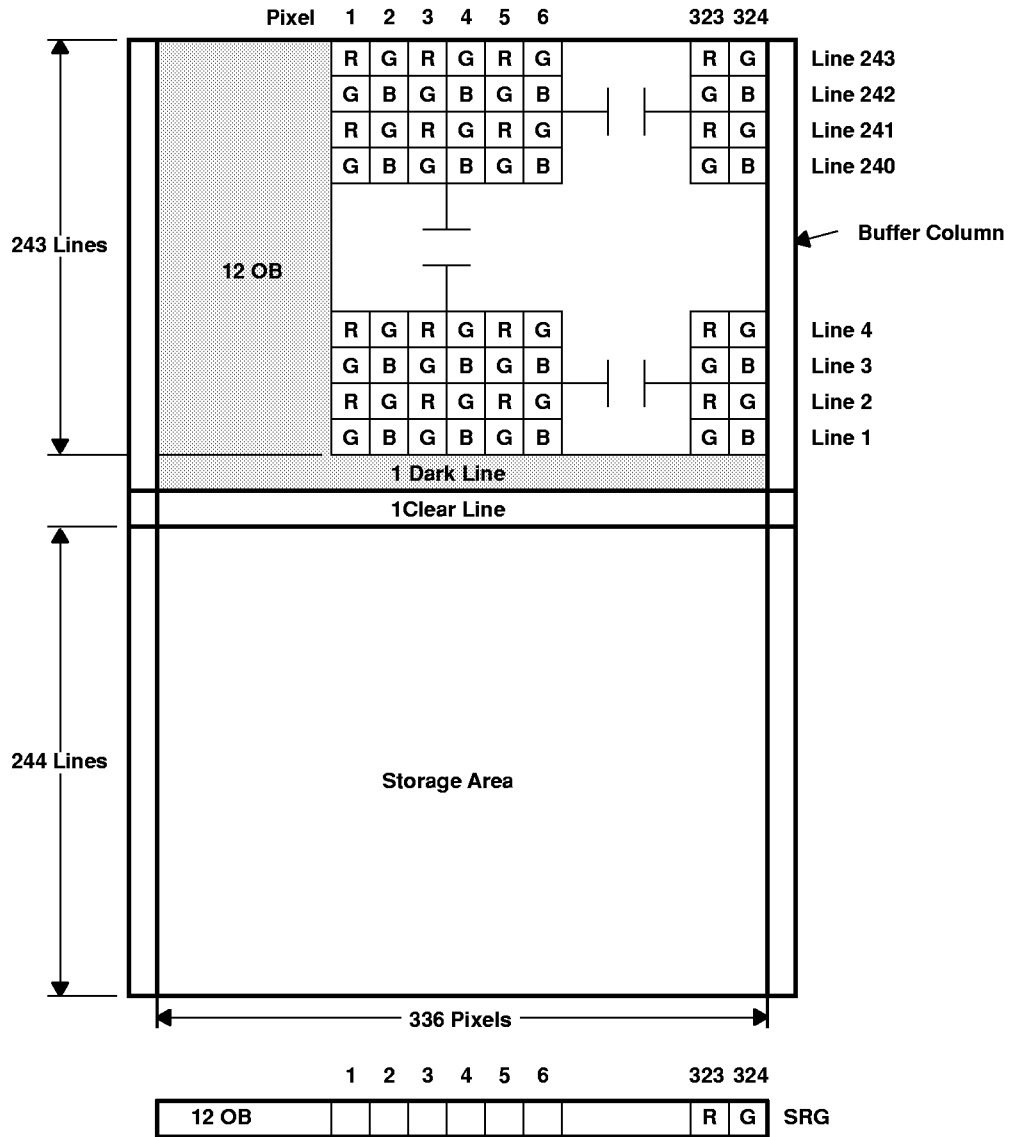

Terminal Functions

TERMINAL NAME	NO.	I/O	DESCRIPTION
ABG	8	I	Antiblooming gate
ADB	2	I	Supply voltage for amplifier-drain bias
SUB	3		Substrate
IAG1	7	I	Image-area gate 1
IAG2	1	I	Image-area gate 2
OUT	4	O	Output
SAG	6	I	Storage-area gate
SRG	5	I	Serial-register gate

TC254P 336- × 244-PIXEL CCD IMAGE SENSOR

SOCS060B – JUNE 1997 – REVISED JULY 1998

detailed description

The TC254P consists of five basic functional blocks: (1) the image-sensing area, (2) the image-clear line, (3) the storage area, (4) the serial register, and (5) the charge-detection node and output amplifier.

image-sensing area

Cross sections with potential well diagrams and top views of image-sensing and storage-area elements are shown in Figure 1 and Figure 2. As light enters the silicon in the image-sensing area, free electrons are generated and collected in the potential wells of the sensing elements. During this time, the antiblooming gate is activated by the application of a burst of pulses every horizontal blanking interval. This prevents blooming caused by the spilling of charge from overexposed elements into neighboring elements. Twelve columns of shielded-from-light elements on the left edge of the image-sensing area generate the dark reference necessary in subsequent video processing circuits for restoration of the video-black level. There is also one column of elements on the right side of the image-sensing area and one line between the image-sensing area and the image-clearing line.

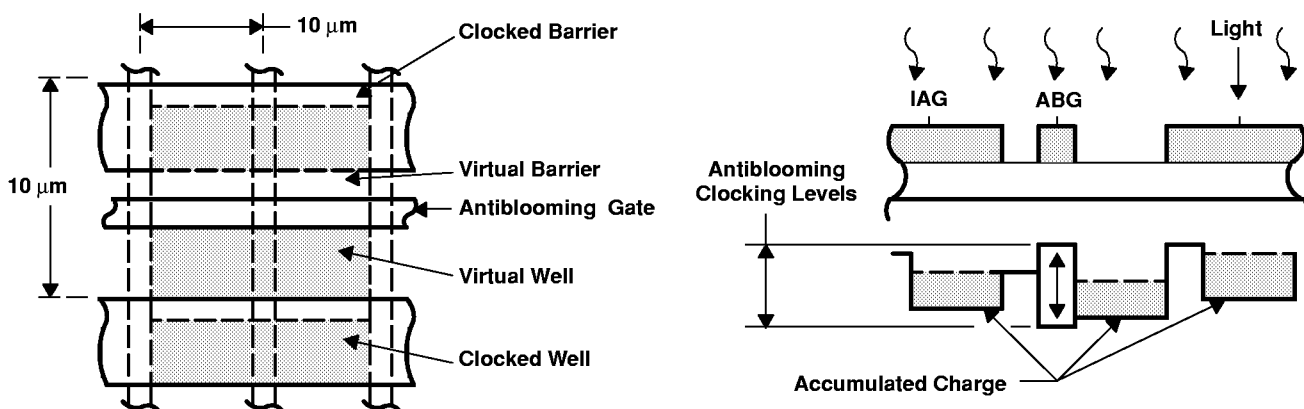

Figure 1. Charge-Accumulation Process

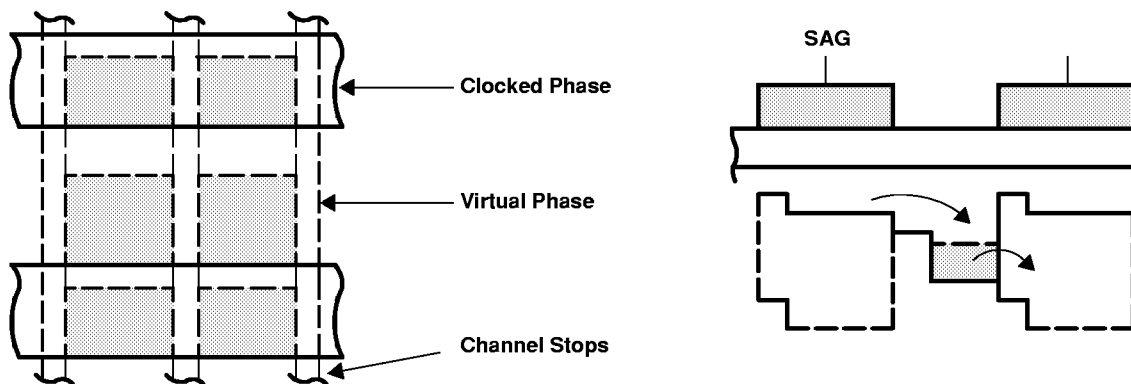

Figure 2. Charge-Transfer Process

image-clear line

During start-up or electronic-shutter operations, it is necessary to clear the image area of charge without transferring it to the storage area. In such situations, the two-image area gates are clocked 244 times without clocking the storage-area gate. The charge in the image area is then cleared through the image-clear line.

storage area

After exposure, the charge captured in each image-area is transferred through the image clear line to the storage area. The stored charge is then transferred line by line into the serial register for readout. Figure 3 illustrates the timing to (1) transfer the image to the storage area, and (2) to transfer each line from the storage area to the serial register.

serial register

Each line, after it is clocked into the serial register, is read out pixel by pixel. Figure 3 illustrates the serial-register clock sequence.

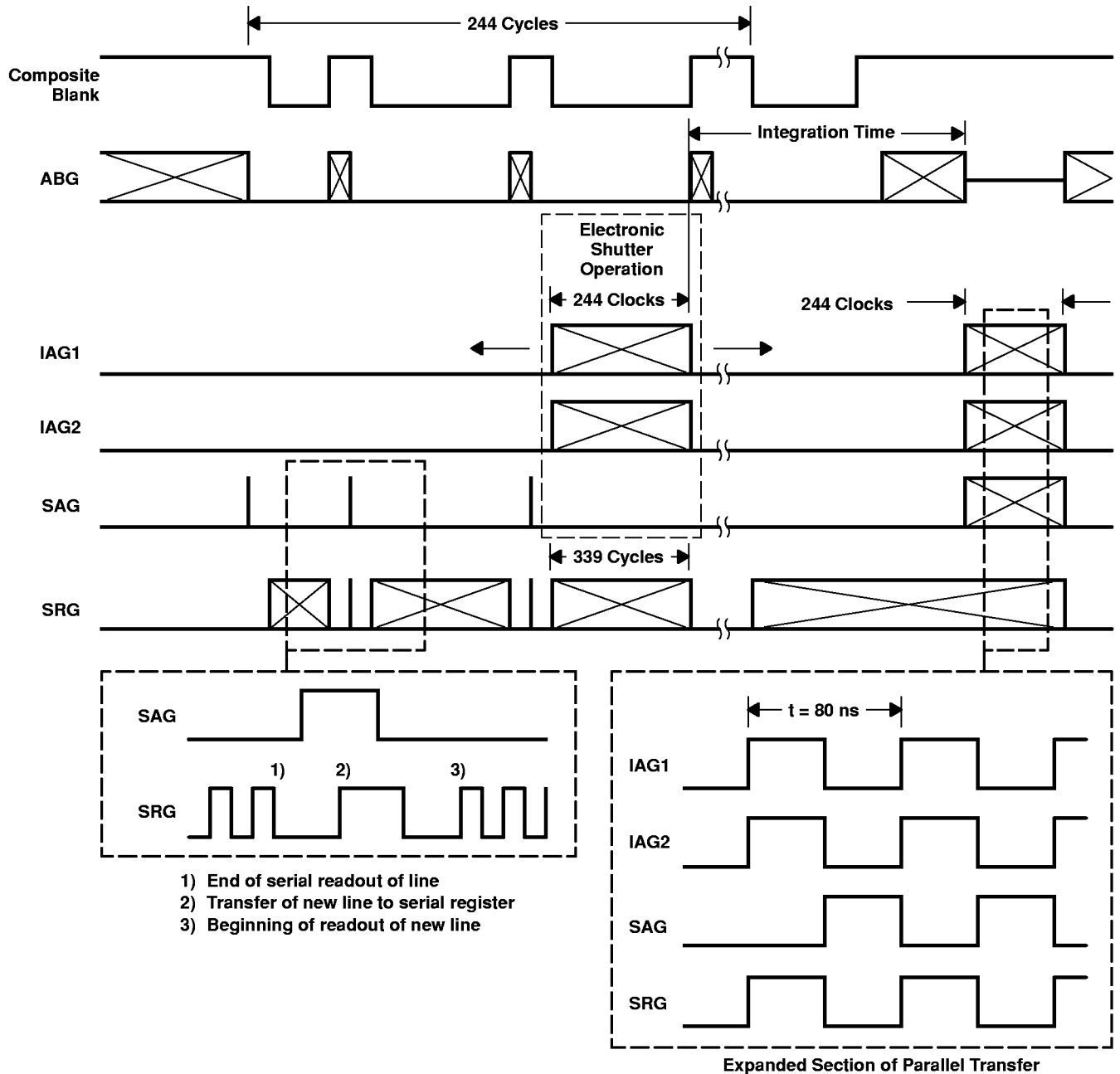

Figure 3. Timing Diagram

spurious-nonuniformity specification

The spurious-nonuniformity specification of the TC254P is based on several sensor characteristics:

- Amplitude of the nonuniform pixel
- Polarity of the nonuniform pixel
 - Black
 - White
- Column amplitude

The CCD sensor is characterized in both an illuminated condition and a dark condition. In the dark condition, the nonuniformity is specified in terms of absolute amplitude, as shown in Figure 5. In the illuminated condition, the nonuniformity is specified as a percentage of the total illumination, as shown in Figure 6.

The specification for the TC254P is as follows:

WHITE SPOT (DARK)	WHITE SPOT (ILLUMINATED)	COLUMN (DARK)	COLUMN (ILLUMINATED)	BLACK SPOT (ILLUMINATED)	WHITE/BLACK† PAIR
$x < 15 \text{ mV}$	$x < 15\%$	$x < 0.5 \text{ mV}$	$x < 1 \text{ mV}$	$x < 15\%$	$x < 9\text{mV}$

† A white/black pair nonuniformity will be no more than 2 pixels even for integration times of 1/60 second.

The conditions under which this specification is defined are as follows:

- The integration time is 1/60 second except for illuminated white spots, illuminated black spots, and white/black pair nonuniformities; in these three cases, the integration time is 1/120 second.
- The temperature is 45°C.
- The CCD video-output signal is $60 \text{ mV} \pm 10 \text{ mV}$.

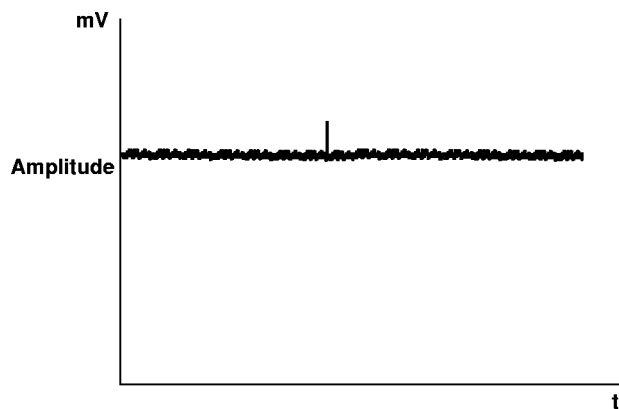

Figure 5. Pixel Nonuniformity, Dark Condition

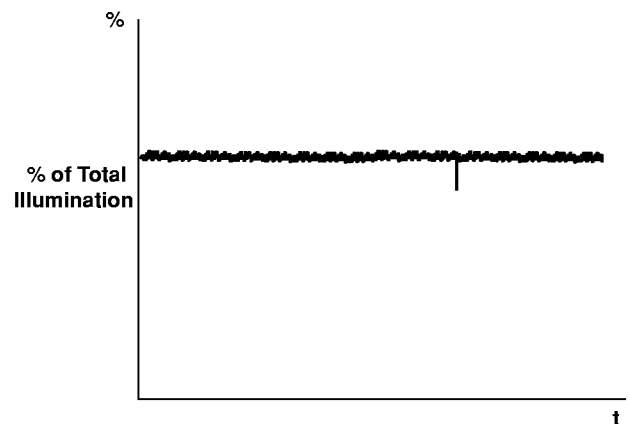

Figure 6. Pixel Nonuniformity, Illuminated Condition

TC254P

336- × 244-PIXEL CCD IMAGE SENSOR

SOCS060B – JUNE 1997 – REVISED JULY 1998

absolute maximum ratings over operating free-air temperature (unless otherwise noted)†

Supply voltage range, V_{CC} : ADB (see Note 1)	0 V to 15 V
Input voltage range, V_I : ABG, IAG1, IAG2, SAG, SRG	-15 V to 15 V
Operating free-air temperature range, T_A	-10°C to 45°C
Storage temperature range, T_{STG}	-30°C to 85°C

† Stresses beyond those listed under "absolute maximum ratings" may cause permanent damage to the device. These are stress ratings only, and functional operation of the device at these or any other conditions beyond those indicated under "recommended operating conditions" is not implied. Exposure to absolute-maximum-rated conditions for extended periods may affect device reliability.

NOTE 1: All voltages are with respect to the substrate terminal.

recommended operating conditions

		MIN	NOM	MAX	UNIT	
Supply voltage, V_{CC}	ADB	11	12	13	V	
Substrate bias voltage			0		V	
Input voltage, V_I	IAG1, IAG2	High level	1.5	2	2.5	V
		Low level	-10.5	-10	-9.5	
	SAG	High level	1.5	2	2.5	
		Low level	-10.5	-10	-9.5	
	SRG	High level	1.5	2	2.5	
		Low level	-10.5	-10	-9.5	
	ABG	High level	3.5	4	4.5	
		Intermediate level‡		-2.5		
		Low level	-8	-7	-6	
Clock frequency, f_{clock}	ABG		6.25	12.5	MHz	
	IAG1, IAG2			25		
	SAG			12.5		
	SRG		6.25	12.5		
Load capacitance	OUT			6	pF	
Plastic package thermal conductivity			0.008		J/cm ² •s•°C	
Operating free-air temperature, T_A		-10		45	°C	

‡ Adjustment is required for optimum performance.



electrical characteristics over recommended operating ranges of supply voltage and free-air temperature (unless otherwise noted)

PARAMETER		MIN	TYP	MAX	UNIT
Dynamic range (see Note 2)	Antiblooming disabled (see Note 3)		66		dB
Charge-conversion factor		11	12	13	μV/e
Charge-transfer efficiency (see Note 4)			0.9999	1	
Signal-response delay time, τ (see Note 5)			20		ns
Gamma (see Note 6)		0.97	0.98	0.99	
Output resistance			350		Ω
Noise-equivalent signal without correlated double sampling			62		electrons
Noise-equivalent signal with correlated double sampling (see Note 7)			31		electrons
Rejection ratio	ADB (see Note 8)	13	15	18	dB
	SRG (see Note 9)		50		
	ABG (see Note 10)		40		
Supply current			5	10	mA
Input capacitance, C _i	IAG1, IAG2		1000		pF
	SRG		22		
	ABG		850		
	SAG		2000		

- NOTES:
2. Dynamic range is –20 times the logarithm of the mean-noise signal divided by saturation-output signal.
 3. For this test, the antiblooming gate must be biased at the intermediate level.
 4. Charge-transfer efficiency is one minus the charge loss per transfer in the output register. The test is performed in the dark using an electrical-input signal.
 5. Signal-response delay time is the time between the falling edge of the SRG pulse and the output-signal valid state.
 6. Gamma (γ) is the value of the exponent in the equation below for two points on the linear portion of the transfer-function curve (this value represents points near saturation).

$$\left(\frac{\text{Exposure (2)}}{\text{Exposure (1)}} \right)^\gamma = \left(\frac{\text{Output signal (2)}}{\text{Output signal (1)}} \right)$$

7. A three-level serial-gate clock is necessary to implement correlated double sampling.
8. ADB rejection ratio is –20 times the logarithm of the ac amplitude at the output divided by the ac amplitude at ADB. See Figure 7 for measured ADB rejection ratio as a function of frequency.
9. SRG rejection ratio is –20 times the logarithm of the ac amplitude at the output divided by the ac amplitude at SRG.
10. ABG rejection ratio is –20 times the logarithm of the ac amplitude at the output divided by the ac amplitude at ABG.

TC254P

336- × 244-PIXEL CCD IMAGE SENSOR

SOCS060B – JUNE 1997 – REVISED JULY 1998

optical characteristics, $T_A = 40^\circ\text{C}$ (unless otherwise noted)

PARAMETER		MIN	TYP	MAX	UNIT
Sensitivity†	Red with CM500 IR filter		9.5		mV/lux
	Green with CM500 IR filter		10		
	Blue with CM500 IR filter		7		
Saturation signal, V_{sat} (see Note 11)	Antiblooming disabled, Interlace off		600	750	mV
Maximum usable signal, V_{use}	Antiblooming enabled		200	250	mV
Blooming-overload ratio (see Note 12)		100	200		
Image-area well capacity		43000	62500		electrons
Smear (see Notes 13 and 14)			0.00012		
Dark current	Interlace disabled, $T_A = 21^\circ\text{C}$		0.20		nA/cm ²
Dark signal			200		μV
Pixel uniformity	Output signal = 60 mV \pm 10 mV		15		mV
Column uniformity	Output signal = 60 mV \pm 10 mV		0.5		mV
Shading			15		%
Electronic-shutter capability		1/15000	1/60		s

† Standard illuminates 2856K

- NOTES: 11. Saturation is the condition in which further increase in exposure does not lead to further increase in output signal.
12. Blooming is the condition in which charge is induced in an element by light incident on another element. Blooming-overload ratio is the ratio of blooming exposure to saturation exposure.
13. Smear is a measure of the error introduced by transferring charge through an illuminated pixel in shutterless operation. It is equivalent to the ratio of the single-pixel transfer time to the exposure time using an illuminated section that is 1/10 of the image area vertical height with recommended clock frequencies.
14. The exposure time is 16.67 ms, the fast-dump clocking rate during vertical transfer is 12.5 MHz, and the illuminated section is 1/10 of the height of the image section.

timing requirements

		MIN	NOM	MAX	UNIT
t_r	Rise time	ABG	10	40	ns
		IAG1, IAG2 (fast clear)	10	10	
		IAG1, IAG2 (image transfer)	10	20	
		SAG	10	20	
		SRG	10	40	
t_f	Fall time	ABG	10	40	ns
		IAG1, IAG2 (fast clear)	10	10	
		IAG1, IAG2 (image transfer)	10	20	
		SAG	10	20	
		SRG	10	40	

PARAMETER MEASUREMENT INFORMATION

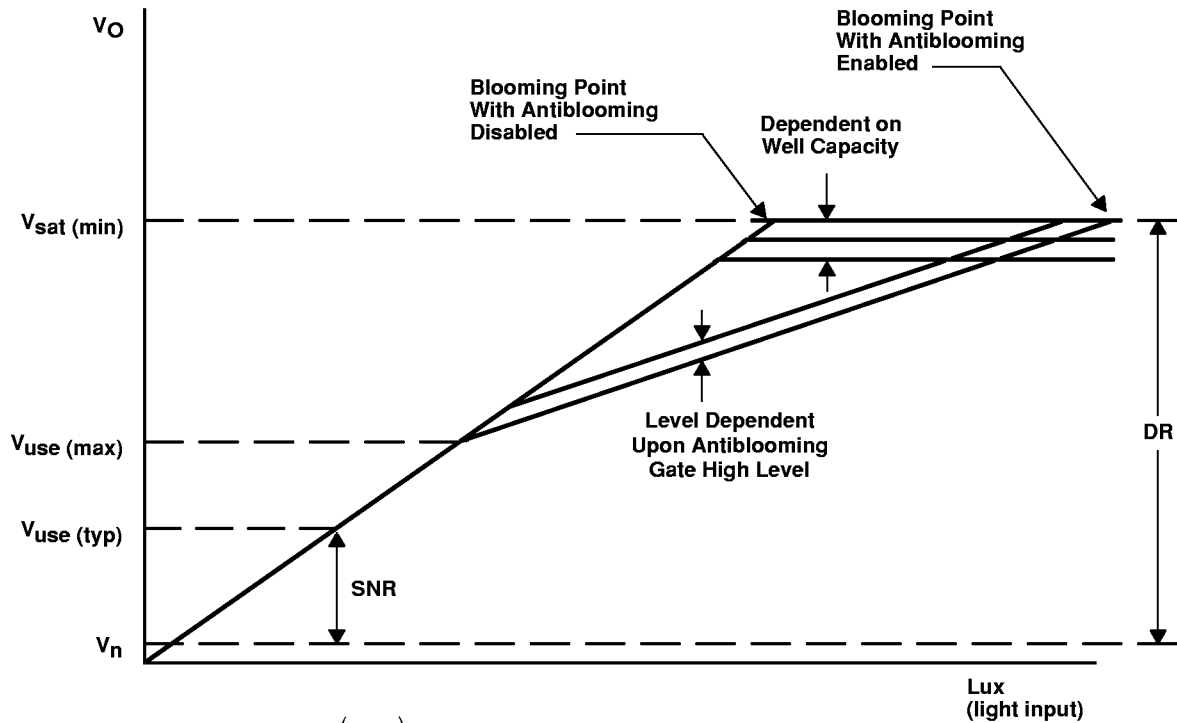

$$DR \text{ (dynamic range)} = 20 \log \frac{(V_{sat})}{V_n} \text{ dB}$$

$$SNR \text{ (signal-to-noise-rate)} = 20 \log \frac{(V_{use})}{V_n} \text{ dB}$$

- V_n = noise-floor voltage
- $V_{sat} \text{ (min)}$ = minimum saturation voltage
- $V_{use} \text{ (max)}$ = maximum usable voltage
- $V_{use} \text{ (typ)}$ = typical user voltage (camera white clip)

- NOTES: A. $V_{use} \text{ (typ)}$ is defined as the voltage determined to equal the camera white clip. This voltage must be less than $V_{use} \text{ (max)}$.
- B. A system trade-off is necessary to determine the system light sensitivity versus the signal/noise ratio. By lowering the $V_{use} \text{ (typ)}$, the light sensitivity of the camera is increased; however, this sacrifices the signal/noise ratio of the camera.

Figure 7. Typical V_{sat} , V_{use} Relationship

TC254P 336- × 244-PIXEL CCD IMAGE SENSOR

SOCS060B – JUNE 1997 – REVISED JULY 1998

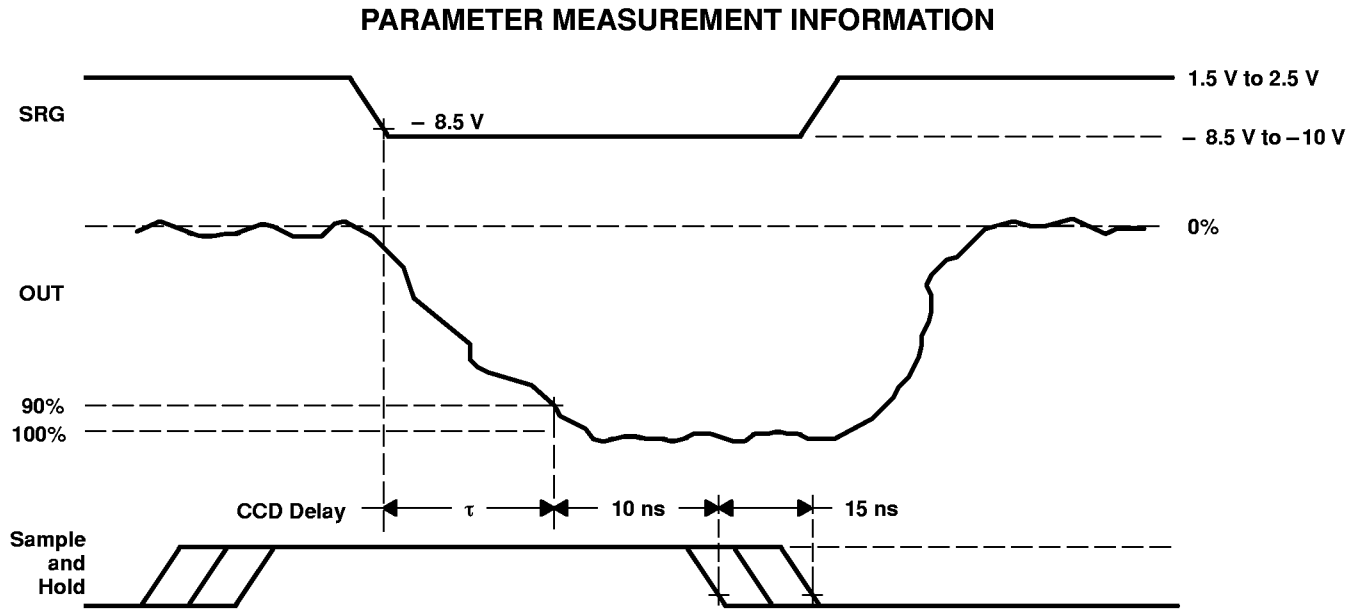
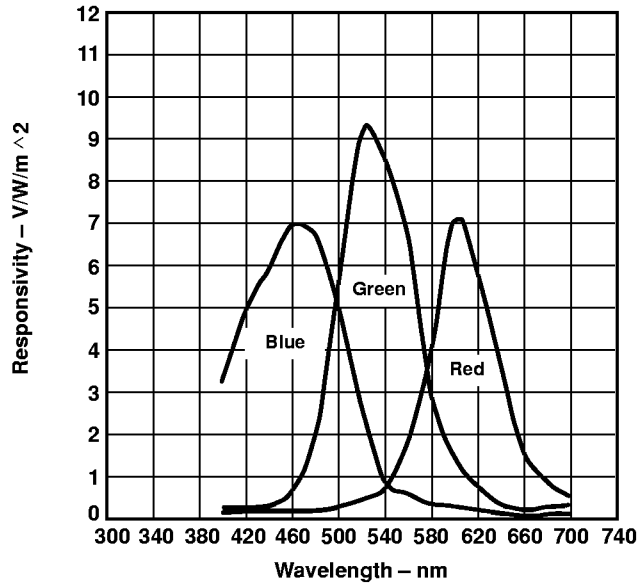

Figure 8. SRG and CCD Output Waveforms

TYPICAL CHARACTERISTICS

TC254 SPECTRAL RESPONSE WITH CM500
TOPPAN DYE COLOR FILTER



TC254P 336- × 244-PIXEL CCD IMAGE SENSOR

SOCS060B – JUNE 1997 – REVISED JULY 1998

APPLICATION INFORMATION

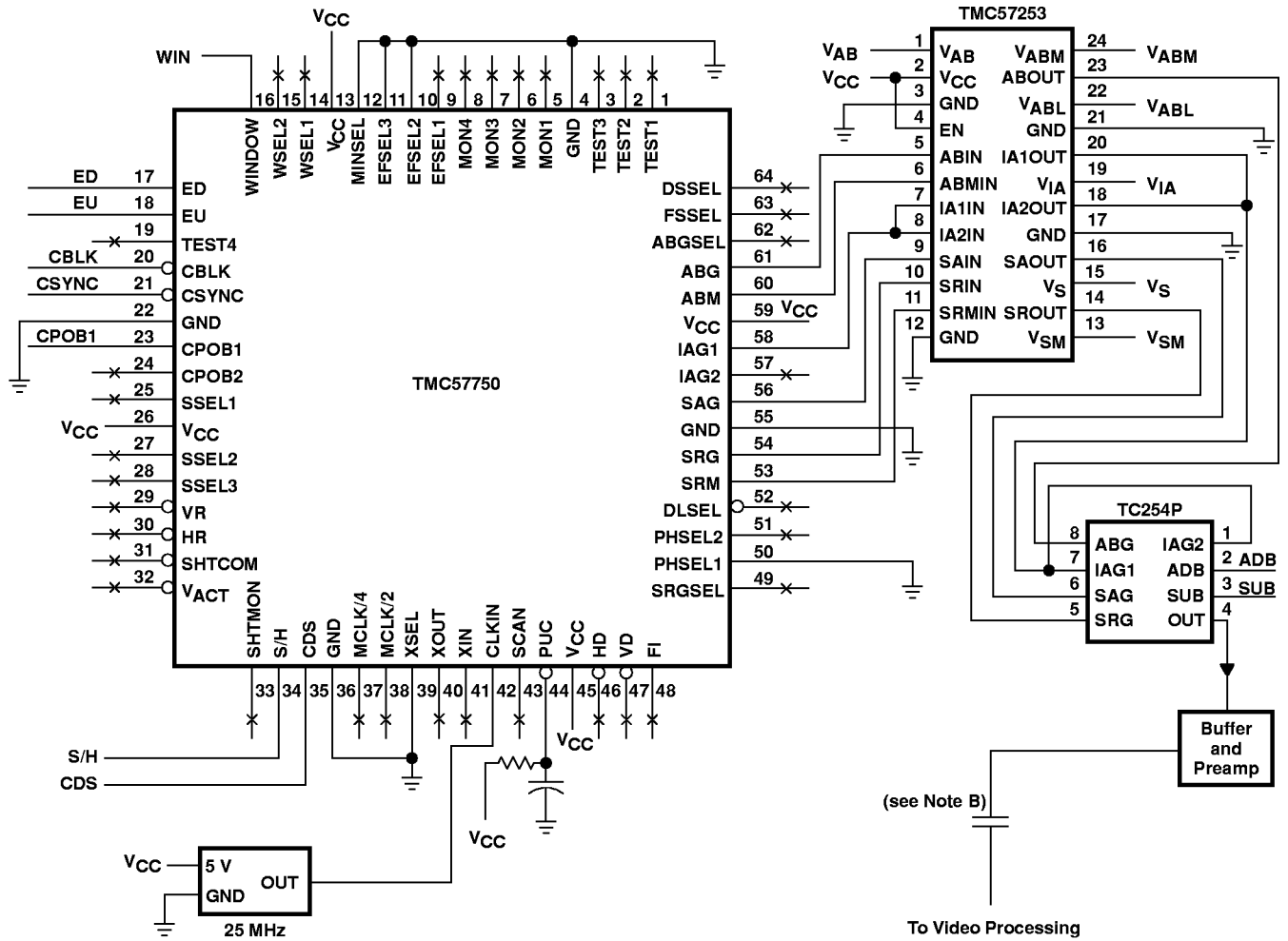

DC VOLTAGES

VIA, VSM, VS	12 V
VCC	5 V
ADB	22 V
SUB	10 V
VABM	7.5 V
VAB	14 V
VABL	3 V

Figure 9. Typical Application Circuit Diagram

- NOTES: A. Decoupling capacitors are not shown.
B. TI recommends designing AC coupled systems.

MECHANICAL DATA

The package for the TC254P consists of a plastic base, a glass window, and an 8-lead frame. The glass window is sealed to the package by an epoxy adhesive. The package leads are configured in a dual in-line organization and fit into mounting holes with 2,54 mm (0.1 in) center-to-center spacings.

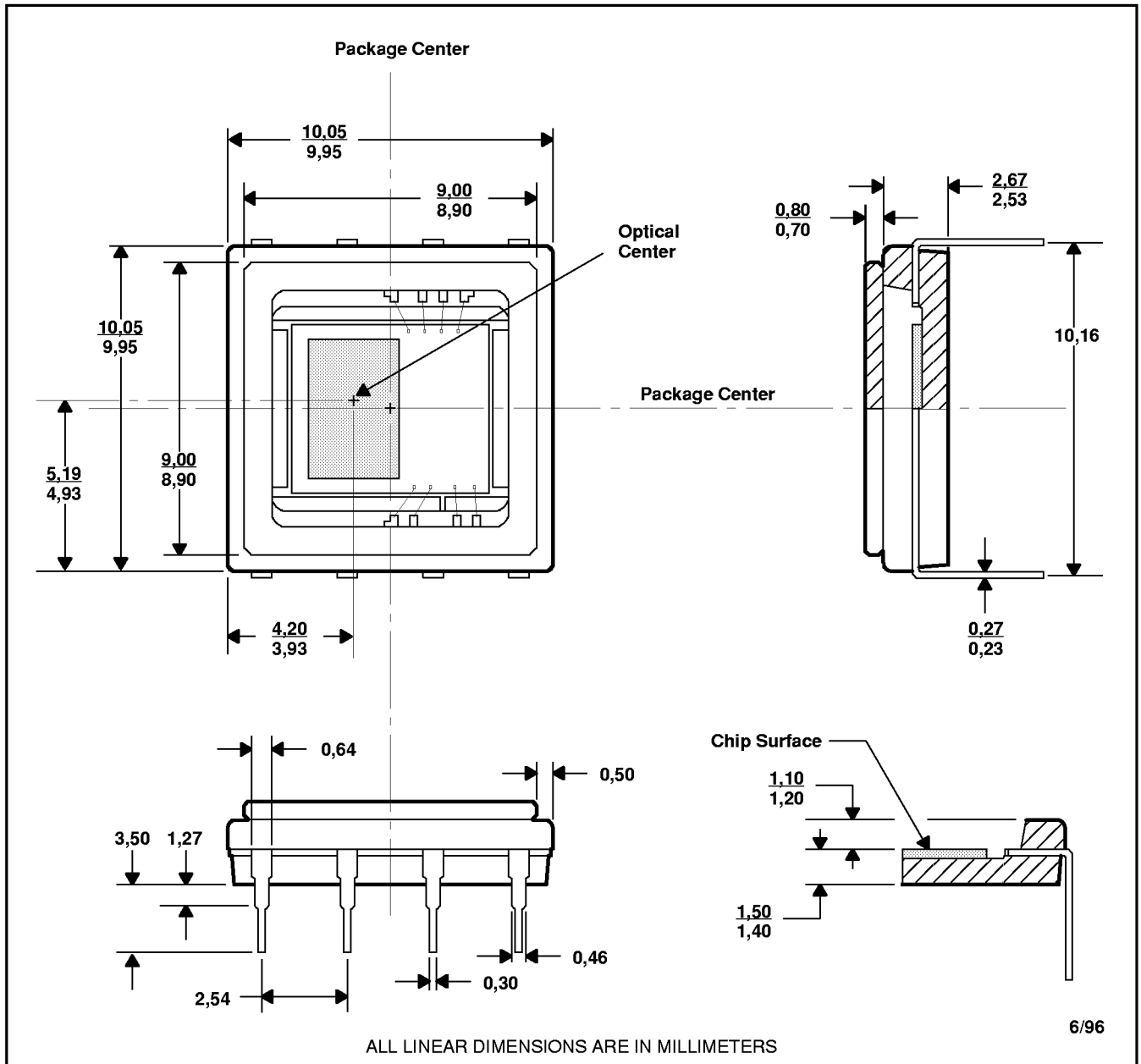

IMPORTANT NOTICE

Texas Instruments and its subsidiaries (TI) reserve the right to make changes to their products or to discontinue any product or service without notice, and advise customers to obtain the latest version of relevant information to verify, before placing orders, that information being relied on is current and complete. All products are sold subject to the terms and conditions of sale supplied at the time of order acknowledgement, including those pertaining to warranty, patent infringement, and limitation of liability.

TI warrants performance of its semiconductor products to the specifications applicable at the time of sale in accordance with TI's standard warranty. Testing and other quality control techniques are utilized to the extent TI deems necessary to support this warranty. Specific testing of all parameters of each device is not necessarily performed, except those mandated by government requirements.

CERTAIN APPLICATIONS USING SEMICONDUCTOR PRODUCTS MAY INVOLVE POTENTIAL RISKS OF DEATH, PERSONAL INJURY, OR SEVERE PROPERTY OR ENVIRONMENTAL DAMAGE ("CRITICAL APPLICATIONS"). TI SEMICONDUCTOR PRODUCTS ARE NOT DESIGNED, AUTHORIZED, OR WARRANTED TO BE SUITABLE FOR USE IN LIFE-SUPPORT DEVICES OR SYSTEMS OR OTHER CRITICAL APPLICATIONS. INCLUSION OF TI PRODUCTS IN SUCH APPLICATIONS IS UNDERSTOOD TO BE FULLY AT THE CUSTOMER'S RISK.

In order to minimize risks associated with the customer's applications, adequate design and operating safeguards must be provided by the customer to minimize inherent or procedural hazards.

TI assumes no liability for applications assistance or customer product design. TI does not warrant or represent that any license, either express or implied, is granted under any patent right, copyright, mask work right, or other intellectual property right of TI covering or relating to any combination, machine, or process in which such semiconductor products or services might be or are used. TI's publication of information regarding any third party's products or services does not constitute TI's approval, warranty or endorsement thereof.