

## CLASS A, 860 MHz, 24 VOLT POWER TRANSISTOR

NEL080120-28  
NEL080220-28  
NEL080525-28

NOT RECOMMENDED FOR NEW DESIGN

### FEATURES

- HIGH LINEAR POWER
- HIGH GAIN
- WIDE BANDWIDTH
- INFINITE VSWR
- 24 VOLT OPERATION:  
NEL0801: 1.2 W  
NEL0802: 2.4 W  
NEL0805: 4.8 W

### DESCRIPTION

NEC's NEL0800 series of NPN epitaxial UHF power transistors is designed for linear operation in the 500 to 1000 MHz UHF band. The series is ideal for low power UHF TV transmitters. The series provides high gain and a high resistance to burnout with load mismatch.

### ELECTRICAL CHARACTERISTICS (T<sub>A</sub> = 25°C)

PART NUMBER EIAJ' REGISTERED NUMBER PACKAGE OUTLINE			NEL080120-28 2SC3139 20			NEL080220-28 2SC3140 20			NEL080525-28 2SC3141 25		
SYMBOLS	PARAMETERS AND CONDITIONS	UNITS	MIN	TYP	MAX	MIN	TYP	MAX	MIN	TYP	MAX
P <sub>TEST</sub>	Output Power at Test Point at V <sub>CE</sub> = 24 V, f = 860 MHz, P <sub>IN</sub> = 20 dBm, I <sub>C</sub> = 200 mA P <sub>IN</sub> = 24 dBm, I <sub>C</sub> = 400 mA P <sub>IN</sub> = 26 dBm, I <sub>C</sub> = 600 mA	dBm dBm dBm	29.5	31		32.3	33.8		35.5	36.8	
P <sub>1dB</sub>	Output Power at 1 dB Compression Point at V <sub>CE</sub> = 24 V, f = 860 MHz, I <sub>C</sub> = 200 mA I <sub>C</sub> = 400 mA I <sub>C</sub> = 600 mA	dBm dBm dBm		33.9			36.3			37.8	
G <sub>1dB</sub>	Gain at 1 dB Compression Point at V <sub>CE</sub> = 24 V, f = 860 MHz, I <sub>C</sub> = 200 mA I <sub>C</sub> = 400 mA I <sub>C</sub> = 600 mA	dB dB dB		10.3			9.3			9	
I <sub>CBO</sub>	Collector Cutoff Current at V <sub>CB</sub> = 30 V, I <sub>E</sub> = 0	mA			0.1			0.2			0.4
I <sub>EBO</sub>	Emitter Cutoff Current at V <sub>EB</sub> = 2 V, I <sub>C</sub> = 0	mA			0.1			0.2			0.4
h <sub>FE</sub>	DC Forward Current Gain at V <sub>CE</sub> = 10 V, I <sub>C</sub> = 150 mA I <sub>C</sub> = 300 mA I <sub>C</sub> = 600 mA		20	60	200	20	100	200	20	100	200
C <sub>OB</sub>	Output Capacitance at V <sub>CB</sub> = 28 V, f = 1 MHz, I <sub>E</sub> = 0,	pF		2	3.5		4	6		8	12
R <sub>TH(J-C)</sub>	Thermal Resistance (Junction to Case)	°C/W			15			10			5.5
P <sub>T</sub>	Total Power Dissipation (T <sub>C</sub> = 25°C)	mW			12			17.5			32

Note:

1. Electronic Industrial Association of Japan.

**NEL080120-28, NEL080220-28, NEL080525-28**

**ABSOLUTE MAXIMUM RATINGS<sup>1</sup> (T<sub>A</sub> = 25°C)**

SYMBOLS	PARAMETERS	UNITS	RATINGS
V <sub>CB0</sub>	Collector to Base Voltage	V	50
V <sub>CE0</sub>	Collector to Emitter Voltage	V	30
V <sub>EB0</sub>	Emitter to Base Voltage	V	3
I <sub>c</sub>	Collector Current	A	
	NEL0801	A	1
	NEL0802	A	2
	NEL0805	A	5
T <sub>J</sub>	Junction Temperature	°C	200
T <sub>STG</sub>	Storage Temperature	°C	-65 to +200

Notes:

1. Operation in excess of any one of these parameters may result in permanent damage.

**TYPICAL PERFORMANCE CURVES (T<sub>A</sub> = 25°C)**

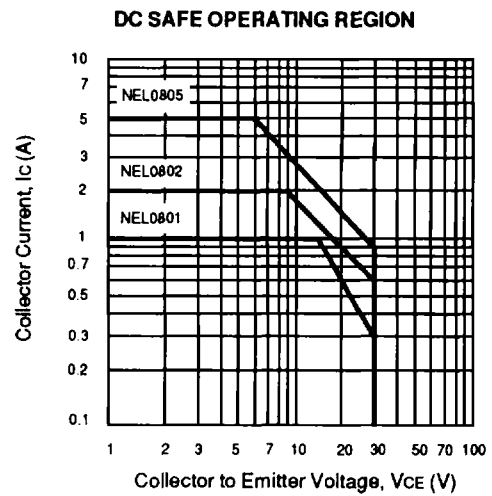
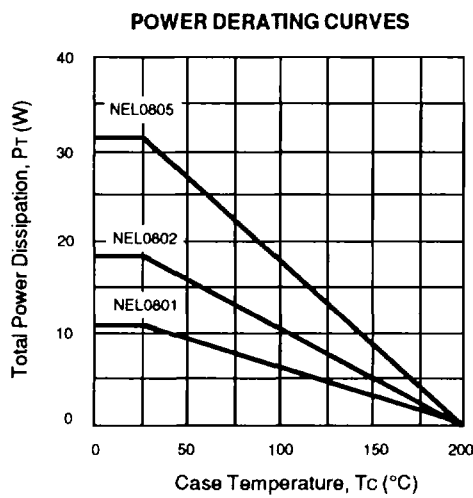

**OUTLINE DIMENSIONS (Units in mm)**

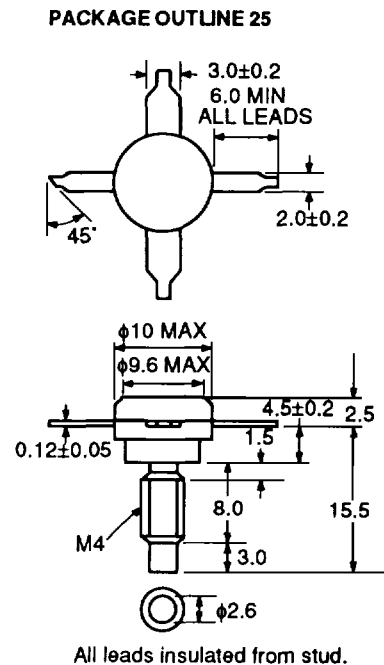
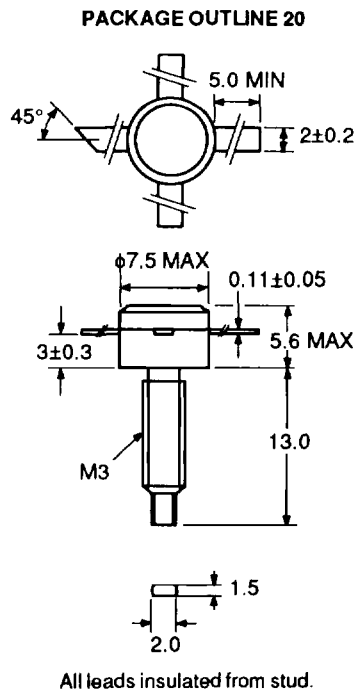

**TYPICAL COMMON EMITTER SCATTERING PARAMETERS** ( $T_A = 25^\circ\text{C}$ )

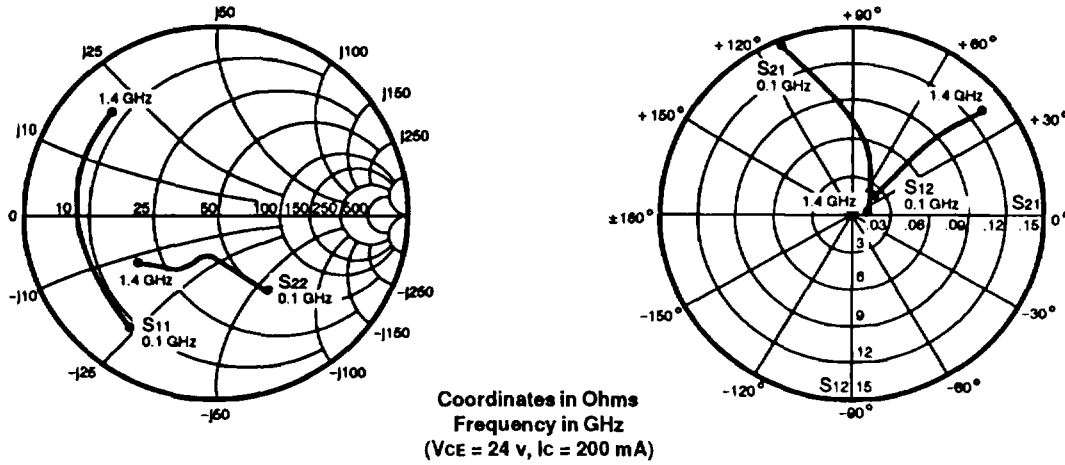

**NEL0801**  
 $V_{CE} = 24\text{ V}$ ,  $I_C = 100\text{ mA}$

FREQUENCY (MHz)	S <sub>11</sub>		S <sub>21</sub>		S <sub>12</sub>		S <sub>22</sub>	
	MAG	ANG	MAG	ANG	MAG	ANG	MAG	ANG
100	.72	-126	15.97	114	.02	39	.52	-64
200	.71	-158	8.62	95	.03	33	.33	-87
400	.73	179	4.58	75	.05	35	.25	-115
600	.74	166	3.05	60	.07	38	.25	-126
800	.74	156	2.31	48	.08	40	.31	-132
1000	.73	150	1.81	38	.10	41	.34	-141
1200	.74	144	1.52	28	.12	39	.36	-145
1400	.77	134	1.32	17	.14	37	.42	-152

$V_{CE} = 24\text{ V}$ ,  $I_C = 200\text{ mA}$

100	.74	-128	14.89	112	.02	38	.49	-59
200	.72	-160	7.92	93	.04	31	.31	-74
400	.74	178	4.19	74	.05	33	.24	-99
600	.74	166	2.79	59	.07	37	.24	-109
800	.75	156	2.11	46	.08	40	.32	-120
1000	.73	150	1.65	35	.10	42	.35	-131
1200	.75	144	1.39	25	.12	41	.38	-136
1400	.78	133	1.21	14	.13	38	.44	-145

4

**TYPICAL COMMON EMITTER SCATTERING PARAMETERS** (TA = 25°C)

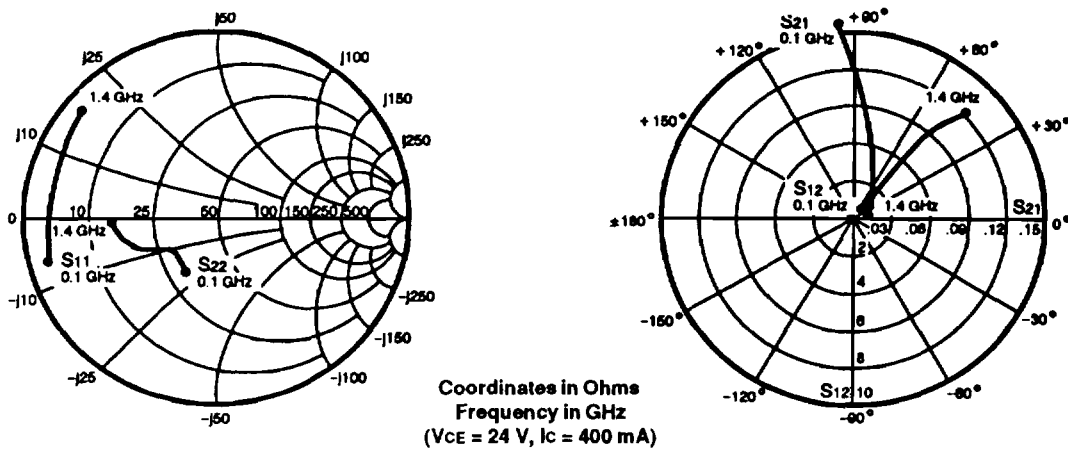

**NEL0802**

VCE = 24V, IC = 300 mA

FREQUENCY (MHz)	S11		S21		S12		S22	
	MAG	ANG	MAG	ANG	MAG	ANG	MAG	ANG
100	.85	-165	12.14	96	.01	26	.37	-134
200	.85	-177	5.97	85	.01	32	.34	-156
400	.87	171	3.09	69	.03	42	.38	-167
600	.87	163	2.02	56	.05	45	.40	-172
800	.86	157	1.53	45	.07	48	.44	-169
1000	.85	153	1.20	35	.09	49	.48	-174
1200	.86	150	1.01	26	.11	45	.48	-179
1400	.89	141	0.88	17	.13	43	.50	-179

VCE = 24 V, IC = 400 mA

100	.86	-166	10.36	95	.01	21	.29	-122
200	.86	-178	5.17	84	.01	34	.27	-143
400	.87	171	2.70	69	.03	40	.34	-156
600	.87	163	1.77	54	.05	46	.37	-162
800	.87	157	1.34	43	.07	50	.43	-161
1000	.85	154	1.04	32	.09	49	.48	-167
1200	.86	149	0.88	22	.10	47	.50	-173
1400	.90	141	0.75	14	.12	44	.51	-179

**TYPICAL COMMON EMITTER SCATTERING PARAMETERS** ( $T_A = 25^\circ\text{C}$ )

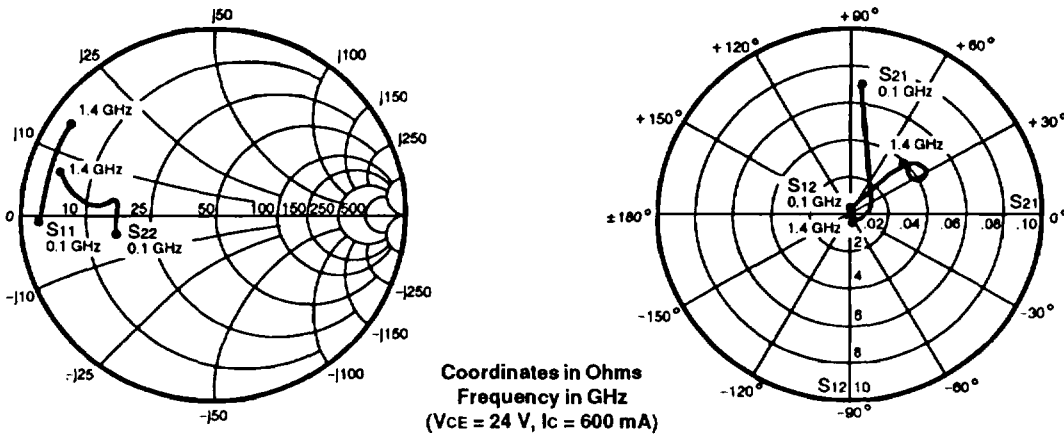

**NEL0805**  
 $V_{CE} = 24\text{ V}$ ,  $I_C = 500\text{ mA}$

FREQUENCY MHz	S <sub>11</sub>		S <sub>21</sub>		S <sub>12</sub>		S <sub>22</sub>	
	MAG	ANG	MAG	ANG	MAG	ANG	MAG	ANG
100	.94	-179	7.33	87	.00	8	.52	-169
200	.94	176	3.64	77	.00	37	.52	-178
400	.95	166	1.97	58	.01	46	.55	177
600	.93	159	1.37	39	.02	42	.56	172
800	.91	153	1.17	21	.03	40	.59	175
1000	.86	150	1.06	-1	.05	33	.64	174
1200	.84	148	1.00	-32	.04	30	.70	171
1400	.91	146	0.81	-78	.04	43	.92	163



$V_{CE} = 24\text{ V}$ ,  $I_C = 600\text{ mA}$

100	.94	-179	7.00	86	.00	15	.52	-169
200	.94	176	3.50	76	.00	38	.52	-178
400	.95	166	1.88	57	.01	41	.55	178
600	.93	159	1.31	38	.03	42	.56	172
800	.91	153	1.11	19	.03	40	.59	175
1000	.86	150	1.00	-3	.05	33	.64	174
1200	.85	149	0.95	-35	.03	28	.71	171
1400	.91	146	0.74	-80	.04	42	.92	162

**TYPICAL INPUT/OUTPUT LOAD IMPEDANCE<sup>1</sup>**

PART NUMBER	f = 500 MHz		f = 700 MHz		f = 860 MHz	
	Z <sub>IN</sub> (Ω)	*Z <sub>L</sub> (Ω)	Z <sub>IN</sub> (Ω)	*Z <sub>L</sub> (Ω)	Z <sub>IN</sub> (Ω)	*Z <sub>L</sub> (Ω)
NEL080120-28	5.8 + j6.1	52 - j41.0	5.8 + j4.3	37 - j48.0	5.84 + j6.9	25 - j43.0
NEL080220-28	2.9 + j7.0	31.1 - j28.0	3.5 + j4.3	26.6 - j27.9	3.2 + j6.6	21.3 - j23.7
NEL080525-28	2.3 + j4.8	18 - j10.5	2.9 + j8.3	14.2 - j5.65	1.5 + j9.7	8.6 - j4.7

Note:

1. Typical Large Signal Impedances at  $V_{CC} = 24\text{ V}$ ,  $T_A = 25^\circ\text{C}$

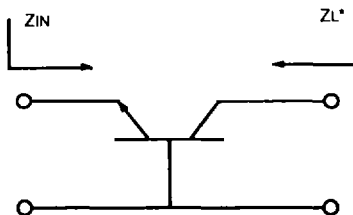

\*Z<sub>L</sub> is optimum load impedance at rated output power.