

## CMOS Dual Precision Monostable Multivibrator

December 1992

### Features

- High-Voltage Type (20V Rating)
- Retriggerable/Resettable Capability
- Trigger and Reset Propagation Delays Independent of  $R_X$ ,  $C_X$
- Triggering From Leading or Trailing Edge
- Q and  $\bar{Q}$  Buffered Outputs Available
- Separate Resets
- Wide Range of Output-Pulse Widths
- Schmitt-Trigger Input Allows Unlimited Rise and Fall Times On +TR and -TR Inputs
- 100% Tested For Maximum Quiescent Current at 20V
- Maximum Input Current of  $1\mu\text{A}$  at 18V Over Full Package-Temperature Range:
  - 100nA at 18V and +25°C
- Noise Margin (Full Package-Temperature Range):
  - 1V at VDD = 5V
  - 2V at VDD = 10V
  - 2.5V at VDD = 15V
- 5V, 10V and 15V Parametric Ratings
- Standardized Symmetrical Output Characteristics
- Meets All Requirements of JEDEC Tentative Standards No. 13B, "Standard Specifications for Description of "B" Series CMOS Device's

### Applications

- Pulse Delay and Timing
- Pulse Shaping

### Description

CD14538BMS dual precision monostable multivibrator provides stable retriggerable/resettable one-shot operation for any fixed-voltage timing application.

An external resistor ( $R_X$ ) and an external capacitor ( $C_X$ ) control the timing and accuracy for the circuit. Adjustment of  $R_X$  and  $C_X$  provides a wide range of output pulse widths from the Q and  $\bar{Q}$  terminals. The time delay from trigger input to output transition (trigger propagation delay) and the time delay from reset input to output transition (reset propagation delay) are independent of  $R_X$  and  $C_X$ . Precision control of output pulse widths is achieved through linear CMOS techniques.

Leading-edge-triggering (+TR) and trailing-edge-triggering (-TR) inputs are provided for triggering from either edge of an input pulse. An unused +TR input should be tied to VSS. An unused -TR input should be tied to VDD. A RESET (on low level) is provided for immediate termination of the output pulse or to prevent output pulses when power is turned on. An unused RESET input should be tied to VDD. However, if an entire section of the CD14538BMS is not used, its inputs must be tied to either VDD or VSS. See Table 1.

In normal operation the circuit retriggers (extends the output pulse one period) on the application of each new trigger pulse. For operation in the non-retriggerable mode,  $\bar{Q}$  is connected to -TR when leading-edge triggering (+TR) is used or Q is connected to +TR when trailing-edge triggering (-TR) is used. The time period (T) for this multivibrator can be calculated by:  $T = R_X C_X$ .

The minimum value of external resistance,  $R_X$  is 4K $\Omega$ . The minimum and maximum values of external capacitance,  $C_X$ , are 0pF and 100 $\mu\text{F}$ , respectively.

The CD14538BMS is interchangeable with type MC14538 and is similar to and pin-compatible with the CD4098B\* and CD4538B\*\*.

\*  $T = 0.5 R_X C_X$  for  $C_X \geq 1000\text{pF}$ .

\*\*  $T = R_X C_X$ ;  $C_X \text{ min} = 5000\text{pF}$ .

The CD14538BMS is supplied in these 16-lead outline packages:

Braze Seal DIP H4X

Frit Seal DIP H1L

Ceramic Flatpack H6W

### Pinout

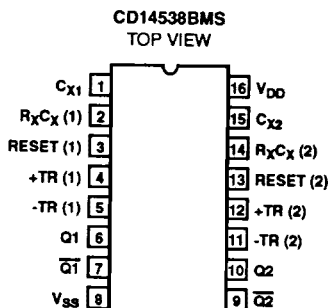

### Functional Diagram

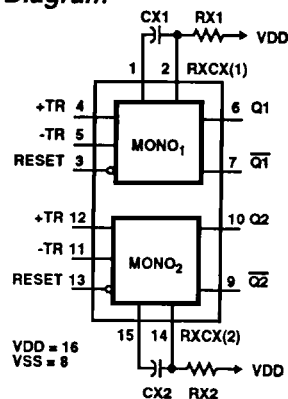

# Specifications CD14538BMS

## Absolute Maximum Ratings

DC Supply Voltage Range, (VDD) .....	-0.5V to +20V (Voltage Referenced to VSS Terminals)
Input Voltage Range, All Inputs .....	-0.5V to VDD +0.5V
DC Input Current, Any One Input .....	±10mA
Operating Temperature Range .....	-55°C to +125°C Package Types D, F, K, H
Storage Temperature Range (TSTG) .....	-65°C to +150°C
Lead Temperature (During Soldering) .....	+265°C At Distance 1/16 ± 1/32 Inch (1.59mm ± 0.79mm) from case for 10s Maximum

## Reliability Information

Thermal Resistance .....	$\theta_{JA}$	$\theta_{JC}$
Ceramic DIP and FRIT Package .....	80°C/W	20°C/W
Flatpack Package .....	70°C/W	20°C/W
Maximum Package Power Dissipation (PD) at +125°C		
For TA = -55°C to +100°C (Package Type D, F, K) .....	500mW	
For TA = +100°C to +125°C (Package Type D, F, K) .....	Derate Linearity at 12mW/°C to 200mW	
Device Dissipation per Output Transistor .....	100mW	
For TA = Full Package Temperature Range (All Package Types)		
Junction Temperature .....	+175°C	

**TABLE 1. DC ELECTRICAL PERFORMANCE CHARACTERISTICS**

PARAMETER	SYMBOL	CONDITIONS (NOTE 1)	GROUP A SUBGROUPS	TEMPERATURE	LIMITS		UNITS	
					MIN	MAX		
Supply Current	IDD	VDD = 20V, VIN = VDD or GND	1	+25°C	-	10	µA	
			2	+125°C	-	1000	µA	
		VDD = 18V, VIN = VDD or GND	3	-55°C	-	10	µA	
Input Leakage Current	IIL	VIN = VDD or GND	VDD = 20	1	+25°C	-100	-	nA
				2	+125°C	-1000	-	nA
			VDD = 18V	3	-55°C	-100	-	nA
Input Leakage Current	IIH	VIN = VDD or GND	VDD = 20	1	+25°C	-	100	nA
				2	+125°C	-	1000	nA
			VDD = 18V	3	-55°C	-	100	nA
Output Voltage	VOL15	VDD = 15V, No Load	1, 2, 3	+25°C, +125°C, -55°C	-	50	mV	
Output Voltage	VOH15	VDD = 15V, No Load (Note 3)	1, 2, 3	+25°C, +125°C, -55°C	14.95	-	V	
Output Current (Sink)	IOL5	VDD = 5V, VOUT = 0.4V	1	+25°C	0.53	-	mA	
Output Current (Sink)	IOL10	VDD = 10V, VOUT = 0.5V	1	+25°C	1.4	-	mA	
Output Current (Sink)	IOL15	VDD = 15V, VOUT = 1.5V	1	+25°C	3.5	-	mA	
Output Current (Source)	IOH5A	VDD = 5V, VOUT = 4.6V	1	+25°C	-	-0.53	mA	
Output Current (Source)	IOH5B	VDD = 5V, VOUT = 2.5V	1	+25°C	-	-1.8	mA	
Output Current (Source)	IOH10	VDD = 10V, VOUT = 9.5V	1	+25°C	-	-1.4	mA	
Output Current (Source)	IOH15	VDD = 15V, VOUT = 13.5V	1	+25°C	-	-3.5	mA	
N Threshold Voltage	VNTH	VDD = 10V, ISS = -10µA	1	+25°C	-2.8	-0.7	V	
P Threshold Voltage	VPTH	VSS = 0V, IDD = 10µA	1	+25°C	0.7	2.8	V	
Functional	F	VDD = 2.8V, VIN = VDD or GND	7	+25°C	VOH > VDD/2	VOL < VDD/2	V	
		VDD = 20V, VIN = VDD or GND	7	+25°C				
		VDD = 18V, VIN = VDD or GND	8A	+125°C				
		VDD = 3V, VIN = VDD or GND	8B	-55°C				
Input Voltage Low (Note 2)	VIL	VDD = 5V, VOH > 4.5V, VOL < 0.5V	1, 2, 3	+25°C, +125°C, -55°C	-	1.5	V	
Input Voltage High (Note 2)	VIH	VDD = 5V, VOH > 4.5V, VOL < 0.5V	1, 2, 3	+25°C, +125°C, -55°C	3.5	-	V	
Input Voltage Low (Note 2)	VIL	VDD = 15V, VOH > 13.5V, VOL < 1.5V	1, 2, 3	+25°C, +125°C, -55°C	-	4	V	
Input Voltage High (Note 2)	VIH	VDD = 15V, VOH > 13.5V, VOL < 1.5V	1, 2, 3	+25°C, +125°C, -55°C	11	-	V	

NOTES: 1. All voltages referenced to device GND, 100% testing being implemented.  
 2. Go/No Go test with limits applied to inputs  
 3. For accuracy, voltage is measured differentially to VDD. Limit is 0.050V max.

7  
LOGIC

# Specifications CD14538BMS

**TABLE 2. AC ELECTRICAL PERFORMANCE CHARACTERISTICS**

PARAMETER	SYMBOL	CONDITIONS (Note 1, 2)	GROUP A SUBGROUPS	TEMPERATURE	LIMITS		UNITS
					MIN	MAX	
Propagation Delay +TR or -TR to Q or $\bar{Q}$	TPHL1 TPLH1	VDD = 5V, VIN = VDD or GND	9	+25°C	-	600	ns
			10, 11	+125°C, -55°C	-	810	ns
Propagation Delay Reset to Q or $\bar{Q}$	TPHL2 TPLH2	VDD = 5V, VIN = VDD or GND	9	+25°C	-	500	ns
			10, 11	+125°C, -55°C	-	675	ns
Transition Time	TTHL TTLH	VDD = 5V, VIN = VDD or GND	9	+25°C	-	200	ns
			10, 11	+125°C, -55°C	-	270	ns

**NOTES:**

1. CL = 50pF, RL = 200K, Input TR, TF < 20ns.
2. -55°C and +125°C limits guaranteed, 100% testing being implemented.

**TABLE 3. ELECTRICAL PERFORMANCE CHARACTERISTICS**

PARAMETER	SYMBOL	CONDITIONS	NOTES	TEMPERATURE	LIMITS		UNITS
					MIN	MAX	
Supply Current	IDD	VDD = 5V, VIN = VDD or GND	1, 2	-55°C, +25°C	-	5	μA
				+125°C	-	150	μA
		VDD = 10V, VIN = VDD or GND	1, 2	-55°C, +25°C	-	10	μA
				+125°C	-	300	μA
		VDD = 15V, VIN = VDD or GND	1, 2	-55°C, +25°C	-	10	μA
				+125°C	-	600	μA
Output Voltage	VOL	VDD = 5V, No Load	1, 2	+25°C, +125°C, -55°C	-	50	mV
Output Voltage	VOL	VDD = 10V, No Load	1, 2	+25°C, +125°C, -55°C	-	50	mV
Output Voltage	VOH	VDD = 5V, No Load	1, 2	+25°C, +125°C, -55°C	4.95	-	V
Output Voltage	VOH	VDD = 10V, No Load	1, 2	+25°C, +125°C, -55°C	9.95	-	V
Output Current (Sink)	IOL5	VDD = 5V, VOUT = 0.4V	1, 2	+125°C	0.36	-	mA
				-55°C	0.64	-	mA
Output Current (Sink)	IOL10	VDD = 10V, VOUT = 0.5V	1, 2	+125°C	0.9	-	mA
				-55°C	1.6	-	mA
Output Current (Sink)	IOL15	VDD = 15V, VOUT = 1.5V	1, 2	+125°C	2.4	-	mA
				-55°C	4.2	-	mA
Output Current (Source)	IOH5A	VDD = 5V, VOUT = 4.6V	1, 2	+125°C	-	-0.36	mA
				-55°C	-	-0.64	mA
Output Current (Source)	IOH5B	VDD = 5V, VOUT = 2.5V	1, 2	+125°C	-	-1.15	mA
				-55°C	-	-2.0	mA
Output Current (Source)	IOH10	VDD = 10V, VOUT = 9.5V	1, 2	+125°C	-	-0.9	mA
				-55°C	-	-1.6	mA
Output Current (Source)	IOH15	VDD = 15V, VOUT = 13.5V	1, 2	+125°C	-	-2.4	mA
				-55°C	-	-4.2	mA
Input Voltage Low	VIL1	VDD = 10V, VOH > 9V, VOL < 1V	1, 2	+25°C, +125°C, -55°C	-	3	V

# Specifications CD14538BMS

**TABLE 3. ELECTRICAL PERFORMANCE CHARACTERISTICS (Continued)**

PARAMETER	SYMBOL	CONDITIONS	NOTES	TEMPERATURE	LIMITS		UNITS
					MIN	MAX	
Input Voltage High	VIH	VDD = 10V, VOH > 9V, VOL < 1V	1, 2	+25°C, +125°C, -55°C	+7	-	V
Propagation Delay +TR OR -TR to Q or $\bar{Q}$	TPHL1 TPLH1	VDD = 10V	1, 2, 3	+25°C	-	300	ns
		VDD = 15V	1, 2, 3	+25°C	-	220	ns
Propagation Delay Reset to Q or $\bar{Q}$	TPHL2 TPLH2	VDD = 10V	1, 2, 3	+25°C	-	250	ns
		VDD = 15V	1, 2, 3	+25°C	-	190	ns
Transition Time	TTHL TTLH	VDD = 10V	1, 2, 3	+25°C	-	100	ns
		VDD = 15V	1, 2, 3	+25°C	-	80	ns
Output Pulse Width Q or $\bar{Q}$ $C_X = .002\mu\text{F}$ , $R_X = 100\text{K}$	TW	VDD = 5V	1, 2, 3	+25°C	-	230	$\mu\text{s}$
		VDD = 10V	1, 2, 3	+25°C	-	232	$\mu\text{s}$
		VDD = 15V	1, 2, 3	+25°C	-	234	$\mu\text{s}$
Output Pulse Width $C_X = 0.1\mu\text{F}$ $R_X = 100\text{K}$	TW	VDD = 5V	1, 2, 3	+25°C	-	10.5	ms
		VDD = 10V	1, 2, 3	+25°C	-	10.6	ms
		VDD = 15V	1, 2, 3	+25°C	-	10.6	ms
Output Pulse Width $C_X = 10\mu\text{F}$ $R_X = 100\text{K}$	TW	VDD = 5V	1, 2, 3	+25°C	-	1.06	s
		VDD = 10V	1, 2, 3	+25°C	-	1.06	s
		VDD = 15V	1, 2, 3	+25°C	-	1.07	s
Minimum Retrigger Time	TRR	VDD = 5V	1, 2, 3	+25°C	0	-	ns
		VDD = 10V	1, 2, 3	+25°C	0	-	ns
		VDD = 15V	1, 2, 3	+25°C	0	-	ns
Minimum Input Pulse Width +TR, -TR, or Reset	TW	VDD = 5V	1, 2, 3	+25°C	-	140	ns
		VDD = 10V	1, 2, 3	+25°C	-	80	ns
		VDD = 15V	1, 2, 3	+25°C	-	60	ns
Input Capacitance	CIN	Any Input	1, 2	+25°C	-	7.5	pF

**NOTES:**

- All voltages referenced to device GND.
- The parameters listed on Table 3 are controlled via design or process and are not directly tested. These parameters are characterized on initial design release and upon design changes which would affect these characteristics.
- CL = 50pF, RL = 200K, Input TR, TF < 20ns.

**TABLE 4. POST IRRADIATION ELECTRICAL PERFORMANCE CHARACTERISTICS**

PARAMETER	SYMBOL	CONDITIONS	NOTES	TEMPERATURE	LIMITS		UNITS
					MIN	MAX	
Supply Current	IDD	VDD = 20V, VIN = VDD or GND	1, 4	+25°C	-	25	$\mu\text{A}$
N Threshold Voltage	VNTH	VDD = 10V, ISS = -10 $\mu\text{A}$	1, 4	+25°C	-2.8	-0.2	V
N Threshold Voltage Delta	$\Delta\text{VNTH}$	VDD = 10V, ISS = -10 $\mu\text{A}$	1, 4	+25°C	-	$\pm 1$	V
P Threshold Voltage	VPTH	VSS = 0V, IDD = 10 $\mu\text{A}$	1, 4	+25°C	0.2	2.8	V
P Threshold Voltage Delta	$\Delta\text{VPTH}$	VSS = 0V, IDD = 10 $\mu\text{A}$	1, 4	+25°C	-	$\pm 1$	V
Functional	F	VDD = 18V, VIN = VDD or GND	1	+25°C	VOH > VDD/2	VOL < VDD/2	V
		VDD = 3V, VIN = VDD or GND					



# Specifications CD14538BMS

**TABLE 8. BURN-IN AND IRRADIATION TEST CONNECTIONS (Continued)**

FUNCTION	OPEN	GROUND	VDD	9V ± 0.5V	OSCILLATOR	
					50kHz	25kHz
Irradiation (Note 2)	2, 6, 7, 9, 10, 14	1, 8, 15	3 - 5, 11 - 13, 16			

NOTE:

1. Each pin except VDD and GND will have a series resistor of 10K ± 5%, VDD = 18V ± 0.5V
2. Each pin except VDD and GND will have a series resistor of 47K ± 5%; Group E, Subgroup 2, sample size is 4 dice/wafer, 0 failures, VDD = 10V ± 0.5V

**TABLE 9. FUNCTIONAL TERMINAL CONNECTIONS**

FUNCTION	VDD TO TERM #		VSS TO TERM #		INPUT PULSE TO TERM #		OTHER CONNECTIONS	
	MONO1	MONO2	MONO1	MONO2	MONO1	MONO2	MONO1	MONO2
Leading-Edge Trigger/ Retriggerable	3, 5	11, 13			4	12		
Leading-Edge Trigger/ Non-Retriggerable	3	13			4	12	5 - 7	11 - 9
Trailing-Edge Trigger/ Retriggerable	3	13	4	12	5	11		
Trailing-Edge Trigger/ Non-Retriggerable	3	13			5	11	4 - 6	12 - 10

NOTE:

1. A triggerable one-shot multivibrator has an output pulse width which is extended one full time period (T) after application of the last trigger pulse.
2. A non-triggerable one-shot multivibrator has a time period (T) referenced from the application of the first trigger pulse.

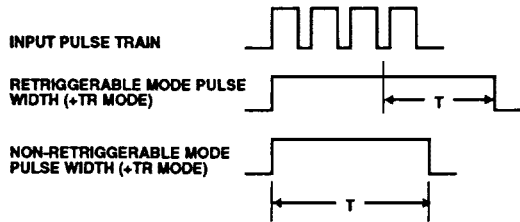

## Power-Down Mode

During a rapid power-down condition, as would occur with a power-supply short circuit or with a poorly filtered power supply, the energy stored in  $C_X$  could discharge into Pin 2 or 14. To avoid possible device damage in this mode, when  $C_X$  is  $\geq 0.5$  microfarad, a protection diode with a 1-ampere or higher rating (1N5395 or equivalent) and a separate ground return for  $C_X$  should be provided as shown in Figure 1.

An alternate protection method is shown in Figure 2, where a 51-ohm current-limiting resistor is inserted in series with  $C_X$ . Note that a small pulse width decrease will occur however, and  $R_X$  must be appropriately increased to obtain the originally desired pulse width.

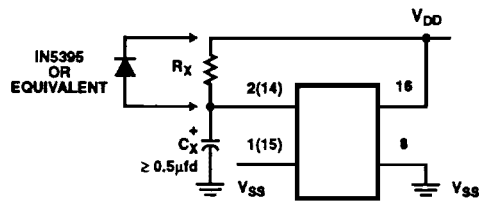

**FIGURE 1. RAPID POWER-DOWN PROTECTION CIRCUIT**

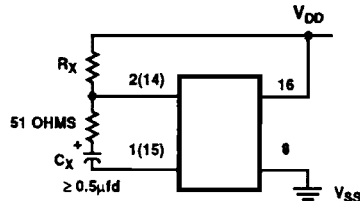

**FIGURE 2. ALTERNATE RAPID POWER-DOWN PROTECTION CIRCUIT**

Logic Diagram

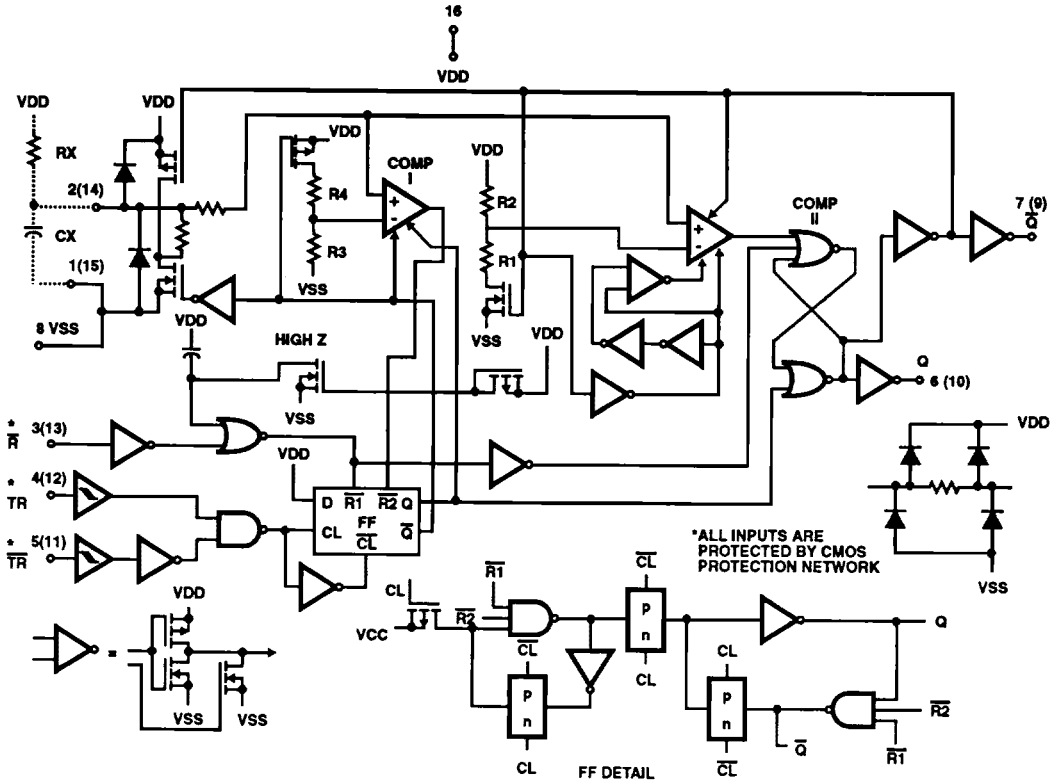

FIGURE 3. 1/2 OF DEVICE SHOWN

Typical Performance Characteristics

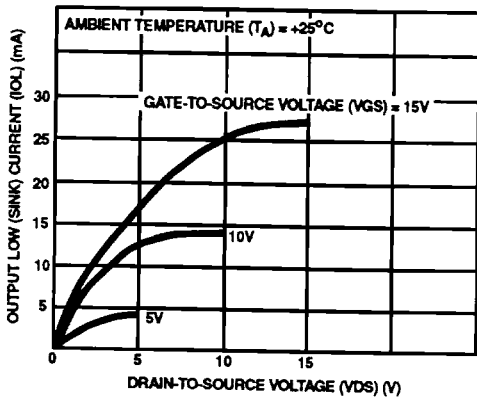

FIGURE 4. TYPICAL OUTPUT LOW (SINK) CURRENT CHARACTERISTICS

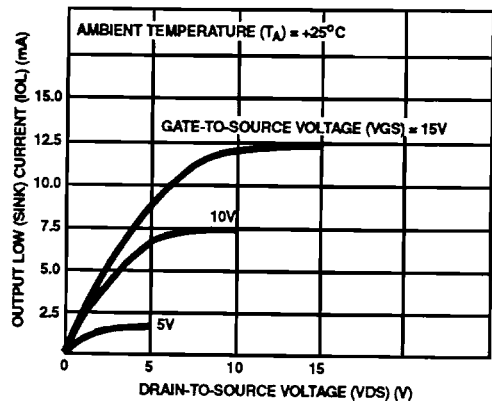

FIGURE 5. MINIMUM OUTPUT LOW (SINK) CURRENT CHARACTERISTICS

Typical Performance Characteristics (Continued)

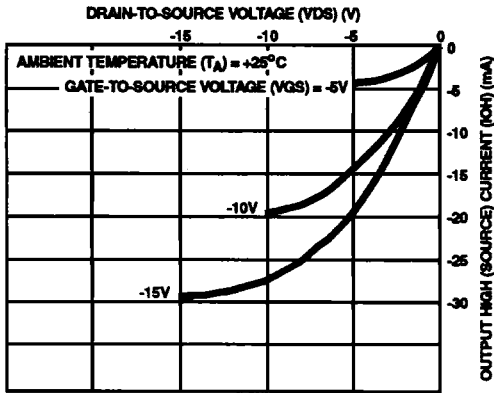

FIGURE 6. TYPICAL OUTPUT HIGH (SOURCE) CURRENT CHARACTERISTICS

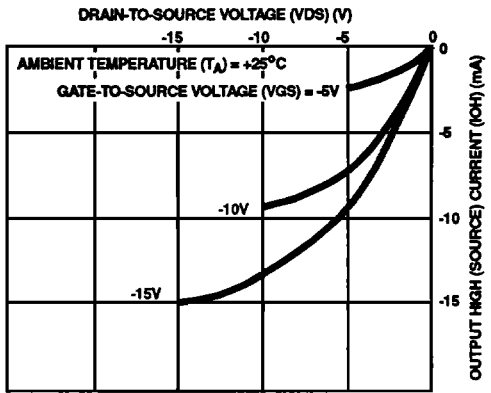

FIGURE 7. MINIMUM OUTPUT HIGH (SOURCE) CURRENT CHARACTERISTICS

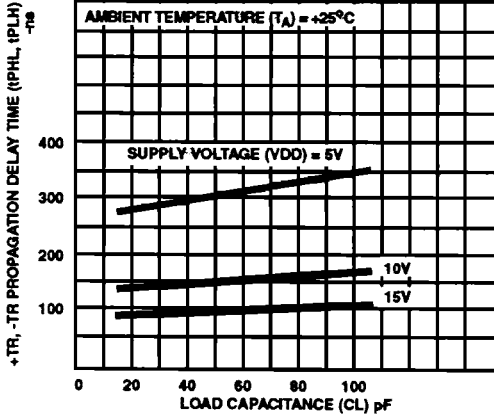

FIGURE 8. TYPICAL PROPAGATION DELAY TIME AS A FUNCTION OF LOAD CAPACITANCE (+TR OR -TR TO Q OR Q̄)

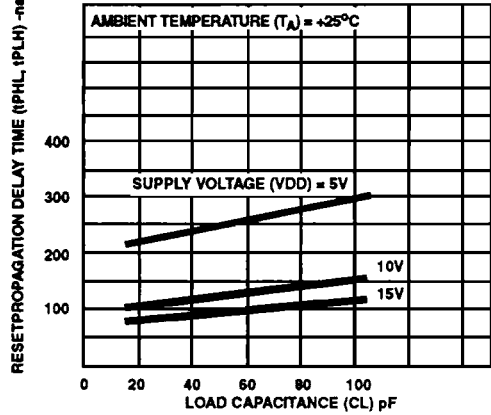

FIGURE 9. TYPICAL PROPAGATION DELAY TIME AS A FUNCTION OF LOAD CAPACITANCE (RESET TO Q OR Q̄)

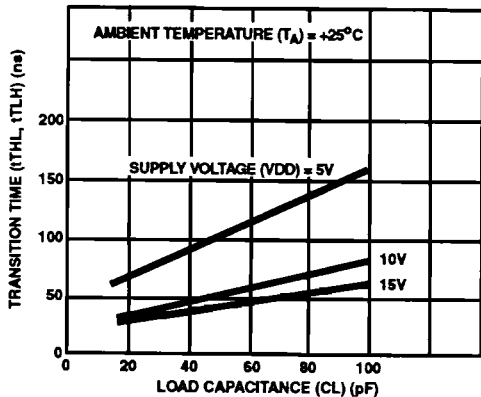

FIGURE 10. TYPICAL TRANSITION TIME AS A FUNCTION OF LOAD CAPACITANCE

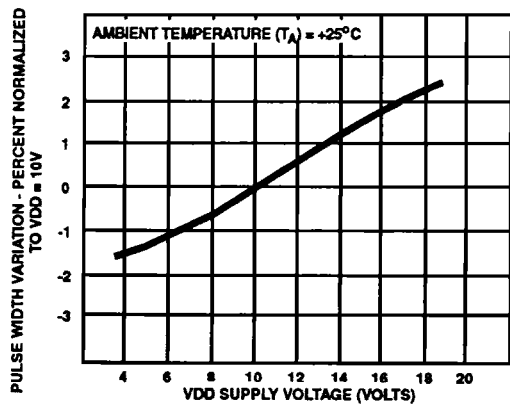

FIGURE 11. TYPICAL PULSE-WIDTH VARIATION AS A FUNCTION OF SUPPLY VOLTAGE

Typical Performance Characteristics (Continued)

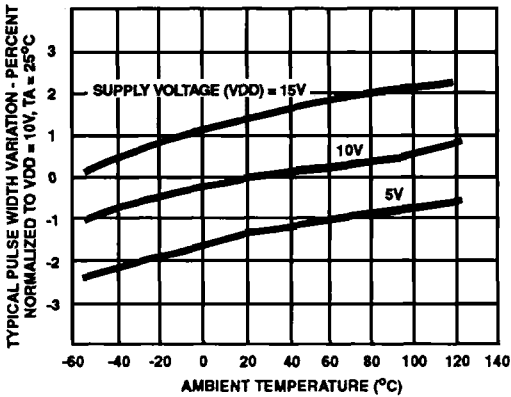

FIGURE 12. TYPICAL PULSE-WIDTH VARIATION AS A FUNCTION OF TEMPERATURE (RX = 100 KΩ, CX = 0.1μF)

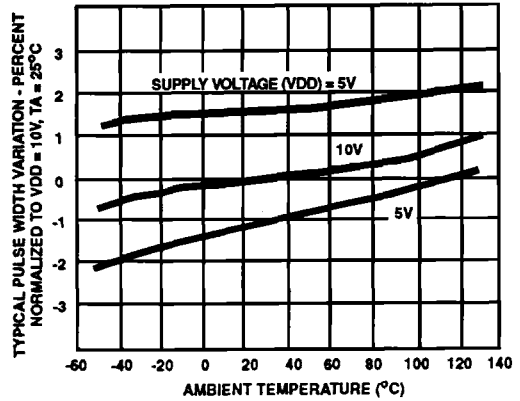

FIGURE 13. TYPICAL PULSE-WIDTH VARIATION AS A FUNCTION OF TEMPERATURE (RX = 100 KΩ, CX = 2000pF)

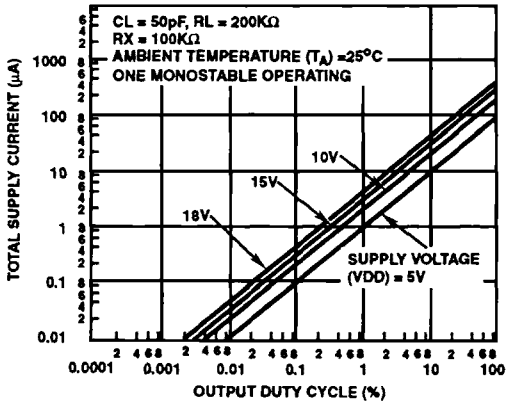

FIGURE 14. TYPICAL TOTAL SUPPLY CURRENT AS A FUNCTION OF OUTPUT DUTY CYCLE

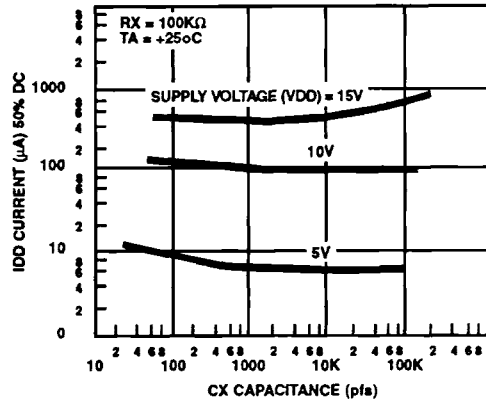
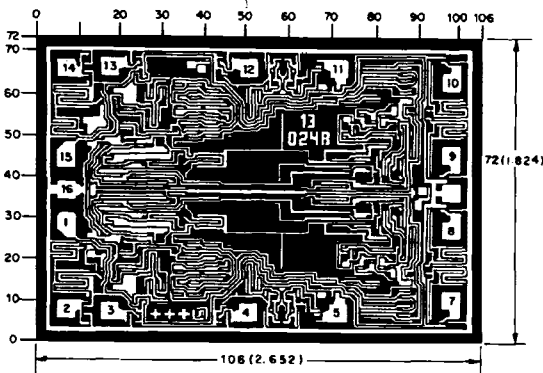

FIGURE 15. TYPICAL TOTAL SUPPLY CURRENT AS A FUNCTION OF LOAD CAPACITANCE

Chip Dimension and Pad Layout



- METALLIZATION: Thickness: 11kÅ - 14kÅ, AL
- PASSIVATION: 10.4kÅ - 15.6kÅ, Silane
- BOND PADS: 0.004 inches X 0.004 inches MIN
- DIE THICKNESS: 0.0198 inches - 0.0218 inches

Dimensions in parentheses are in millimeters and are derived from the basic inch dimensions as indicated. Grid graduations are in mils (10<sup>-3</sup> inch)