

Dual-Modulus Divider 1:64/65 for 1 GHz with Standby Operation

TBB 212 A

Preliminary Data

Bipolar IC

Features

- High frequency operation: $f_{\max} = 1100$ MHz
- Pulse swallow function: 64/65
- Low power supply current: 8.5 mA typ.
 $V_S = 3$ V
- Stable output amplitude: $V_O = 1.0$ Vpp typ.
- Stable output amplitude is obtained
load capacitance of 15 pF.

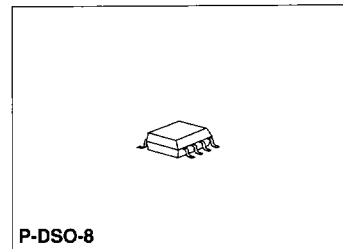
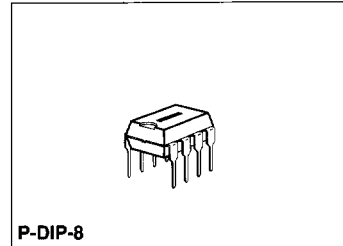

Type	Ordering Code	Package
TBB 212 A	Q67000-H8760	P-DIP-8
TBB 212 AG	Q67000-H8761	P-DSO-8 (SMD)

The TBB 212 is specially intended for applications in radiotelephones. It contains several ECL divider stages, which have a total divider ratio of 1:64/65, depending on the control of the MOD input. It can be employed in standby mode (input STB = low). The IC is particular intended for GSM.

Circuit Description

The divider has balanced push-pull inputs. It is driven unbalanced, the unused input has to be blocked by a capacitor (approx. 1.5 nF) with low series inductance. The divider of the component consists of several status-controlled master-slave flipflops, which have a total divider ratio of 1: 64/65. The MOD inputs (divider ratio changeover input) and STB (input for standby mode) are controllable with TTL/CMOS levels. The ECL output of the divider is CMOS compatible (**see application circuit**). The typical swing is 1 Vpp.

Truth Table for Operating Modes

Input	Level	Function at Q
MOD	High or unwired ¹⁾ low	1:64 1:65
STB	High or unwired ¹⁾ low	Normal Q = high, standby

Pin Configurations (top view)

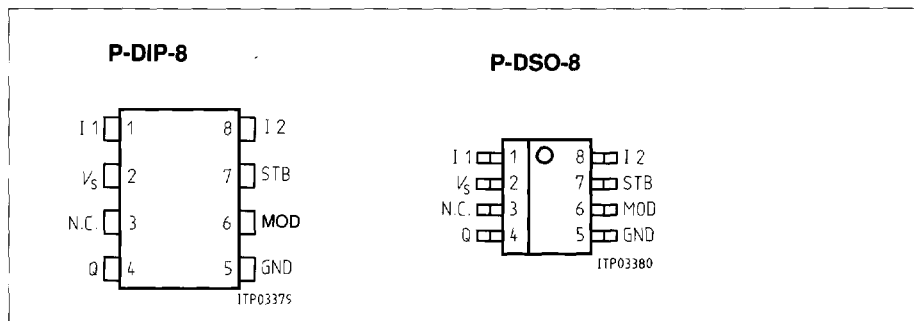

Pin Definitions and Functions

Pin No.	Symbol	Function
1	I1	Input
2	V _s	Supply voltage
3	N.C.	Not connected
4	Q	Output
5	GND	Ground
6	MOD	Input for control of divider ratio
7	STB	Input for standby mode
8	I2	Input

¹⁾ External circuitry increase noise immunity

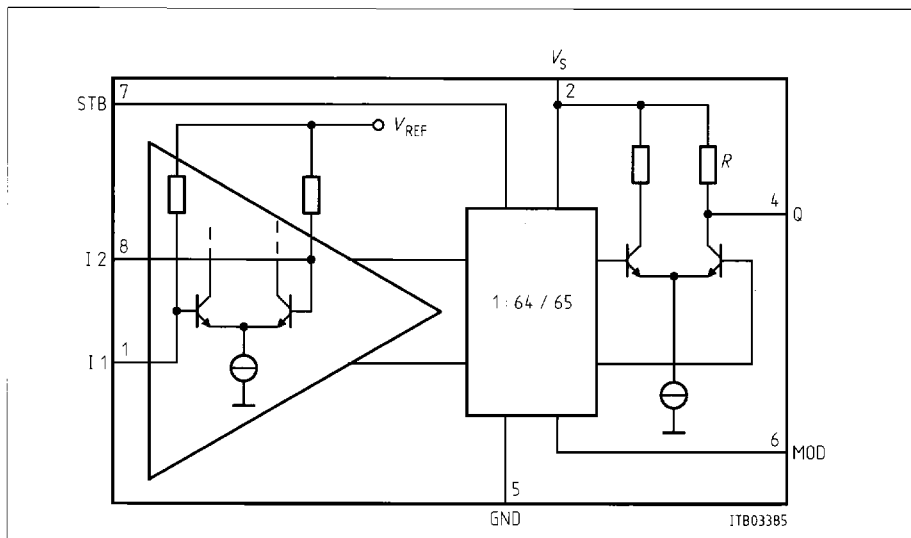

Block Diagram

Absolute Maximum Ratings

$T_A = -40\text{ }^\circ\text{C}$ to $85\text{ }^\circ\text{C}$

Parameter	Symbol	Limit Values		Unit
		min.	max.	
Supply voltage	V_S	-0.3	6	V
Input voltage (pin 1; pin 8)	V_I	-0.3	2.5	V
Input voltage (pin 6; pin 7)	V_{MOD}, V_{STB}	-0.3	6	V
Output voltage (pin 4)	V_O		V_S	V
Output current (pin 4)	$-I_O$		10	mA
Junction temperature	T_j		125	$^\circ\text{C}$
Storage temperature	T_{stg}	-65	125	$^\circ\text{C}$
Thermal resistance system – air P-DIP-8 P-DSO-8	$R_{th SA}$ $R_{th SA}$		105 185	K/W K/W

Operating Range

Supply voltage	V_S	3.0	5.5	V
Input frequency	f	140	1100	MHz
Ambient temperature	T_A	-40	85	$^\circ\text{C}$

Characteristics

$V_s = 3.0\text{ V to }5.5\text{ V}$, $T_A = -40\text{ °C to }85\text{ °C}$, refer to test circuit

Parameter	Symbol	Limit Values			Unit	Test Condition
		min.	typ.	max.		
Current consumption in operation	I_s		8.5		mA	Inputs blocked STB open, no load $T_A = 25\text{ °C}$ $V_s = 3\text{ V}$ $V_s = 4\text{ V}$ $V_s = 5\text{ V}$
	I_s		9.5	12.8	mA	
	I_s		10.5	13.5	mA	
in standby	I_s		1.5		mA	Output n.c. STB = GND Inputs blocked
Input level (input sensitivity)	V_I	10		100	mVrms	140 MHz (sine voltage)
		5		100	mVrms	400 MHz
		5		100	mVrms	600 MHz
		5		100	mVrms	800 MHz
		7		100	mVrms	900 MHz
		10		100	mVrms	1000 MHz

MOD Input

Switching threshold	V_I		0.7		V	
H-input current	I_{IH}		0	50	μA	MOD = V_s (1: 64)
L-input current	$-I_{IL}$		110	210	μA	MOD = ground (1: 65)

Standby Input

Switching threshold	V_{STB}		0.7		V	
H-input current	I_{IH}		0	50	μA	STB = V_s
L-input current	$-I_{IL}$		100	200	μA	STB = ground

Output

Output voltage swing	V_O		1		Vpp	$C_L \leq 15\text{ pF}$
Output resistance	R		1		k Ω	

Switching Times

Setup time	t_V			24	ns	
------------	-------	--	--	----	----	--

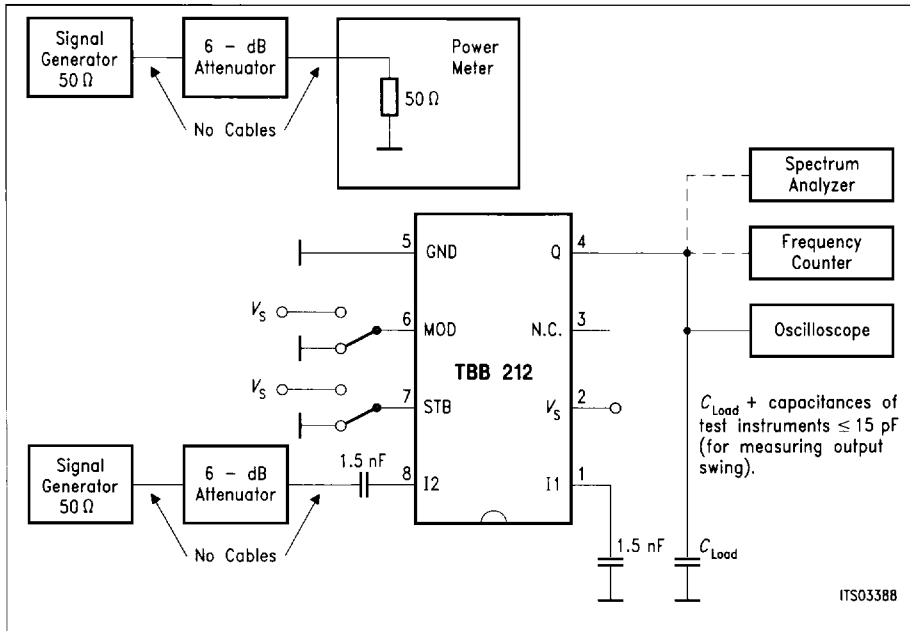

Test Circuit

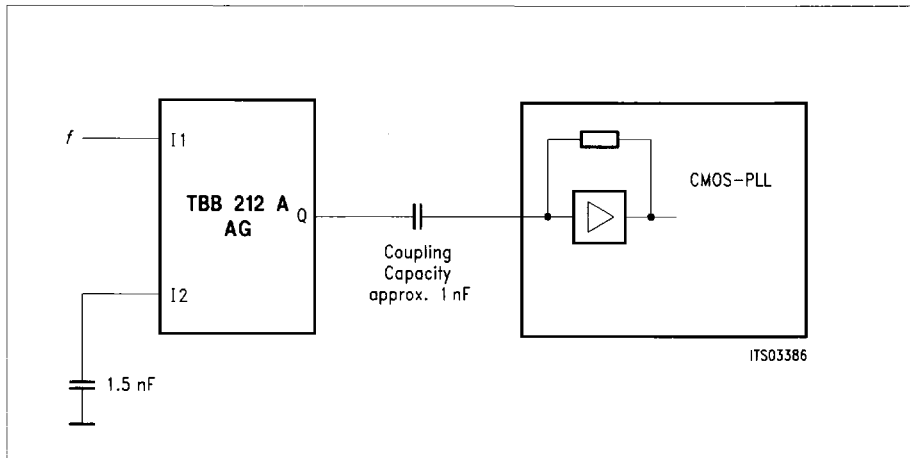

Application Circuit

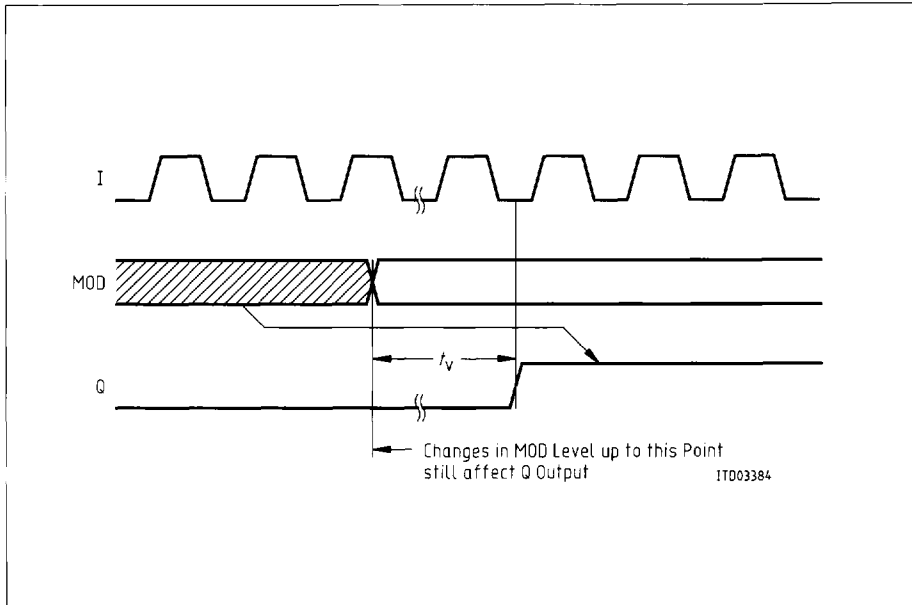

Diagram