



actual size

Quartz Crystal · JTX310

SMD Tuning Fork Crystal · 3.2 x 1.5 mm

- 32.768 kHz
- reflow soldering temperature: 260 °C max.
- package height 0.9 mm max.



General Data

type	JTX310
frequency	32.768 kHz
frequency tolerance at 25 °C ± 5 °C	± 10 ppm / ± 20 ppm / ± 30 ppm
load capacitance C_L	12.5 pF std. (6 pF ~ 9 pF on request)
temperature constant (T_C)	$T_C = -0.04 \cdot 10^{-6} / ^\circ C^2$ max. $T_C = -0.034 \cdot 10^{-6} / ^\circ C^2$ typical
frequency temperature characteristic	f (ppm) = $T_C \cdot (25^\circ C - T)^2$ T = requested temperature
operating temperature range	-20 °C ~ +70 °C / -40 °C ~ +85 °C
shunt capacitance C_0	1.15 pF typical
series resistance max. (ESR)	70 k Ω (60 k Ω ask if available)
storage temperature	-40 °C ~ +90 °C
drive level max.	0.5 μ W
aging first year	< ± 3 ppm

Frequency Stability vs. Temperature

		- 80 ppm	- 160 ppm	
-20 °C ~ +70 °C	STD.	●		
-40 °C ~ +85 °C	T1		●	
● standard				

Marking

company code
date code / production code

Dimensions

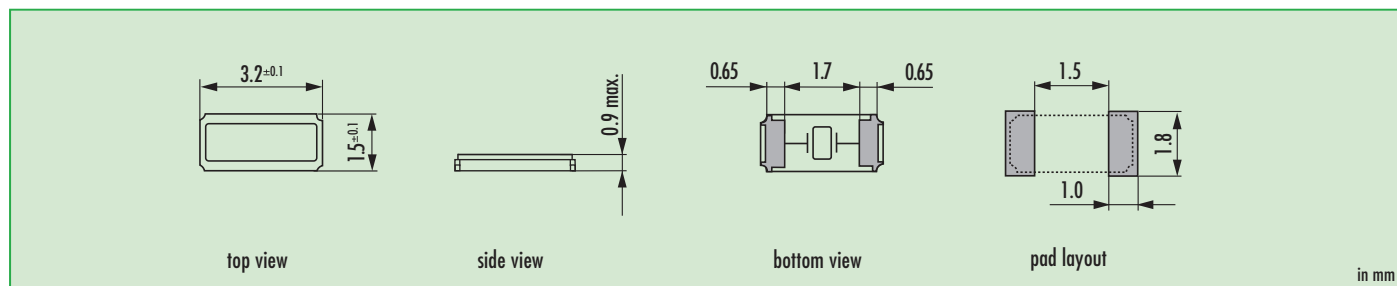

Order Information

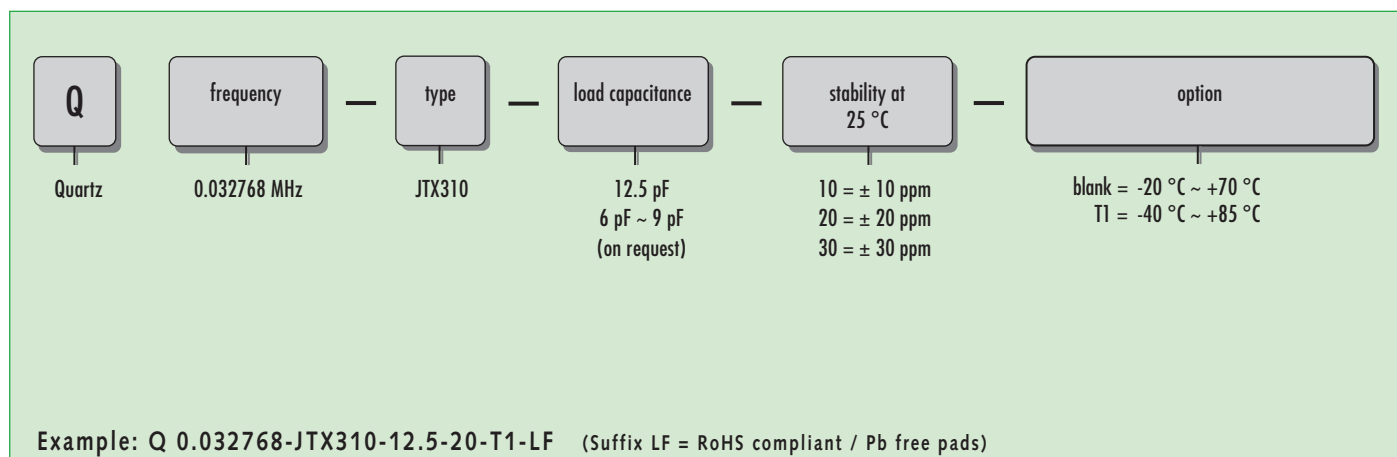

Quartz Crystal · JTX310

Taping Specification

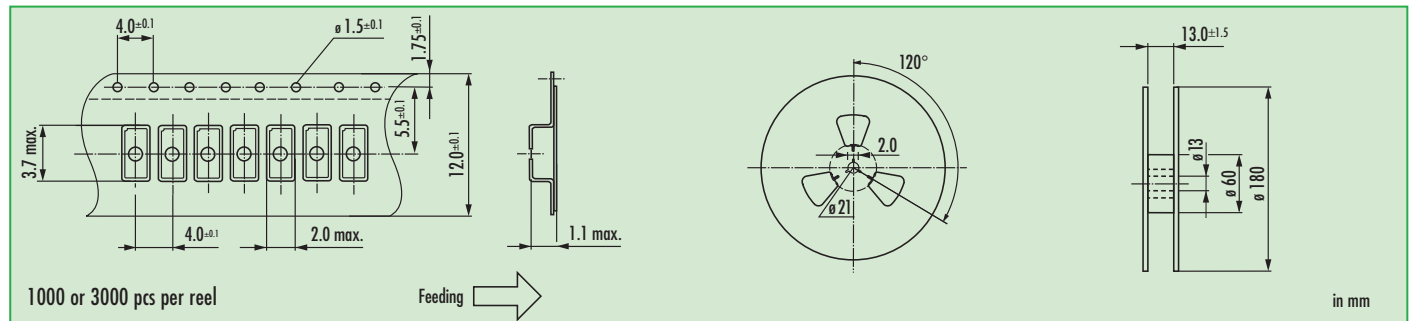

Reflow Soldering Profile

