

## MM54HC280/MM74HC280 9-Bit Odd/Even Parity Generator/Checker

### General Description

The MM54HC280/MM74HC280 utilizes advanced silicon-gate CMOS technology to achieve the high noise immunity and low power consumption of standard CMOS integrated circuits. It possesses the ability to drive 10 LS-TTL loads.

This parity generator/checker features odd/even outputs to facilitate operation of either odd or even parity applications. The word length capability is easily expanded by cascading devices. The 54HC/74HC logic family is speed, function, and pinout compatible with the standard 54LS/74LS family. All inputs are protected from damage due to static discharge by internal diode clamps to  $V_{CC}$  and ground.

### Features

- Typical propagation delay: 28 ns
- Wide power supply range: 2V–6V
- Low quiescent current: 80  $\mu$ A maximum (74HC)
- Low input current: 1  $\mu$ A maximum
- Fanout of 10 LS-TTL loads

### Connection Diagram

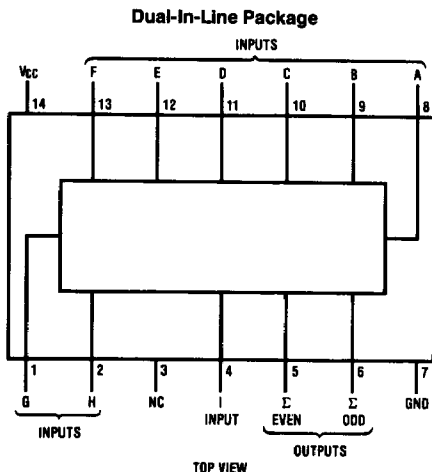

TL/F/5121-1

**Order Number MM54HC280\* or MM74HC280\***

\*Please look into Section 8, Appendix D for availability of various package types.

### Function Table

Numbers of Inputs A thru 1 that are High	Outputs	
	$\Sigma$ Even	$\Sigma$ Odd
0, 2, 4, 6, 8	H	L
1, 3, 5, 7, 9	L	H

H = high level, L = low level

**Absolute Maximum Ratings** (Notes 1 & 2)

If Military/Aerospace specified devices are required, contact the National Semiconductor Sales Office/Distributors for availability and specifications.

Supply Voltage ( $V_{CC}$ )	-0.5 to +7.0V
DC Input Voltage ( $V_{IN}$ )	-1.5 to $V_{CC}$ + 1.5V
DC Output Voltage ( $V_{OUT}$ )	-0.5 to $V_{CC}$ + 0.5V
Clamp Diode Current ( $I_{IK}, I_{OK}$ )	± 20 mA
DC Output Current, per pin ( $I_{OUT}$ )	± 25 mA
DC $V_{CC}$ or GND Current, per pin ( $I_{CC}$ )	± 50 mA
Storage Temperature Range ( $T_{STG}$ )	-65°C to +150°C
Power Dissipation ( $P_D$ )	
(Note 3)	600 mW
S.O. Package only	500 mW
Lead Temp. ( $T_L$ ) (Soldering 10 seconds)	260°C

**Operating Conditions**

	Min	Max	Units
Supply Voltage ( $V_{CC}$ )	2	6	V
DC Input or Output Voltage ( $V_{IN}, V_{OUT}$ )	0	$V_{CC}$	V
Operating Temp. Range ( $T_A$ )			
MM74HC	-40	+85	°C
MM54HC	-55	+125	°C
Input Rise or Fall Times ( $t_r, t_f$ )			
$V_{CC} = 2.0V$		1000	ns
$V_{CC} = 4.5V$		500	ns
$V_{CC} = 6.0V$		400	ns

**DC Electrical Characteristics** (Note 4)

Symbol	Parameter	Conditions	$V_{CC}$	$T_A = 25^\circ C$		74HC	54HC	Units
						$T_A = -40$ to $85^\circ C$	$T_A = -55$ to $125^\circ C$	
				Typ	Guaranteed Limits			
$V_{IH}$	Minimum High Level Input Voltage		2.0V		1.5	1.5	1.5	V
			4.5V		3.15	3.15	3.15	V
			6.0V		4.2	4.2	4.2	V
$V_{IL}$	Maximum Low Level Input Voltage**		2.0V		0.5	0.5	0.5	V
			4.5V		1.35	1.35	1.35	V
			6.0V		1.8	1.8	1.8	V
$V_{OH}$	Minimum High Level Output Voltage	$V_{IN} = V_{IH}$ or $V_{IL}$ $ I_{OUT}  \leq 20 \mu A$	2.0V	2.0	1.9		1.9	V
			4.5V	4.5	4.4		4.4	V
			6.0V	6.0	5.9		5.9	V
		$V_{IN} = V_{IH}$ or $V_{IL}$ $ I_{OUT}  \leq 4.0$ mA $ I_{OUT}  \leq 5.2$ mA	4.5V	4.2	3.98		3.7	V
			6.0V	5.7	5.48		5.2	V
$V_{OL}$	Maximum Low Level Output Voltage	$V_{IN} = V_{IH}$ or $V_{IL}$ $ I_{OUT}  \leq 20 \mu A$	2.0V	0	0.1		0.1	V
			4.5V	0	0.1		0.1	V
			6.0V	0	0.1		0.1	V
		$V_{IN} = V_{IH}$ or $V_{IL}$ $ I_{OUT}  \leq 4.0$ mA $ I_{OUT}  \leq 5.2$ mA	4.5V	0.2	0.26		0.4	V
			6.0V	0.2	0.26		0.4	V
$I_{IN}$	Maximum Input Current	$V_{IN} = V_{CC}$ or GND	6.0V		± 0.1	± 1.0	± 1.0	μA
$I_{CC}$	Maximum Quiescent Supply Current	$V_{IN} = V_{CC}$ or GND $I_{OUT} = 0 \mu A$	6.0V		8.0	80	160	μA

**Note 1:** Absolute Maximum Ratings are those values beyond which damage to the device may occur.

**Note 2:** Unless otherwise specified all voltages are referenced to ground.

**Note 3:** Power Dissipation temperature derating — plastic "N" package: -12 mW/°C from 65°C to 85°C; ceramic "J" package: -12 mW/°C from 100°C to 125°C.

**Note 4:** For a power supply of 5V ± 10% the worst case output voltages ( $V_{OH}$ , and  $V_{OL}$ ) occur for HC at 4.5V. Thus the 4.5V values should be used when designing with this supply. Worst case  $V_{IH}$  and  $V_{IL}$  occur at  $V_{CC} = 5.5V$  and 4.5V respectively. (The  $V_{IH}$  value at 5.5V is 3.85V.) The worst case leakage current ( $I_{IN}$ ,  $I_{CC}$ , and  $I_{OZ}$ ) occur for CMOS at the higher voltage and so the 6.0V values should be used.

\*\* $V_{IL}$  limits are currently tested at 20% of  $V_{CC}$ . The above  $V_{IL}$  specification (30% of  $V_{CC}$ ) will be implemented no later than Q1, CY'89.

**AC Electrical Characteristics**  $V_{CC}=5V, T_A=25^{\circ}C, C_L=15\text{ pF}, t_r=t_f=6\text{ ns}$

Symbol	Parameter	Conditions	Typ	Guaranteed Limit	Units
$t_{PHL}, t_{PLH}$	Maximum Propagation Delay, Data to $\Sigma$ Even		28	35	ns
$t_{PHL}, t_{PLH}$	Maximum Propagation Delay, Data to $\Sigma$ Odd		28	35	ns

**AC Electrical Characteristics**  $V_{CC}=2.0V\text{ to }6.0V, C_L=50\text{ pF}, t_r=t_f=6\text{ ns}$  (unless otherwise specified)

Symbol	Parameter	Conditions	$V_{CC}$	$T_A=25^{\circ}C$		74HC	54HC	Units
						$T_A=-40\text{ to }85^{\circ}C$	$T_A=-55\text{ to }125^{\circ}C$	
$t_{PHL}, t_{PLH}$	Maximum Propagation Delay, Data to $\Sigma$ Even		2.0V	103	205	258	305	ns
			4.5V	21	41	52	61	ns
			6.0V	17	35	44	52	ns
$t_{PHL}, t_{PLH}$	Maximum Propagation Delay, Data to $\Sigma$ Odd		2.0V	103	205	258	305	ns
			4.5V	21	41	52	61	ns
			6.0V	17	35	44	52	ns
$t_{TLH}, t_{THL}$	Maximum Output Rise and Fall Time		2.0V	30	75	95	110	ns
			4.5V	8	15	19	22	ns
			6.0V	7	13	16	19	ns
$C_{PD}$	Power Dissipation Capacitance (Note 5)			83				pF
$C_{IN}$	Maximum Input Capacitance			5	10	10	10	pF

**Note 5:**  $C_{PD}$  determines the no load dynamic power consumption,  $P_D = C_{PD} V_{CC}^2 f + I_{CC} V_{CC}$ , and the no load dynamic current consumption,  $I_S = C_{PD} V_{CC} f + I_{CC}$ .

**Logic Diagram**

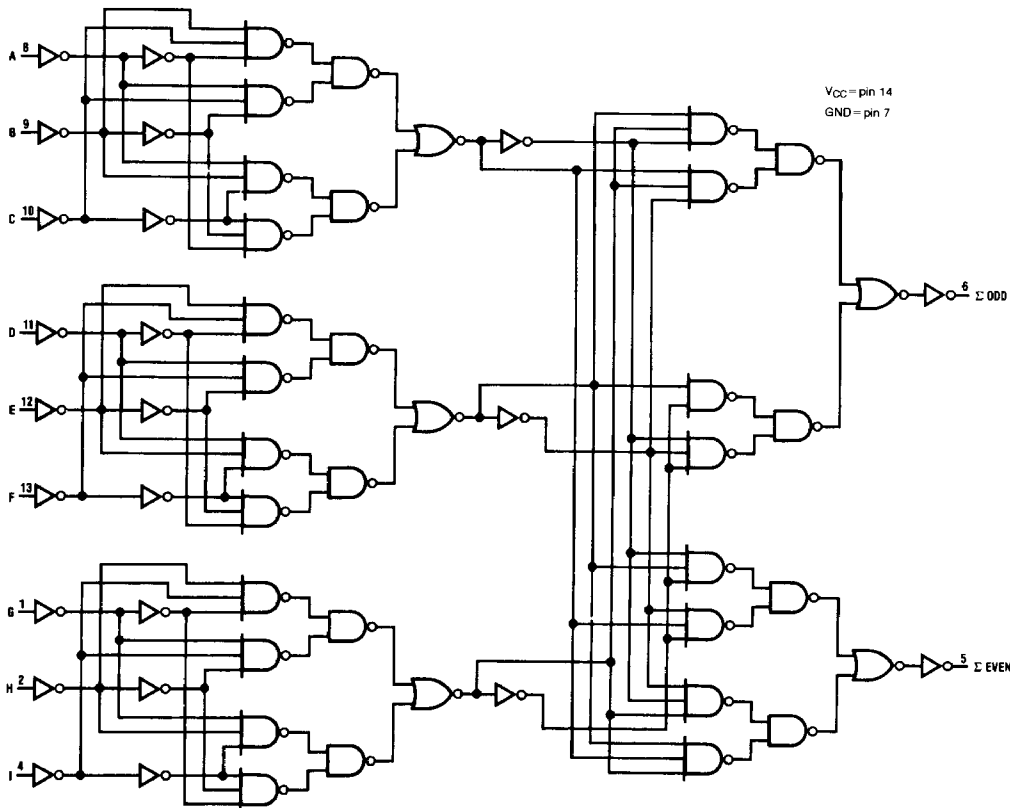

'HC280

TL/F/5121-2