

MITSUBISHI HIGH SPEED CMOS M74HC10P/FP/DP

TRIPLE 3-INPUT POSITIVE NAND GATE

DESCRIPTION

The M74HC10 is a semiconductor integrated circuit consisting of three 3-input positive-logic NAND gates, usable as negative-logic NOR gates.

FEATURES

- High-speed: 10ns typ. ($C_L=15\text{pF}$, $V_{CC}=5\text{V}$)
- Low power dissipation: $5\mu\text{W}/\text{package}$, max ($V_{CC}=5\text{V}$, $T_a=25^\circ\text{C}$, quiescent state)
- High noise margin: 30% of V_{CC} , min ($V_{CC}=4.5\text{V}$, 6V)
- Capable of driving 10 74LS TTL loads
- Wide operating voltage range: $V_{CC}=2\sim 6\text{V}$
- Wide operating temperature range: $T_a=-40\sim +85^\circ\text{C}$

APPLICATION

General purpose, for use in industrial and consumer digital equipment.

FUNCTIONAL DESCRIPTION

Use of silicon gate technology allows the M74HC10 to maintain the low power dissipation and high noise margin characteristics of the standard CMOS logic 4000B series while giving high-speed performance equivalent to the 74LS10.

Buffered outputs Y improve input-to-output transfer characteristics and reduce to a minimum output impedance variations with respect to input voltage variations.

When all inputs A, B and C are high, the output Y will become low, and when at least one of the inputs is low, the output Y will become high.

FUNCTION TABLE

Inputs		Output	
A	N	Y	
L	L	H	
H	L	H	
L	H	H	
H	H	L	

$$N = B \cdot C$$

ABSOLUTE MAXIMUM RATINGS ($T_a = -40\sim +85^\circ\text{C}$, unless otherwise noted)

Symbol	Parameter	Conditions	Ratings	Unit
V_{CC}	Supply voltage		$-0.5\sim +7.0$	V
V_I	Input voltage		$-0.5\sim V_{CC}+0.5$	V
V_O	Output voltage		$-0.5\sim V_{CC}+0.5$	V
I_{IK}	Input protection diode current	$V_I < 0\text{V}$ $V_I > V_{CC}$	-20 20	mA
I_{OK}	Output parasitic diode current	$V_O < 0\text{V}$ $V_O > V_{CC}$	-20 20	mA
I_O	Output current per output pin		± 25	mA
I_{CC}	Supply/GND current	V_{CC} , GND	± 50	mA
P_d	Power dissipation	{Note 1}	500	mW
T_{stg}	Storage temperature range		$-65\sim +150$	$^\circ\text{C}$

Note 1 : M74HC10FP, $T_a = -40\sim +60^\circ\text{C}$ and $T_a = 60\sim 85^\circ\text{C}$ are derated at $-6\text{mW}/^\circ\text{C}$.
M74HC10DP, $T_a = -40\sim +50^\circ\text{C}$ and $T_a = 50\sim 85^\circ\text{C}$ are derated at $-5\text{mW}/^\circ\text{C}$.

PIN CONFIGURATION (TOP VIEW)

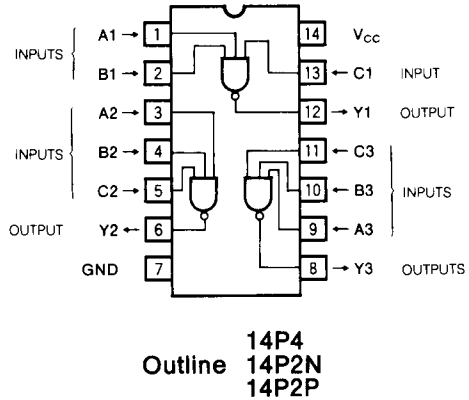

LOGIC DIAGRAM (EACH GATE)

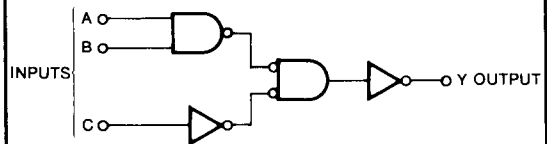

TRIPLE 3-INPUT POSITIVE NAND GATE

RECOMMENDED OPERATING CONDITIONS ($T_a = -40 \sim +85^\circ\text{C}$)

Symbol	Parameter	Limits			Unit
		Min	Typ	Max	
V_{CC}	Supply voltage	2		6	V
V_I	Input voltage	0		V_{CC}	V
V_O	Output voltage	0		V_{CC}	V
T_{opr}	Operating temperature range	-40		+85	$^\circ\text{C}$
t_r, t_f	Input risetime, falltime	$V_{CC} = 2.0\text{V}$	0	1000	ns
		$V_{CC} = 4.5\text{V}$	0	500	
		$V_{CC} = 6.0\text{V}$	0	400	

ELECTRICAL CHARACTERISTICS

Symbol	Parameter	Test conditions	Limits						Unit	
			$V_{CC}(\text{V})$	25 $^\circ\text{C}$			-40 \sim +85 $^\circ\text{C}$			
				Min	Typ	Max	Min	Max		
V_{IH}	High-level input voltage	$V_O = 0.1\text{V}, V_{CC} = 0.1\text{V}$ $ I_O = 20\mu\text{A}$	2.0	1.5			1.5		V	
			4.5	3.15			3.15			
			6.0	4.2			4.2			
V_{IL}	Low-level input voltage	$V_O = V_{CC} - 0.1\text{V}$ $ I_O = 20\mu\text{A}$	2.0			0.5		0.5	V	
			4.5			1.35		1.35		
			6.0			1.8		1.8		
V_{OH}	High-level output voltage	$V_I = V_{IH}, V_{IL}$	$I_{OH} = -20\mu\text{A}$	2.0	1.9			1.9	V	
			$I_{OH} = -20\mu\text{A}$	4.5	4.4			4.4		
			$I_{OH} = -20\mu\text{A}$	6.0	5.9			5.9		
			$I_{OH} = -4.0\text{mA}$	4.5	4.18			4.13		
			$I_{OH} = -5.2\text{mA}$	6.0	5.68			5.63		
V_{OL}	Low-level output voltage	$V_I = V_{IH}$	$I_{OL} = 20\mu\text{A}$	2.0			0.1		0.1	V
			$I_{OL} = 20\mu\text{A}$	4.5			0.1		0.1	
			$I_{OL} = 20\mu\text{A}$	6.0			0.1		0.1	
			$I_{OL} = 4.0\text{mA}$	4.5			0.26		0.33	
			$I_{OL} = 5.2\text{mA}$	6.0			0.26		0.33	
I_{IH}	High-level input current	$V_I = 6\text{V}$	6.0			0.1		1.0	μA	
I_{IL}	Low-level input current	$V_I = 0\text{V}$	6.0			-0.1		-1.0	μA	
I_{CC}	Quiescent supply current	$V_I = V_{CC}, \text{GND}, I_O = 0\mu\text{A}$	6.0			1.0		10.0	μA	

TRIPLE 3-INPUT POSITIVE NAND GATE

SWITCHING CHARACTERISTICS ($V_{CC} = 5V, T_a = 25^\circ C$)

Symbol	Parameter	Test conditions	Limits			Unit
			Min	Typ	Max	
t_{TLH}	Low-level to high-level and high-level to low-level output transition time	$C_L = 15pF$ (Note 3)			10	ns
t_{THL}					10	
t_{PLH}	Low-level to high-level and high-level to low-level output propagation time				15	ns
t_{PHL}					15	

SWITCHING CHARACTERISTICS ($V_{CC} = 2\sim 6V, T_a = -40\sim +85^\circ C$)

Symbol	Parameter	Test conditions	Limits						Unit
			25°C			-40~+85°C			
			$V_{CC}(V)$	Min	Typ	Max	Min	Max	
t_{TLH}	Low-level to high-level and high-level to low-level output transition time	$C_L = 50pF$ (Note 3)	2.0			75		95	ns
			4.5			15		19	
			6.0			13		16	
t_{THL}	output transition time		2.0			75		95	ns
			4.5			15		19	
			6.0			13		16	
t_{PLH}	Low-level to high-level and high-level to low-level output propagation time		2.0			95		120	ns
			4.5			19		24	
			6.0			16		20	
t_{PHL}	output propagation time	2.0			95		120	ns	
		4.5			19		24		
		6.0			16		20		
C_I	Input capacitance						10	pF	
C_{PD}	Power dissipation capacitance (Note 2)			36				pF	

Note 2 : C_{PD} is the internal capacitance of the IC per gate calculated from operation supply current under no-load conditions. (per gate)
The power dissipated during operation under no-load conditions is calculated using the following formula:
 $P_D = C_{PD} \cdot V_{CC}^2 \cdot f_i + I_{CC} \cdot V_{CC}$

Note 3 : Test Circuit

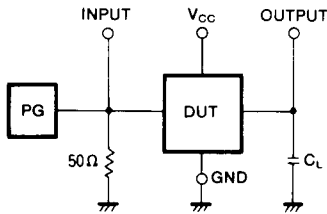

- (1) The pulse generator (PG) has the following characteristics (10%~90%): $t_r = 6ns, t_f = 6ns$
- (2) The capacitance C_L includes stray wiring capacitance and the probe input capacitance.

TIMING DIAGRAM

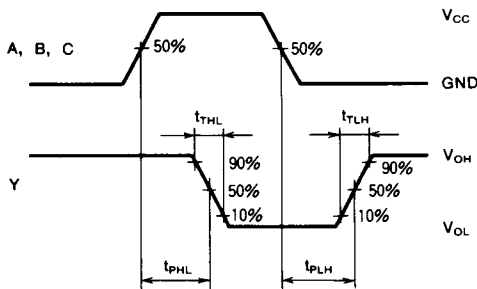

MITSUBISHI HIGH SPEED CMOS
PACKAGE OUTLINES

6249827 MITSUBISHI (DGTL LOGIC)

91D 12849

D T-90-20

TYPE 14P4 14-PIN MOLDED PLASTIC DIP

Dimension in mm

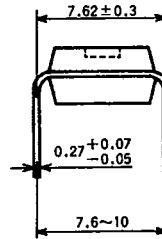
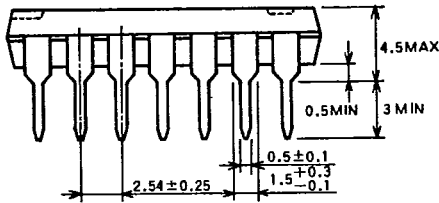
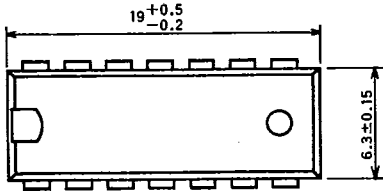

TYPE 16P4 16-PIN MOLDED PLASTIC DIP

Dimension in mm

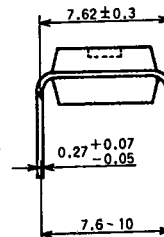
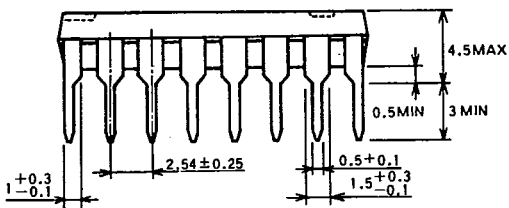
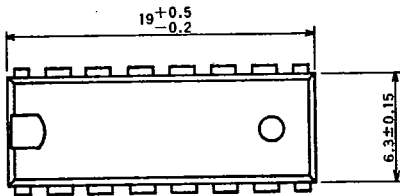

MITSUBISHI HIGH SPEED CMOS
PACKAGE OUTLINES

6249827 MITSUBISHI (DGTL LOGIC)

91D 12850 D.T-90-20

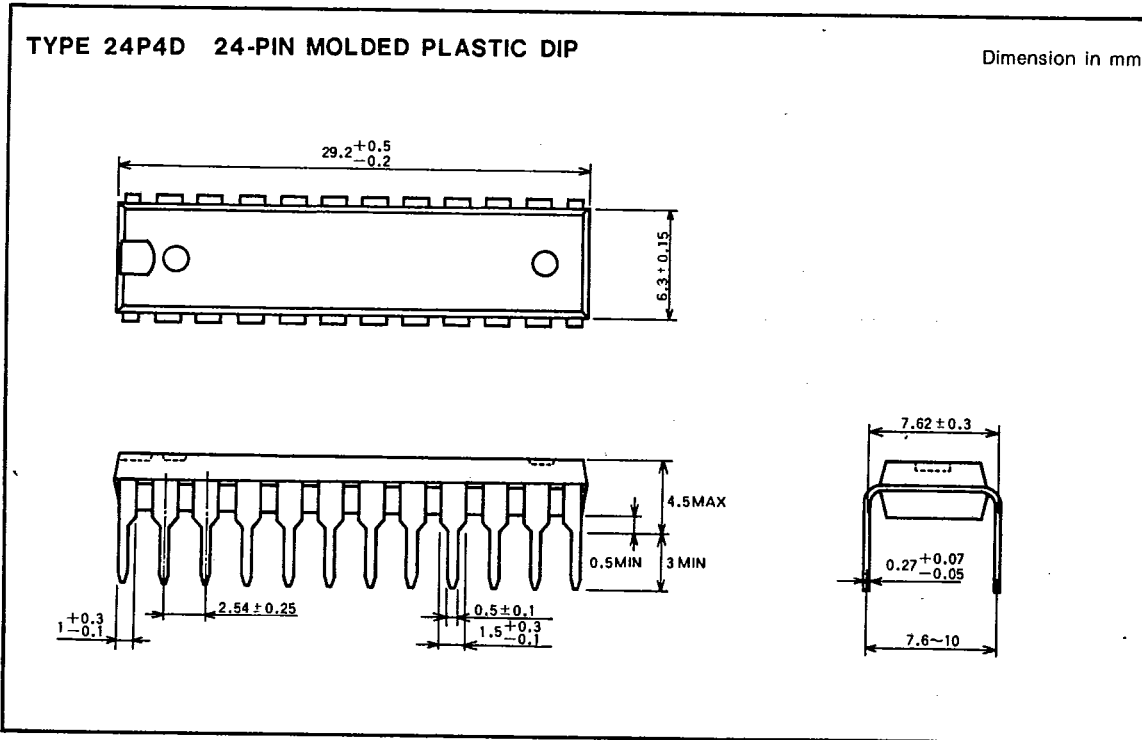
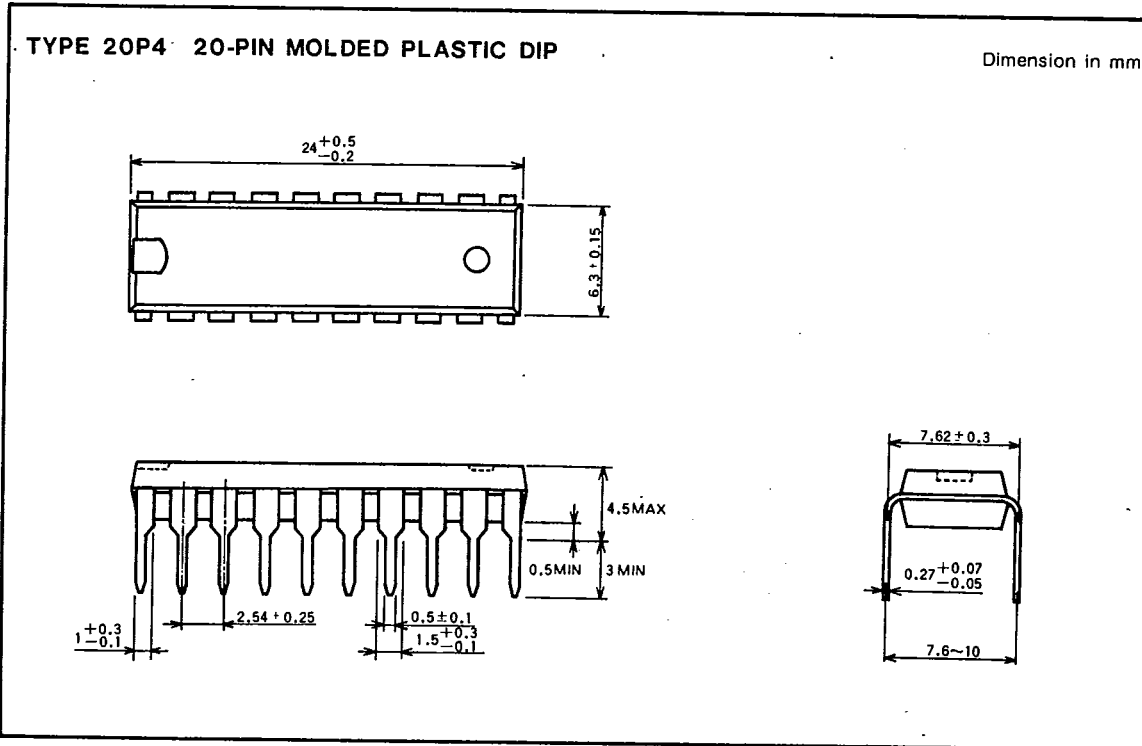

2933 G-02

MITSUBISHI ELECTRIC CO. TOKYO, JAPAN

MITSUBISHI HIGH SPEED CMOS
PACKAGE OUTLINES

6249827 MITSUBISHI (DGTL LOGIC)

91D 12851 D T-90.20

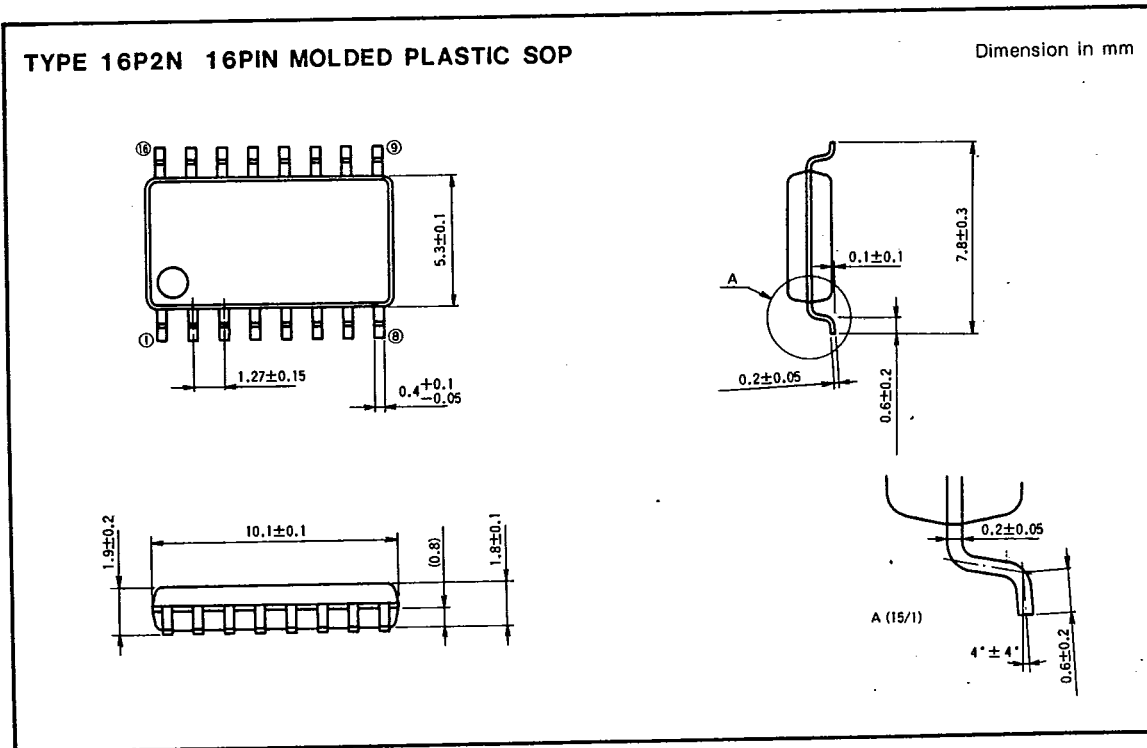
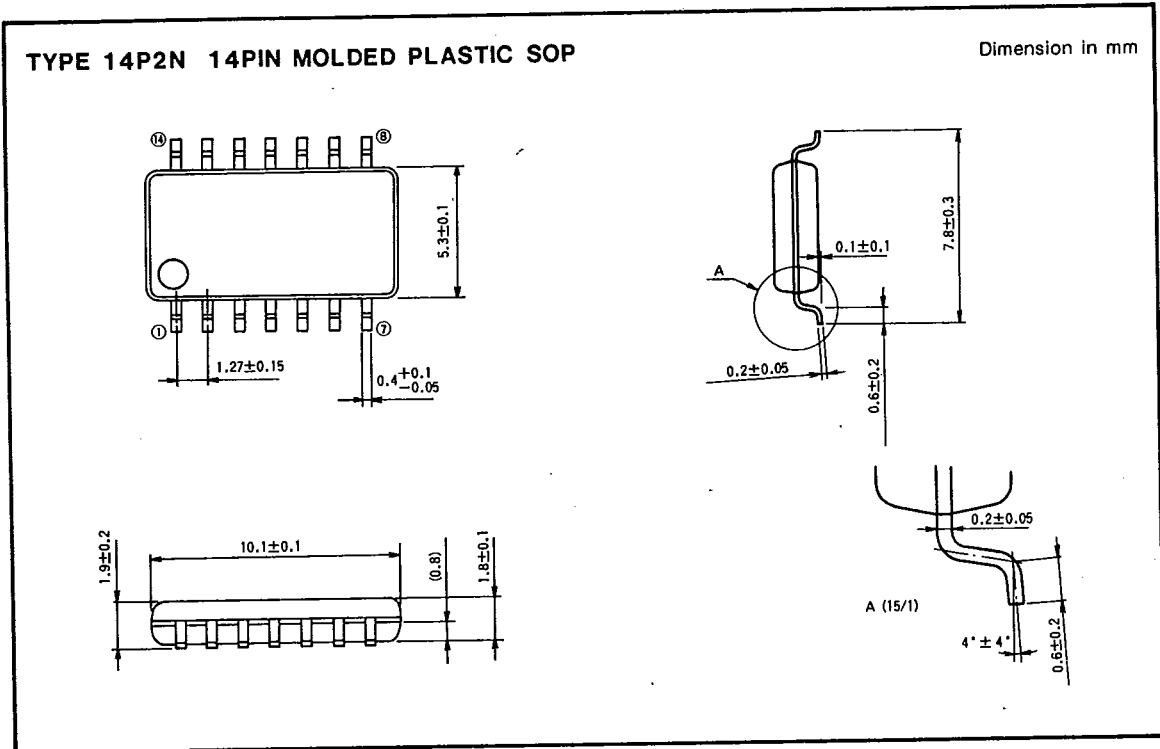

TYPE 20P2N 20PIN MOLDED PLASTIC SOP

Dimension in mm

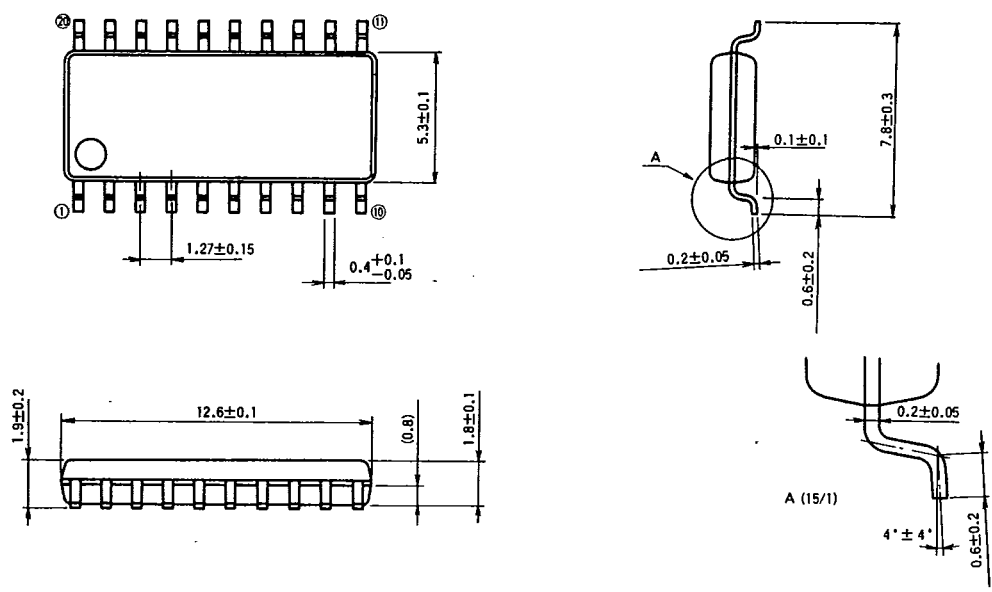

TYPE 24P2 24PIN MOLDED PLASTIC SOP

Dimension in mm

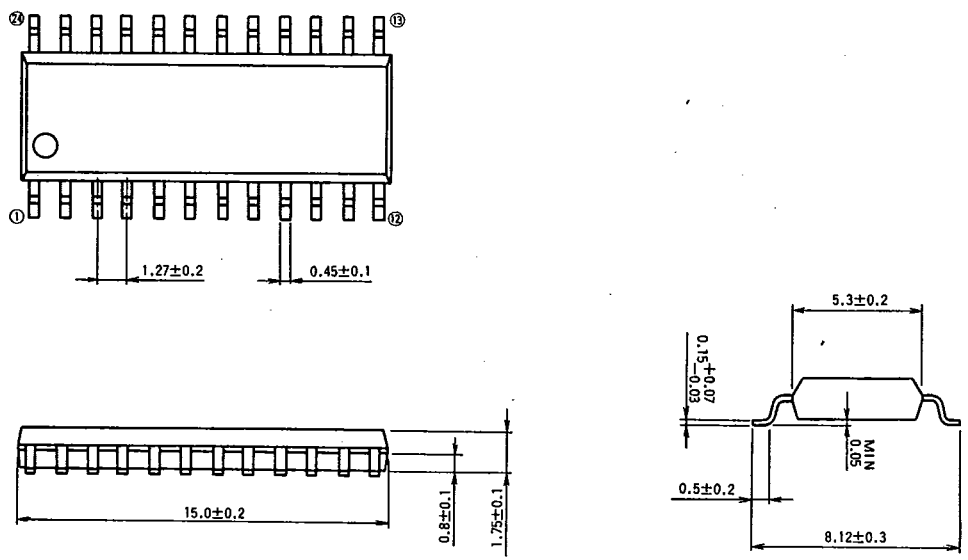

6249827 MITSUBISHI (DGTL LOGIC)

91D 12853 D T90-20

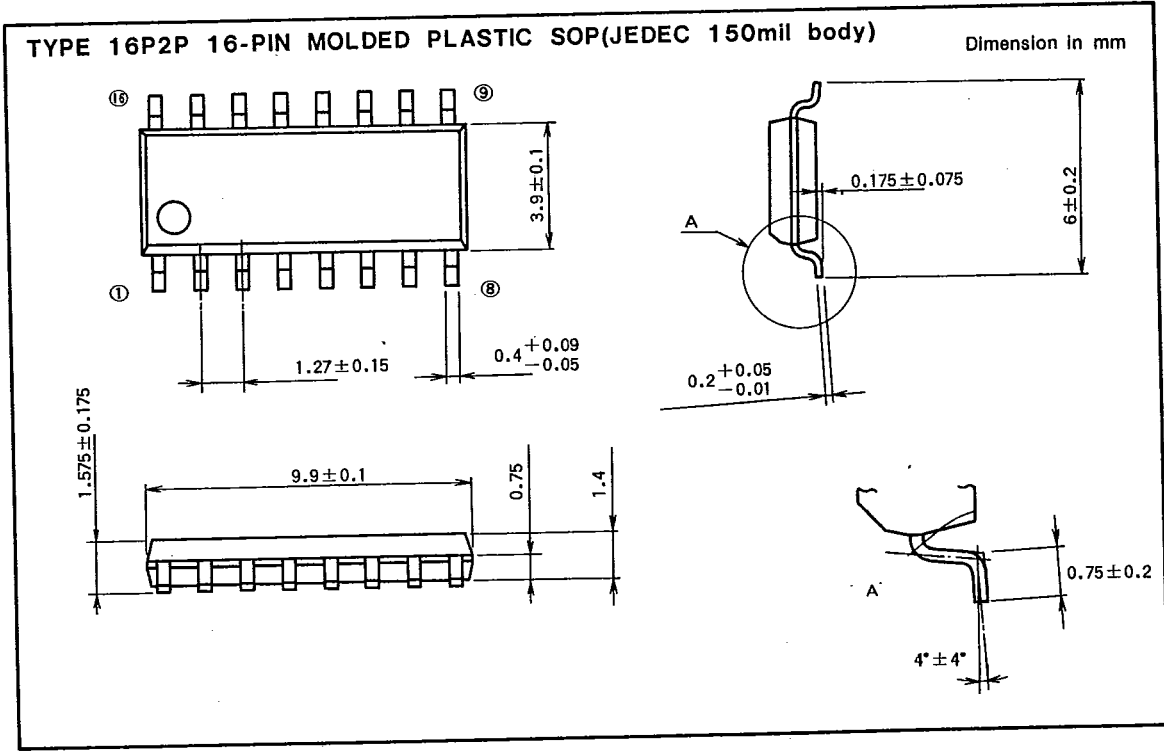
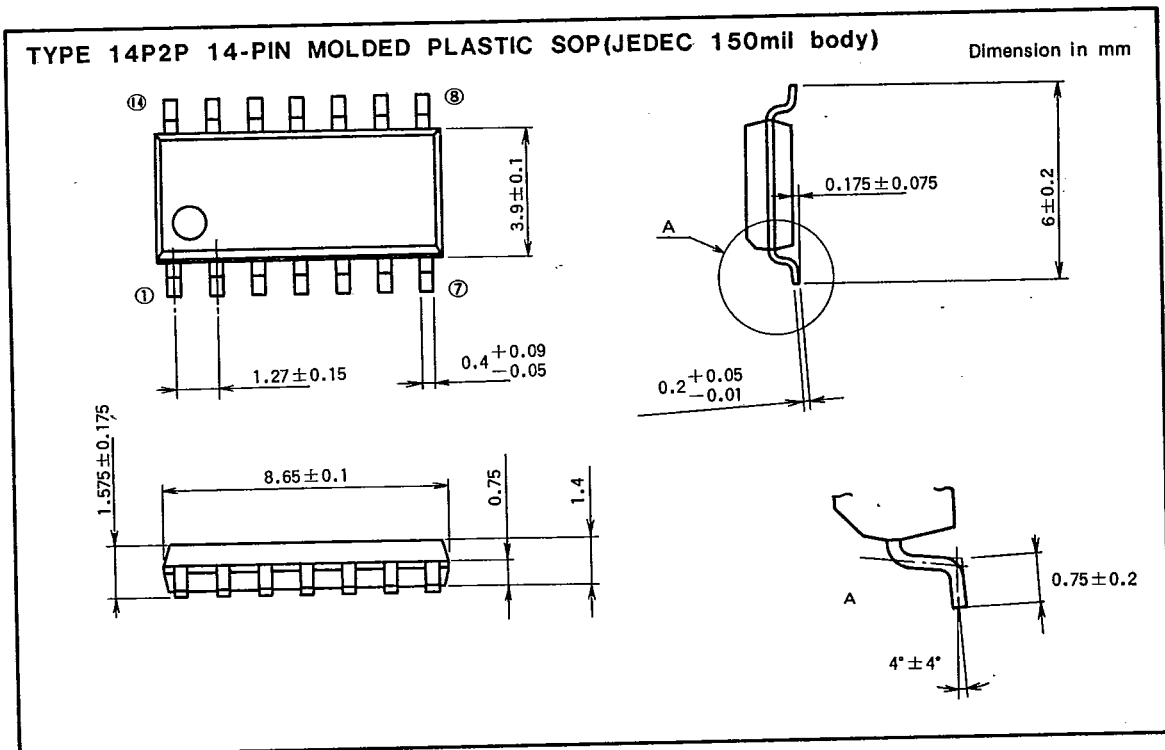

MITSUBISHI HIGH SPEED CMOS
PACKAGE OUTLINES

6249827 MITSUBISHI (DGTL LOGIC)

91D 12854 D T-90-20

