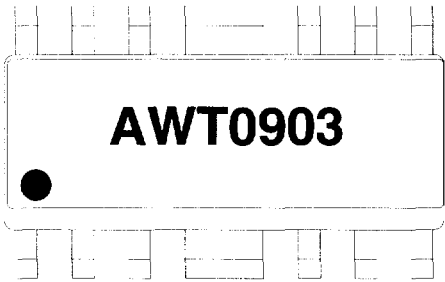

900 MHz Band ETACS GaAs Power Amplifier IC

<p>DESCRIPTION The AWT0903 is a monolithic Power Amplifier suited for ETACS cellular telephone applications.</p> <p>FEATURES:</p> <ul style="list-style-type: none"> High Output Power High Efficiency Low Distortion 16 Pin SOIC Plastic Package Surface Mount Package Low Cost 	 <p>The image shows a top-down view of the AWT0903 integrated circuit. It is a rectangular chip with a central label 'AWT0903' and a small circular mark on the left side. The chip is surrounded by a grid of 16 pins, with 8 pins on each long side.</p>
--	--

ABSOLUTE MAX. RATING

PIN	SIGNAL	MAX. RATING
1,3,14,16	$V_{REF}, V_{DS1}, V_{DS2}/RF_{OUT}, V_{DDC}$	$7.5 V_{DC}, 0 V_{DC}$
7	RF_{IN}	10 dBm
15	V_{SS}	$-3 V_{DC}$ to $-5 V_{DC}$

Operating Temperature: - 20° to 70°C
Storage Temperature: - 55° to 100° C

WIRELESS – Power Amplifier

AWT0903

ELECTRICAL CHARACTERISTICS: ⁽¹⁾

(Pin ≤ +8 dBm, f = 872 - 905 MHz, V_{DS1}=V_{DS2} = +5.8 V_{DC}, V_{REF} = +4.8 V_{DC}, V_{SS} = - 4V_{DC}, T_c = 25°C, 50Ω System.

PARAMETER	SYMBOL	MIN.	TYP.	MAX.	PARAMETER
Frequency	f _o	872		905	MHz
Power Output	P _{out}		30		dBm
Power Added Efficiency	PAE		52		%
Gain			23.5		dB
Harmonic ⁽²⁾	2nd 3rd 4th		- 33 - 38 - 40		dBc
Stability: - 80 dBc, ⁴ all spurious outputs relative to desired signal			7:1		VSWR load, all phase angles
Reference Voltage Supply Current	I _{REF}		3		mA
Negative Supply Current	I _{SS}		2		mA
Quiescent Current	I _{dsq1} + I _{dsq2}			150	mA
Input Return Loss ⁽¹⁾			15		dB
RX Noise ⁽³⁾			- 92		dBm

Notes:

- 1: As measured in ANADIGICS test fixture; see external circuit Page 5
- 2: Measured @ P_{out} = 30 dBm.
- 3: Noise in RX Frequency band @ bandwidth = 30 KHz
4. P_{out} = Rated P_{out}. V_{DS1} = V_{DS2} = + 5.8 V, Z_s = 50 Ω.

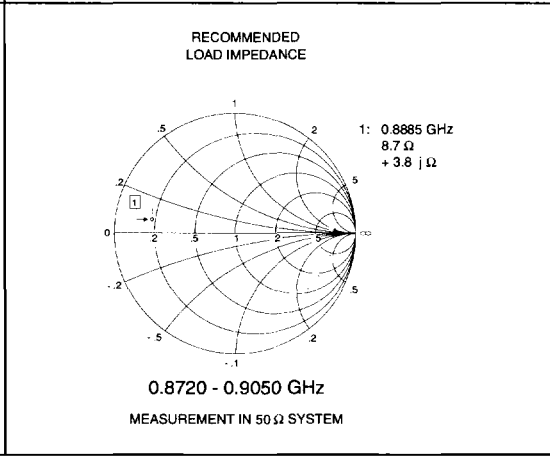
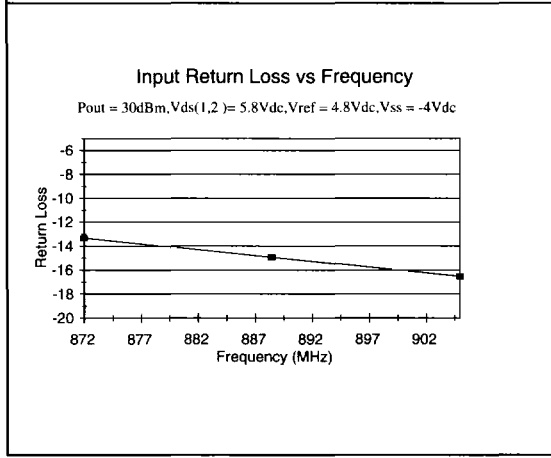
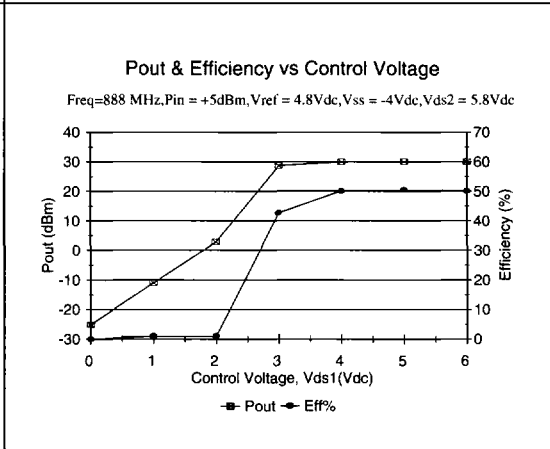
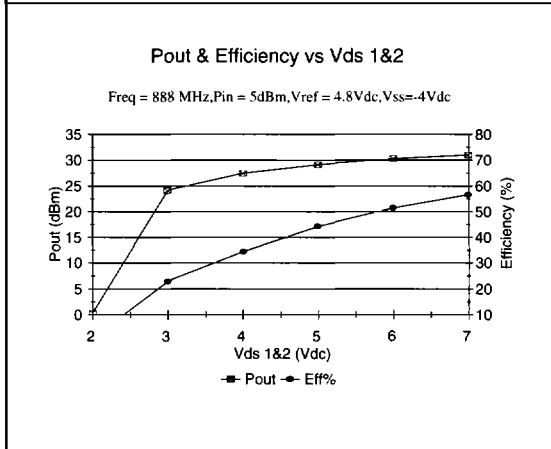
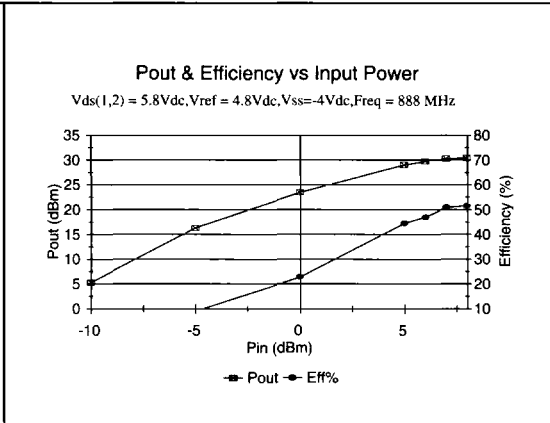
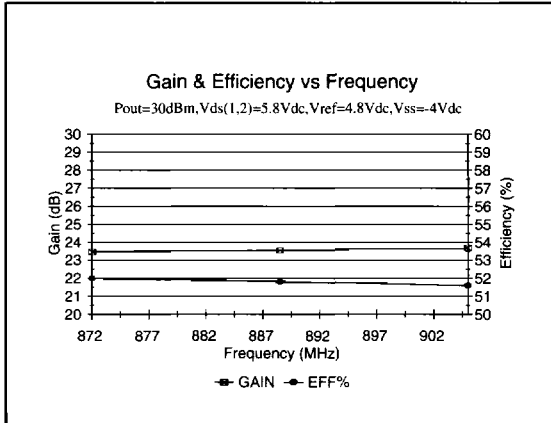

WIRELESS - Power Amplifier

AWT0903

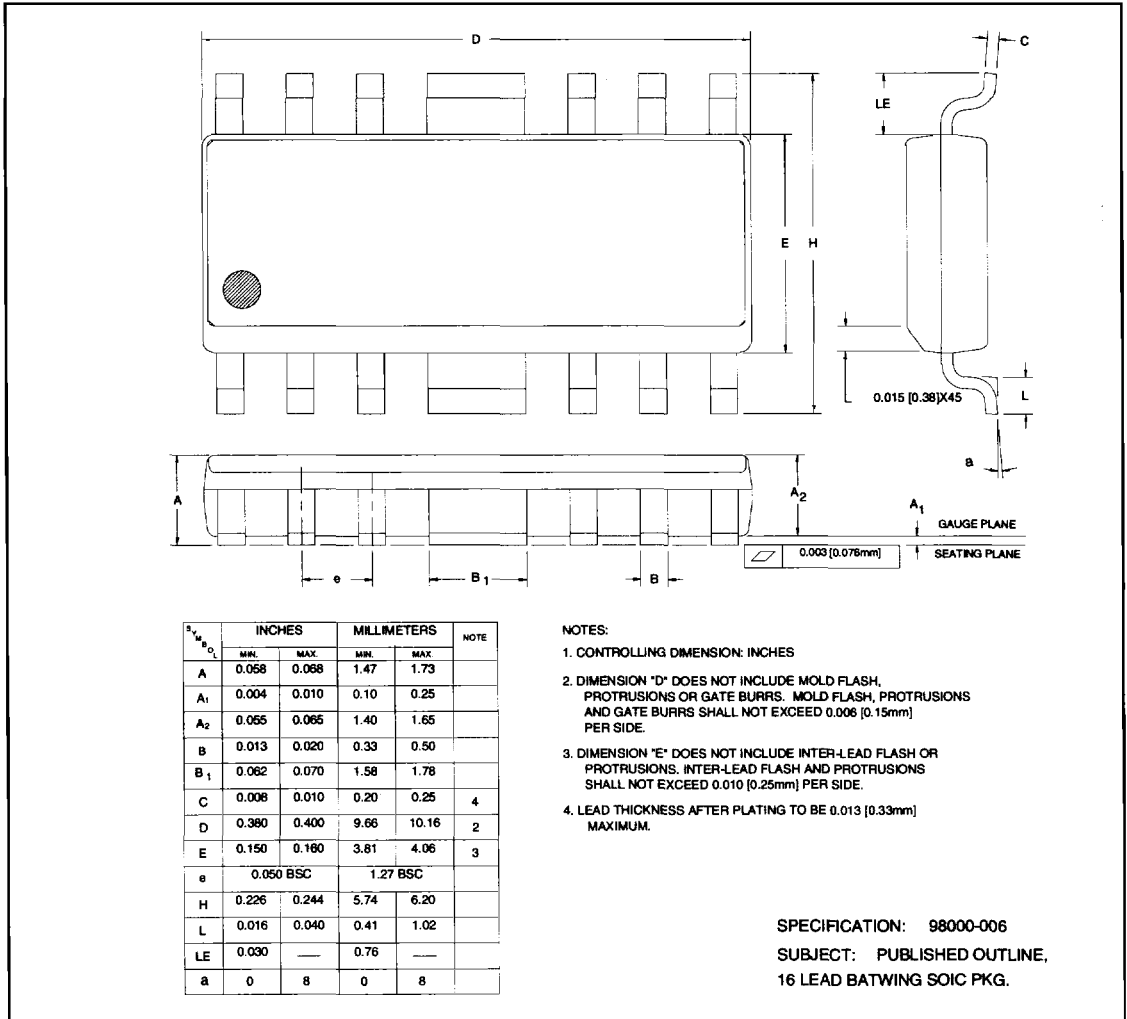

PIN	SIGNAL	DESCRIPTION
1	V_{REF}	Bias control for 1st and 2nd stage (+ 4.8V)
2	V_{GS2}	Gate of 2nd stage. Used to connect external de-coupling capacitor.
3	V_{DS1}	1st stage drain supply (+5.8V)
4:5	GND	AC & DC ground
6	V_{GS1}	Gate of 1st stage. Used to connect external bias network
7	RF_{IN}	RF Input
8 - 11	N/C	Not Connected
12 - 13	GND	AC & DC ground
14	V_{DS2}, RF_{OUT}	2nd stage drain supply (+ 5.8 V) RF output
15	V_{SS}	Negative supply bias network(- 4 V) (1st & 2nd stage)
16	V_{DDC}	Positive supply bias network (+ 5.8 V) (1st & 2nd Stage)

NOTE: Pin numbers 8 -11 are not connected internally but should be connected to the pc board ground for improved thermal conductivity.

OPERATIONAL PROCEDURE FOR POWER AMPLIFIER IC

CAUTION

SENSITIVE ELECTRONIC DEVICE, DO NOT OPERATE OR STORE NEAR STRONG ELECTROSTATIC FIELDS.

Device power up.

1. Apply - 4 V_{DC} to pin 15 (V_{SS}). " ALWAYS APPLY THIS VOLTAGE FIRST AND MAKE SURE IT IS THE LAST TO BE REMOVED" Applying positive voltage, V_{DS} , before - 4 V_{DC} (V_{SS}) will cause device damage.
2. Apply + 4.8 V_{DC} to pin 1 (V_{REF}).
3. Apply + 5.8 V_{DC} to pins 16, 14 and 3 (V_{DDC} , V_{DS2} , V_{DS1}).
4. Apply 0 dBm to RF input and increase input signal until required output level is reached.

"TO POWER DOWN THE DEVICE FOLLOW THE ABOVE PROCEDURE IN REVERSE ORDER."

WIRELESS – Power Amplifier

AWT0903

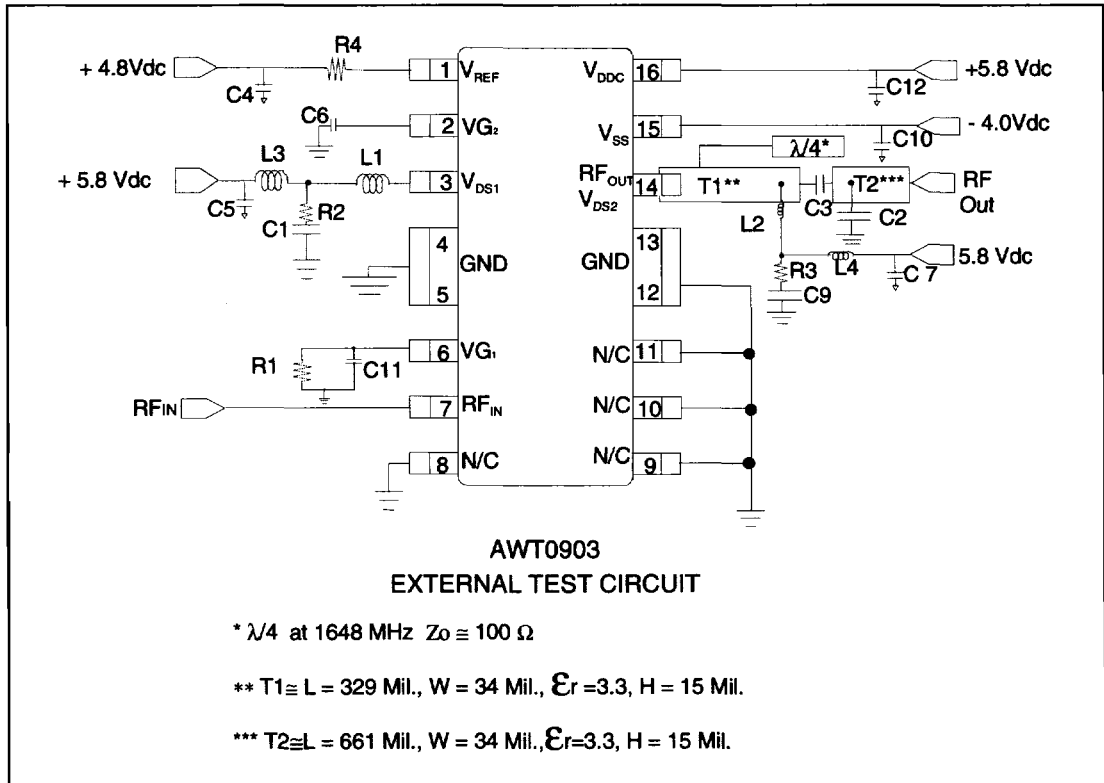

DESIGNATION	VALUE
R1	20 K Ω
R2,R3	20 Ω
R4	2 K Ω
C1,C6,C9,C11	47 η F
C8	6.8 pF
C2	4.7 pF
C3	220 Pf
C4,C5,C7,C10,C12	5 η F
L1,L2	56 η H
L3,L4	FERRITE Z = 600 @ 100 MHz