

Product Specifications



L2PDF-PMC

7-16 DIN Female Panel Mount for 3/8 in LDF2-50 cable



CHARACTERISTICS

General Specifications

Interface	7-16 DIN Female
Body Style	Panel mount
Mounting Angle	Straight

Electrical Specifications

Connector Impedance	50 ohm
Operating Frequency Band	0 – 6000 MHz
3rd Order IMD Test Method	Two +43 dBm Carriers
Average Power	0.7 kW @ 900 MHz
Cable Impedance	50 ohm
dc Test Voltage	2500 V
Inner Contact Resistance	1.50 mOhm
Insulation Resistance, minimum	10000 MOhm
Outer Contact Resistance	0.40 mOhm
Peak Power, maximum	15.60 kW
RF Operating Voltage, maximum (vrms)	894.00 V
Shielding Effectiveness	-110 dB
3rd Order IMD	-112 dBm @ 910 MHz

Product Specifications

Outline Drawing

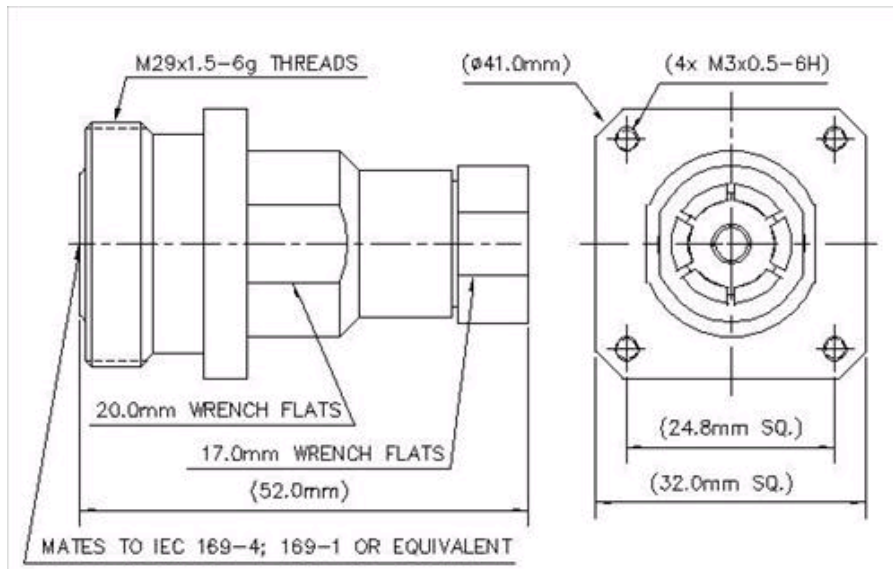

Mechanical Specifications

Outer Contact Attachment Method	Self-flare
Connector Retention Tensile Force	670 N 151 lbf
Connector Retention Torque	3 N-m 2 ft lb
Coupling Nut Proof Torque Method	IEC 169-16:9.3.11
Coupling Nut Retention Force	1000.00 N 224.81 lbf
Coupling Nut Retention Force Method	IEC 169-16:9.3.11
Inner Contact Attachment Method	Captivated
Insertion Force	889.64 N 200.00 lbf
Insertion Force Method	IEC 169-16:9.3.5
Interface Durability	500 cycles
Interface Durability Method	IEC 169-4:17
Pressurizable	No

Dimensions

Nominal Size	3/8 in
Height	32.00 mm 1.26 in
Length	52.00 mm 2.05 in
Weight	82.00 g 0.18 lb
Width	32.00 mm 1.26 in

Environmental Specifications

Corrosion Test Method	IEC 60068-2-11
Immersion Depth	1 m
Immersion Test Mating	Mated
Immersion Test Method	IEC 60529:2001, IP68
Mechanical Shock Test Method	IEC 60068-2-27

Product Specifications



Moisture Resistance Test Method	IEC 60068-2-3
Operating Temperature	-55 °C to +85 °C (-67 °F to +185 °F)
Storage Temperature	-65 °C to +125 °C (-85 °F to +257 °F)
Thermal Shock Test Method	IEC 60068-2-14
Vibration Test Method	IEC 60068-2-6

Standard Conditions

Attenuation, Ambient Temperature	20 °C 68 °F
Average Power, Ambient Temperature	40 °C 104 °F
Average Power, Inner Conductor Temperature	100 °C 212 °F

* Footnotes

Immersion Depth	Immersion at specified depth for 24 hours
-----------------	---