

PBL 3852

Universal Transmission Circuit

Description

The PBL 3852 is an universal transmission circuit in bipolar technology that performs all the speech and line interface functions required to implement an electronic telephone set suitable for the majority of existing telephone network requirements.

Easy adaptation of the DC-mask to different line feed systems. A summing point for auxiliary signals to be transmitted like DTMF and hands-free audio signal. The PBL 3852 has a low current consumption that enables the circuit to work with reduced performance down to 2.1 volts (4.8 mA) across the circuit. The low current consumption for a speech circuit is essential in telephone line powered handsfree designs required to work at long line lengths. The PBL 3852 is especially suitable to be used with Ericsson handsfree circuits like PBL 3786, PBL 3786/2, PBL 3881 and PBL 3880 thanks to a specific interfacing arrangement.

The transmitting and receiving gains can be regulated in order to compensate for the attenuation of the signals due to increasing attenuation with increasing line length. It is also possible to limit high transmitting signal levels (soft clipping) thus preventing excessive distortion caused by signal clipping. The gain regulation is set with discrete external components.

The circuit is easily adapted to different markets by setting the application dependent parameters individually in certain order, this preventing the interaction between the same. PBL 3852 has up to four different power supplies to feed microphones, auxiliary circuits and functions.

All pin numbers in this paper refer to DIP package.

Key Features

- Generates its own supply from the telephone line
- Adaptive to all types of telephone line feeding systems (i.e. 48V 2x200Ω, 60V 2x 600Ω, 48V 2x800Ω)
- Operates down to 2.1V (excl. polarity bridge)
- Adjustable DC-characteristic to the line
- Few inexpensive external components to function
- Easy adaptation for various market needs
- Dialler interface with DC-supply, mute, power-down and DTMF-input
- Confidence tone in the receiver at DTMF-dialling
- "Soft clipping" that prevents distortion at high transmit signal levels
- Balanced microphone input for dynamic, and electret microphones
- Balanced receiver output for dynamic and magnetic receiver elements
- Transmitter and receiver gain regulation for automatic loop loss compensation (disabled in mute mode)
- Four separate DC supplies for different requirements
- High gain of the receiver facilitates volume control function
- Microphone cut-off function possible by a switch
- All gain and frequency setting networks in Rx, Tx and side tone are referred to ground
- Excellent RFI performance

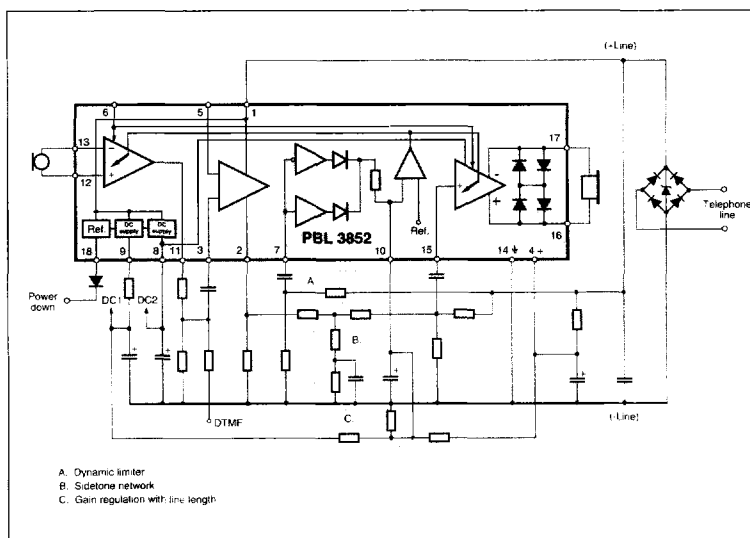
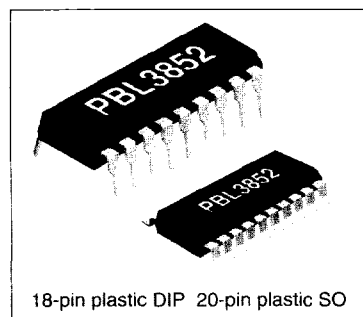

Figure 1. Functional diagram.



Maximum Ratings

Parameter	Symbol	Min	Max	Unit
Line voltage, $T_p = 2$ s	V_L	0	22	V
Line current, continuous DIP	I_L	0	130	mA
Line current, continuous SO package	I_L	0	100	mA
Operating temperature range	T_{Amb}	-40	+75	°C
Storage temperature range	T_{Stg}	-55	+125	°C
Input level (all inputs)		0	+C	V

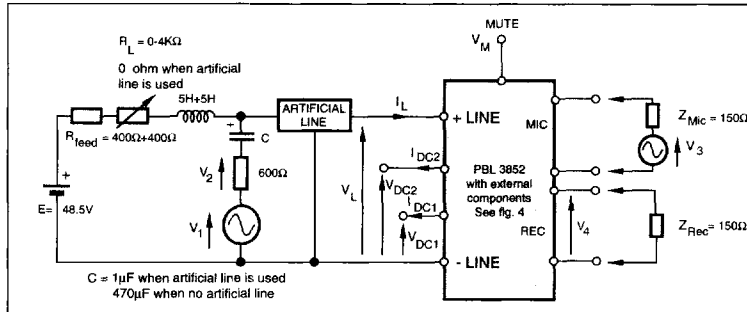

Figure 2. Test set up without rectifier bridge.

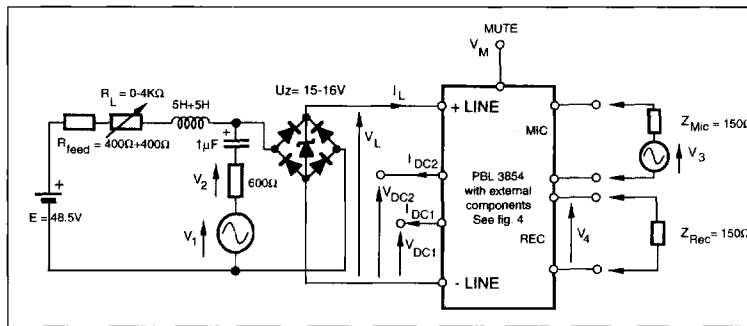

Figure 3. Test set up with rectifier bridge.

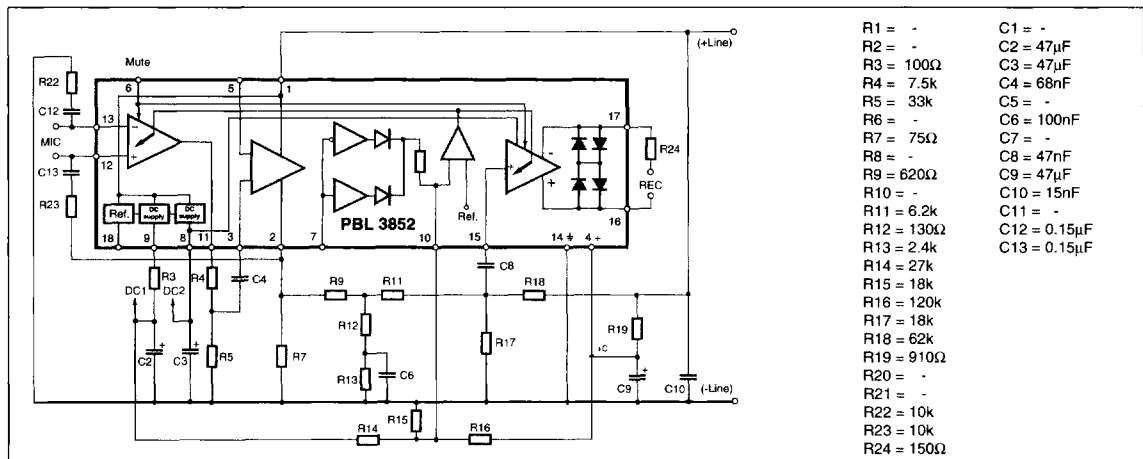

Figure 4. Reference figure with line length regulation. (Application for dynamic microphone)

Electrical Characteristics

At $T_{Amb} = +25^{\circ}C$. No cable and no line rectifier unless otherwise specified.

Parameter	Ref. fig.	Conditions	Min	Typ	Max	Unit
Line voltage, V_L note 1	2	$I_L = 15 \text{ mA}$	3.3	3.7	4.1	V
	2	$I_L = 100 \text{ mA}$	11	13	15	V
Transmitting gain, note 1		$20 \cdot^{10}\log (V_2 / V_3)$; 1 kHz				
	2	$R_L = 0$	41	43	45	dB
	2	$R_L = 400\Omega$	43.5	45.5	47.5	dB
	2	$R_L = 900\Omega - 2200\Omega$	46	48	50	dB
Transmitting range of regulation note 1	2	1 kHz, $R_L = 0$ to 900 ohm	3	5	7	dB
Transmitting frequency response	2	200 Hz to 3.4 kHz relative to 1 kHz	-1		1	dB
Receiving gain, note 1		$20 \cdot^{10}\log (V_4 / V_1)$; 1 kHz				
	2	$R_L = 0\Omega$	-13	-11	-9	dB
	2	$R_L = 400\Omega$	-10.5	-8.5	-6.5	dB
	2	$R_L = 900\Omega - 2200\Omega$	-8	-6	-4	dB
Receiving range of regulation	2	1 kHz, $R_L = 0$ to 900 Ω	3	5	7	dB
Receiving frequency response	2	200 Hz to 3.4 kHz relative to 1kHz	-1		1	dB
Microphone input impedance pin 12 (14),13 (15)	2	1 kHz,		1.7		k Ω
Transmitter input impedance pin 3	2	1 kHz		17		k Ω
Transmitter dynamic output	2	200 Hz - 3.4 kHz $\leq 2\%$ distortion, $I_L = 20 - 100 \text{ mA}$		1.5		V_p
Transmitter max. output	2	200 Hz - 3.4 kHz $I_L = 0 - 100 \text{ mA}$, $V_3 = 0 - 1 \text{ V}$		3		V_p
Receiver output impedance	2	1 kHz, $R_L = 0\Omega$, note 4		32(+150)		Ω
Receiver dynamic output	2	200 Hz - 3.4 kHz $\leq 2\%$ distortion, $I_L = 20 - 100 \text{ mA}$		0.5		V_p
Receiver max. output	3	Measured with line rectifier 200 Hz - 3.4 kHz, $I_L = 0 - 100 \text{ mA}$ $V_1 = 0 - 50 \text{ V}$		0.9		V_p
Transmitter output noise	2	Psoph-weighting, Rel 1 V_{rms} , $R_L = 0$		-75		dB $_{Psoph}$
Receiver output noise	2	A-weighting, Rel 1 V_{rms} , with cable 0 - 5 km, $\phi = 0.5 \text{ mm}$ note 3 0 - 3 km, $\phi = 0.4 \text{ mm}$		-80		dB $_A$
Mute input current	2		20			μA
DC1-supply voltage	2	$I_L = (20 - 100) \text{ mA}$ note 2 $I_{DC1} = 1 \text{ mA}$	1.75	2.0	2.25	V
DC2-supply voltage (clamp)	2	$I_L = 20-100 \text{ mA}$ see text, $I_{DC2} = 1.9 \text{ mA}$ note 2 at zero signal in the receiver amplifier	3.4	3.7	4.0	V

Notes

- Adjustable to both higher and lower values with external components.
- Lowest line current dependent of the set DC-characteristic. See page 14, fig 8.
- Psophometric weighting will give (6-7) dB lower value. (-dB)
- 150 ohm resistor in test set up.

Pin Description

DIP	SO	Symbol	Description
1	1	+L	Positive line terminal
2	2	TO	Slope setting for DC characteristic and sidetone balancing signal output
3	3	TI	Transmitter amplifier input
4	4	+C	Internal power supply
5	5	DCC	Line voltage DC level adjustment input
6	6	MUTE	Transmitter and receiver amplifier mute input
7	7	RCT	Dynamic limiter "soft clipping" input
8	8	DC2	DC supply 2 output, typically 3.7 V
9	9	DC1	DC supply 1 output, typically 2.1 V
	10	NC	Not connected
	11	NC	Not connected
10	12	GR	The output of the rectifier to the dynamic limiter and gain regulation input
11	13	MO	Microphone amplifier output
12	14	MI1	Microphone amplifier non-inverting input
13	15	MI2	Microphone amplifier inverting input
14	16	-L	Negative line terminal
15	17	RI	Receiver amplifier input
16	18	RO1	Receiver amplifier inverting output
17	19	RO2	Receiver amplifier non-inverting output
18	20	\overline{PD}	Power down input

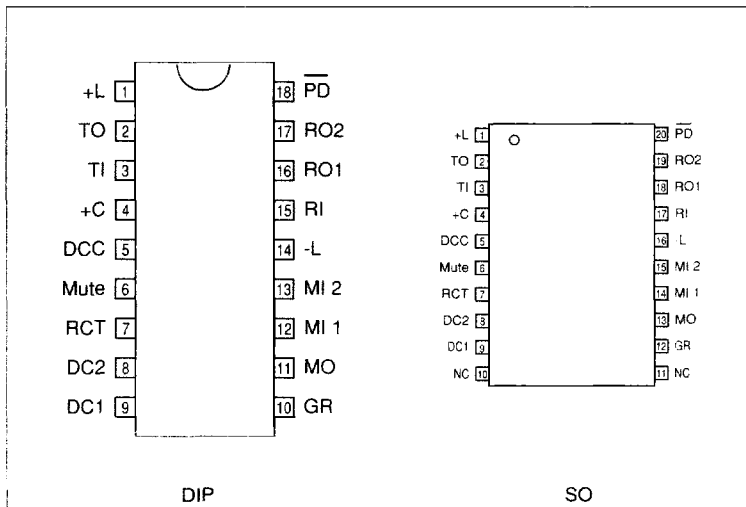

Figure 5. Pin configuration.

Functional Description

Design procedure

1. Set the circuit impedance to the line, either 600Ω or complex. (R19 and C9). C9 should be big enough to give low impedance compared with R19 in the telephone speech frequency band. Too large C9 will make the start-up slow.
2. Set the DC-characteristic that is required in the PTT specification or in case of a system telephone in the PBX specification (R7). There are also internal circuit dependent requirements like supply voltages etc.
3. Set the attac point where the line length regulation is supposed to cut in (R14,R15 and R16). Note that in some countries the line length regulation is not allowed. In most cases the end result is better and more readily achieved by using the line length regulation (line loss compensation) than without.
4. Set the transmitter gain, regulation and frequency response. See text for the dynamic limiting feature.
5. Set the receiver gain and frequency response. See text how to limit the max. swing to the earphone.
6. Adjust the side tone balancing network.
7. Set the RFI suppression components in case necessary. In two piece telephones the often "helically" wound cord acts as an aerial where especially the microphone input with its high gain and input impedance is the more sensitive.

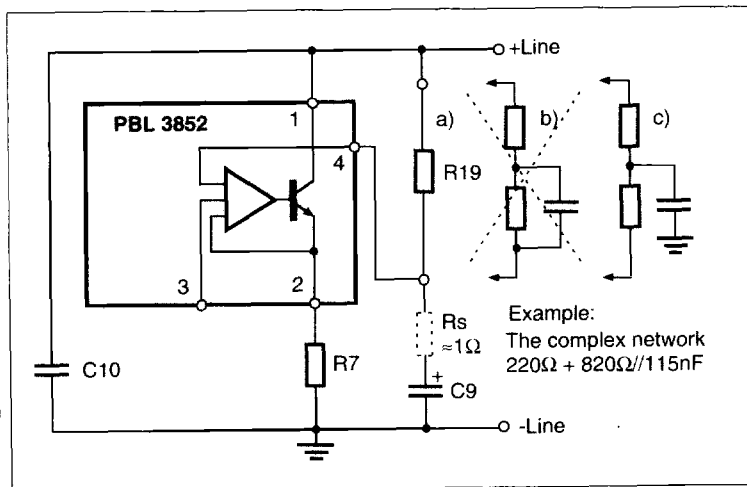

Figure 6. AC-impedance.

Impedance to the line

The AC- impedance to the line is set by C10, R19 and C9. Fig. 6. The circuits relatively high ($\approx 20k$ with $R7 = 75\Omega$) parallel impedance will influence it to some extent. At low frequencies the influence of the C9 can not be neglected. Series resistance of the C9 that is dependent on temperature and quality will cause that some of the line signal will enter pin 4 and generate a closed loop in the transmitter amplifier that will create an active impedance thus lowering the impedance to the line. The impedance at high frequencies is set by C10 that also acts as a RFI suppressor.

In many specifications the impedance towards the line is specified as a complex network. See fig. 6. In case a) the error

signal entering pin 4 is set by the ratio $\approx R_s/R_{19}$ (909Ω), where in case b) the ratio at high frequency will be $R_s/220\Omega$ because the 820Ω resistor is bypassed by a capacitor. To help up this situation the complex network capacitor is connected directly to ground, case c) making the ratio $R_s/220\Omega + 820\Omega$ and thus lessening the error signal. Conclusion: Use case c) when complex impedance is specified.

DC - characteristic

The DC - characteristic that a telephone set has to fulfill is mainly given by the network administrator. Following parameters are useful to know when the DC behaviour of the telephone is to be set:

- The voltage of the feeding system
- The line feeding resistance 2 x.... ohms
- The maximum current from the line at zero line length
- The min. current at which the telephone has to work (basic function)
- The lowest and highest voltage permissible across the telephone set.
- The highest voltage that the telephone may have at different line currents is normally set by the network owners specification. The lowest voltage for the telephone is normally set by the different voltages that are needed for the different parts of the telephone. For ex. for transmitter output amplifier, receiver output amplifier, dialler, speech switching and loudspeaker amplifier in a handsfree telephone etc.

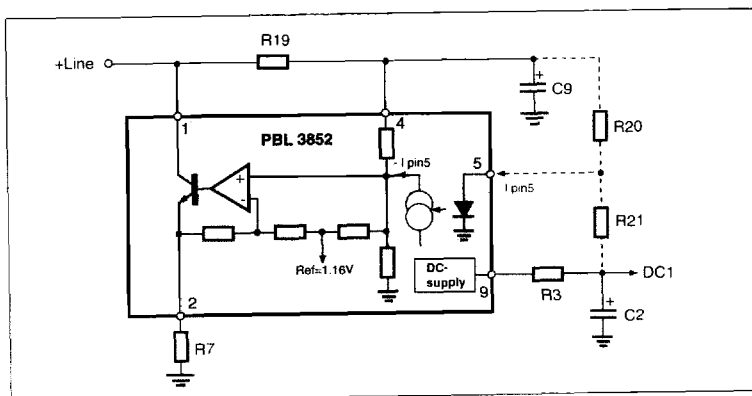

Figure 7. System of DC-Characteristic.

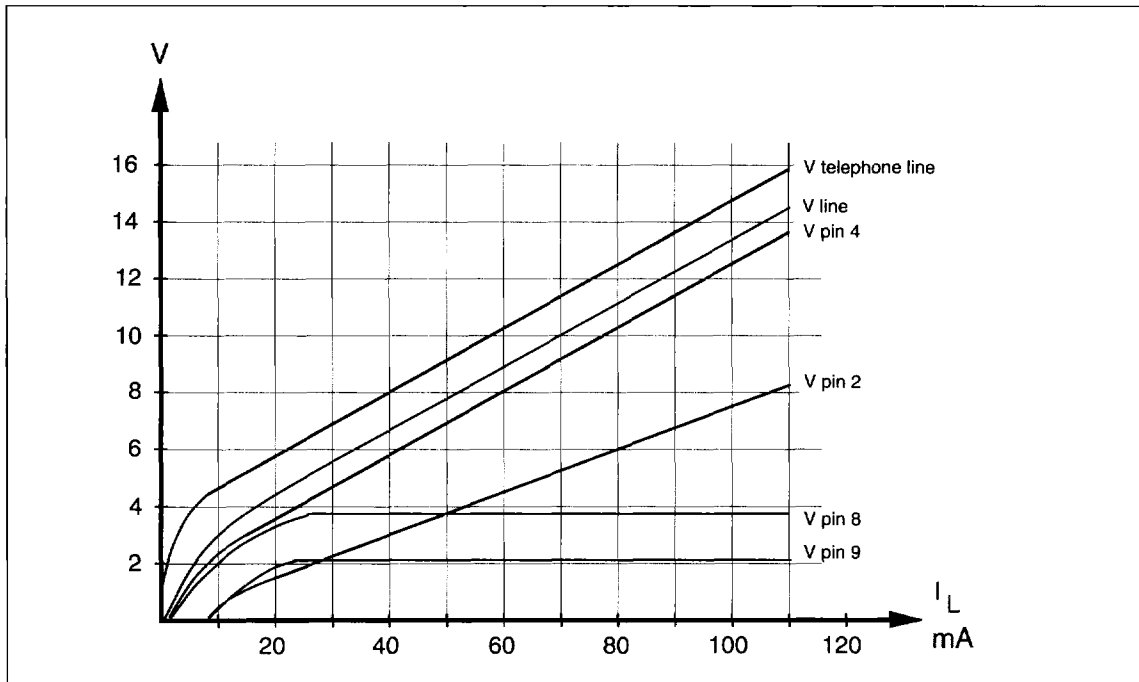

Figure 8. DC-Characteristics. ($R_7 = 75 \Omega$)

$$V_{\text{circ.}} = I_{\text{PIN4}} \cdot R_{19} + k_1 \cdot V_{\text{ref}} + R_7 \cdot I_{\text{line}} + k_2 \cdot V_{\text{pin2}} + a$$

$$a = I_{\text{pin5}} \cdot 5.5 \cdot 10^3 \text{ (if function DC - control at pin5 is used)}$$

$$k_1 \cdot V_{\text{ref}} = 1.1V$$

$$k_2 \cdot V_{\text{pin2}} = 0.5 \cdot R_7 \cdot I_{\text{line}}$$

$$I_{\text{PIN4}} = 1mA$$

The R_7 will set the slope of the DC-char. and the rest of the level is set by some constants in the circuits as shown in the equation. The slope of the DC-char. will also influence the line length regulation (when used) and thus the gain of both transmitter and receiver. R_7 acts also as current protection for the circuit, must be considered when low values are to be used. The level of DC-characteristic can be **adjusted** up at input pin 5 (some 100mV's). The R_{21} adjusts a fix amount where R_{20} couples the adjusted value to line current. See fig. 32.

Microphone amplifier

The microphone amplifier in the PBL 3852 is divided into two stages. The first stage is a true differential amplifier providing high CMRR (-55 to -65 dB

typical) with voltage gain of 19 dB. This stage is followed by a gain regulated amplifier with a regulation range from 6.5 dB to 14.5 dB, see fig. 15. The input of the microphone amplifier can be used for electret, magnetic or dynamic transducers see fig. 9. The PBL 3852 has basically a higher gain regulation range (8 dB) than the more or less standard 6 dB's for gain regulation with line length, this in order to be able to be used in applications where "softclipping" is required. In case lower regulation range is necessary, it is possible with some additional components.

See reference figs. 4, 10c, 10f, 32 and 33. For an electret microphone the circuitry will be simple, see fig. 10f. A resistor is added from the microphone amplifier output, pin 11, to the positive termination of the microphone and further

via a capacitor to the - input at pin 13. The DC supply resistors for the microphone should be round 200 Ω (in order not to overdrive the microphone amplifier) and the feedback resistor (17k) is of that magnitude that it either influences the CMRR balance at the input or destroys the send mute by bypassing signal round the microphone amplifier in mute state. For a dynamic microphone some more components are necessary, see fig. 10c. In order not to influence the send mute the feedback signal is taken from transmitter output at pin 2 and because this signal is in opposite phase with the signal at pin 11, it is taken to the other input at pin 12. Also in order not to influence the DC-balance of the microphone amplifier a capacitor has to be included in the feedback path and to maintain the CMRR of the

microphone amplifier a similar RC combination ought to be connected from the other input, pin 13, to ground.

An electret microphone with a built in FET amplifier is to be seen from outside as a high impedance constant current generator and is normally specified with a load resistance of $\approx 2k$. This is to be considered as max. value and by using it will render the max. gain from the microphone. This level of input signal that is unnecessary high will result in clipping in the microphone amplifier and in mute condition permeate through the input to the circuits reference and this way to all

functions, resulting among other things in a bad mute. Hence it is better regarding noise performance and mute to rather use the gain of the microphone amplifier than the gain of the microphone itself (in case of electret) flat out. A more suitable level of gain from the microphone is achieved by using a load resistance of 200 - 470 Ω . Gain setting to the line is done at the input of the transmitter.

It is possible to use the microphone amplifier as a limiter (added to the limiter in the transmitter output stage) of the transmitted signal (See fig. 9). The positive output swing is then limited by the

peak output current of the microphone amplifier. The negative swing is limited by the saturation voltage of the output amplifier. The output of the amplifier is DC-vice at internal reference level (1.16V). The lowest negative level for the signal is reference minus one diode and sat. transistor drop ($1.16-0.6-0.1 = 0.46V$). The correct clipping level is found by determining the composite AC- and DC-load that gives a maximum symmetrical unclipped signal at the output. This signal is then fed into the transmitter amplifier at a level that renders a symmetrical signal clipping on the line. (adjust with ratio R4, R5) The total transmitter gain when an electret microphone is used can then be adjusted with the load resistor of the electret microphones buffer amplifier.

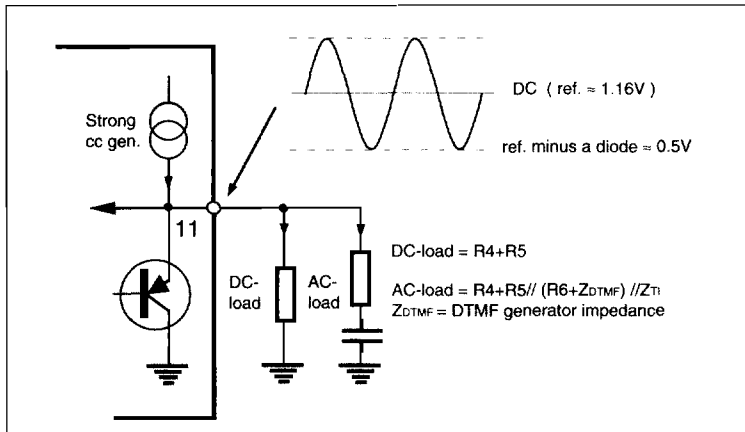

Figure 9. Microphone amplifier output clipping.

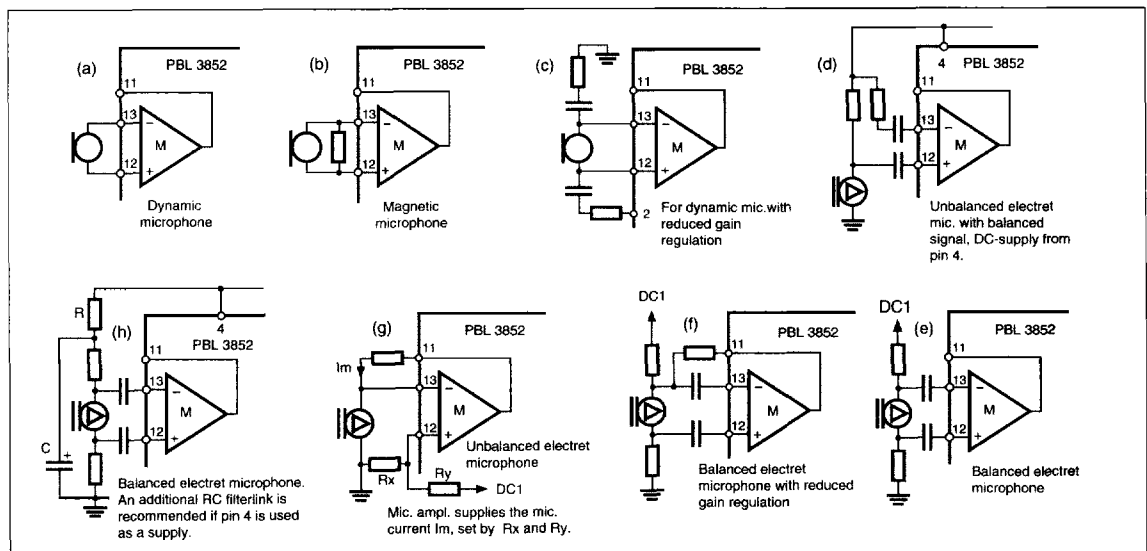

Figure 10. Microphone solutions.

Transmitter amplifier

The transmitter amplifier in PBL 3852 consists of three stages. The first stage is an amplitude limiter for the input signal at T1, in order to prevent the transmitted signal to exceed a certain set level and cause distortion. The second stage amplifies further the signal from the first and adds it to a DC level from an internal DC-regulation loop in order to give the required DC characteristic to the telephone set. The output for this stage is TO. The third stage is a current generator that presents a high impedance towards the line and has its gain from TO to +L. The gain of this amplifier is $ZL/R7$ where ZL is the impedance across the telephone line. Hence, the absolute maxi-

mum signal amplitude that can be transmitted to the line undistorted is dependent of R7.(amplitude limiting) The figure 20 shows the range for the amplitude limiter dependent of the operating point on the DC characteristic.

The transmitter gain and frequency response are set by the RC-network between the pins MO and T1 (See fig. 11). The capacitor for cutting the high frequency end is best to be placed directly at the microphone where it will also act as a RFI suppressor. The input signal source impedance to the transmitter amplifier input T1 should be reasonably low in order to keep the gain spread down, saying that $R4/R5/R6$ (see fig. 32) must be at least a factor of 5 lower than the Z_{Tin} . Observe that the capacitor C9 should have a

reasonably good temperature behaviour in order to keep the impedance rather constant. The V+C's influence on the transmitter DC-characteristic is shown in the fig. 8 therefore the transmitter gain would change if the transmitted signal gives reason to an ac-voltage leak signal across C9, this being a feedback point. If the transmitter has an unacceptable low swing to the line at low line currents $\leq 10mA$ the first should be to examine if the circuits DC-characteristic can be adjusted upwards and first secondly make use of the linear PD.

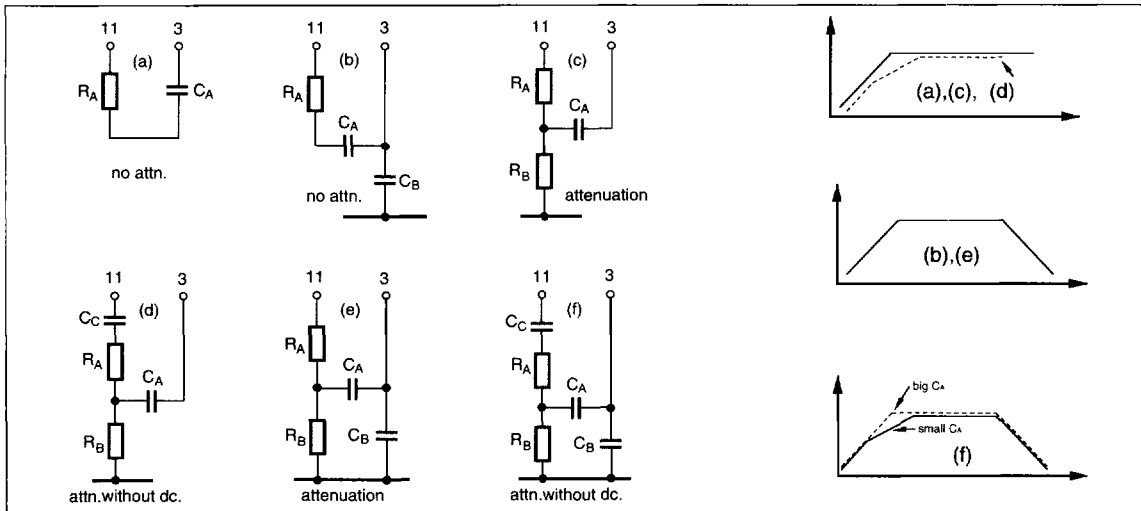

Figure 11. Different possible types of networks between microphone amplifier and transmitter.

Receiver amplifier

The receiver amplifier consists of three stages, the first stage being an input buffer that renders the input a high impedance. The second stage is a gain

regulated differential amplifier and the third stage a balanced power amplifier. The power amplifier has a differential output that does not need a series capacitor with the load. The receiver

amplifier uses at max. swing (4-6) mA peak. This current is drawn from DC2 that can supply 2 mA continuous current, the C3 helping to supply the peaks, this applies for speech signals only. Continuous sinusoidal signals at this level will load the DC2 down. If a distortion appears in the earphone amplifier output at high signal levels, high line currents, low ohmic earphone load or at low frequencies, the most probable fault is that the filtering capacitor of the earphone amplifier supply C3 is too small. At low line currents (normal case, $I_L < 10 mA$)

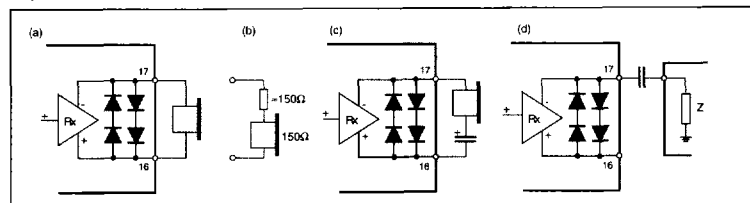

Figure 12. Receiver arrangements.

when the current and the voltage are not enough for full signal swing in the receiver amplifier, a sort of "soft clipping" is activated and lowers the gain so that no distortion will appear. A capacitor is needed at the output with low ohmic DC loads (some of the earphones have extremely low DC resistance) because even a small DC offset at the output will cause a great current drain from DC2 continuously. This capacitor is also needed if DC2 is used as a back up supply for some memories and the isolation is not done with a diode. The gain and frequency response is set at the input RI with a RC-network. The receiver gain can be regulated. The range of regulation from the input to the output is 5.8 dB (23.7 to 29.5dB). As

mentioned before the output amplitude can be limited by a resistor in series with the pin 8. An other method is to connect a series resistor with the earphone itself. In case of no signal at the input of the receiver, very little current is drawn from DC2. The same is valid at mute condition, understood that no DC current is drawn to somewhere else, as for example to a low ohmic DC load at earphone amplifier output. The receiver, contrary to most of our previous speech circuit families, can be loaded single ended resulting an undistorted signal. The load should be 10x the standard (150Ω) load of the amplifier with a capacitor in series, without a capacitor somewhat higher, depending on the required signal swing. The receiver has, as a principal

protection, two series diodes anti parallel across its output to limit the signal to the earphone and thus preventing an acoustical shock. A resistor in series with the output can very well be used to increase the protection level. Note, that the noise in the receiver is allways transmitter noise that has been more or less well balanced out in the side tone network.

Figure 12 b) shows a 150Ω resistor in series with a 150Ω earphone load. This is to minimize distortion and to decrease the DC-load rather than using a capacitor but it will give less swing with low line currents, $I_L < 15\text{mA}$.

Line length regulation

Line length regulation is used to compensate the gain loss in both transmitter and receiver due to increasing attenuation at increasing line length.

Setting the parameters for line length regulation (See fig.13)

The dotted line from dB axis to km axis indicates the attenuation versus line length that originates from the impedance in the increasing length of the specific cable used. It is generally desired that there is a gain regulation that compensates for this attenuation. The regulation should operate across a line length that comprises most of the subscribers. This will give the value for the line length P and is in most cases given by the network owner in their specification about the telephones acoustical behaviour. The amount of regulation is given by the portion of attenuation q. The slope of attenuation change within this area is given by q/P

(dB/km). The approximate centre point of the gain regulated line length portion is P/2. The line length above point P is not regulated in any sense and therefore follows the attenuation due to the increase in impedance at increasing line length.

To set the gain regulation:

- 1). Determine from the acoustics spec. diagram, that is given by the network owner, where the line length P is and what q value has to be used (a value dB/km = q/P) and adjust the microphone amplifier gain regulation accordingly with a feed back resistor between pins 11 and 13. The q value is a gain, the microphone amplifier regulation has to be set to. The receiver gain is fixed. (normally the transmitter and receiver regulation gains are set to the same value, it is only in the case of "soft clipping" the transmitter regulation is bigger)
- 2). The values of R14, 15 and 16 are dependent of telephone station feeding system (2 x AΩ , bat. V), line type (cable

Ω/km) and DC - characteristic of the telephone set (see fig. 14). Therefore calculate or measure the voltage at pin +C at 0 and P km. (the DC - characteristic ought to have been set at this stage) The voltage drop a) in the graph is across the discrete components like the polarity guard bridge, protection components and series transistor for LD - dialling. The voltage drop b) is across R19 or in case of complex line impedance the drop across the network. (I_{pin+C} + eventual additional current taken from pin +C) x R19. Condition: The network with R14, 15, and 16 should not be too low ohmic because it would load the +C unnecessary, increasing the DC mask. (<100μA) The network should not be too high ohmic either thus influencing the precision of the current into the GR input. (≈20μA) The GR input current <1μA.

- 3). Set the gains for transmitter and receiver.

$$V_{GR} = \frac{\frac{DC1}{R_{14}} + \frac{+C}{R_{16}}}{\frac{1}{R_{14}} + \frac{1}{R_{15}} + \frac{1}{R_{16}}}$$

$$\text{at } 0 \text{ km} : 1.237 = \frac{\approx 2}{R_{14}} + \frac{+C_{0km}}{R_{16}}}{\frac{1}{R_{14}} + \frac{1}{R_{15}} + \frac{1}{R_{16}}}$$

$$\text{at } P \text{ km} : 1.085 = \frac{\approx 2}{R_{14}} + \frac{+C_{Pkm}}{R_{16}}}{\frac{1}{R_{14}} + \frac{1}{R_{15}} + \frac{1}{R_{16}}}$$

To calculate R14 and R16 for ex. choose R15 = 18k.

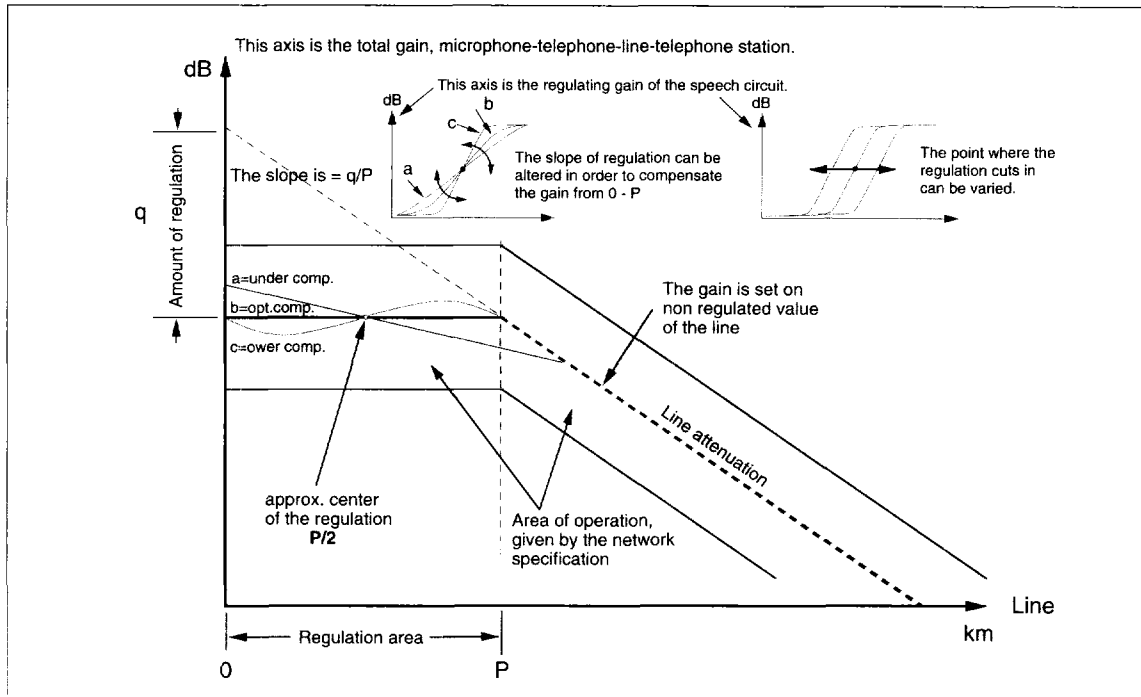

Figure 13. Line length regulation.

In case no regulation is desired the gain can be locked either into low or high gain mode. For high gain mode remove resistors R14 and R16. For low gain mode remove resistors R14 and R15.

It is possible to combine dynamic limiting and line length regulation in the same design as shown in fig. 32. In case no regulation but high gain is required, the pin GR is connected to ground via a

resistor and if low gain is required it is connected via a resistor to a level that is higher than the internal reference of 1.16V. In both cases the current through the resistor should be $\approx 20 \mu\text{A}$ in order to ensure a good precision.

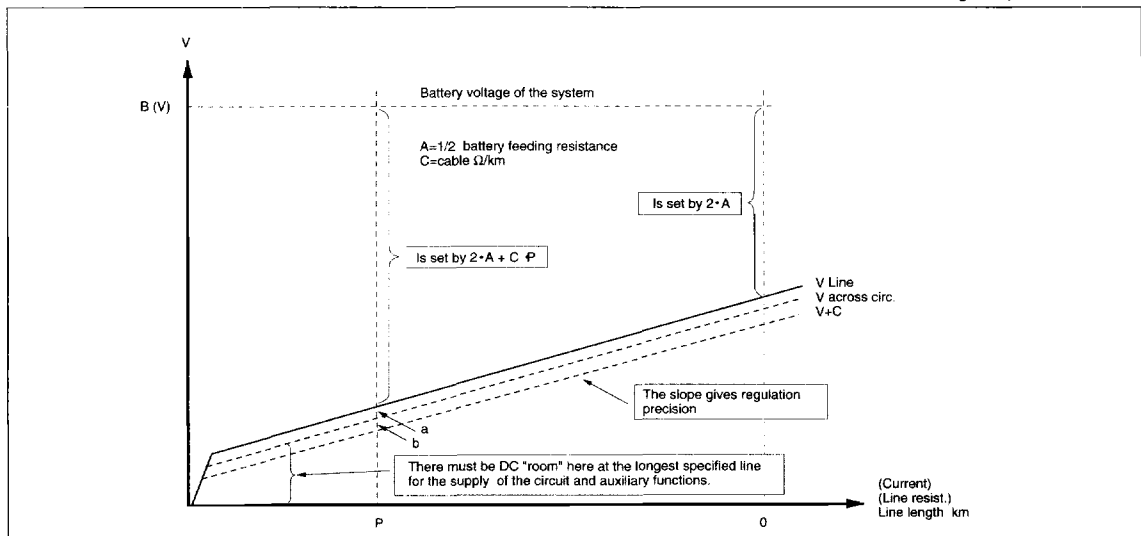

Figure 14. The DC-characteristic of a telephone.

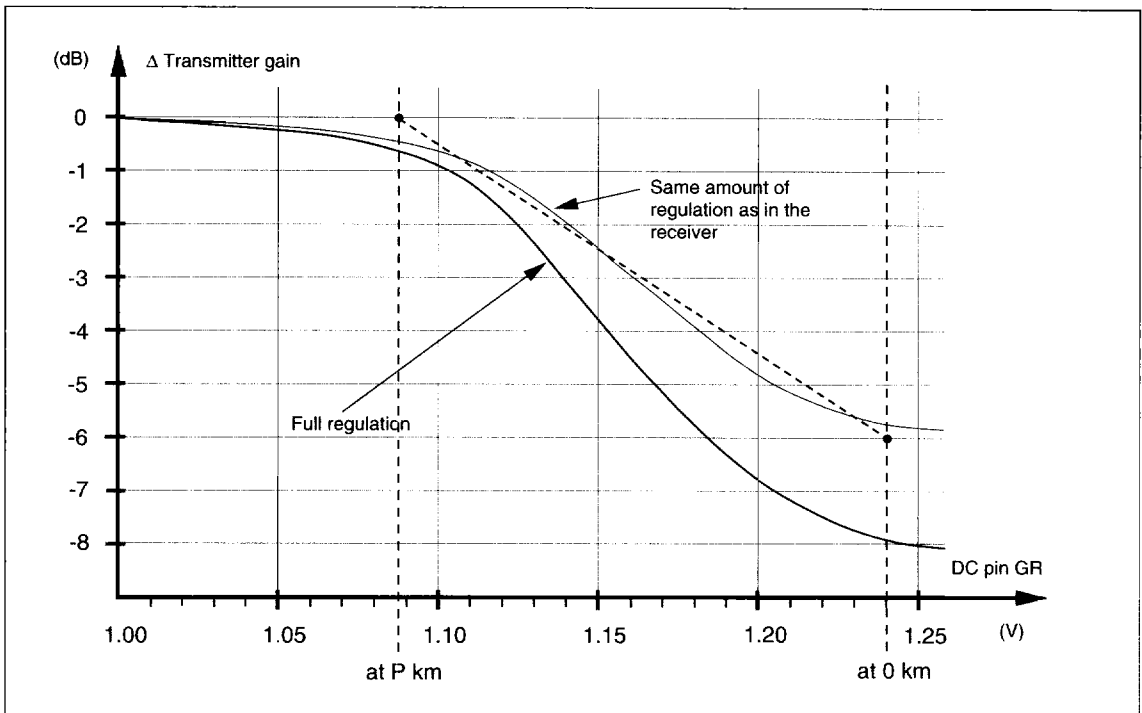

Figure 15. Transmitter line length regulation. How to determine the voltage at pin GR for a certain line length 0-P at a certain regulation of gain.

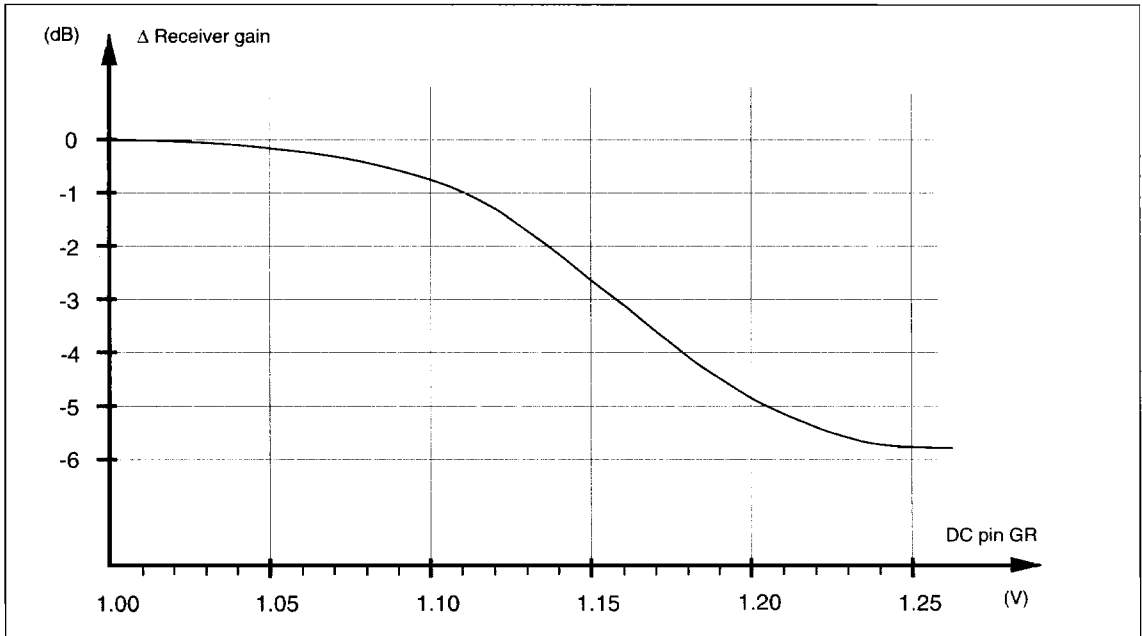

Figure 16. Receiver line length regulation.

Dynamic limiter

The dynamic limiter consists of a full wave rectifier that senses the signal amplitude on the line and produces a control signal that reduces the gain of the transmitter and the receiver when the signal on the line reaches a certain set level. The reason to this is to reduce distortion at high signal levels (See fig. 15, 16, 17, 18 and 34).

The attack point for the dynamic limiter is set by the voltage divider R8, R10 and the internal resistor of 30k (peak signal) the lower frequency limit is set by the input capacitor C5 to pin 7 (RTC). The diodes Da and Db that make the function logarithmic have a 0.6V voltage drop on this signal which is then added to the reference ≈0.855V. The signal will be further rectified with a ratio 1:1, attenuated (can be neglected) in the filter at pin GR and forwarded to the gain regulation.

At a enough high signal in, the voltage at pin GR is set by:

$$V_{pinGR} \approx V_{2peak} \cdot \frac{R_8 // 30k}{R_{10} + R_8 // 30k} - 0.6 + 0.855$$

The time constant "up" is set by the internal ≈ 2.2k and C7, where the time constant "down" is R14 parallel with R15 and C7. The DC-voltage at pin GR with no input signal is set by the resistor divider R14 and R15 at a level just below where regulation starts see fig. 16. It is possible by adjusting this DC-level down to make the time constant "up" longer. With no AC signal in, or a very small and no resistors R14,R15 the rectifier output is at reference in level (0.855V). At no AC signal in the voltage at pin GR is set up by:

$$V_{pinGR} = V_{DC1} \cdot \frac{R_{15}}{R_{14} + R_{15}}$$

If gain regulation with line length is used together with softclipping the time constant "down" will be influenced by the parallel value of R14,R15, and R16. The DC-level at pin GR without AC signal will be set by these three resistors.

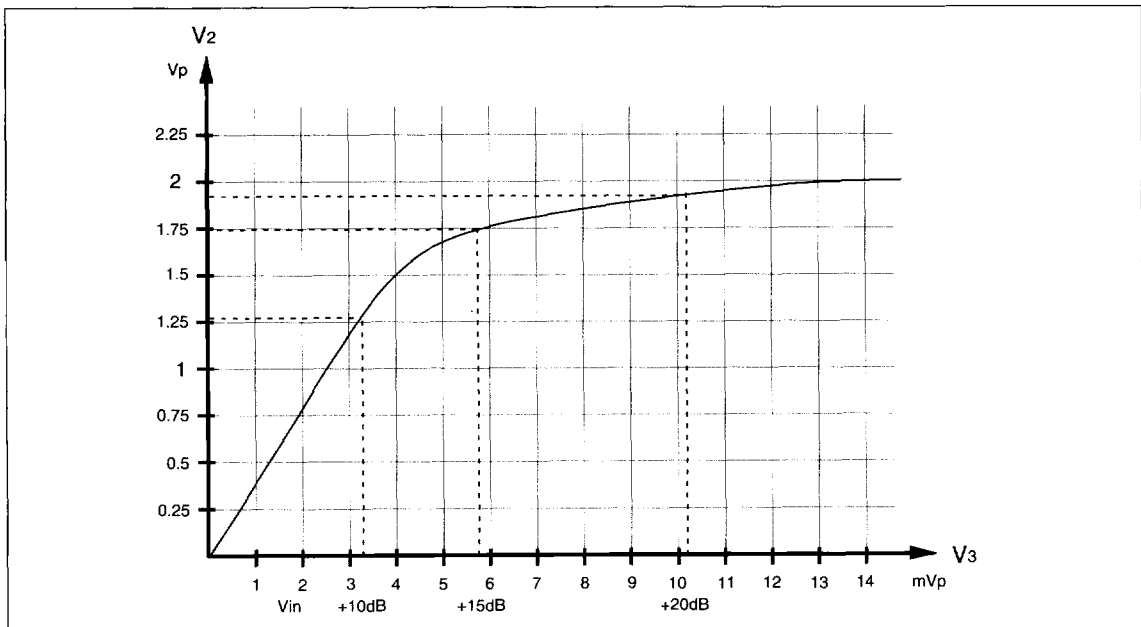

Figure 17. Dynamic limiter.

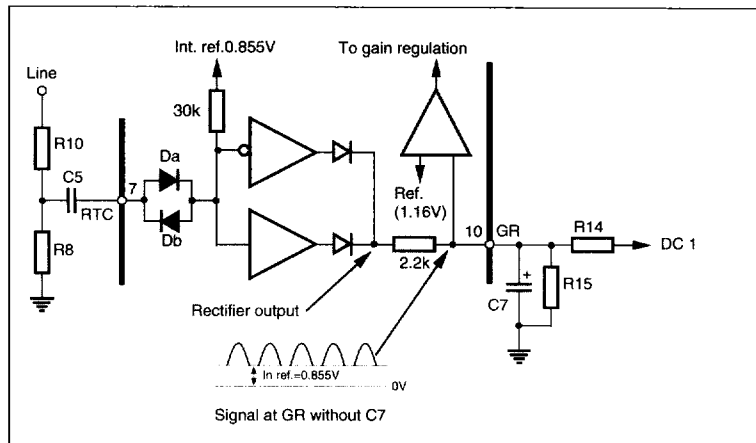

Figure 18. The dynamic limiter function

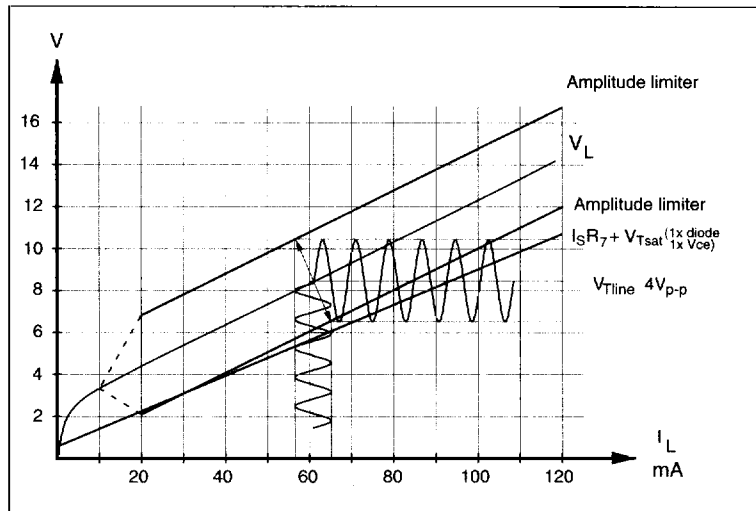

Figure 19. Transmitter output signal limiter. See fig. 22 for data.

Power down and input \overline{PD}

During pulse dialling or register recall (time controlled line break) the telephone line is interrupted, hence the transmission and peripheral circuits are not supplied during the breaks from the line. The circuit has therefore an internal power-down function that automatically shuts down the current consuming parts when the line voltage drops under a certain level. This function reduces the internal current consumption I+C to $\approx 120\mu A$ that in its turn minimizes the charge up time of the capacitor C9 when the line feed returns. The timing and pulse shape at LD - dialling is improved. In some cases the parameters around LD -

dialling can be improved by switching the voltage at this input. Most of the modern processors used for LD-dialling do also supply a "window" signal for the duration of the LD-digit stream. This signal can be used for the \overline{PD} input. An improvement of receiver and transmitter output swing at very low line currents ($I_L < 10mA$) can be achieved by controlling this \overline{PD} input with two resistors and a diode, maybe a capacitor C1 is necessary, see fig. 21. The circuit can be made to work down at 1.8V line voltage and 2.8mA line current. Great care has to be taken to secure against a possible latchup. The \overline{PD} input should not be held "down" at hook-on or at start to hook-off this

restricting the internal reference voltage build up and the circuit to "wake up". (It is good practice to isolate the input with a diode according to fig. 21, an open collector drain can also be used). If the adjusting feature with the two resistors is used, it does not endanger the "waking up" process because the line voltage via R19 will lift the level at \overline{PD} input over the critical reference voltage level of 1.16V. In case this input is not used it should be left "open".

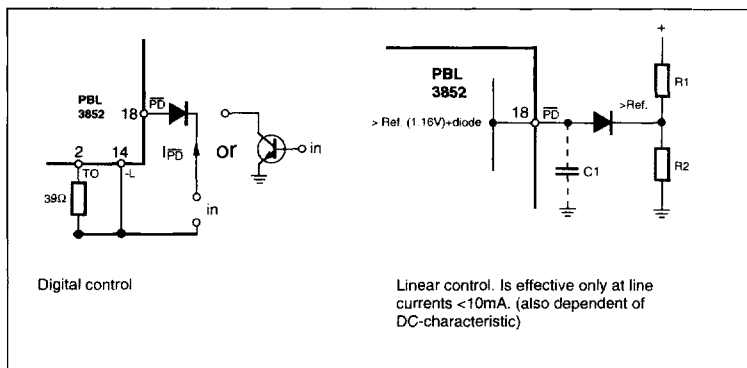

Figure 20. Power down input.

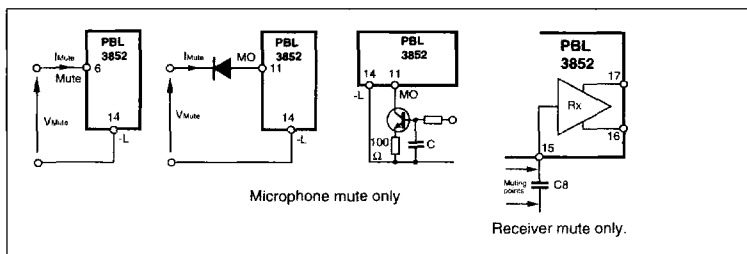

Figure 21. Mute input.

Mute function

The circuit has a mute function at pin 6. By sourcing current into this pin will cut off the gain in the microphone amplifier (attenuation min. 60dB) and decrease the gain in the receiver amplifier to reach the confidence tone level at DTMF-dialling. The receiver mute is \approx -40dB down from the unmuted value to satisfy those who keep the handset close to the ear at dialling. For users who keep the handset from the ear the confidence tone level is too low. To alter the level, a signal can be taken from DTMF generator output to receiver input before the capacitor C8. The added impedance to this point will hardly disturb the signal condition in active speech mode. The microphone amplifier only, can be muted by draining current from the output pin MO. See fig. 21. In case it is required to mute the receiver only, it can be done by shorting the receiver input to ground before or after the input capacitor. Shorting the input pin to ground (does not have to be absolute ground) actuates a mute by driving the amplifier into saturation thus blocking the signal path and rendering a mute with high attenuation but will cause a DC-level shift at output which in its turn

will cause a "click" in the earphone. This can be softened with a slower mute signal flank. If the second approach, grounding before the input capacitor is chosen, the grounding has to be low ohmic in order to render a high attenuating mute.

DTMF (Dual tone multi - frequency) input

The DTMF signal is added between the microphone and transmitter amplifiers, an input that can be seen as a summing point for signals to be transmitted to the line. See fig. 32. Dialling connected like this will render a confidence tone in the receiver at mute condition.

Start up circuit

The circuit contains a start up device which function is to fast charge the capacitor C9 when the circuit goes into hook-off condition. The fast charge circuit is a thyristor function between pins 1 and 4 that will stop conducting when the current drain at pin 4 is lower than \approx 700 μ A + the internal current consumption. (about 1 mA) This circuit can not retrigger before the voltage level at C9

DC-control DCC input

The circuit has a DC- control input that can **adjust** the DC-characteristic. When a current is sourced into this pin the line voltage will increase for a given line current. This will enable an increased negative swing for both the transmitter and receiver at low line currents. If this function is used together with LD - dialling care must be taken that the DC-level of the pulses is according to the specification. The two adjustment paths shown in the fig. 33 will have following functions: Using R20 will alter the adjustment with changing line current where by using the path with R21 renders a fix adjustment. If the input is not used it can be left open or grounded to pin 14.

Power supplies DC1, DC2, V+C and VPh (see fig. 22)

The PBL 3852 generates its own DC supply V+C dependent of line current with an internal shunt regulator. This regulator senses the line voltage V_L via R19 and line current via R7 in order to set the correct V+C so the circuit can generate the required DC characteristic for a given

line resistance R_{Line} and the line feeding data of the exchange. A decoupling capacitor is needed between pins +C and -L. The V_{+C} supply changes its voltage linearly with the line current. It can be used to feed an electret microphone. Caution must be taken though not to drain too much current out of this output because it will affect the internal quick start circuit by locking itself into active state. (max. permissible current drain $600\mu A$)

Care has to be taken when desiding the resistance value of R19. All resistances that are applied from +Line to ground (-Line) will be in parallel, forming the real impedance towards the line. This will sometimes result in, that the ohmic value of R19 is increased in order to comply to the impedance specification towards the line. The speech circuit sinks $\approx 1mA$ into the pin 4, which means that the working voltage for the speech function +V will decrease with the increasing R19, thus starving in the end the circuit of its working voltage. This dependency is often falsely taken as a sign of that the circuit does not work down to the low line current specified, but in fact it is the working voltage at pin 4 that has become too low. It is obvious that this problem is also connected into what kind of DC-

characteristic is set (see fig. 22).

The circuit has further two temperature and line current compensated DC supplies DC1 and DC2. DC1 is a high precision voltage supply for supplying microphones, opto couplers etc. it is also suitable as a voltage reference. Typical voltage 2.1V down to line voltage of 4.1V, in case the line voltage is lower than 4.1V calculate; actual line voltage minus 1.9V. In order to prevent noise entering the line, a resistor is recommended in series with this output.

DC2 is a voltage clamped current source that is suitable to be used in supplying diallers and micro processors but also parts of circuitry that need supply in hook on condition. The typical voltage is 3.7V down to line voltage of 4.75V If the line voltage is lower than 4.75V calculate; actual line voltage minus 1.25V. The current supply to a memory retention capacitor is easiest isolated with a diode, the capacitor preferably a low voltage drop type, and in hook on condition it has to have charge path from an uninterrupted point on the + line. If a diode is not used for isolation care must be taken that no current can be taken out of the reservoir capacitor at or after "hook-on". It must be secured that the receiver can not get any input signal and that there is a capacitor

in series with the output to isolate a DC load. It is possible to feed an external shunt regulator directly from the DC2 output for lower voltage than the clamp level. The line voltage can for a short period of time go below the voltage at this output without affecting the line characteristics, this because the circuit tries to keep the current taken from the line constant at all times. The receiver has its current supply (pt. a in fig. 22) from the DC2 supply. A series resistor at the output will limit the peak current which is one way to limit the possibility for an acoustic shock at the earphone. The handsfree circuits (PBL 3786, 3786/2 and 3880) speech switching function can be supplied directly from this output.

The fourth DC-supply V_{Ph} has an advantage that it does not influence the circuits DC characteristics even at high current drain. The supply has a floating ground reference and is used to supply the power amplifier of a handsfree telephone. (PBL 3786, 3786/2 and 3880) These circuits have a current controlled charging of the supply capacitor and the control signal is taken across the resistor R7.

In case a monitor amplifier is required where the ground reference is hardly necessary, it can be supplied from V_{Ph} .

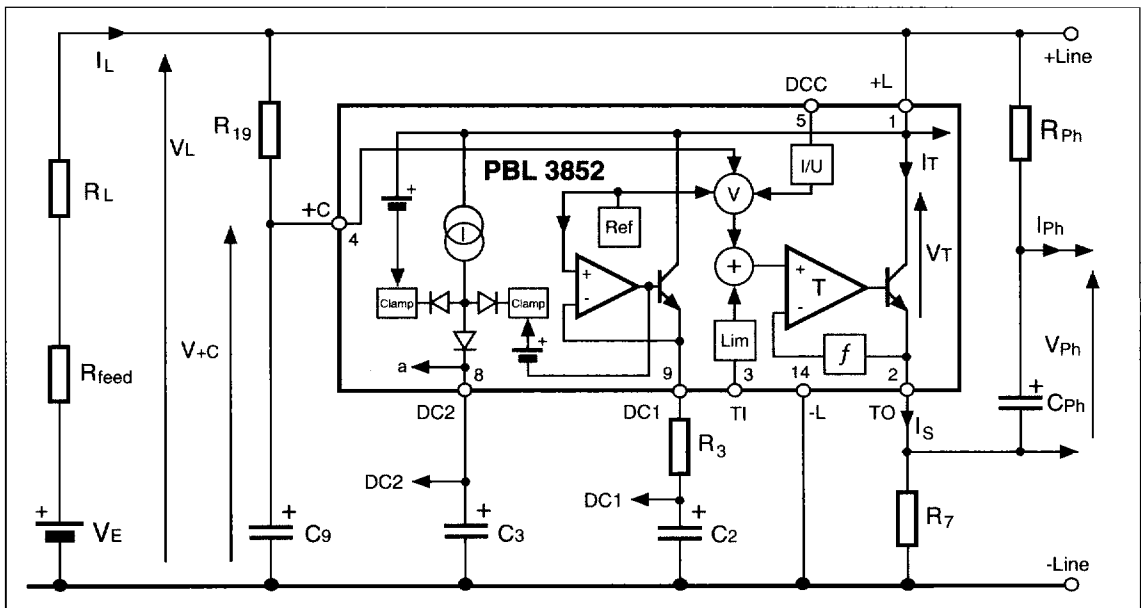

Figure 22. DC-supplies.

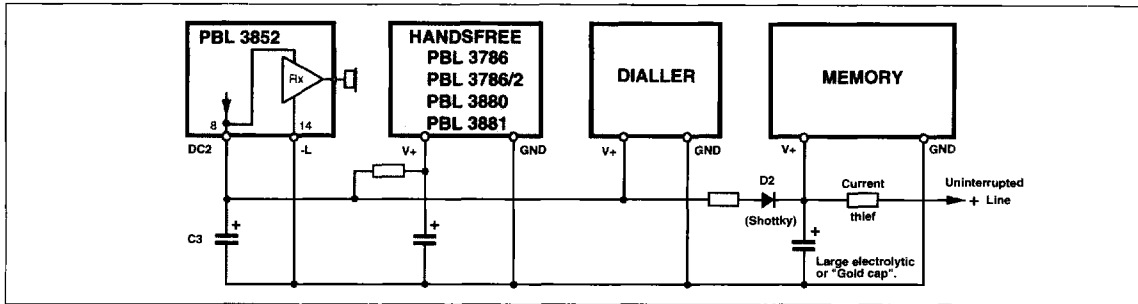

Figure 23. DC-2 supply of peripheral circuits and memory retention.

Side tone suppression (see fig. 24, 26)

The side tone suppression is achieved by adding two signals V+L and VTO in opposite phase at input RI. Because of the complex line impedance Z_{line}, VTO must be compensated by Z_{bal} in order to get the correct level and phase for the signal to be summed. Maximum compensation is achieved when following conditions are fulfilled:

drops below 2V or the line voltage below

$$\frac{R_7}{R_9} = \frac{R_{11}}{R_{18}} Z_{line} // R_{19} \left\{ \frac{1}{R_9} + \frac{1}{R_{11}} + \frac{1}{Z_{bal}} \right\}$$

$$Z_{bal} = \frac{1}{\frac{R_7 R_{18}}{R_9 R_{11}} \frac{1}{Z_{line} // R_{19}} - \frac{1}{R_9} - \frac{1}{R_{11}}}$$

This gives Z_{bal} to be:

$R_{18} \gg Z_{line} // R_{19}$
 $R_9 \gg R_7$
 $Z_{bal} = R_{12}, R_{13} \text{ and } C_6$
 $C_{10} \text{ is omitted in the equation}$

Following should be noted at designing the side tone network:

The impedance of the side tone network in parallel with the R7 should not be too low. This does influence the transmitter gain and frequency response. ($Z_{bal} + R_9 \gg R_7$)

R11 should not be low compared with Z_{bal} this will influence the receiver frequency response. ($R_{11} \gg Z_{bal}$)

The side tone network impedance, parallel with the receiver input impedance Z_{in}, should not be too high compared with Z_{in} this influencing the spread in the receiver gain. ($Z_{in} \gg$ side tone network impedance, $R_{18} // R_{17} // (R_{11} + R_9 // Z_{bal})$)

Maximum compensation without any assumption is obtained when following condition is fulfilled:

$$\frac{R_7}{R_7 + R_9} = R_{11} \frac{Z_{line} // R_{19}}{Z_{line} // R_{19} + R_{18}} \left\{ \frac{1}{R_9} + \frac{1}{R_{11}} + \frac{1}{Z_{bal}} - \frac{R_7 / R_9}{R_7 + R_9} \right\}$$

In practice Z_{line} varies with the line type, length and the feeding system parameters. Therefore Z_{bal} should be chosen to give a satisfactory side tone suppression at an average line length.

An other method is to make R18 complex. See fig.25. This will be advantageous in case the R7 is low ohmic (10-39Ω) because this coupling will give +6 dB more signal for the side tone balancing. Warning! At low values of R7 the circuit will have an insufficient overcurrent protection. A over voltage protection with lower limiting level has to be used across the circuit. It also will make it possible to implement a better working volume control for the earphone. There will be some disadvantages as: More difficult to trim and it needs closer tolerance components.

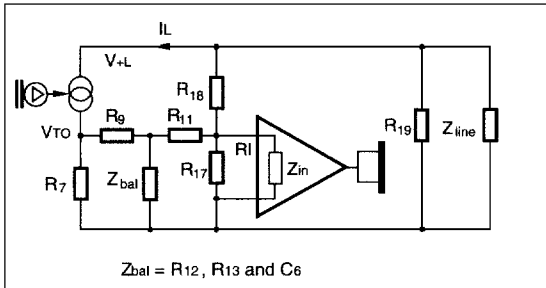

Figure 24. Sidetone balance.

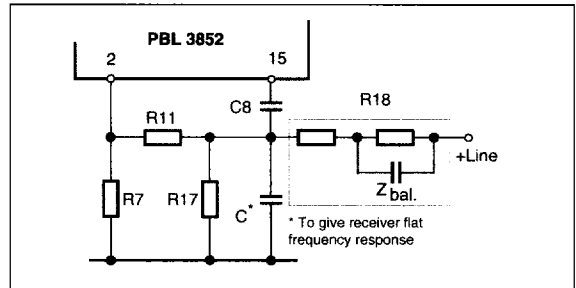

Figure 25. Side tone network with complex R18.

What is balancing the side tone ?

To understand that balancing the side tone is needed to lower the amplitude that reaches ones own ear of the signal that is transmitted from ones own microphone to the line and that enters the receiver quite normally from the line. That in presence of a strong side tone signal one is disturbed by it and instinctively lowers ones voice level, but again if the balance is too good (seldom the case) the earphone will feel "dead". In practical terms, what is expected, is the same amplitude of ones own voice in the ear as without the hand- set. The need to lower the side tone level where no balancing has been done is in the order of one power of ten (20 dB).

To understand the principle both theoretically and practically. See text.

Be sure to understand the balance that is influenced by outer factors like, the impedance of the line and the signal that enters the ear acoustically directly from the mouth through the handset. The signal that enters the microphone from the earphone acoustically will also influence the return loss.

To understand the signal treatment that is at hand. In other words that the side tone network can be trimmed to form a veritable "distortion analyser", so that all the distortion that is present from the microphone even if it is small, will be the only signal entering the earphone. This will sound very bad. It is better to induce some of the fundamental frequency back by making the balance less perfect at that frequency. This is valid for a network that is trimmed to only one frequency. It is to strive to trim the network such that it will at all line combinations attenuate the harmonics the same as the fundamental frequency.

To understand that if one of the two

signals entering the balancing system from either direction, direct from microphone or via the line, is clipped will result in a very distorted signal entering the receiver amplifier and thus the earphone. Further, to remember that side tone is a small signal that is the difference of two large signals and that the distortion can be up to ten times the fundamental frequency.

A short guidance for understanding the side tone principle (see fig. 26)

- Assume the line impedance to be 600Ω.
- Z1 = Line impedance
- Z2 = The telephone set impedance 600Ω
- $Z1//Z2 = 300\Omega$
- R7 will have a certain value 39 - 100Ω to give the telephone a specified DC-characteristic.
- Assuming this DC-characteristic will require $R7 = 60\Omega$ Hence it will be 1/5 of the $Z1//Z2$.
- This will also give 1/5 of the AC-signal that is on the line across R7.
- Note that the signals at points a and b are 180 degrees off phase.
- $10 \times R7 \approx R9 + Zbal$ note #1
- $R9 \approx Zbal$ note #2

The AC-signal at point c is now 1/10 of the signal on the line because it was further divided by two from point b. ($R9=Zbal$).

Hence $10 \times R11 \approx R18$ to satisfy the balancing criteria. R17 is to set the receiver gain. (can be a volume control potentiometer)

Note #1 These values ensure that the frequency behaviour of the transmitter is not influenced. With the ratio 1/10 the influence is 1 dB, and with t ratio 1/20 it's 0.5 dB.

Note #2 If the R9 is made low ohmic compared with Zbal, it will load the latter and result in a bad side tone performance, again if the R9 is made high ohmic compared with Zbal a low signal to balance the side tone will result and make the balancing difficult.

Making any of the impedances unnecessary high will make the circuit sensitive to RFI. All values given here are approximate and serve as starting entities only. The final trimming of side tone network is a cut and try proposition because a part of the balance lies in the acoustical path between the microphone and earphone.

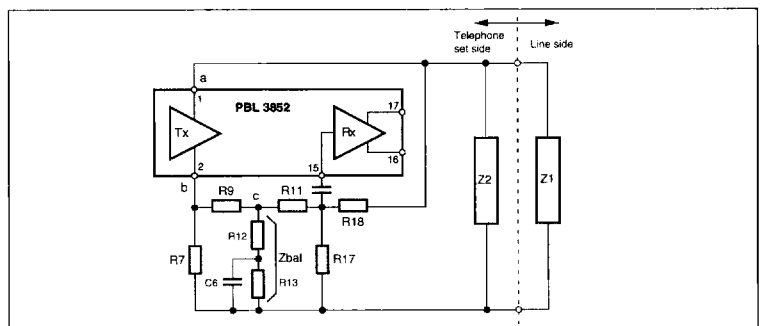

Figure 26. The side tone suppression principle.

Short about Radio Frequency Interference RFI.

HF suppression at the microphone input

The HF-signal at the microphone input can be seen composed as of two components. One component being the differential (between pins 12 and 13) and the second related to ground at pin 14. Of these two, the first is the most serious, entering the amplifier directly being amplified and detected. The second

component is less serious because it affecting both inputs alike and most of it will be balanced out of the amplifier. There might be the case where the HF-signal will have such an amplitude that the amplifier can not balance it out. Then components must be filtered with capacitors and maybe resistors. It is extremely important that everything that is done at the input is in balance, otherways the problem might get worse instead of better. The extreme balance requirement goes all the way to the PCB-layout. Small

unbalance signals can be corrected with capacitors marked with *) this requiring high precision components. See fig 28. The solution shown is rather expensive but with precision components it renders good filtering at the input. If the main problem is the signal between the inputs, try to increase the 1nF capacitor but make the others procentually smaller in order to maintain the frequency response. A more simple solution, that is sufficient in most of the cases is also shown in fig. 27.

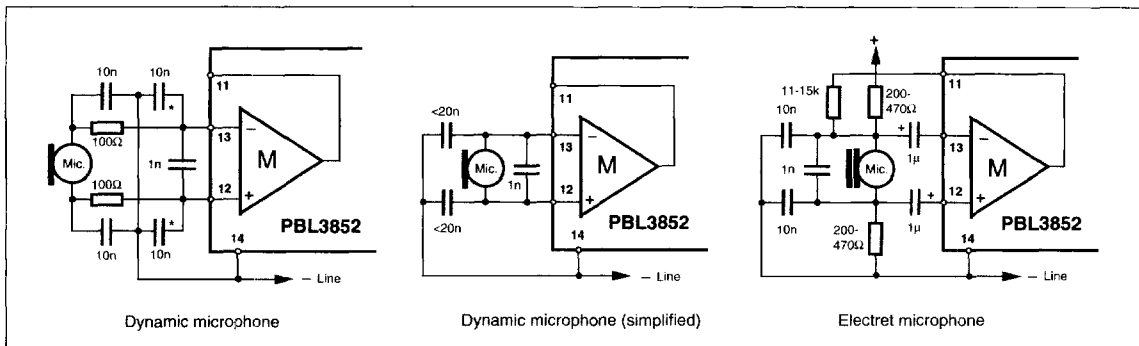

Figure 27. RFI elimination at microphone amplifier input .

HF-suppression at the receiver output

The problem here is of the same kind as at the microphone amplifier input but will be easier to solve because of the much lower impedance and level of gain. The solution is shown in the fig. 28. No capacitors should be connected directly from pins 17 or 18 to ground because of the low output impedance, series resistance of at least 10Ω must be used if there is a tendency to self oscillation.

Other paths for the HF-signal to enter the audible system

To find out if the problem originates in the DTMF-generator disconnect the generator and short the mute input to -line, pin 14. If the problem is small try to connect a capacitor from mute input to -line pin 14. Modern CMOS circuits are more sensitive to RFI because of their high impedance at the input pins, especially the keyboard inputs to the DTMF-generator. These inputs are not possible to filter with large capacitors because of the keyboard scanning pulses (1μs) that will be loaded

down. To shield the keyboard will some times help. The polarity guard bridge can also act as a rectifier and demodulator, of the HF-signals. Connect 1nF capacitors across each diode in the bridge. There is a capacitor across the line C10, this is for RFI suppression but also to stabilise the whole system.

The capacitor C10 should be connected like in figure 30. The frequencies at which the RFI comes through are in the region of 10-1000MHz. The resistance of the C10 will be somewhere 0.01-10Ω hence even the shortest lenght of connector on the PCB board or wire will be in the same region of resistance and thus of greatest of importance. These actions described above should, when applied correctly, take care of the RFI coming in from the telephone line. The second way for the RFI to enter the system is to penetrate the PCB board capacitively. The test methode is to place a metal sheet under the telephone set to be tested and inject the sheet with RF signal. The most

used and effective counter measure to this kind of RFI penetration is to shield the telephone set, at least the bottom of it, that is closest to the main PCB board by metal foil or by spraying the plastic casing with metallic matter. See figure 29. This methode does not necessarily count out the RFI components that are recommended earlier.

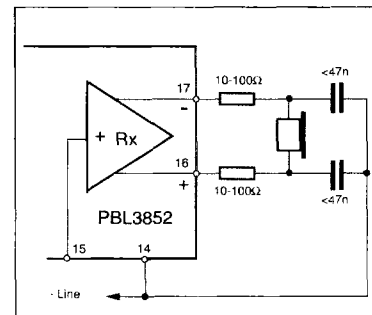

Figure 28. RFI elimination at receiver amplifier output.

Radio interference originating from mobile phones

The problem with direct radiated RFI has accentuated lately because of the growing numbers of mobile and especially pocket telephones. Thus it is today rather common that a RF transmitter with output power of several watts in form of a mobile telephone is placed quite close to an analog telephone. There is a simultaneous even bigger problem coming from these portable phones of digital time-multiplex type like the GSM. The GSM signal consists of 900 MHz carrier that is transmitted in short signal bursts 1/8 of time and with a repetition frequency of slightly higher than 200 Hz. This signal will be directly radiated to all parts in a conventional telephone set. All unlinear elements as most of the semiconductors will envelope detect this signal and thus feed the 200 Hz signal with harmonics into all points of the telephone. The methode to counteract this problem is the same as before with a difference that it has to be done with much more precision. The principle is to attenuate the HF signal to a level where the detected 200 Hz signal is below a disturbing level especially at high sensitive points like at the microphone input.

Following aspects ought to be thought of:

- 1). Do not make any points in the circuitry more high impede than necessary.
- 2). Keep all cables, wires and tracks on PC-board as short as possible.
- 3). Decouple all sensitive points to an internal ground with capacitors especially the microphone amplifier input.
- 4). To include series elements like resistors and inductors in all long wires or cables that could act as aerials. For ex. microphone cable, earphone cable, cable to the telephone network, mute wire and cable to the keypad.
- 5). Comprehend that it is a question of a HF- design, so that all used decoupling components are well suited to the frequencies at hand. (up to several GHz).
- 6). HF- design includes also that tracks on the PC-board act as inductors and therefore it is the more important that the decoupling

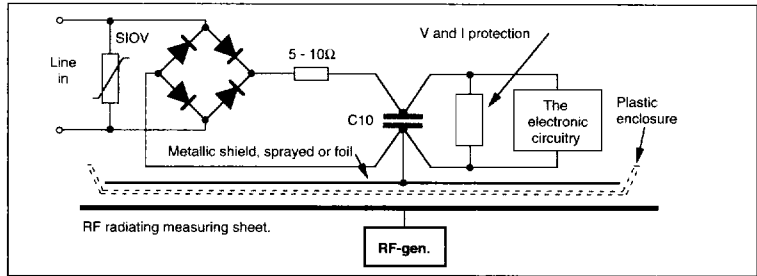

Figure 29. Measuring RFI.

- 7). Balanced points like a differential microphone input may have to be decoupled differentially between the inputs and "common mode" to common ground each input separately.
- 8). A virtual ground may have to be created into which all outgoing cables are decoupled in order to bypass the RF- signal. See fig. 31.
- 9). Think that even overvoltage and overcurrent protectors can be acting as HF detectors.
- 10). Shields that are connected to the internal ground can be of help.
- 11). Control that no already detected signals from for ex. dialler enter the speech circuit via the mute function.

- 12). Try to reach a high packing density on the PC-board.
- 13). Connect components as close to the IC as possible. Connect especially decoupling capacitors close to the ground pin of the IC.

The terminal circuits from Ericsson Components are manufactured in IC processes with large internal capacitors on the chip to counteract RFI disturbances in every possible way. The simplest method to test the susceptibility of an apparatus to RFI is to take a portable phone of an actual type and move it transmitting across the phone, cables and handset. Measure the signal at earphone output as well as on the line. Finally; to design an ordinary analog telephone is not a low frequency but a high frequency task.

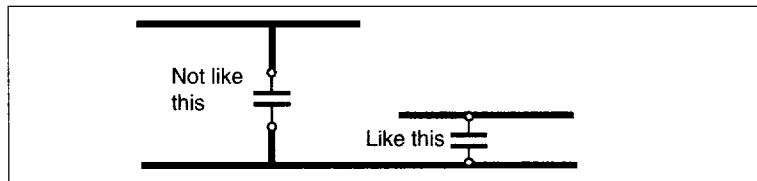

Figure 30. RFI elimination at PCB layout level.

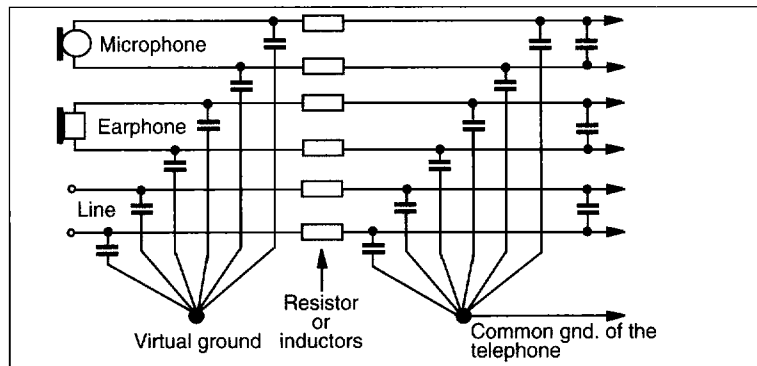
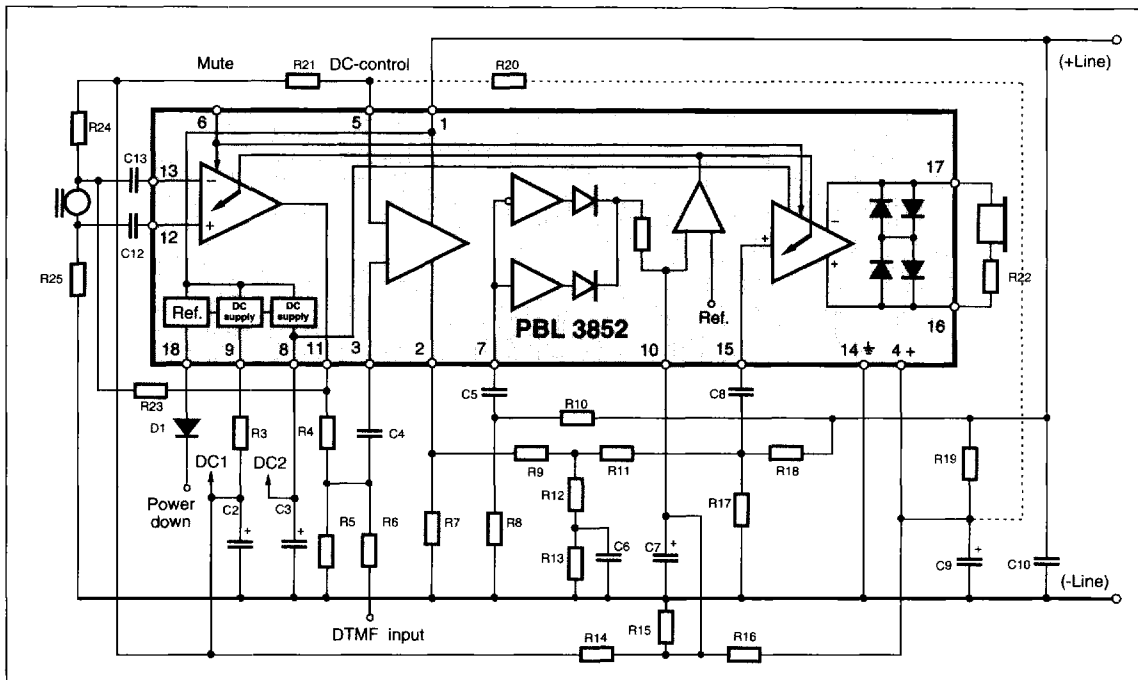

Figure 31. RFI elimination in the wiring.



Component list for application with standard line length regulation, 2x400Ω line feed and soft clipping.

- | | |
|----------------------|------------|
| R1 = - | C1 = - |
| R2 = - | C2 = 47μF |
| R3 = 100Ω | C3 = 47μF |
| R4 = 9.1k | C4 = 150nF |
| R5 = 33k | C5 = 47nF |
| R6 = DTMF level adj. | C6 = 100nF |
| R7 = 75Ω | C7 = 2.2μF |
| R8 = 6.8k | C8 = 47nF |
| R9 = 620Ω | C9 = 47μF |
| R10 = 6.2k | C10 = 15nF |
| R11 = 6.2k | C11 = - |
| R12 = 130Ω | C12 = 1μF |
| R13 = 2.4k | C13 = 1μF |
| R14 = 470k | |
| R15 = 330k | |
| R16 = 2.4M | |
| R17 = 13k | |
| R18 = 62k | |
| R19 = 910Ω | |
| R20 = - | |
| R21 = - | |
| R22 = 150Ω | |
| R23 = 17k | |
| R24 = 200Ω | |
| R25 = 200Ω | |

Without softclipping: Remove following components C5, C7, R8 and R10
 Sweden: Alter following values R14 = 33k, R15 = 20k, R16 = 90k, R21 = 130k

Figure 32. Application with standard line length regulation, 2x400Ω line feed and soft clipping.

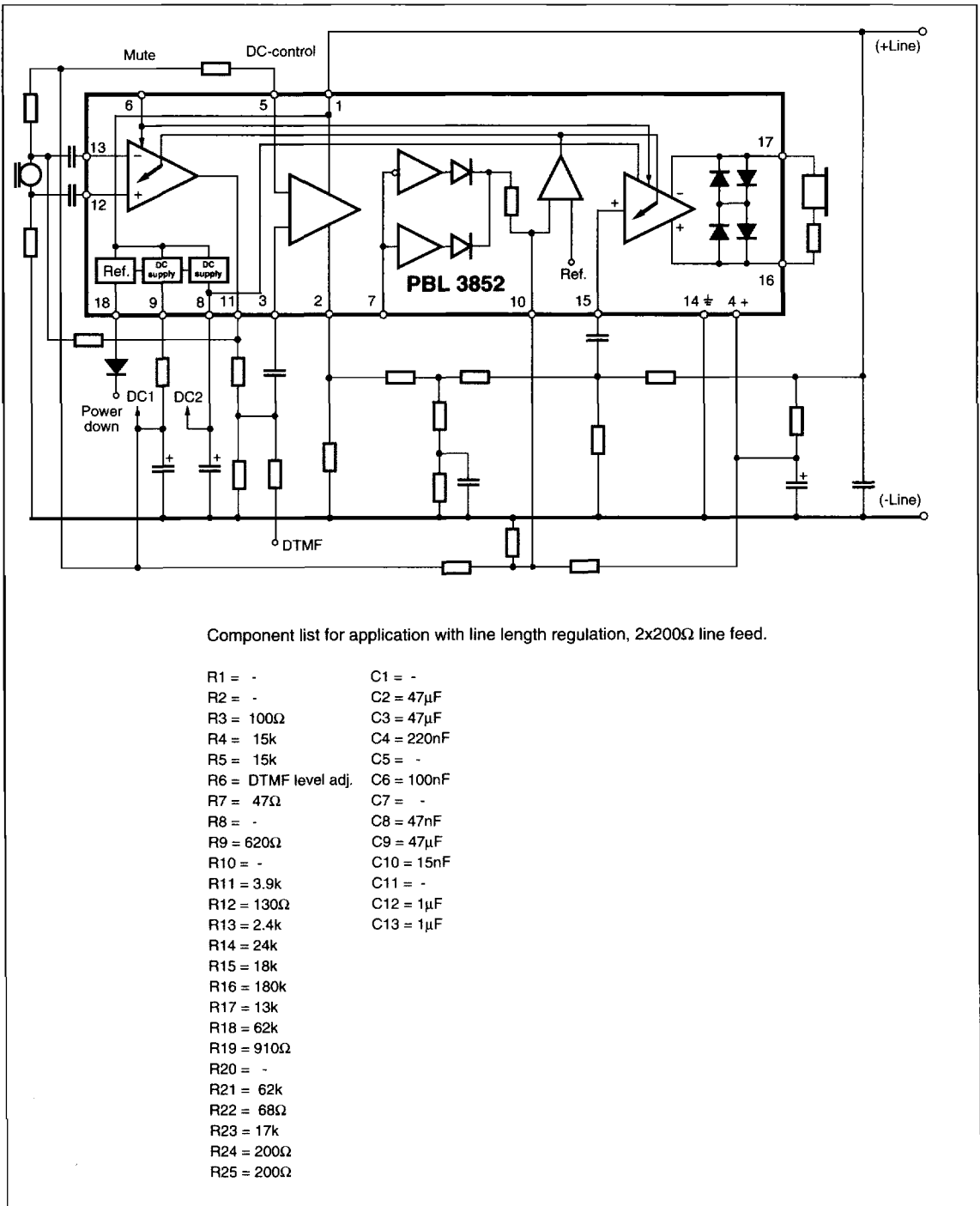
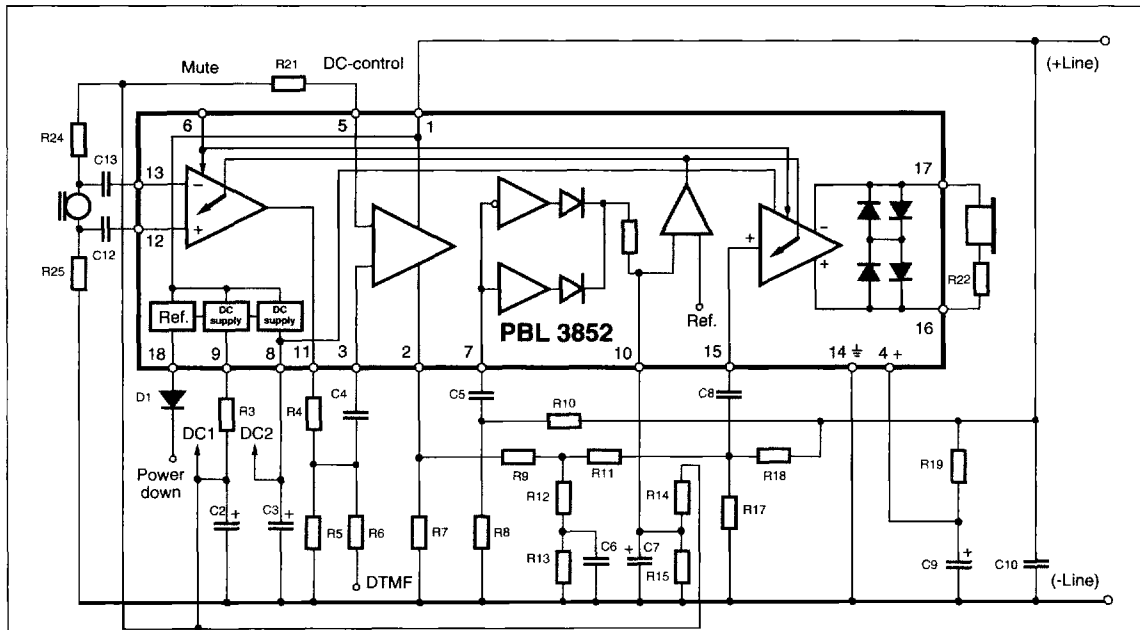

Figure 33. Application with line length regulation, 2x200Ω line feed.



Component list for application with soft clipping.

R1 = -	C1 = -
R2 = -	C2 = 47 μ F
R3 = 100 Ω	C3 = 47 μ F
R4 = 24k	C4 = 150nF
R5 = 10k	C5 = 47nF
R6 = DTMF level adj.	C6 = 100nF
R7 = 39 Ω	C7 = 2.2 μ F
R8 = 30k	C8 = 47nF
R9 = 620 Ω	C9 = 47 μ F
R10 = 24k	C10 = 15nF
R11 = 3.3k	C11 = -
R12 = 130 Ω	C12 = 1 μ F
R13 = 2.4 Ω	C13 = 1 μ F
R14 = 360k	
R15 = 360k	
R16 = -	
R17 = 13k	
R18 = 62k	
R19 = 910 Ω	
R20 = -	
R21 = 15k	
R22 = 30 Ω	
R23 = -	
R24 = 200 Ω	
R25 = 200 Ω	

Figure 34. Application with softclipping.

Information given in this data sheet is believed to be accurate and reliable. However no responsibility is assumed for the consequences of its use nor for any infringement of patents or other rights of third parties which may result from its use. No license is granted by implication or otherwise under any patent or patent rights of Ericsson Components. These products are sold only according to Ericsson Components' general conditions of sale, unless otherwise confirmed in writing.

Specifications subject to change without notice.

IC4 (94020) B-Ue

© Ericsson Components AB 1996



Ericsson Components AB

S-164 81 Kista-Stockholm, Sweden

Telephone: (08) 757 50 00