

HIGH ISOLATION VOLTAGE AC INPUT, DARLINGTON TRANSISTOR TYPE SOP MULTI PHOTOCOUPLER

PS2706-1
PS2706-2
PS2706-4

FEATURES

- **HIGH ISOLATION VOLTAGE**
BV: 3.75 k Vr.m.s. MIN
- **SOP (SMALL OUT-LINE PACKAGE)**
- **ISOLATED CHANNELS PER EACH PACKAGE**
- **AC INPUT RESPONSE**
- **HIGH CURRENT TRANSFER RATIO**
CTR = 200% MIN @ $I_F = \pm 1$ mA, $V_{CE} = 2$ V
- **HIGH SPEED SWITCHING**
 $t_r, t_f = 200$ μ s TYP
- **TAPING PRODUCT NUMBER (ONLY -1 TYPE)**
PS2706-1-E3, F3
- **UL RECOGNIZED**

DESCRIPTION

The PS2706-1,-2 and -4 series are optically coupled isolators containing a GaAs light emitting diode and an NPN silicon Darlington-connected phototransistor. Each is mounted in a plastic SOP (Small Out-Line Package) for high density applications. This package has a shield effect to cut off ambient light.

APPLICATIONS

Interface circuit for various instrumentations and control equipment.

- **AC LINE/DIGITAL LOGIC**
- **DIGITAL LOGIC INTERFACE**
- **TWISTED PAIR LINE RECEIVER**
- **TELEPHONE/TELEGRAPH LINE RECEIVER**
- **SEQUENCE CONTROLLERS**
- **SYSTEMS APPLICATIONS, MEASURING INSTRUMENTS**

1

ELECTRICAL CHARACTERISTICS ($T_A = 25^\circ\text{C}$)

PART NUMBER			PS2706-1, -2, -4		
SYMBOLS	PARAMETERS	UNITS	MIN	TYP	MAX
Diode	V_F	Forward Voltage, $I_F = \pm 5$ mA	V	1.1	1.4
	C	Junction Capacitance, $V = 0$, $f = 1.0$ MHz	pF	60	
Transistor	I_{CEO}	Collector to Emitter Dark Current, $V_{CE} = 40$ V, $I_F = 0$	nA		400
Coupled	CTR	Current Transfer Ratio, $I_F = \pm 1$ mA, $V_{CE} = 2$ V	%	200	2000
	CTR1/CTR2	CTR Ratio ¹ , $I_F = \pm 1$ mA, $V_{CE} = 2$ V		0.3	1.0
	$V_{CE(sat)}$	Collector Saturation Voltage, $I_F = \pm 1$ mA, $I_C = 2$ mA	V		1.0
	R1-2	Isolation Resistance, $V_{in-out} = 1.0$ k V	Ω	10^{11}	
	C1-2	Isolation Capacitance, $V = 0$, $f = 1.0$ MHz	pF	0.4	
	t_r	Rise Time ² , $V_{CC} = 5$ V, $I_C = 2$ mA, $R_L = 100$ Ω	μ s		200
t_f	Fall Time ² , $V_{CC} = 5$ V, $I_C = 2$ mA, $R_L = 100$ Ω	μ s		200	

1. $CTR_1 = \frac{I_{C1}}{I_{F1}}$ $CTR_2 = \frac{I_{C2}}{I_{F2}}$

2. Test Circuit for Switching Time

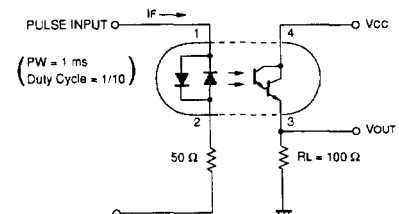
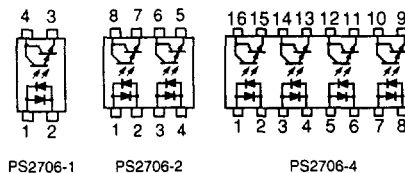
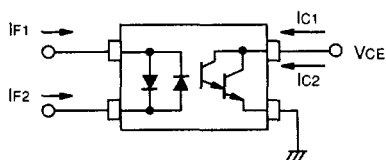

PS2706-1, PS2706-2, PS2706-4

ABSOLUTE MAXIMUM RATINGS¹ (T_A = 25°C)

SYMBOLS	PARAMETERS	UNITS	RATINGS	
Diode			PS2706-1	PS2706-2,-4
I _F	Forward Current (DC)	mA	±50	±50
P _D	Power Dissipation	mW/Ch	80	80
I _{F(Peak)}	Peak Forward Current PW = 100 μs, Duty Cycle 1%	A	±1	±1
Transistor				
V _{CEO}	Collector to Emitter Voltage (I _C = 1mA, I _B = 0)	V	40	40
V _{ECO}	Emitter to Collector Voltage (I _E = 100μA, I _B = 0)	V	6	6
I _C	Collector Current	mA/Ch	200	160
P _C	Power Dissipation	mW/Ch	150	120
Coupled				
BV	Isolation Voltage ²	V _{r.m.s.}	3750	3750
T _{STG}	Storage Temperature	°C	-55 to +150	-55 to +150
T _{OP}	Operating Temperature	°C	-50 to +100	-55 to +100

Notes:

1. Operation in excess of any one of these parameters may result in permanent damage.
2. AC voltage for 1 minute at T_A = 25 °C, RH = 60 % between input and output.

TYPICAL PERFORMANCE CURVES (T_A = 25 °C)

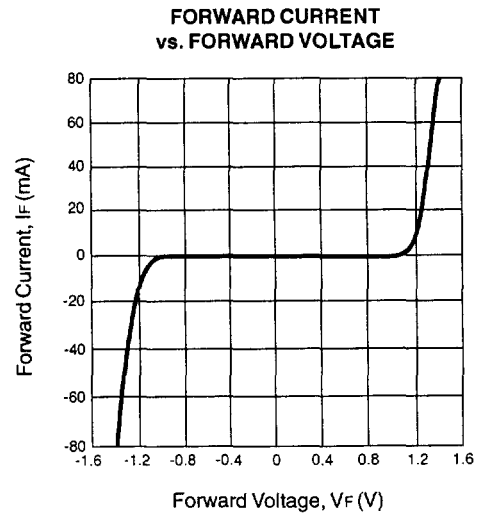
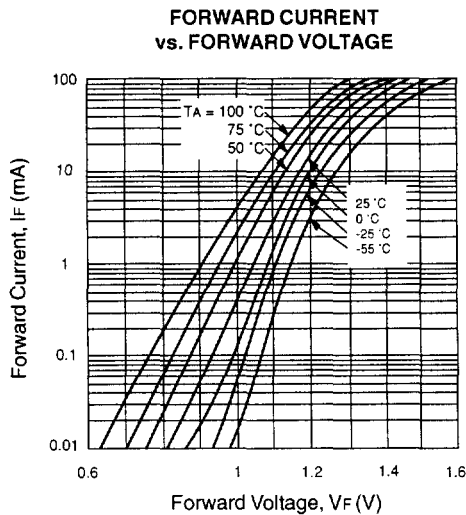
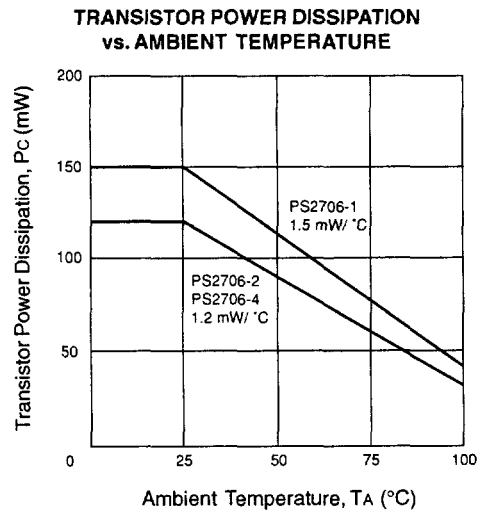
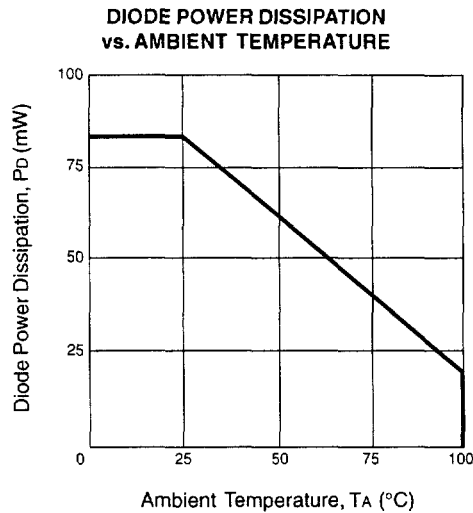

TYPICAL PERFORMANCE CURVES ($T_A = 25^\circ\text{C}$)

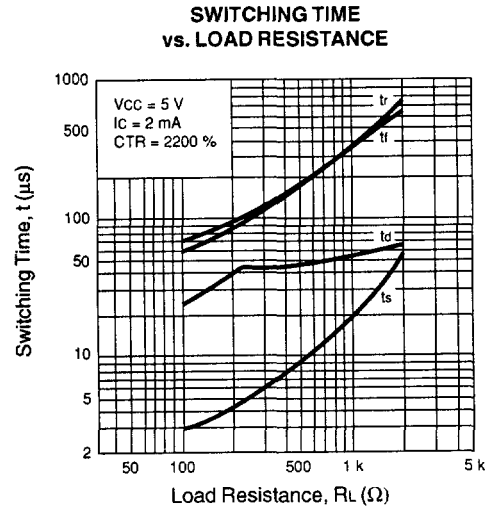
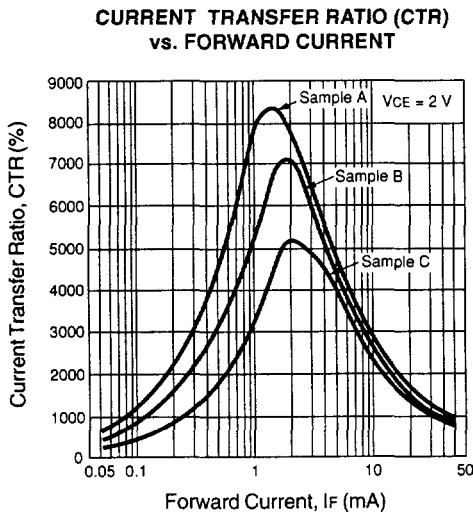
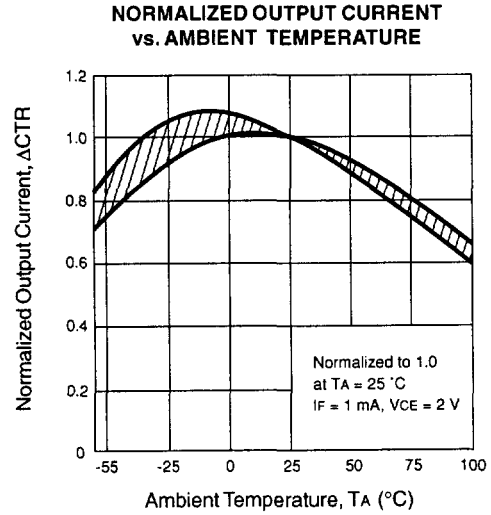
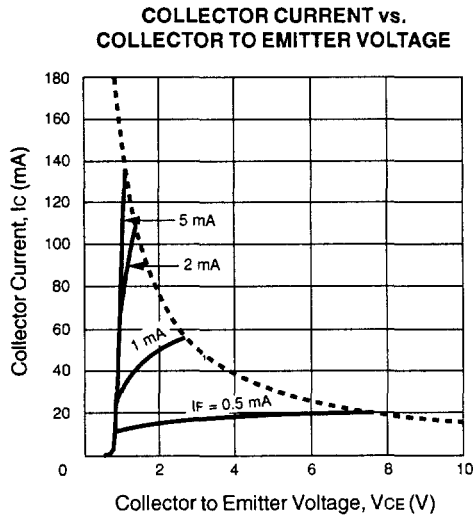
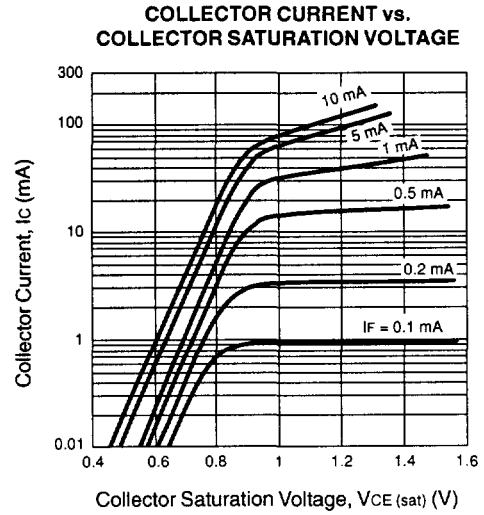
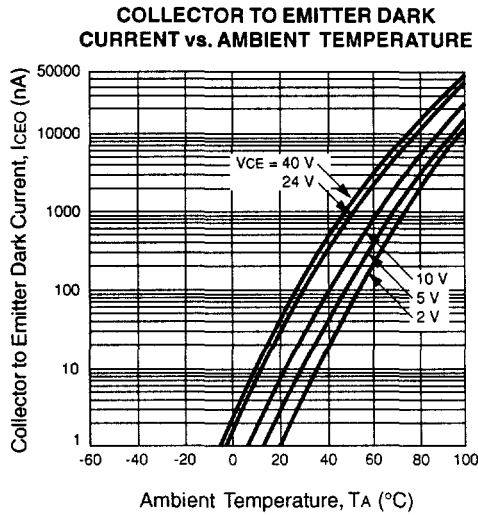

TYPICAL PERFORMANCE CURVES ($T_A = 25^\circ\text{C}$)

FREQUENCY RESPONSE

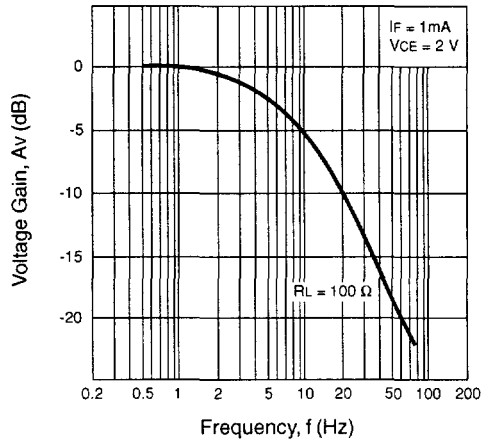

SWITCHING TIME vs. LOAD RESISTANCE

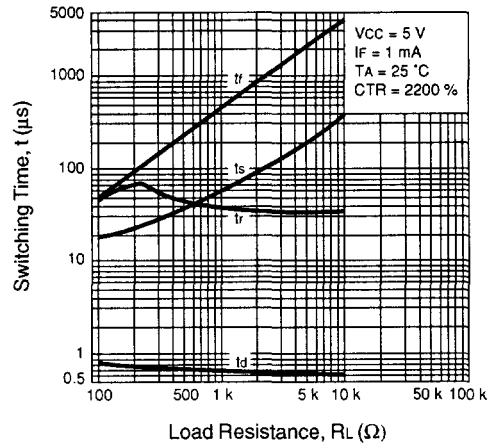

CTR DEGRADATION

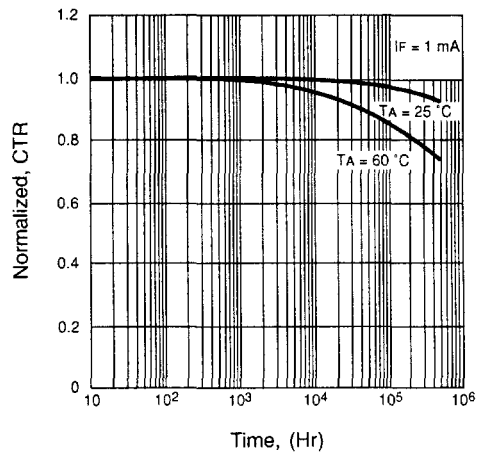

OUTLINE DIMENSIONS (Units in mm)

PS2706-1

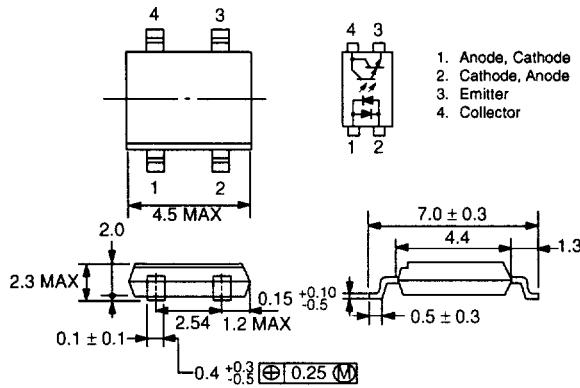

PS2706-2

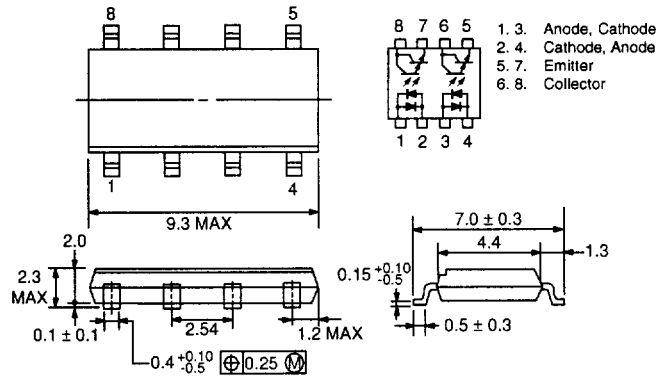

PS2706-4

